



fiatusa.com/abarth
1-888-ciao-fiat



(1) No system, no matter how sophisticated, can repeal the laws of physics or overcome careless driving actions. Performance is limited by available traction, which snow, ice, and other conditions can affect. When the ESC warning lamp flashes, the driver needs to use less throttle and adapt speed and driving behavior to prevailing road conditions. Always drive carefully, consistent with conditions. Always wear your seat belt. (2) Always use BLUEMIE® in a safe manner, with eyes on the road and hands on the wheel at all times. (3) Consult local ordinances on affixing TomTom navigation in appropriate location. (4) The advanced front air bags in this vehicle are certified to the new U.S. federal regulations for advanced air bags. Children 12 years old and younger should always ride buckled up in a rear seat. Infants in rear-facing child restraints should never ride in the front seat of a vehicle with a passenger front air bag. All occupants should always wear their lap and shoulder belts properly. (5) SiriusXM service requires a subscription, sold separately, after 12-month trial included with vehicle purchase. If you decide to continue your SiriusXM service at the end of your trial subscription, the plan you choose will automatically renew and bill at then-current rates until you call SiriusXM at 1-866-635-2349 to cancel. See our Customer Agreement for complete terms at siriusxm.com. Programming subject to change. Sirius satellite service is available only to those at least 18 and older in the 48 contiguous U.S.A., D.C., and PR (with coverage limitations). SiriusXM Traffic available in select markets. See siriusxm.com/traffic for more information. Sirius, XM, and all related marks and logos are trademarks of SiriusXM Radio Inc.

This brochure is a publication of Chrysler Group LLC. All product illustrations and specifications are based upon current information at the time of publication approval. Chrysler Group LLC reserves the right to make changes from time to time, without notice or obligation, in price, specifications, colors, materials, and to change or discontinue models, which are considered necessary to the purpose of product improvement or for reasons of design and/or marketing. ©2012 Chrysler Group LLC. All rights reserved. Chrysler and Mopar are registered trademarks of Chrysler Group LLC. FIAT and BLUEMIE are registered trademarks of FIAT Group Marketing & Corporate Communication S.p.A., used under license by Chrysler Group LLC. Abarth and the Scorpion design are registered trademarks of FIAT Auto S.p.A., used under license by Chrysler Group LLC. Alfa Romeo is a registered trademark of FIAT Auto S.p.A. Alpine and the Alpine logo are registered trademarks of Alpine Electronics, Inc. All rights reserved. The trademarks by Dr. Dre, Beats, Beats Audio, and the b logo are property of Beats Electronics, LLC. Bluetooth is a registered trademark of Bluetooth SIG, Inc. Facebook is a registered trademark of Facebook, Inc. Garmin, navi, and the Garmin logo are registered trademarks of Garmin, Ltd. or its subsidiaries and are registered in one or more countries, including the U.S. iPad, iPhone, iPod, and iTunes are registered trademarks of Apple Inc. KONI is a registered trademark of KONI North America. MultiAir is a registered trademark of C.R.F., used under license by Chrysler Group LLC. Pirelli is a registered trademark of Pirelli & C. S.p.A. Sirius, XM, and all related marks and logos are trademarks of SiriusXM Radio Inc. TomTom is a registered trademark of TomTom International BV. The Twitter name, logo, Twitter T, Tweet, and Twitter bird are trademarks of Twitter, Inc. in the United States and other countries. YouTube is a registered trademark of Google Inc.







THE ABARTH® COLLECTION

Display your affection for striking style with merchandise that complements an active lifestyle. Choose from a wide selection — from trendy apparel to conversation pieces for home, office, and travel. Visit www.e-store.fiatusa.com.





WARRANTIES

Standard Coverage for FIAT® 500 and FIAT 500 Abarth includes: Basic Limited Warranty — 4 Years/50,000 Miles; Anti-Corrosion Perforation Limited Warranty (Outer Panel) — 12 Years/Unlimited; Roadside Assistance (service includes the following) — 4 Years/Unlimited: flat tire service, out of gas/fuel delivery (max. two gallons), battery jump assistance, lockout service, and towing assistance.

AUTHENTIC CHRYSLER ACCESSORIES BY MOPAR®

Designed specifically for your Chrysler vehicle for exceptional fit, finish, and performance. Visit your dealership or mopar.com.

JOIN IN

    Join fellow enthusiasts and tell your story by posting comments, participating in discussions, and sharing your FIAT vehicle photos and videos. Find our community on Facebook (facebook.com/fiatusa), follow us on Twitter (twitter.com/fiatusa), and check us out on YouTube (youtube.com/fiatusa), Google+ (google.com/+fiatusa) and FIAT Backstage Blog (blog.fiatusa.com). Thank you for following.

GO MOBILE

 Take an engaging, multimedia tour of your vehicle on your mobile device. Visit the Chrysler Group LLC page on iTunes® from your smartphone or iPad® to download the most up-to-date apps on all of the company's vehicles. Log on to the fiatusa.com mobile site for a comprehensive, at-a-glance reference for everything you need to know about your FIAT vehicle. Experience visual and interactive demonstrations of the entire lineup, and keep access to product information at your fingertips, wherever you go.



**IT HITS THESE SHORES WITH AN ATTITUDE
PROPELLED BY A RACING HISTORY
THAT RIVALS THE MOST LEGENDARY
OF MARQUES. IT MAKES PASSIONATE
STATEMENTS STITCHED IN LEATHER
AND PROJECTS DETAILS TAILORED
STRAIGHT TO THE HEART OF PURE
PERFORMANCE. ON RACETRACKS. ON
HIGHWAYS. AND NOW, ON CONTINENTS.
CODED FROM A VISION, IT LANDS WITH
EVERYTHING THAT THE ABARTH® BADGE
HAS COME TO REPRESENT. BEHOLD THE
SCORPION. THIS IS THE FIAT® 500 ABARTH.**





The man behind the name: Karl Abarth. Born in Vienna, Austria, in 1908, he wasted little time in making a name for himself on European racetracks. Atop a motorcycle Abarth built himself, the legend of engineering ingenuity and standout performance was born. He was not yet 30, but the foundation of his legacy had been poured. Exchanging the credit of his wins for citizenship, he became an Italian citizen and focused on automotive design, performance-exhaust engineering, and stock car building.

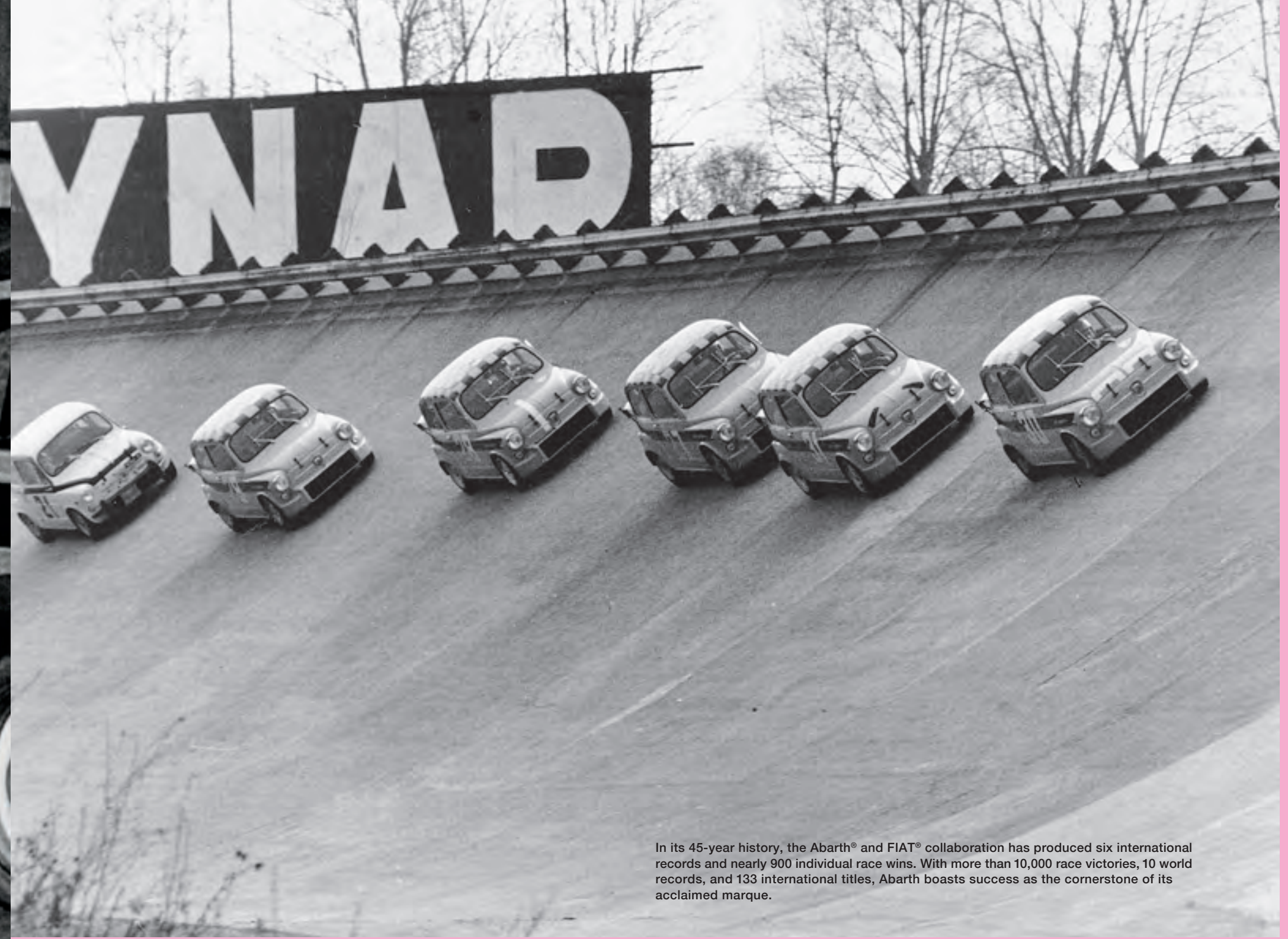

In its 45-year history, the Abarth® and FIAT® collaboration has produced six international records and nearly 900 individual race wins. With more than 10,000 race victories, 10 world records, and 133 international titles, Abarth boasts success as the cornerstone of its acclaimed marque.





ABARTH

ABARTH® HISTORY

THIS IS THE STORY OF THE SCORPION. It sprung from the piercing vision of Karl Abarth almost a century ago: “Go faster than yesterday.” It served as the cornerstone upon which a well-crafted empire of finely tuned performance was built.

+ **2012** As unique and determined as its namesake, the modern FIAT® 500 Abarth packs a powerful sting, as well as refined driving dynamics, enhanced safety and security features, and a luxury-sport interior.

2011 The FIAT 500 Abarth is introduced in the U.S. and North American markets, premiering at the 2011 Los Angeles International Auto Show.

2007 The Fiat Group relaunches Abarth & C. S.p.A. The company's first achievement includes the Grande Punto Abarth S2000, which wins the Intercontinental Rally Challenge.

1980–90 September 30, 1981, Abarth & C. is decreed a union by incorporation within FIAT Auto S.p.A. The brand makes few headlines during this time and is relaunched by FIAT in 2007.

1979 Karl Abarth passes away on October 24. The Abarth name continues into the '80s with the success of the FIAT Strada Abarth 130TC.

1971 Abarth merges with Fiat Auto and success continues in the world championships of the early '70s. This legacy includes 10 world records and over 10,000 track victories.

+ **1965** The Scorpion badge becomes such a symbol of power and performance that it enters everyday language in its native Italy. Rather than a strong coffee, customers instead ask for an “Abarth coffee.”

1965 The '60s are a golden age for the Scorpion, and the FIAT 595 Abarth tallies nearly 900 victories over a seven-year run.

1962 The Abarth 850TC wins the World Championship race at Circuito del Garda.

+ **1958** Karl Abarth creates the FIAT 500 Abarth. At Monza that year, the car covers a distance of 18,186 km at an average speed of 108 km/h, breaking six international records, nearly one every day. That year, Abarth strengthens its partnership with FIAT.

1956 Karl Abarth breaks the 5,000- and 10,000-km, 5,000-mile, and 48- and 72-hour records driving the FIAT Abarth 750.

+ **1956** The success of the exhaust systems and motorsport achievements attracts attention from major manufacturers, as well as the son of a former U.S. president, who traveled to Italy to sign an agreement to distribute Abarth products and vehicles in America.

1955 The FIAT Abarth 750, with a body by Bertone, is presented and immediately sets a number of endurance and speed records. Two different versions of the same car appear with a Zagato body: FIAT Abarth 750 Zagato and FIAT Abarth 750 GT Zagato.

+ **1955** The Abarth 750 GT is launched.

1950 By year-end, Abarth & C. employs more than 40 people and sells more than 4,500 exhaust systems.

1950 The logo emblazoned on every Abarth model is inspired by the astrological sign Karl Abarth is born under — Scorpio. It reflects his feisty and, at times, temperamental manner.

+ **1949** Karl Abarth starts Abarth & C., a company producing aftermarket products for production cars, as well as performance exhaust systems. He wins the Italian 1100 and Formula 2 championships with the first race car he ever builds — the 204 A Roadster, derived from the FIAT 1100.

1946 Abarth is contracted to build his first car, a revolutionary new single-seater named the Cisitalia D46. Two models place first and second in the 1946 Brezzi Cup in Turin.

1930 A serious accident in Linz, Austria, forces Abarth to abandon solo motorcycle racing. However, he continues to race and build motorcycle sidecars until 1939.

+ **1929** Shortly after Karl Abarth gets his start racing motorcycles, he builds the first motorcycle to bear the Abarth name. During his competitive years, he becomes a five-time European Champion.



BREZZI COP CIRCUITO DEL GARDA MILLE MIG
 ELLEGRINO CIRCUITO SENIGALLIA COPPA INTEREUROPA
 TROFEO SARDO GIRO DI CALABRIA RALLYE DELLA VALTE
 OMA COURSE DE COTE GIRO DI SICILIA TROFEO LUMEZ
 ENEVE AUTOSLALOM RALLYE DEL SALENTO ENDENWAL
 EL BUSENTO CIRCUITO DI RODI COPPA TRICOLORE COP
 TE KLOSTERS-DAVOS AUV RENNEN WALLBERG-RENN
 RG GARA NAZIONALE DI SLALOM GRAN PREMIO TOUR
 ALLY INTERNAZIONALE 500 COPPA FIAT SLALOM AUTO
 COPPA PRIMAVERA DASCA AUTOSLALOM SARNANO-S
 (B-12,400 KMS) TRENTO-BONDONE (HILLCLIMB-17,300 K
 A RALLYE DE CANNES RALLYE EYEMO TROFEO ETTO
 SPIAZZI SLALOM DU MA
 ROPEEN CIRCUITO DI RIE
 COPPA BELMONTE FIN
 ANO FRASCATI-TUSCOLO
 NAZIONALI IN CIRCUIT R

STREET LEGAL

TRACK WORTHY

Understated is not an option when form meets the high-velocity performance functions of the FIAT® 500 Abarth. This is a union of highly engineered components and exclusive design elements.



New dual-valve
 KONI® Frequency
 Selective
 Damping (FSD)
 front shock
 absorbers
 provide ride
 comfort and
 body control
 for maximum
 grip and
 performance.

NEDETTO DEL TRONTO-ACQUAVIVA TRENTO-BONDONE COURSE DE
 DE GIVES PEDAVENA-CROCE D'ANNE CORSA DELLA CASTELLANA
 ANO-MENDOLA ADAC BERGRENEN SCALATA AL COLLE DELLA
 DALENA CRUSEILLES-LE SALEVE SARNANO-SASSOTETTO ROSFELD
 N BERGPREIS ALP BERGRENEN TRIESTE-OPICINA COPPA IEMONTE
 LLE D'AOSTA WALLBERG RENNEN EUROHILL BERGRENEN
 TELL'ARQUATO-VERNASCA BASSANO-MONTE GRAPPA WASGAU
 PREIS DURENER AUTOSLALOM FLUGPLATZRENNEN SEMBACH COPPA
 VERONA TRAPANI-MONTE ERICE CARESSIO-COLLE SAN BERNARDO
 A DELLA SIA 24 HEURES DE FRANCORCHAMPS GRAN PREMIO DEL

The architecture of the FIAT® 500 Abarth synthesizes with the road as it enhances the power of the 1.4L 16v MultiAir® Turbocharged engine. The aerodynamic styling reflects countless hours of wind tunnel sculpting and amplifies the legendary lines from any angle. The unique MacPherson strut front suspension with stiff spring rate and low ride height helps to give enhanced handling with minimal body roll. The lateral stiffness of cast-iron, front-lower control arms delivers improved grip and steering precision. The rear suspension's twist-beam design is strengthened with coil-spring supports for greater durability, as the Abarth® specific rear sway bar provides neutral handling.

The menacing low sprawl jockeys for placement, but it's more than its characteristic stance that makes up the extroverted Abarth personality. The front fascia's twin intercooler ducts deliver engine-cooling and power-inducing high-density airflow, while design elements such as a concentric dual exhaust system deliver Abarth tuned sound and maximum power. Elongated front and rear fascias accentuate its road-holding stance as the large liftgate-mounted spoiler adds downforce. The motorsports-inspired splitter optimizes aerodynamic airflow while minimizing drag.

PREDICTIVE BEHAVIOR

Adrenaline is best when applied wisely — this dynamic feature keeps it in check. The Abarth® tuned Torque Transfer Control (TTC) system is designed to stay one step ahead when it comes to cornering. It kicks into action by automatically distributing engine torque between the front wheels to minimize understeer and maximize traction. TTC is designed to control and transfer power to the drive wheels for world-class performance and improved at-the-limit handling. It operates with the Electronic Stability Control (ESC)^{1*} system to enable the FIAT® 500 Abarth to transfer torque from a front wheel that slips, to one that grips. TTC has been carefully honed on snowfields, icy grades, and racetracks to offer maximum traction in all conditions.



*A note about this brochure's all disclaimers and disclosures can be found on the back cover.





FOUR CYLINDERS. MASSIVE HEART.

Turbocharged, twin intercooled, and MultiAir® equipped 1.4L 16v engine delivers 160 horsepower and 170 lb-ft of torque.

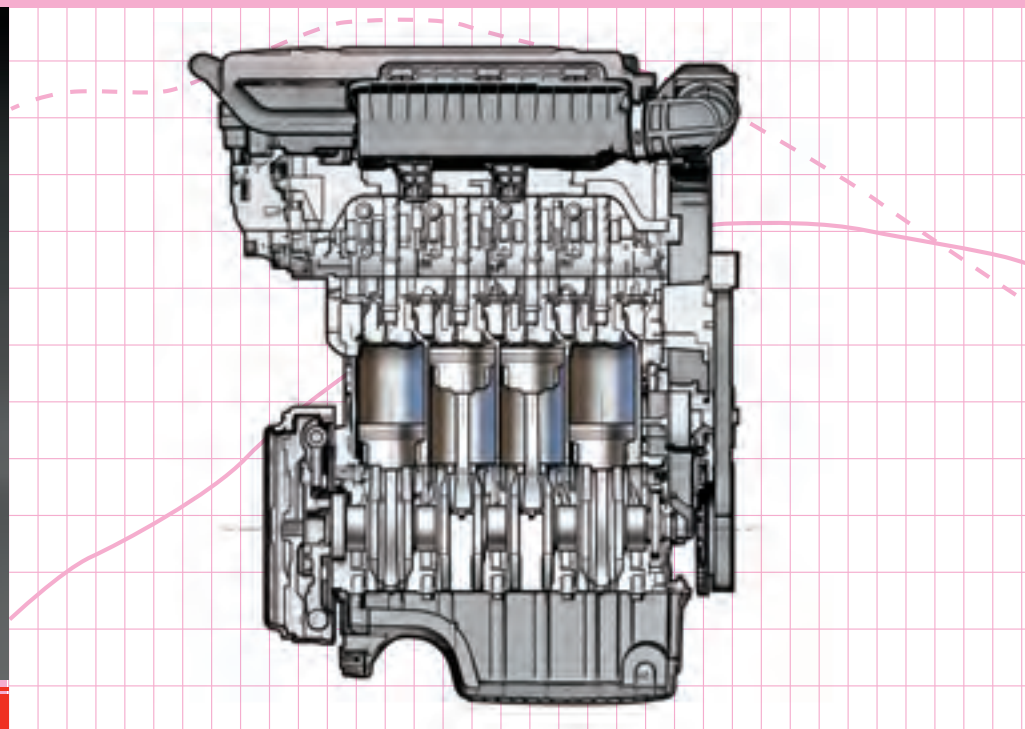

Herein lies the heart of the FIAT® 500 Abarth. Behind the unique Rosso Abarth® engine cover and Abarth designed front fascia (with twin intercoolers) beats an engine that delivers 160 horsepower and 170 lb-ft of torque. The all-new 1.4-liter 16v MultiAir® Turbocharged engine is backed by a manual five-speed transmission with 3.35 final-drive ratio for quick acceleration. The Abarth specific equal-length half shafts help reduce torque steer for optimized handling and control.

Like its legendary predecessors, this powerplant eschews convention for the sake of standout performance. The engine's lightweight forged-steel connecting rods have been designed with a unique cross-section for strength and durability while a high-flow fresh-air intake system with air box maximizes power with low induction noise. A turbocharger converts exhaust heat and pressure while the MultiAir technology takes into account the split-second changes and adjusts accordingly. The end result? A 10% fuel efficiency improvement over conventional engines.

160 HORSEPOWER

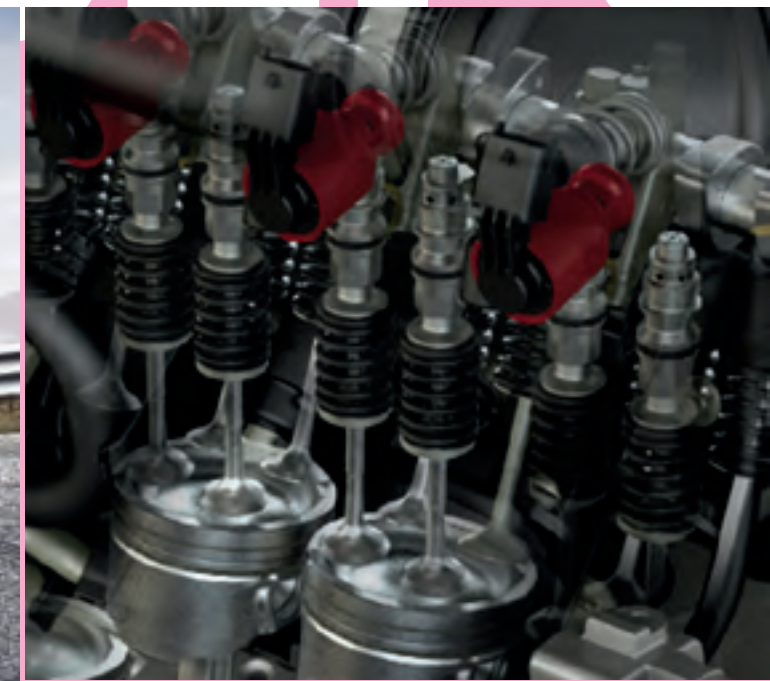



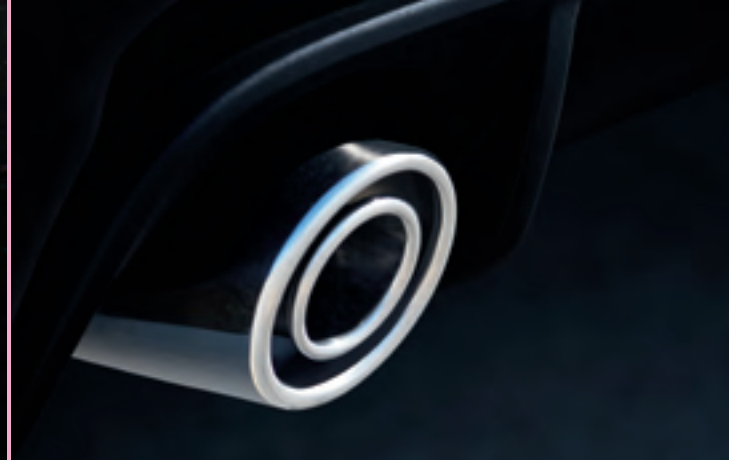



Proprietary side-sill ground effects provide a vertical and athletic profile as optional contrasting-color side mirrors and graphics enhance the brazen look. Available lightweight 17" x 7" forged aluminum wheels with Three-Season Pirelli® ultra high-performance tires beckon the track.

Its emblem defies ornamentation, as it adorns the front, rear, sides, and inside of the FIAT® 500 Abarth. Born of Karl Abarth's astrological sign, the Abarth® Scorpion serves to exemplify this creature's tenacity. The center hubs' scorpions hint at the potency of the unique front brake rotors and calipers and semimetallic brake pads that have capable claws all their own. The distinctive symbol is also etched in places that can only be appreciated by those inclined to get under the body for a closer look.





High performance meets high fidelity with new Beats Audio™ Premium Sound System for FIAT® 500 Abarth.

We tapped famed ear-candy confectioners Dr. Dre and Jimmy Iovine to help fill the Abarth® cabin with an acoustic experience that's more club than cockpit. This legendary partnership between producers and engineers meticulously mapped sound waves and designed algorithms specific to FIAT® 500, creating what is, essentially, a rolling Beats Audio product — the first one in its segment. Six premium speakers, an 8-inch Dual-Voice Coil (DVC) subwoofer, and an 8-channel 368-watt amplifier with Beats Audio Digital Sound Processing (DSP) algorithm means you'll feel every low and detect every high — just the way the musicians intended. It's as if you're right there in the studio with Dr. Dre and Mr. Iovine themselves.

CONTROL CENTER

CRAFTSMANSHIP INGRAINED

A performance-designed cockpit makes room for all the perks that make a driving cabin worth riding in.

Extreme craftsmanship shows itself in the handsome soft upper panel and leather-wrapped instrument cluster brow with detailed Rosso stitching. A classic center panel and emboldened air outlets add to the interior's appeal. The easy-to-reach center stack, leather-wrapped park brake handle, shift knob, and three-spoke leather-wrapped steering wheel with shaped thumb rests and flattened bottom are motorsports-inspired, comfortable touch-points. Performance cloth high-back bucket seats, also available in leather trim, are constructed with unique Rosso stitching and incorporate a racing harness pass-through. Firm side bolsters keep the driver in place and give feedback during spirited driving without sacrificing long-distance comfort. The EZ-Entry pull strap design enhances rear seat entry and exit.

The instrument cluster is illuminated with an easy-on-the-eyes Liquid Crystal Display (LCD) and driver-selectable Electronic Vehicle Information Center (EVIC) with trip computer. The lighting and location of these features give the driver heightened road and track confidence while functional backlighting enhances read-out visibility of fuel, temperatures, driving range, and other gauges. The BLUE&ME® Hands-Free Communication System² and the Speed Control can be operated via steering wheel-mounted controls. The radio function controls are found on the reverse side of the steering wheel spokes. The Abarth® Scorpion badge is prominently displayed on the center of the steering wheel for distinctive attitude.





+ DECKING THE DECKED: Ambient Light Kit.



AUTHENTIC PERFORMANCE PARTS AND ACCESSORIES BY MOPAR.

TAKE IT UP A NOTCH.

Amplify an already serious punch with performance parts designed specifically for the FIAT® 500 Abarth. It's a lifestyle that's forged with a zest for living in the fast lane. Mopar brings it on with a wide range of Authentic Abarth® Performance Parts, including Brake Kit, Sway Bars, Cat-Back Exhaust, and more. They deliver increased stopping power, improved handling, and reduced restriction. This is the equipment you need to let like-minded performance enthusiasts know you're serious.

WIDEN THE RANGE.

Mopar also offers both interior and exterior Authentic FIAT 500 Abarth Accessories that pack some punch when it comes to added style and functionality. Opt for Ambient Light Kits, Chrome Mirror Covers and Fuel Filler Door, Roof-Mount Carriers, and much more.



ESC

ELECTRONIC STABILITY CONTROL (ESC)¹ The standard Abarth[®] tuned three-mode ESC¹ with four-wheel Antilock Braking System (ABS) allows adaptability for changing driving conditions. The default Full ON mode provides maximum traction control for normal, everyday driving. The driver-selected Partial OFF allows limited wheel slip for more aggressive high-performance driving dynamics, while Full OFF disables traction control completely for the experienced track-driving enthusiast. ESC¹ enhances driver control and helps maintain directional stability under critical driving situations, such as when snow, ice, or gravel are factors. When the system senses a difference between driver input and the vehicle path, it applies selective braking and throttle input to guide the vehicle back onto the driver's intended path.

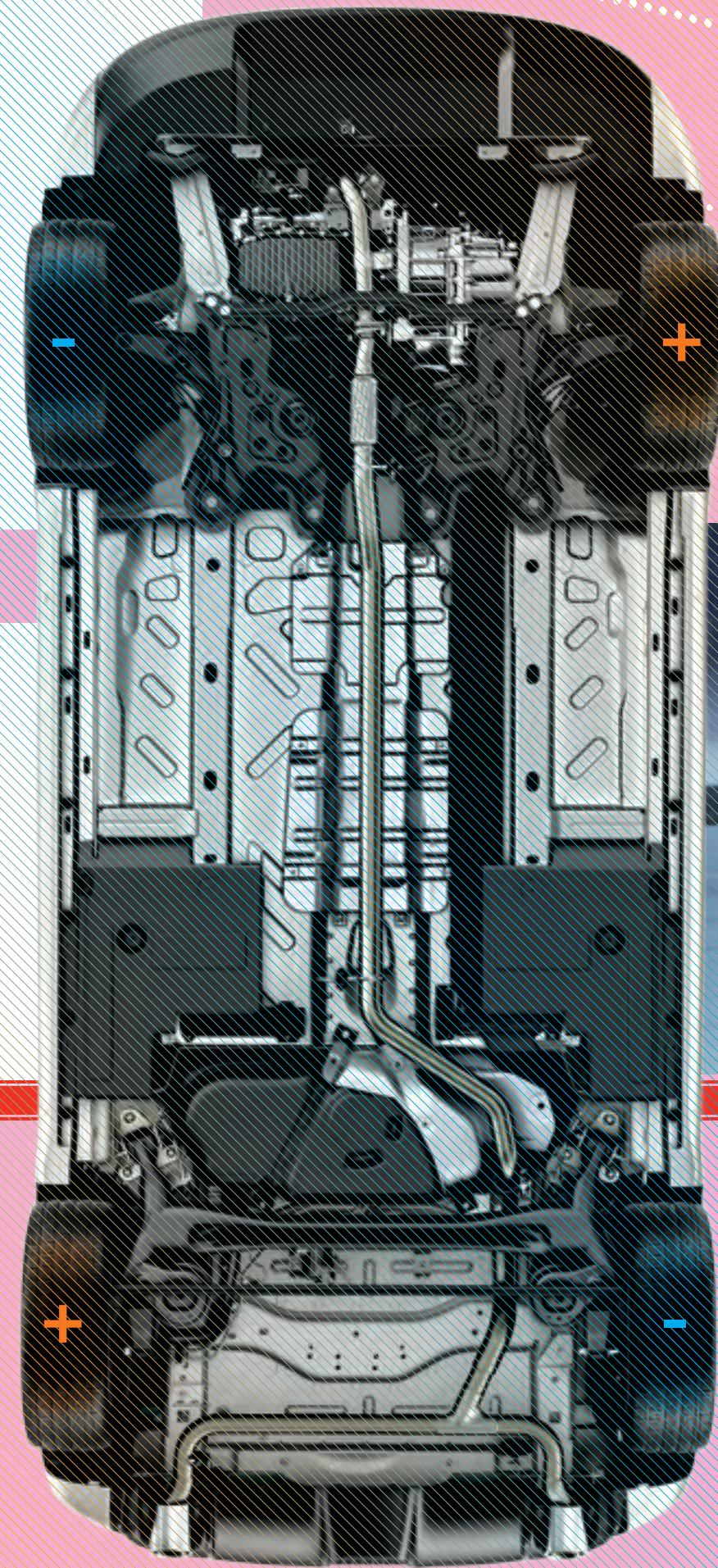

ESC¹ instantly analyzes input from the wheel sensors and corrects any pending loss of control by applying any one, several, or all of the system's disc brakes as needed.

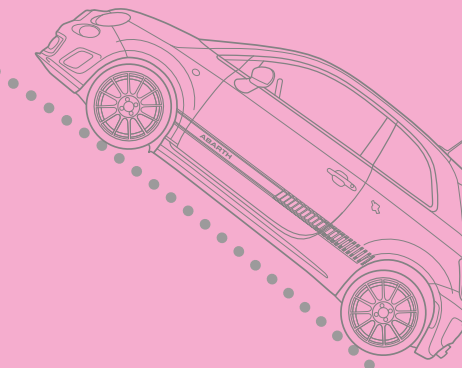

Hill Start Assist This standard safety feature assists drivers when starting a vehicle from a stop on a hill. It automatically maintains the level of brake pressure applied for a short period of time after the driver's foot is removed from the brake pedal, helping prevent rollback on hills and inclines.



THE MOST CRUCIAL TYPE OF PERFORMANCE

The Abarth[®] name may stand for competition but when it comes to safe driving, there's no contesting that FIAT[®] 500 Abarth means business. And merging a performance machine to the level of an everyday refined vehicle means a robust group of active and passive safety and security features have been included. The seven air bags⁴ throughout the cabin and a host of innovative technologies help keep occupants comfortable, secure, and connected.





16 x 6.5-INCH CAST ALUMINUM IN GRIGIO
WITH PAINTED POCKETS STANDARD

17 x 7-INCH FORGED ALUMINUM
IN NERO OPTIONAL

17 x 7-INCH FORGED ALUMINUM
IN BIANCO OPTIONAL

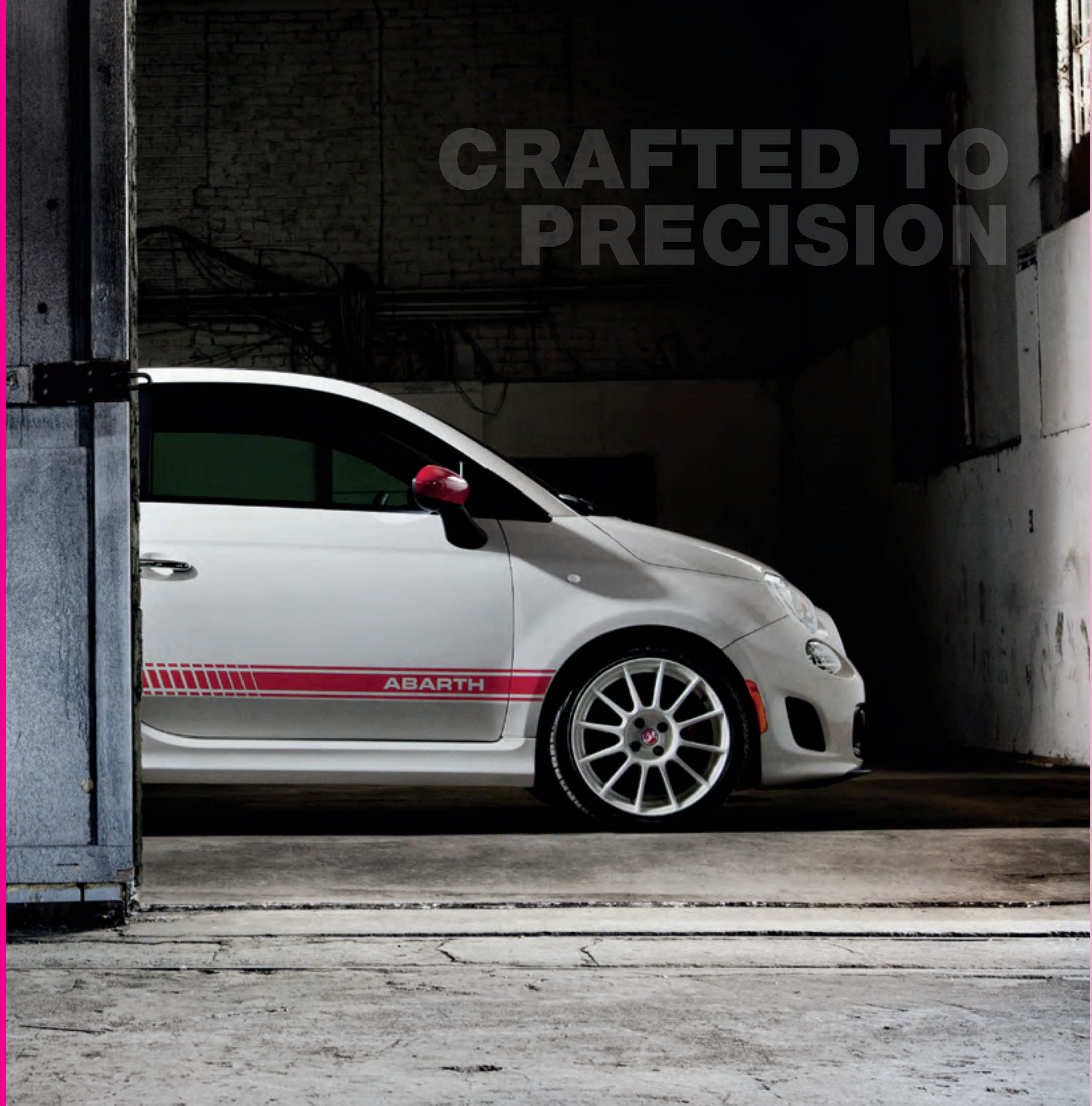

CRAFTED TO
PRECISION

NERO

GRIGIO



BIANCO

ROSSO



NERO LEATHER TRIM
OPTIONAL



ROSSO LEATHER TRIM
OPTIONAL



NERO CLOTH
STANDARD





Nero stripe and mirror cap available on Grigio, Bianco, and Rosso. Rosso stripe and mirror cap available on Bianco, Grigio, and Nero. Bianco stripe and mirror cap available on Rosso, Nero, and Grigio.

Body-color mirror caps. Standard.

SPECIFICATIONS

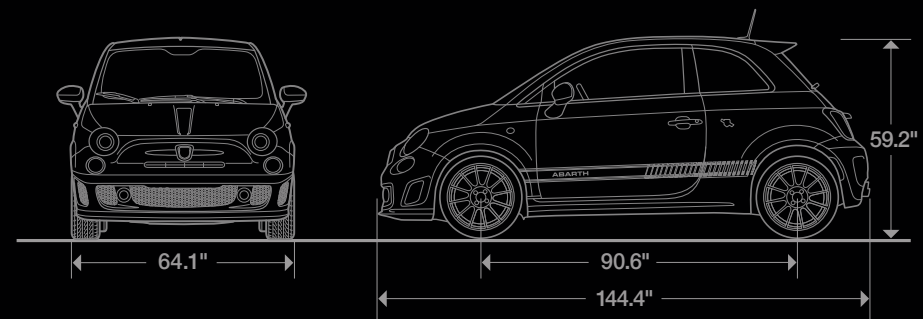

POWERTRAIN

Engine – 1.4L 16v MultiAir® Turbocharged inline four-cylinder engine	S
Electronic Throttle Control (ETC)	S
Engine block heater	O
Engine cover with Abarth® logo	S
Drive system – Front-Wheel Drive (FWD)	S
Transmission – 5-speed manual transmission	S

ELECTRICAL

Alternator – 120-amp	S
Battery – 500-amp, maintenance-free	S
Power accessory delay	S

CHASSIS

Performance four-wheel disc brake system	
11.1-inch vented-front rotors with single-piston calipers	S
9.4-inch solid-rear rotors with single-piston calipers	S
Rosso-painted brake calipers	S
Semimetallic brake linings	S
Clutch-brake interlock	S
Fuel tank – 10.5-gal. (40L) capacity	S
Steering	
Electric Power Steering (EPS), variable-speed assisted sensitivity, power rack-and-pinion	S
Sport mode with unique calibration	S
Suspension (front)	
MacPherson suspension, coil spring with KONI® Frequency Selective Damping (FSD) twin-tube shock	S
Suspension (rear)	
Rear twist-beam axle with coil springs and twin-tube shock absorbers	S
Tires	
195/45R16XL Pirelli® Cinturato P7 All-Season Performance	S
205/40R17 Pirelli P Zero Nero Three-Season Performance (included with 17 x 7.0-inch forged aluminum wheels)	P
Tire repair kit	S
Wheels	
16 x 6.5-inch Abarth designed cast aluminum Grigio with painted pockets	S
17 x 7.0-inch Abarth designed forged-aluminum finished in Nero	O
17 x 7.0-inch Abarth designed forged-aluminum finished in Bianco	O

EXTERIOR

Antenna – roof-mounted	S
Abarth badges – front fascia, liftgate, bodyside	S
Belt molding – Nero (Black)	S
Bodyside – body-color, Abarth designed sill	S
Door handles – chrome	S
Exhaust tips – Abarth designed, dual	S

EXTERIOR (continued)

Fascia (front)	
Two-piece Abarth designed with body-color surround, brake cooling ducts, intercooler “nostrils,” and “Whiskers and logo” face with functional cooling behind Abarth front fascia badge	S
Fascia (rear)	
Two-piece Abarth designed with body-color upper, honeycomb grille accents, and lower diffuser	S
Fuel door – non-locking	S
Glass – solar-tinted	S
Lamps	
Bi-halogen projector headlamps	S
Lower turn signal lamps	S
Halogen fog lamps	S
Center High-Mounted Signal Lamp (CHMSL)	S
License plate brow – chromed with 500 logo	S
Mirrors	
Body-color power adjustable, heated, foldaway with driver-side spotter mirror	S
Power sunroof – vent and one-touch express open	O
Spoiler – Abarth designed, liftgate-mounted, body-color	S
Wiper system – speed-sensitive, variable-intermittent	S

INTERIOR

Carpet – with acoustic foam and foam-in-place padding noise barrier	S
Cargo area – liftgate liner, rear cargo shelf panel, rear cargo area lamp	S
Climate control	
Air conditioning	S
Automatic Temperature Control (included with the Comfort/Convenience Package)	P
Cabin air filtration	S
Console – floor console	S
Three front-passenger cup holders	S
12-volt power outlet	S
Two rear-passenger cup holders	S
Cruise control – steering wheel-controlled	S
Door panels	
Chromed die-cast hook door handles with integrated power door locks	S
Driver and passenger armrests, coordinated with seat color	S
Map pockets	S
Floor mats – premium with embroidered Abarth logo	S
Headliner	
Sun visors with vanity mirrors	S
Front-passenger assist handle	S
Front overhead console with map lights	S
Rear coat hooks	S
Instrument cluster	
Concentric design with 160-mph primary	S
Leather-wrapped cluster brow with accent stitching	S
Driver's selectable Electronic Vehicle Information Center (EVIC) with trip computer, outside temperature, average fuel economy, distance-to-empty, low fuel, service interval, and driving range	S
Tachometer, engine temperature, and fuel gauge	S

INTERIOR (continued)

Turbo boost gauge with integrated shift light	S
Instrument Panel	
Exterior-color-matched	S
Front-passenger glovebox with dampened door	S
Key fob – remote keyless entry with folding shank	S
Multimedia systems	
AM/FM/CD/MP3/WMA radio	S
Auxiliary input jack	S
SiriusXM Satellite Radio ⁵ (included with the Safety and Convenience Package)	P
Alpine® Premium Audio, includes 276-watt amplifier with six speakers	S
Beats Audio™ Premium Audio Package – includes six premium speakers, 8-inch Dual-Voice Coil (DVC) subwoofer with trunk-mounted enclosure, eight-channel 368-watt amplifier with Beats Audio Digital Sound Processing (DSP) algorithm, and SiriusXM Satellite Radio ⁶	O
BLUE&ME® Hands-Free Communication ² includes voice-activated communication system with Bluetooth® phone capability and USB port with iPod® control	S
TomTom ^{®3} Navigation includes a 4.3-in. touch-screen TomTom handheld navigation unit	O
Pedals – aluminum with rubber grip	S
Rearview mirror – manual day/night adjust	S
Seating (front)	
Nero/Rosso (Black/Red) cloth performance seating	S
Nero (Black) leather performance seating	O
Rosso/Nero (Red/Black) leather performance seating	O
Driver-side armrest	S
Driver's seat with manual height adjuster	S
Driver's seat EZ-Entry and seatback memory	S
Front seatback pockets	S
Seating (rear)	
50/50 split/fold-down seat	S
Lower Anchors and Tethers for Child Seats (LATCH)	S
Shift knob – leather-wrapped, with accent stitching	S
Steering wheel	
Abarth® performance-designed	S
Perforated-leather wrapped	S
Audio and cruise controls	S
EVIC controls	S
Steering column with manual tilt	S
Windows	
Front power with express one-touch down	S
Rear-window defroster	S

SAFETY AND SECURITY

Air bags ⁴	
Advanced multistage driver and front-passenger ⁴	S
Front and rear side-curtain ⁴	S
Driver's inflatable knee ⁴	S
Driver and front-passenger seat-mounted side ⁴ (pelvic-thorax)	S
Antilock Brake System (ABS)	S
Active turn signals	S
All-speed Traction Control System (TCS)	S
BeltAlert, passenger seat	S
BLUE&ME Hands-Free Communication ²	S

SAFETY AND SECURITY (continued)

Brake Assist	S
Constant-Force Retractors (CFR)	S
Crumple zones	S
Daytime running lamps	S
Electronic Brake-Force Distribution (EBD)	S
Three-mode Electronic Stability Control (ESC) ¹	S
Energy management system	S
Hill Start Assist (HSA)	S
Intelligent Battery Sensor (IBS)	S
Lower Anchors and Tethers for Child Seats (LATCH)	S
Occupant Restraint Controller (ORC)	S
Remote keyless/illuminated entry system	S
Seat belts – includes three-point for all positions	S
Tire Pressure Monitoring Display	S

PACKAGES

Comfort/Convenience Package	
Includes automatic climate control, heated front seats, and SiriusXM Satellite Radio ⁵	O
Smoker's Package	
Includes cigar lighter and ashtray	O
Exterior Accent Equipment	
Rosso (Red) mirror caps (includes Abarth bodyside stripe; not available with Rosso exterior paint)	O
Nero (Black) mirror caps (includes Abarth bodyside stripe; not available with Nero exterior paint)	O
Bianco (White) mirror caps (includes Abarth bodyside stripe; not available with Bianco exterior paint)	O

S - Standard
P - Packaged
O - Optional

