



► The 2008 Audi A3





Audi A3 2.0 TFSI shown.

Defy expectations.

Proof that an urban car can also be decidedly urbane.



Audi A3 2.0 TFSI with optional equipment shown.



**Right car. Right time.**

**Beyond functional, genuine fun.**

Introducing the 2008 Audi A3. With the choice of 200 or 250 hp engines, exemplars of effective, efficient power. The 2.0 T, 2.0 T with Premium or S line packages as well as the 3.2 S line also feature innovative transmission and drivetrain options. For 2008: More standard features, new colors, new wheel offerings, new options and more. Proof that one company believes that size shouldn't determine who gets the best in design, technology, performance and safety.



To the joy of coming home,  
add the thrill of getting there.

Audi A3 2.0 TFSI shown.

The key to making a more compact car feel positively expansive rests in the details.



We invite you to examine the 2008 A3 closely. Check the gap tolerances. Listen closely when you close the doors. Run your hand over its smooth paint. No doubt about it: This is a German luxury car through and through. From its bold single-frame grille to its discreet rear spoiler, every bit an Audi.



Exterior details matter: From polished tailpipes to new 17" and 18" wheels to optional new exterior trimmings, the A3 proves, like a diamond ring, that great things come in unexpectedly small packages. Forever dispensing with the notion that luxury must be synonymous with large.



Flanking its bold grille and the subtle V of its sloping hood are optional bi-xenon headlights with Audi adaptive light. In addition to light-up-the-night intensity, these remarkable headlights help to illuminate what's around the next corner. And in a car like this, there will be scores of corners ahead. Front fog lights are standard on 3.2 S line models and optional on 2.0 T models.



But details don't tell the whole story. For that you have to stand back and see the A3 for what it is: A strikingly beautiful example of both form and function in complete harmony. A winning combination of athleticism and subtle grace.

One look at the A3 is enough to give the heart rate a boost.



**The S line package: When it comes to personalizing your A3, we've got you covered.**

From its S line-specific bumpers to its roof-mounted spoiler to special badging, there's no doubt this A3 is designed to turn heads. And that's before you experience the Sport suspension. Proud beneficiary of the design and performance expertise of quattro GmbH, an A3 with the S line package demonstrates to one and all the jewel-like precision of your decision. From brushed aluminum trim, well-bolstered Sport seats with leather seating surfaces, a power driver's seat with lumbar adjustments and more, this A3 makes its intention clear. Even before you turn the key.

And then we take it to the next level – with options such as the distinctive Titanium package. From 18" titanium-colored, seven-arm double-spoke wheels, a black grille, Piano Black interior trim and a black headliner, Titanium rules. For S line package devotees, a logical next step.

A three-spoke multi-function steering wheel with paddle shifters awaits those who choose the super-quick, dual-clutch S tronic™ transmission. Standard on 3.2 models, optional on the 2.0 T.

A brushed aluminum trim accents the sporty S line package interior.

With distinctive badging in the front door sills, you're reminded of your decision to opt for the S line package every time you step in. The Sport suspension serves as yet another cue that you made the right choice.



Audi A3 3.2 S line shown.



Open sky: Let there be light.

For all, for some – it's your call.



With two panes, one tilt-and-slide and the other fixed, the optional Open sky system means things are definitely looking up for some A3 drivers. A handy wind deflector keeps noise and drafts inside to an absolute minimum. But even when Open sky is closed, the view is magnificent. For every occupant.



Open sky serves as a counterpoint to the sports-car beltline of the A3. And it typifies our goal of ensuring that our smaller cars have many of the same features of larger offerings. From available sunshades for the rear seats to the amenities of our popular Premium package, abundant proof that less is often more. Not just in design, but throughout the vehicle.



Let the sunshine in.  
Or keep it out. It's up to you.



**Part TT, part A8, part A6: All A3.**

With interior touches from the TT, the MMI® logic of the A8, the material excellence typical of all our cars, dual-zone climate controls and optional heated front seats, the 2008 A3 makes it rather obvious that our goals match yours. After all, bigger isn't always better. Luxury, you see, isn't a function of size.

And yet size mandates an ever-greater need to pay attention to each and every detail. From its driver-centric cockpit to the intuitiveness of every switch and dial, an ergonomic and aesthetic gem. With an athleticism that positively begs you to settle in, turn the key and go.



An optional ski sack and standard 60/40 split-fold rear seats make getting there as much fun as being there.

Audi A3 2.0 TFSI with optional equipment shown.





Staying in front of the curve  
means taking a backseat to no one.



With optional Audi Navigation plus, getting around town or finding a great Thai restaurant is easy. Thanks to the MMI-inspired logic of our controls. And since we want you to keep your hands on the wheel, Bluetooth® interface is now optional on A3 models with the Premium or S line package. Our goal with all of this technology is simple: Make it accessible. And make it super easy to use.



Whether you opt for the Sport seats in the S line package or the supportive seats of the 2.0 T Premium package, rest assured you're getting the same attention to every stitch, every detail found in all of our cars. To our way of thinking, seats are a vital component in making sure you're alert and attentive.



With an optional iPod® adaptor in the glove compartment or optional SIRIUS® satellite radio, there'll be no shortage of tunes in your world. With 10 speakers, complete with an in-fill subwoofer, the Audi Symphony does everything but demand a standing ovation. The Audi Concert, standard on 2.0 T models, features Radio Data System (RDS) as well as Graduated Audio Level Adjustment (GALA).



The only drawback to the finely calibrated decibels of our sound systems – you may find the sound in your living room wanting more richness, more depth, more clarity, more soul.

There will be times when the best seats in the house aren't even in the house.



Passengers are not an afterthought in the A3. From bolstered seats to cargo netting to integrated arm rests to pre-tensioning seat belts to LATCH attachments for child safety seats, our desire is to engage, protect and delight every occupant. Even the ones who can't express it yet.



**Pick the right drivetrain and you  
can choose any road you want.**

You can endlessly debate handling prowess and the merits of front-, rear- and all-wheel drive. But when the weather turns, the debate ends. After years of real-world experience, we're firmly convinced that the tractive power of front-wheel drive and legendary quattro® all-wheel drive offer a superior skill set when conditions are less than ideal. To our way of thinking, it's all about taking a more aggressive approach to handling.

In addition to championing front- and all-wheel drive, Audi has spent years sharpening the handling skills of our cars. With MacPherson struts up front and a four-link suspension with separated shocks and springs at the rear, the A3 reads roads with uncanny precision. The Sport suspension on S line models further pinpoints handling. In addition to mechanical brilliance, the A3 benefits from an Electronic Stability Program (ESP®) that provides yet another level of control. Whether it's a trip across town or one across the country, the A3 shines. It all adds up to a driving experience where grinning comes standard.

## The will to win is in our DNA.

FSI® Direct Injection made its competitive debut in winning the 2001 24 Hours of Le Mans. You'll now find it on every A3 2.0 T model. After all, making more power from less fuel wins races. And fans. In 2006, our R10 TDI became the first diesel-powered vehicle to capture the 24 Hours of Le Mans. Just the beginning, we might add. In 1980, we showed the world how luxury vehicles offering all-wheel drive could be an everyday phenomenon. Thanks to quattro, that day has arrived.

Our goals in motorsports are simple. To be sure, we strive to win. But we're equally committed to finishing what we start. There is no better venue than the heat of competition to find out what works. And what still needs more work.





You can feel the precision in every part.  
Every time you move.



Making more from less is the idea behind FSI Direct Injection. The actual fulfillment of that ideal is up to you. A 2006 winner of *Ward's AutoWorld* 10 Best Engines in the world, the 2.0 TFSI packs a turbocharged punch and then adds class-leading efficiency. Injecting fuel directly into the cylinders creates a more precise fuel/air mixture than traditional port injection setups. With 207 lb-ft of torque between 1800 and 5000 rpm, power delivery that's smooth in the extreme. And when you hear it sing, you'll echo its praises as well.



With MacPherson struts in front and a four-link setup in the rear, the A3 handles with both ease as well as a sense of purpose. Our goal is to transmit the information that you need while filtering out the extraneous. A balancing act the A3 performs brilliantly.

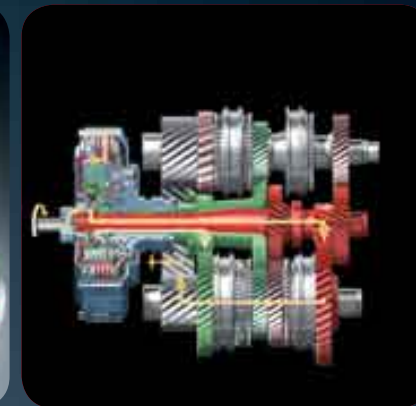

Not even a professional driver can match the shifting speed of our S tronic transmission. When one gear is engaged, the next gear is already pre-selected. Shifts occur in less than .2 seconds. The result: Virtually no loss in propulsive force as you move rather smartly down the road. And while the six-speed manual standard on the 2.0 TFSI models is decidedly quick, the S tronic, complete with paddle shifters on the steering wheel, has been widely praised by drivers and journalists as best of breed.



In the 3.2 S line, the 250 hp V6 benefits immensely from Audi expertise in aluminum. The engine's construction is complemented by our determination to incorporate copious amounts of lightweight aluminum in both the front and rear suspensions.

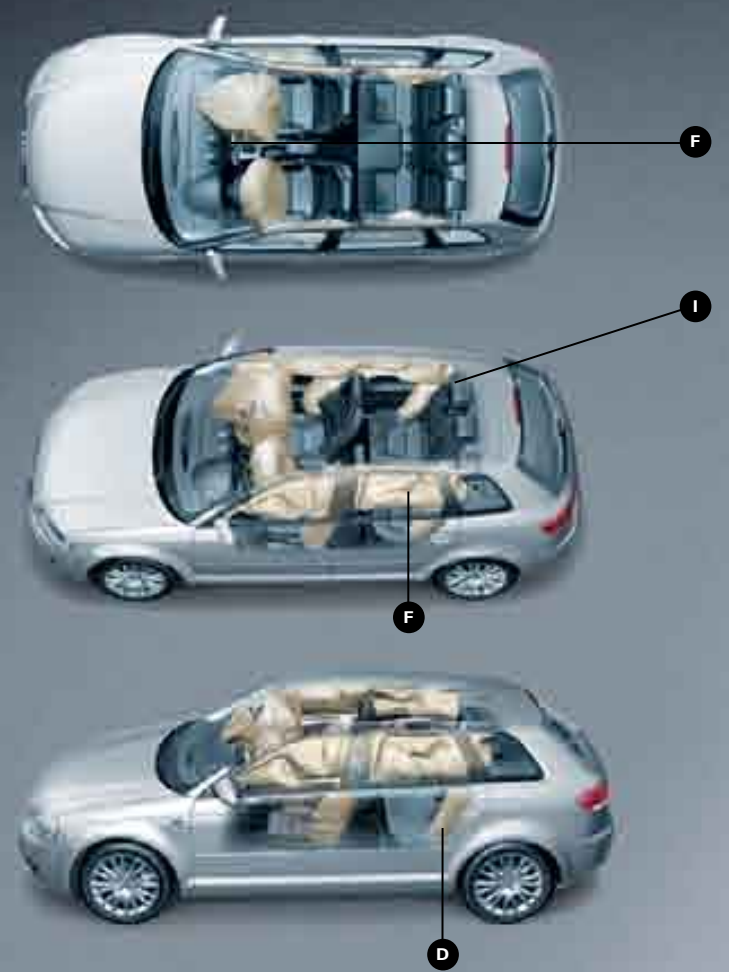

**A car as capable as the A3 deserves nothing less than everything we've ever learned about safety.**

At Audi, safety starts with actively avoiding accidents. Sharp handling, strong brakes and an overall environment that fosters confidence. But should the unthinkable become unavoidable, we're there for you. With six standard airbags\* (eight optional), including comprehensive Sideguard® protection, the 2008 A3 offers the kind of overall protection previously unimagined in the class. In Insurance Institute for Highway Safety (IIHS) crash tests, the A3 scored "Good" ratings (highest possible) in both frontal offset and side-impact crash tests\*\* More proof that Audi believes strongly in offering drivers and passengers of all of our cars a higher level of security.

- A** Pre-programmed deformation areas.
- B** Child-protecting LATCH seat attachments.
- C** ABS anti-lock brakes at all four wheels.
- D** Optional seat-mounted side airbags for rear passengers\*.
- E** Convex-shaped critical components of reinforced steel for added side-impact protection.
- F** Seat-mounted side airbags for driver and front passenger\*.
- G** ESP supplemented by other electronic assists.
- H** Dual-stage, dual-threshold front airbags\*.
- I** Comprehensive Sideguard protection\*.

\*Airbags are supplemental restraints only and will not deploy under all accident circumstances. Always use safety belts and seat children only in the rear, using restraint systems appropriate for their size and age.

\*\*Based on 31 mph side-impact crash test, 40 mph frontal offset crash test performed by the Insurance Institute for Highway Safety. For details, see [www.iihs.org](http://www.iihs.org).

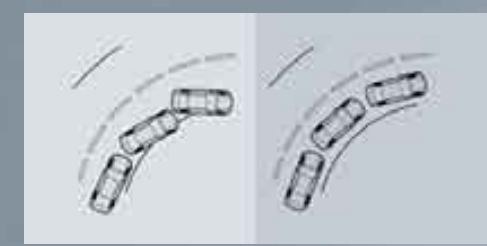

The standard Electronic Stability Program (ESP) in every A3 is an example of how electronics and mechanical brilliance can work together.

At Audi, safety isn't one thing like an airbag or stronger steel. At Audi, safety is everything.



You've found just the car you want.  
Now it's time to dress it up.



What kind of wheels will your wheels sport? We offer an 18" wheel designed to enhance the A3's appearance. But don't stop there. Talk to your dealer or visit [audiusa.com](http://audiusa.com) to see what else is available.



Here's proof that all-weather mats can add to the style of your A3 and not detract from it. Designed to contain all manner of mess – rain, snow, sand and mud. Proof that form and function are never mutually exclusive.



What will you be taking on your next weekend? Skis, bikes, snowboards or just extra luggage – when you opt for the base rack, the possibilities to refine it are nearly endless. And expertly designed to secure and protect your valuables.

Audi A3 2.0 TFSI with optional equipment shown.

Make your A3 totally yours.  
And yours alone.



Audi A3 2.0 TFSI with optional equipment shown.

### Audi A3 Specifications

#### Power and Performance

<b>A3 2.0 T</b>	<ul style="list-style-type: none"> <li>▶ 200 hp – DOHC in-line 2.0 liter four-cylinder with FSI® Direct Injection, variable valve timing, intake manifold and exhaust turbocharger with intercooler</li> <li>▶ Displacement: 121.06 cu. in.</li> <li>▶ Bore: 3.25 in.</li> <li>▶ Stroke: 3.65 in.</li> <li>▶ Compression ratio: 10.3:1</li> <li>▶ Horsepower: 200 hp @ 5100-6000 rpm</li> <li>▶ Torque: 207 lb-ft @ 1800-5000 rpm</li> <li>▶ 0-60 mph in seconds: 6.7</li> <li>▶ Top track speed<sup>1</sup>: 130 mph</li> <li>▶ Fuel economy estimates, city/highway<sup>2</sup> – S tronic: 22/29 mpg manual: 21/29 mpg</li> </ul>
-----------------	--

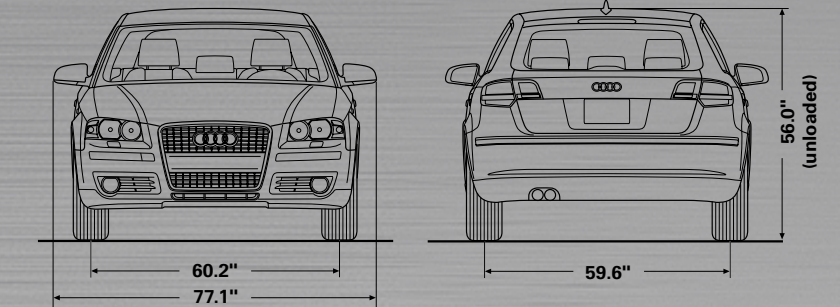
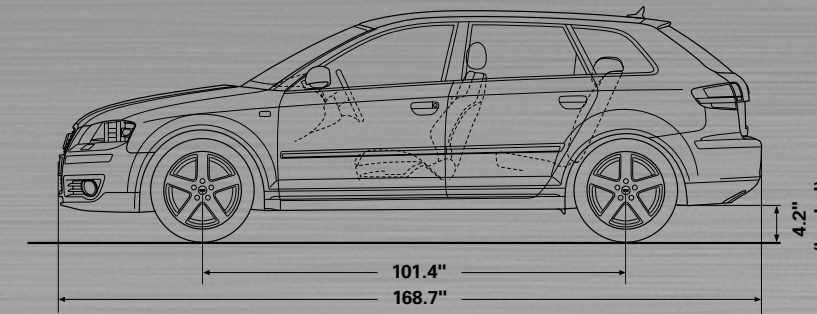

#### Model Configurations

- ▶ Audi A3 2.0 TFSI 200 hp with six-speed S tronic™ transmission and front-wheel drive
- ▶ Audi A3 2.0 TFSI 200 hp with six-speed manual transmission and front-wheel drive
- ▶ Audi A3 3.2 S line 250 hp with six-speed S tronic transmission and quattro® all-wheel drive

#### A3 3.2 S line

	<ul style="list-style-type: none"> <li>▶ 250 hp – DOHC spark ignition, front-mounted transverse in-line 3.2 liter V6 and variable valve timing</li> <li>▶ Displacement: 190.57 cu. in.</li> <li>▶ Bore: 3.31 in.</li> <li>▶ Stroke: 3.78 in.</li> <li>▶ Compression ratio: 11.3:1</li> <li>▶ Horsepower: 250 hp @ 6300 rpm</li> <li>▶ Torque: 236 lb-ft at 2800-3200 rpm</li> <li>▶ 0-60 mph in seconds: 5.9</li> <li>▶ Top track speed<sup>1</sup>: 130 mph</li> <li>▶ Fuel economy estimates, city/highway<sup>2</sup>: 18/25 mpg</li> </ul>
--	--

<sup>1</sup>Top track speed electronically limited to 130 mph in the U.S.

<sup>2</sup>Your mileage may vary.



A3 2.0 T	A3 2.0 T S line package	A3 2.0 T Premium package	A3 3.2 S line	Wheels
S	n/a	n/a	n/a	(A) 17-inch five-spoke cast alloy wheels with 225/45 all-season tires
n/a	n/a	S	n/a	(B) 17-inch eight Y-spoke bi-color cast alloy wheels with 225/45 all-season tires
n/a	S	n/a	S	(C) 17-inch five-arm cast alloy wheels with 225/45 all-season tires
n/a	O	n/a	O	(D) 18-inch five-arm quattro GmbH cast alloy wheels with 225/40 all-season or summer performance tires*
n/a	O	n/a	O	(E) 18-inch seven double-spoke Titanium color quattro GmbH cast alloy wheels with 225/40 all-season tires

S = standard O = optional n/a = not applicable

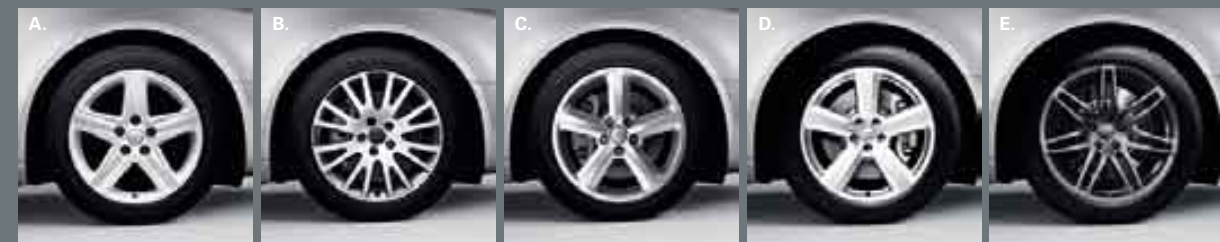

\*Summer performance tires available on 3.2 models only. These tires are designed for optimum performance and handling in warm climates. They are not suitable for cold, snowy or icy weather conditions. If you drive under those circumstances, you should equip your vehicle with all-season or winter tires, which offer better traction under those conditions. We suggest you use the recommended winter or all-season tires specified for your car or its equivalent. These summer performance tires also have a lower aspect ratio that aids performance and handling; however, in order to avoid tire, rim or vehicle damage, it is important that the inflation pressure is regularly checked and maintained at recommended levels. Please also remember in making your selection that, while these tires deliver responsive handling, they may ride less comfortably and make more noise than other choices. Finally, these tires may wear more quickly than other choices. For more information on all of these topics, please consult the owner's manual, your local dealer or call 1-800-FOR-AUDI.

A3 2.0 T	A3 2.0 T S line package	A3 2.0 T Premium package	A3 3.2 S line	
				<b>Suspension / Body</b>
S	S	S	S	Front suspension: MacPherson struts, aluminum subframe, tubular anti-roll bar
S	S	S	S	Rear suspension: Four-link suspension with separate spring/shock absorber arrangement
n/a	S	n/a	S	Sport suspension
S	S	S	S	Electromechanical steering with speed-dependent power assistance; turning circle: 35.1 ft.
S	S	S	S	Two-sided fully galvanized body, multi-step anti-corrosion protection, aluminum hood
				<b>Exterior</b>
S	S	S	S	Power rear window wiper
S	S	S	S	Black trim around side windows
n/a	S	n/a	S	S line bumpers
n/a	S	n/a	S	Roof spoiler
S	S	S	S	Aerodynamic ellipsoid projector headlights with variable focus reflectors, integrated low and high beam tubes, polycarbonate covers
S	S	S	S	Side indicator lights located in front fenders
n/a	S	S	S	Front foglights
				<b>Safety / Security</b>
S	S	S	S	Electronic Stability Program (ESP®)
S	S	S	S	Anti-lock brake system with vacuum power assist, Electronic Brake-pressure Distribution (EBD) and hydraulic Brake Assist
S	S	S	S	Sideguard® head protection airbags* for front and rear occupants
S	S	S	S	Driver and front passenger next-generation airbag* supplemental restraints
S	S	S	S	Driver and front passenger seat-mounted chest side airbags*
S	S	S	S	Front three-point safety belts with automatic pre-tensioning, height-adjustable upper mounts and force limiters
S	S	S	S	Three rear three-point safety belts with automatic pre-tensioning
S	S	S	S	Front passenger and rear safety belts with convertible locking retractors
S	S	S	S	Power central locking system with safety unlock feature if airbag deploys
S	S	S	S	Tire-pressure monitoring system
S	S	S	S	Lower Anchors and Tethers for Children (LATCH) in rear seats
S	S	S	S	Child safety rear door locks
S	S	S	S	Reflectors in rear of all doors
S	S	S	S	Anti-theft vehicle alarm system
				<b>Electronics</b>
S	S	S	n/a	Audi Concert AM/FM stereo with in-dash CD player, Radio Data System (RDS) and Graduated Audio Level Adjustment (GALA)
n/a	O	O	S	Audi Symphony AM/FM stereo with six-disc in-dash CD changer, Radio Data System (RDS) and Graduated Audio Level Adjustment (GALA)

S = standard O = optional n/a = not applicable

A3 2.0 T	A3 2.0 T S line package	A3 2.0 T Premium package	A3 3.2 S line	
				<b>Electronics (cont.)</b>
S	S	S	S	Ten-speaker sound system including subwoofer and center fill speaker
n/a	O	O	S	BOSE® premium ten-speaker sound system with AudioPilot® noise-compensation feature and subwoofer
S	S	S	S	Satellite radio preparation with roof antenna
S	S	S	S	Trip computer
S	S	S	S	Electronic cruise control with coast, resume and acceleration features
S	S	S	S	Electric rear window defogger with automatic timed shut-off feature
S	S	S	S	Radio frequency remote locking system with selective unlock, remote decklid opening, panic function, interior lights and alarm system activation – control integrated in folding ignition key
S	S	S	S	Retained accessory power after key is removed from ignition
				<b>Interior</b>
S	S	S	S	Backlit instrument cluster with automatic brightness control including tachometer, electronic speedometer, odometer, voltmeter, digital clock with date, service interval indicator; fuel and coolant temperature gauges
S	n/a	n/a	n/a	Matte black decorative inlays in center console and door panels
n/a	n/a	S	n/a	Aluminum decorative inlays
n/a	S	n/a	S	Brushed aluminum air vents/door decorative inlays from quattro GmbH
S	S	S	S	Full-length center console with storage area and two built-in cupholders
S	S	S	S	Folding rear center armrest with cupholders
S	S	S	S	Illuminated glove box, rear cargo area, lighter and ashtray
S	S	S	S	Manually adjustable tilt-and-telescoping steering column
S	n/a	n/a	n/a	Three-spoke steering wheel
n/a	S	S	S	Leather-wrapped four-spoke multi-function steering wheel (includes alloy paddle shifters on S tronic models)
S	n/a	n/a	n/a	Cloth seat upholstery
n/a	S	S	S	Leather seating surfaces
n/a	S	n/a	S	Sport seats
S	n/a	n/a	n/a	Manually adjustable driver and front passenger seats
n/a	S	S	S	Twelve-way power driver's seat including four-way power lumbar adjustment and manual passenger seat
S	S	S	S	60/40 split-fold rear seat
n/a	S	S	S	Storage package
S	S	S	S	Fully automatic dual-zone climate control system with sun sensor and activated charcoal filter
S	S	S	S	Power windows with power retention, "one touch up," "one touch down" and pinch protection for all windows
S	S	S	S	"Soft touch" opening for rear decklid
S	S	S	S	Dual front/rear power outlets
S	S	S	S	Cargo cover
n/a	S	S	S	Illumination package
S	S	S	S	Seating capacity: five passengers

A3 2.0 T	A3 2.0 T S line package	A3 2.0 T Premium package	A3 3.2 S line	
				<b>Individual options</b>
n/a	0	0	0	Open sky system
n/a	0	0	0	Bi-xenon headlights with Audi adaptive light and automatic self-leveling
0	0	0	0	Rear side airbags*
n/a	0	0	0	Audi Navigation plus** with six-disc CD changer or iPod® adaptor in glove box
0	0	0	S	SIRIUS® satellite radio
n/a	0	0	0	iPod adaptor in glove box
0	0	0	0	Heated front seats
n/a	n/a	n/a	0	Premium Vienna leather seating
n/a	0	0	0	Phone preparation with Bluetooth® interface¹
n/a	n/a	0	n/a	Dark Brown Walnut wood decorative inlays
n/a	0	0	0	Manual rear door sunshades
n/a	0	n/a	0	18-inch five-spoke quattro GmbH cast alloy wheels with 235/40 summer performance tires¹¹
0	0	0	0	Metallic or pearl effect exterior paint

S = standard 0 = optional n/a = not applicable

A3 2.0 T	A3 2.0 T S line package	A3 2.0 T Premium package	A3 3.2 S line	
n/a	0	0	0	<b>Cold weather package</b>
				Heated front seats
				Heated outside mirrors
				Heated windshield washer nozzles
				Ski sack
n/a	0	0	S	<b>Sound package</b>
				Audi Symphony AM/FM stereo with six-disc in-dash CD changer, cassette player, Radio Data System (RDS) and Graduated Audio Level Adjustment (GALA)
				BOSE premium ten-speaker sound system with AudioPilot noise-compensation feature and subwoofer
				SIRIUS satellite radio
n/a	0	n/a	0	<b>Titanium package</b>
				Piano Black decorative inlays
				Black headliner
				Black grille and exterior trim
				18-inch seven double-spoke Titanium color cast alloy wheels with 225/45 summer performance tires¹¹
n/a	0	0	S	<b>Convenience package</b>
				Light/rain sensor
				Auto-dimming mirror with integrated compass

- A. Light plays a critical role in both passenger ambience as well as safety.
- B. Optional bi-xenon adaptive lighting.
- C. Optional iPod glove-compartment adapter.
- D. Front Sport seats are standard on cars with the S line package.



\*Airbags are supplemental restraints only and will not deploy under all accident circumstances. Always use safety belts and seat children only in the rear, using restraint systems appropriate for their size and age. \*\*The Audi Navigation plus depends upon signals from the worldwide Global Positioning Satellite network. The vehicle's electrical system, and existing wireless and satellite technologies, must be available and operating properly for the system to function. The system is designed to provide you with suggested routes in locating addresses, destinations and other points of interest. Changes in street names, construction zones, traffic flow, points of interest or other road system changes are beyond the control of Audi of America, Inc. Complete, detailed mapping of lanes, roads, streets, toll roads, highways, etc., is not possible, therefore you may encounter discrepancies between the mapping and your actual location. Please rely on your individual judgment in determining whether or not to follow a suggested Audi Navigation plus route. Periodically the mapping is updated and a new DVD will be required in order to maintain the latest navigation information available to us. These will be available for purchase from time to time at additional cost. Consult your dealer or call 1-800-FOR-AUDI for details. ¹Your Audi vehicle is equipped with a phone preparation utilizing Bluetooth interface to enable hands-free functionality (compatible mobile phones sold separately). You will need a Bluetooth-enabled mobile phone in order to utilize this function. Not all Bluetooth-enabled mobile phone models are compatible with Audi's phone preparation. Visit our Web site, audiusa.com or contact your local Audi dealer for the latest listing of compatible phones. Audi recommends use of the Audi phone cradle (sold separately) with your mobile phone while operating this vehicle. ¹¹These tires are designed for optimum performance and handling in warm climates. They are not suitable for cold, snowy or icy weather conditions. If you drive under those circumstances, you should equip your vehicle with all-season or winter tires, which offer better traction under those conditions. We suggest you use the recommended winter or all-season tires specified for your car or its equivalent. These summer performance tires also have a lower aspect ratio that aids performance and handling; however, in order to avoid tire, rim or vehicle damage, it is important that the inflation pressure is regularly checked and maintained at recommended levels. Please also remember in making your selection that, while these tires deliver responsive handling, they may ride less comfortably and make more noise than other choices. Finally, these tires may wear more quickly than other choices. For more information on all of these topics, please consult the owner's manual, your local dealer or call 1-800-FOR-AUDI.

**Color Choices**

Exterior Colors	Cloth Seating	Leather Seating Surfaces	Premium Leather Seating**
Brilliant Black	Black, Light Gray, Beige	Black, Light Gray, Beige	Black, Light Gray, Beige
Brilliant Red	Black	Black, Beige	Black, Beige
Ocean Blue pearl effect	Light Gray, Beige	Light Gray, Beige	Light Gray, Beige
Ice Silver metallic	Black, Light Gray	Black, Light Gray	Black, Light Gray
Lava Gray pearl effect	Black, Light Gray	Black, Light Gray, Beige	Black, Light Gray, Beige
Ibis White*	Black, Beige	Black, Beige	Black, Beige
Deep Sea Blue pearl effect*	Black, Light Gray, Beige	Black, Light Gray, Beige	Black, Light Gray, Beige
Misano Red pearl effect**	n/a	Black, Light Gray, Beige	Black, Beige

\*Sold order option only. Premium charge applies. \*\*Available with S line package only.  
n/a = not available

Seating	Upper Dashboard	Carpets	Headliner
Black	Black/Black	Black	Light Gray
Light Gray	Black/Light Gray	Light Gray	Light Gray
Beige	Black/Light Beige	Light Beige	Light Beige

**Interior Colors/Trim**

**Exterior Colors**

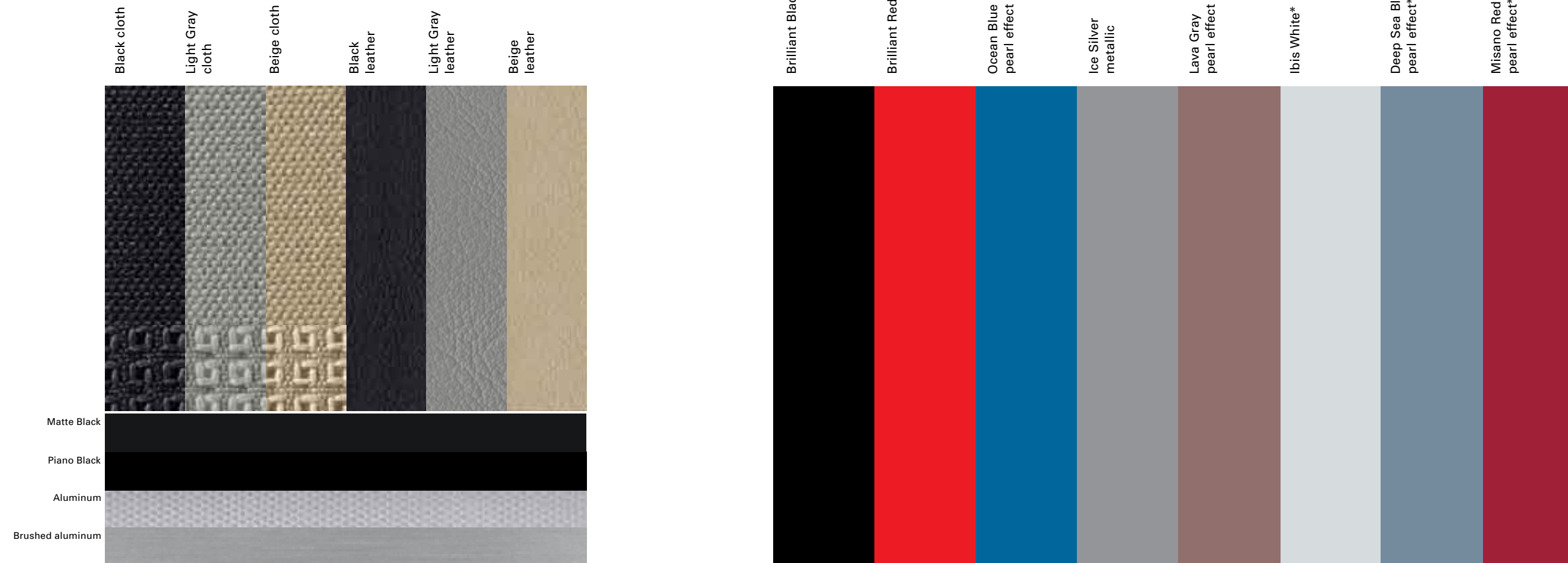

\*Sold order option only. Premium charge applies.  
\*\*Available with S line package only.

“The only innovations that interest me are the ones that lead to greater strength and quality.” – August Horch, Founder – Horch/Audi



A man of strong convictions, August Horch left a comfortable position when it became clear that the only way to see if his innovations would work was to start his own car company. First Horch. And then Audi. Two of the four companies symbolized by interlocking rings. His belief in advanced technology, responsive performance, inspired design and consummate safety led to quattro, the ASF<sup>®</sup> FSI, TDI as well as hundreds of checkered flags from Le Mans to Pikes Peak. From the iconic TT to the intuitive MMI operating system to zinc galvanizing to high safety scores across the board, a zeal to test limits and challenge convention. You can see it in the all-new R8. Feel it in every car with quattro. Sense it in the stunning all-new S5. Hear it every time you close a door.

From humble origins in Germany more than 100 years ago to cars sold in more than 100 markets around the globe, it's been quite a journey. The singular vision of one man now shared by millions. And growing by leaps and bounds. All because of a conviction that when it comes to design, performance, technology and safety, there are no shortcuts. **TRUTH IN ENGINEERING.**

audiusa.com

Note: A word about this brochure. Audi of America, Inc. believes the specifications in this brochure to be correct at the time of printing. However, specifications, standard equipment, options and colors are subject to change without notice. Some equipment may be unavailable when your vehicle is built. Please ask your dealer for advice concerning current availability of standard and optional equipment and verify that your vehicle will include the equipment you ordered. Vehicles in this brochure are shown with optional equipment. See your dealer for complete details on the limited warranty, Audi 24-hour Roadside Assistance (Coverage provided by Road America) and 12-year limited warranty against corrosion perforation. Tires supplied by various manufacturers. "TRUTH IN ENGINEERING" is a trademark of Audi of America, Inc. "Audi," "quattro," "A3," "A6," "A8," "TT," "R8," "S5," "ASF," "R10 TDI," "FSI," "MMI," "Sideguard," the four rings and Audi emblems are registered trademarks and "S tronic" is a trademark of AUDI AG. "BOSE" and "AudioPilot" are registered trademarks of the Bose Corporation. "Bluetooth" is a registered trademark of Bluetooth SIG. "ESP" is a registered trademark of DaimlerChrysler AG. "SIRIUS" is a registered trademark of SIRIUS Satellite Radio, Inc. "iPod" is a registered trademark of Apple Inc.

A word about updated service information. Audi regularly sends its dealers useful service information about its products. Audi monitors product performance in the field, then prepares bulletins to better service its products and help avoid costly repairs. To order, see your local Audi dealer.

©2007 Audi of America, Inc.

Printed in U.S.A.

C-A3-08-006US