

Packard "thirty" 1908

E. Ralph Estep,
Packard Motor Car Company

PACKARD

“THIRTY”

1 9 0 8

**A MOTOR CAR
CATALOGUE**

**PACKARD MOTOR
CAR COMPANY
DETROIT, MICHIGAN**

“Ask the man who owns one.”

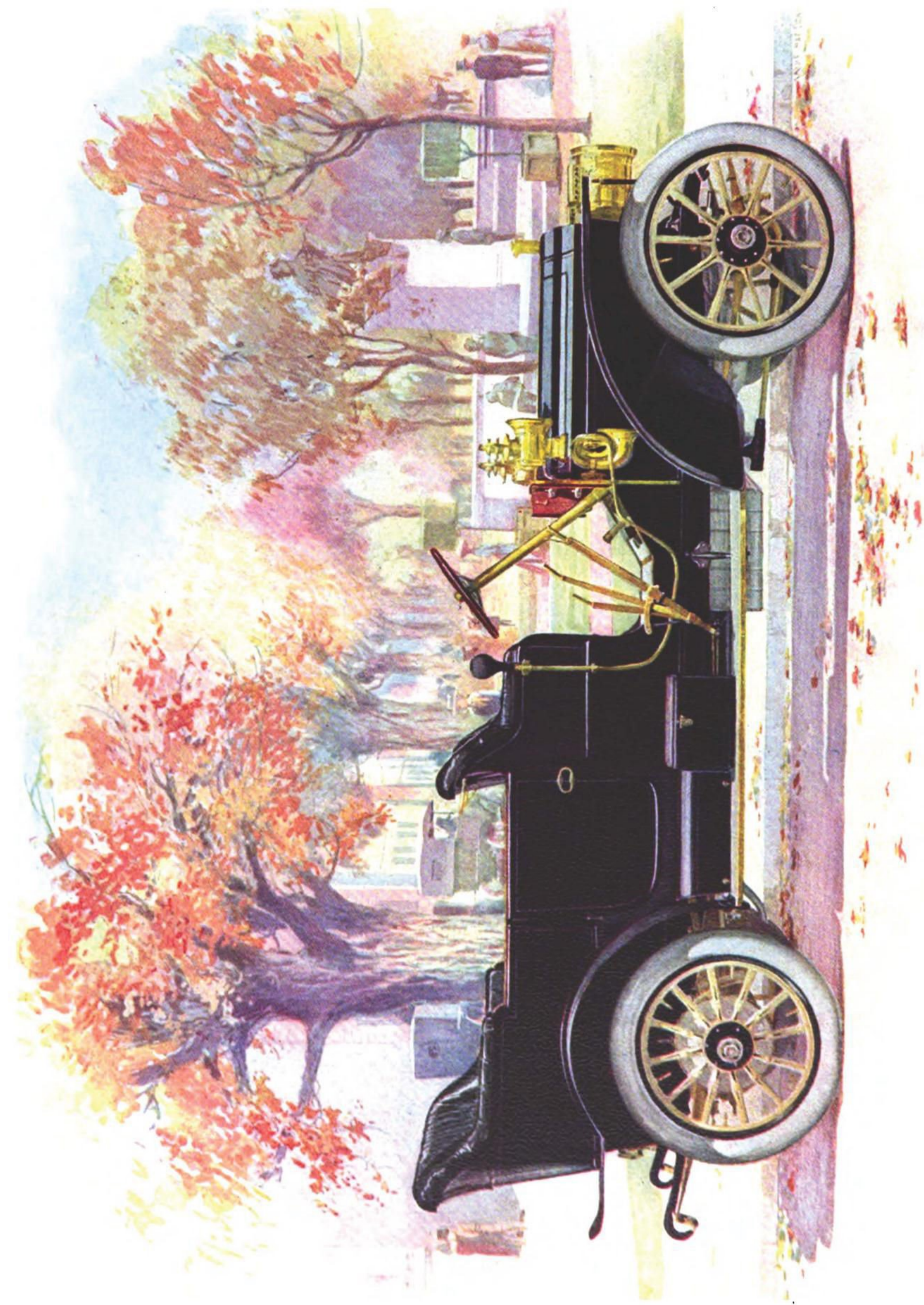

PACKARD

THE LONGEST SERVICE

COMPANY IN THE WORLD

CONTINUED FOR THE WORLD

is the entire Packard line of automobiles. This latest model represents the highest development from it. Packard's record of progressive advancement in car-making, the car that is complete and scrupulous refinement of detail. It is so well adapted to the work which has been allotted to it.

Packard "Thirty" has the car in all manner of service, equipment and other features, the perfection of the single model, satisfactory in detail, it fills every need of the present. "Thirty" is intended as a vehicle for the widely varying demand for a new class of place of horse-drawn vehicles.

Being the development of a new car "Thirty" has these advantages for the road. Year after year the best of the world, and has seen the scientific progress satisfied to rest on the experience of each season has sought experience of the world. Last year in the type of car for customers began, there was a year many more. Packard's

Packard "Thirty"
1908 Touring Car

PACKARD "THIRTY"—1908

THE long-established and well-known policy of the Packard Motor Car Company to make motor cars of but one model each year is continued for the season of 1908. The Packard car which is the object of the entire Packard endeavor is a new "Thirty." Like its antecedents, this latest model represents an evolution of preceding practice, rather than a departure from it. Packard "Thirty" is a type; it is the result of ten years of progressive adherence to a single purpose. In its design and general make-up the car shows improvement dictated by experience, and a thorough and scrupulous refinement of detail in keeping with the spirit of its development. It is essentially a Packard. The well-known and proven features upon which has been builded the Packard success are its features.

Packard "Thirty" has the qualities which make it a successful country car in all manner of service, and is also, by its stylishness, luxurious appointment and other features, thoroughly a town car. In the different adaptations of the single model, such as touring car, limousine, runabout, and landaulet, it fills every need of the purchaser of a high-class motor car. Packard "Thirty" is intended as a vehicle of such great utility as to meet the more widely varying demand that has arisen since motor cars have begun to take the place of horse-drawn vehicles.

Being the development of an arduous decade in motor car building, Packard "Thirty" has those strictly motor car abilities which insure its success on the road. Year after year the Packard has toured to the far corners of the world, and has seen the strenuous service which either makes or breaks. Not satisfied to rest on the experience of cars in owners' use, the Packard company each season has sought experience of its own. It has been rigorous testing, indeed. Last year in the tryout of experimental cars before the delivery of cars to customers began, there was rolled up a testing record of 50,000 miles—this year many more. Banged into every bump on the long overland trips; rushed



1908 Touring Car
Packard "Thirty"

Packard "Thirty"—1908

night and day over snow-covered or water-slippery highways; pushed unhesitatingly along the tortuous roads of mountain country, or forced through miles of western sand, the experimental cars have proven Packard "Thirty," as a touring car, even to the extreme meaning of the word.

Added to the sturdy qualities of Packard "Thirty" are those of refinement and elegance of a degree ordinarily credited only to vehicles of gentler growth than ones noted for their highway prowess. Just as a Packard "Thirty" touring car or runabout is capable on the rough American road, so it is modish, comfortable, and elegant on the streets of the town. Packard "Thirty," as a limousine or as a landaulet, is a superlative creation of the body-builder's art.

There is no one feature of a Packard "Thirty" to give it mechanical distinction. By its entirety is Packard "Thirty" known throughout Autoland, wherein a by-word has been made of the Packard slogan: "Ask the man who owns one."



THE PACKARD FACTORY

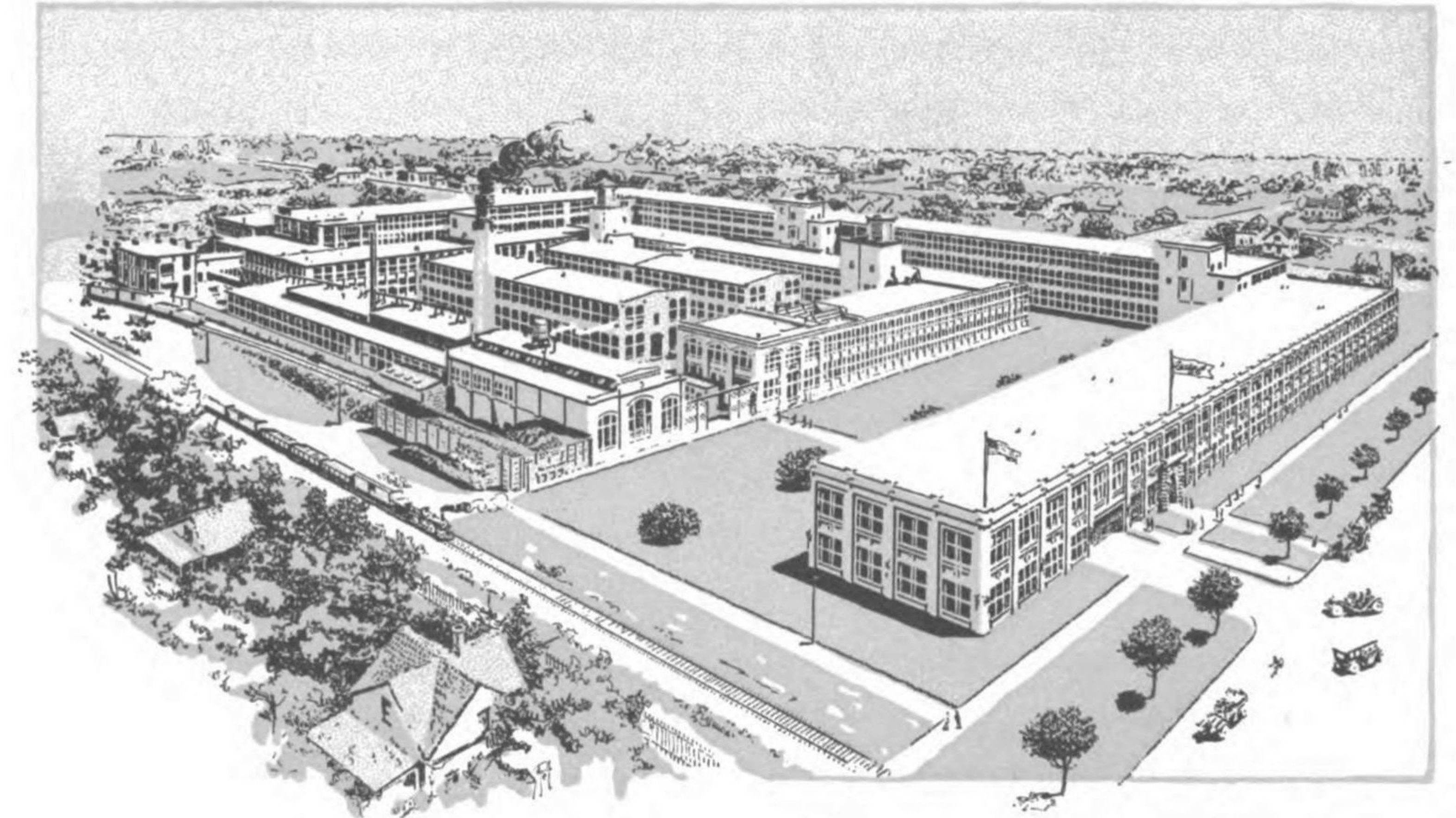

THE factory of the Packard Motor Car Company, at Detroit, Michigan, is the largest manufactory in the world devoted entirely and exclusively to the manufacture of motor cars of one model. It contains 430,000 square feet of floor space—exactly ten acres. In construction and equipment it is all modern and model. The buildings are of reinforced concrete and brick, and are laid out in quadrangular form around the original square of 100,000 square feet, now more than quadrupled.

In equipment and organization the factory shows the same progressive spirit that has characterized its growth in size. More wonderful than its

The Packard Factory

enlargement, however, has been its steady, consistent development on the line of the original Packard policy. Ten years ago, in the corner of an electrical manufactory at Warren, Ohio, the dominant purpose of Packard achievement embryonically was established. A motor car business, centralized on one model, and that model a capable touring car, was started. The business grew, the car grew, and the whole organization grew in spirit, in capability, and in effect.

When the Packard Motor Car Company built a new plant at Detroit, the original intent was firmly kept. Magnitude of factory, of equipment and of production meant simply magnitude of the governing motive. Hence the picture of ten acres of manufacturing floor space, of hundreds of busy machines and of thousands of men all devoted to the single, unalloyed aim of creating Packard "Thirty" motor cars.

No less striking than the centering of such a great organization on one object is the way in which it is done. There is no confusion in the industrial drama here enacted. Departments are many and large, but growth has not disturbed their interwoven system, by which they give unto one another and, together, turn raw material into finished motor cars. Noticeable throughout the factory in the making of Packard "Thirties" is the fact that the organization does not take one whit from excellence to give to mere productive power. All work is of a certain class. No demand of quantity can rob work of required quality. Each piece, each operation, each process, is carefully and thoroughly done to the Packard standard. So rigorous is the system in its exaction upon detail that it is impossible to erect false standards.

The factory is a unit. It encompasses everything in the building of Packard cars, from their exclusive design and the purchase of materials to the distribution of cars by the sales department. In each converging channel of Packard effort there is uppermost and compelling the same universal object. Packard "Thirty" is the motive and is also the result.

Packard
"Thirty"
1908

Illustrated

PACKARD "THIRTY"—ILLUSTRATED

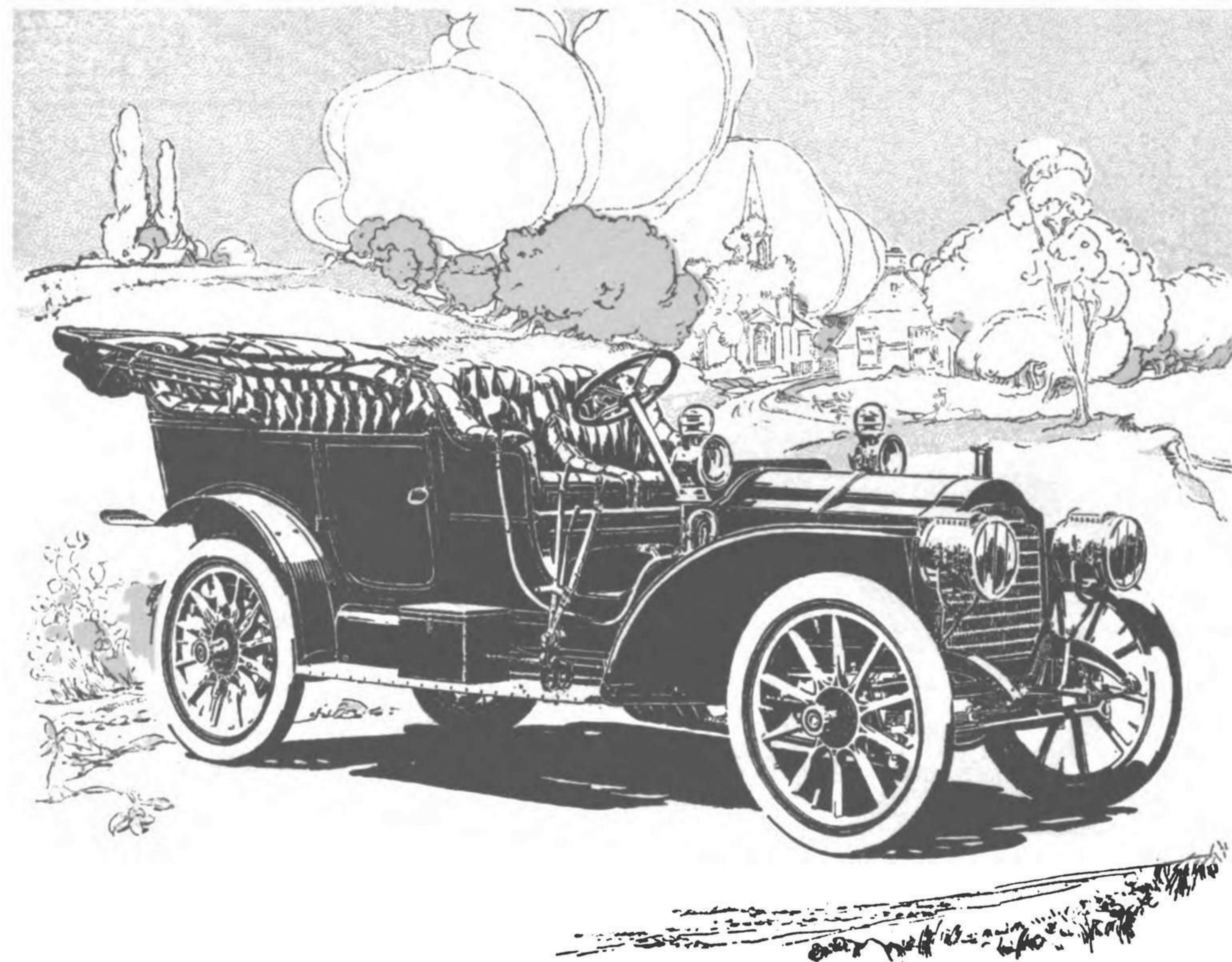

PACKARD "Thirty" is primarily a touring car, equally well suited to severe cross-country touring and town service. The price, in standard finish and equipment, is \$4,200, f. o. b. Detroit. Packard Special extension cape cart tops are exclusive in design and material. They are made over jigs and are interchangeable. The side bows are curved to obviate projecting side irons. The rear brackets afford two positions of the top when folded. The price of the top, with side curtains, is \$150.

Packard "Thirty"—Illustrated

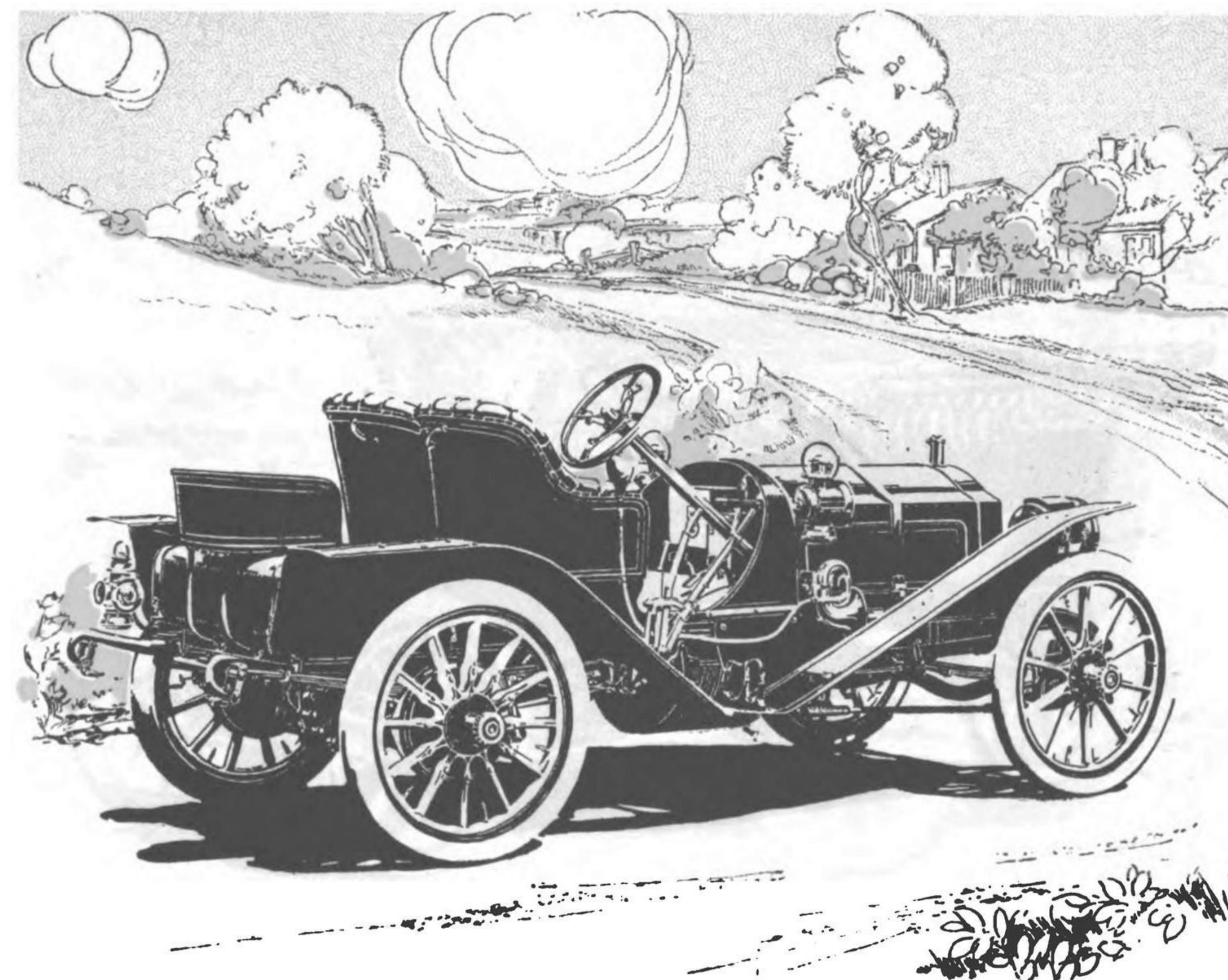

HERE is no motor car more jaunty than the Packard "Thirty" runabout. Swagger as it is for town use, it has the tried and proven characteristics which make it especially capable in arduous overland touring. While it is a Packard "Thirty" throughout, it is strictly a runabout in proportions, weight distribution, wheel base, and other features wherein runabout requirements differ from those of a touring car. The price, in standard finish and equipment, is \$4,200, f. o. b. Detroit.

Packard "Thirty"—Illustrated

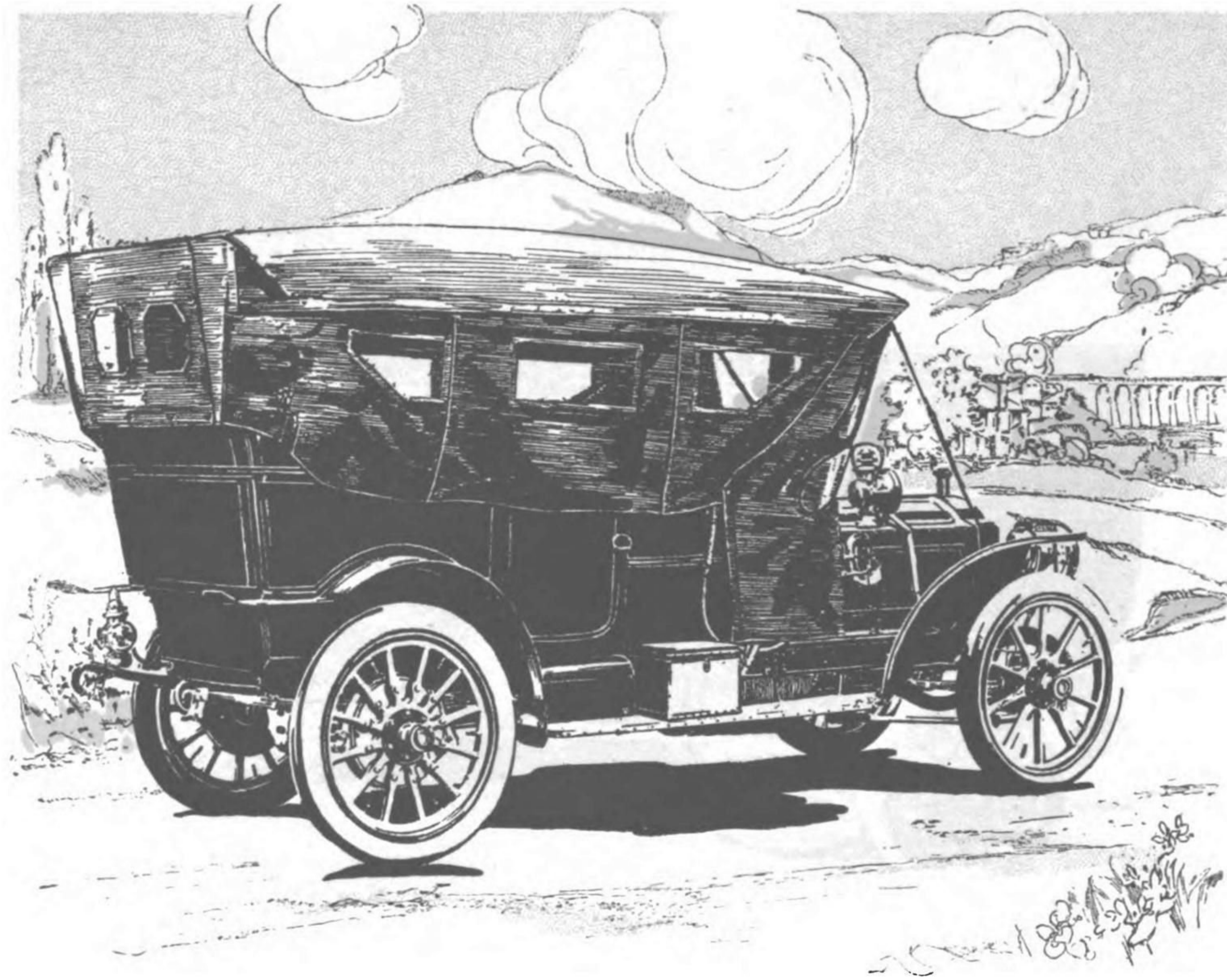

WITH side curtains, roll storm front and corner curtains, all celluloid-lighted, the Packard Special extension cape cart top prevails over storm and cold. The storm curtain rolls snugly underneath the top, and so practically is unnoticeable when not in use, either with the top up or folded. When desired it may be dropped instantly. The corner curtains make the protection absolute against wind or rain. The price of the top, including storm front and corner curtains, is \$180.

Packard "Thirty"—Illustrated

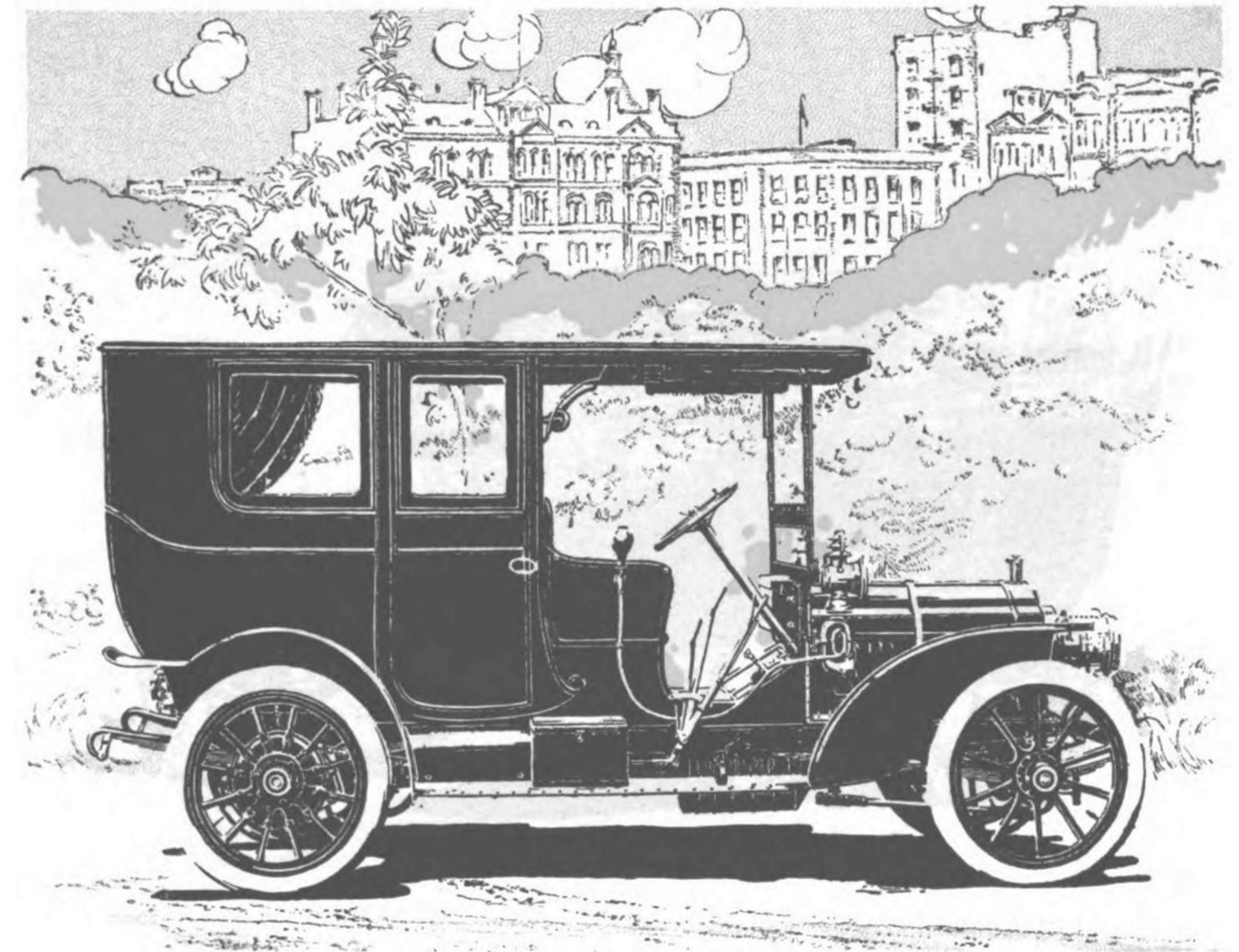

ENCLOSED bodies for Packard motor cars are made in one of the largest body-making institutions in the world. It is a complete factory within a factory, especially and exclusively organized and equipped for the production of Packard enclosed bodies. These are not only modish in general design and up-to-date, but have all the latest features of comfort and convenience. They are made to meet the requirements of even the most fastidious. The price of the limousine body is \$1,750.

Packard "Thirty"—Illustrated

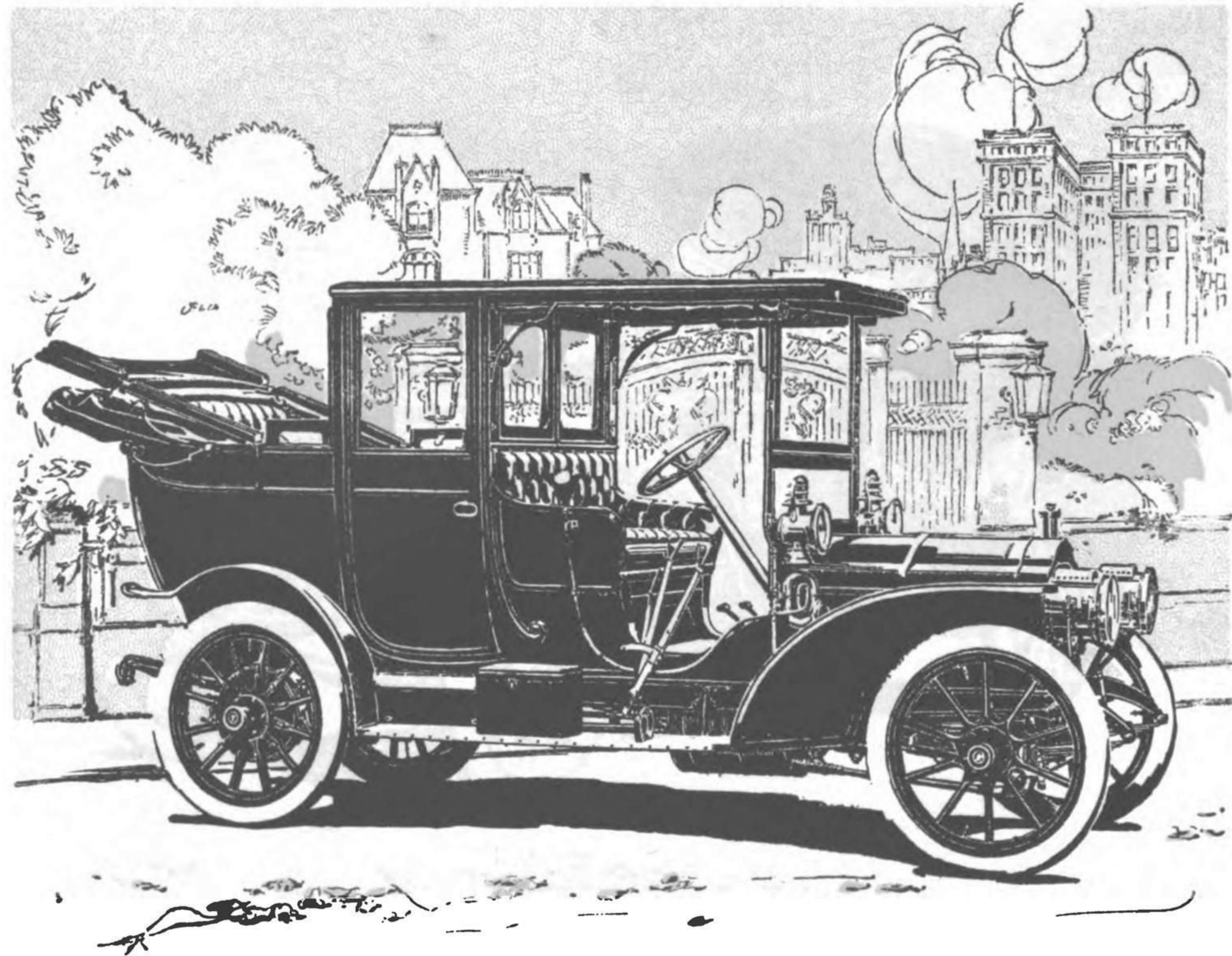

As a landaulet, Packard "Thirty" is presented in a form most suitable for conventional city motoring, especially that of women who desire a stylish, graceful carriage which can be used equally well both as a closed and as an open vehicle. The landaulet is the companion product of the limousine and has the same refinement of design and construction, the same luxurious appointment, and the same elegance of finish. The price of the landaulet body is \$1,850.

Packard "Thirty"—Illustrated

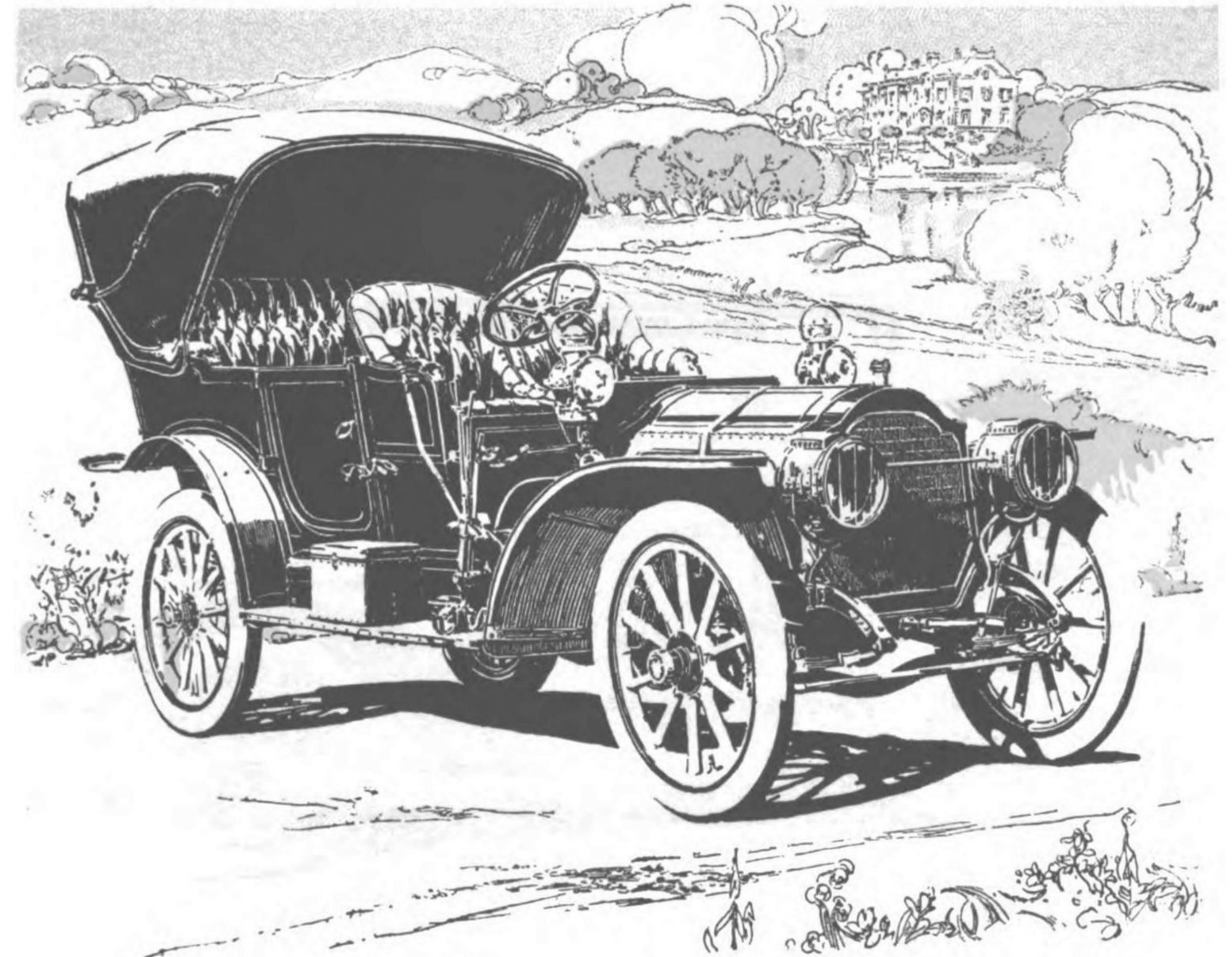

SPECIAL Victoria top is made for the Packard "Thirty" touring car, and also for the runabout. The latter adaptation is a particularly fitting and pleasing one. The price of the Victoria top is \$325 for the touring car and \$150 for the runabout. Canopy tops, either with or without back glass, and equipped with folding glass wind shields, are also furnished. The price of the glass-back canopy top is \$470. A special folding glass wind shield for use with the cape cart top may also be obtained.

A PAGE OF PRICES

Packard "Thirty" Touring Car, in Standard Finish and Equipment	\$4,200.00
Packard "Thirty" Runabout, in Standard Finish and Equipment	4,200.00
Packard "Thirty" Touring Car Chassis, in Priming Coat and Standard Equipment	3,800.00
Limousine Body, Standard Finish and Equipment	1,750.00
Landaulet Body, Standard Finish and Equipment	1,850.00
Attaching either Landaulet or Limousine to Chassis	50.00
Packard "Thirty" Runabout Chassis, in Priming Coat and Standard Equipment	4,000.00
Runabout Body, in Standard Equipment and Finish	400.00
Touring Car Body, in Standard Equipment and Finish	800.00
Packard Special Extension Cape Cart Top with Side Curtains, attached	150.00
Packard Special Storm Front, with Celluloid Front and Corner Lights	30.00
Standard Glass-Back Canopy Top, attached	470.00
Standard Victoria Top, attached	325.00
Packard Special Victoria Runabout Top, attached	150.00
Packard Adjustable Glass Wind Shield, attached	70.00
Special Colors, Body and Gear	50.00

Packard dealers will furnish prices on all other special features and equipment. All prices f. o. b. factory, Detroit



PACKARD "THIRTY" DESCRIBED

THE difference between Packard "Thirty" for 1908 and preceding models of the Packard motor car is the difference of development. The changes show growth. There are improvements in detail, dictated by experience. Throughout the car there has been a consistent endeavor to refine and simplify, even to the most trivial considerations. The broad principle of design is the same.

The four-cylinder, vertical, water-cooled motor is of 5-inch bore by 5½-inch stroke. The European rating is 30 horsepower at 650 revolutions per minute. The horsepower by the American system exceeds this figure.

The cylinders are cast in pairs, with water jackets and valve chambers integral. The castings for cylinders, exhaust manifolds, pistons, and piston-ring blanks are made in France, from a gray iron especially adapted to the construction of such parts. The pistons are ground and are fitted with four ground rings. The cylinders, pistons, and rings are "lapped" together with a suitable polishing agent which gives them a highly-finished surface and smoothly-working fit.

The crank shaft is cut from a solid billet of hammer-forged, high-carbon, open-hearth steel. It is oil-tempered; all bearing surfaces are ground, and the entire shaft is machine finished. It runs on three liberal bearings and is bushed with Parsons white bronze. The connecting rods are drop forgings. The crank-pin bearings are bushed with Parsons white bronze, and the piston pins with hard bearing bronze.

The inlet and exhaust valves are on opposite sides of the cylinders; they are all mechanically operated and interchangeable. The cam shafts are enclosed within the motor crank case; are fully protected from dirt, and are certain of ample lubrication. The cam shaft drive gears, as well as those of the magneto and water pump, are contained in a separate, but integrally-cast, oil-tight extension of the crank case.

The crank case is cast of a special aluminum alloy in three horizontal sections. The uppermost section forms the engine base and is supported directly

Packard "Thirty" Described

on the side members of the main frame of the car. On each side, between the transverse supporting arms, is a horizontal, integrally-cast web which entirely encloses the space between the motor and frame, affording complete protection to the motor, magneto, and other parts above it. The crank shaft bearings are held between the uppermost and middle sections, while the bottom section is simply an oil well, easily removable for inspection or adjustment of the connecting rods, cam shafts, etc., without disturbing the crank shaft bearings. The crank case is divided into front and rear compartments by a transverse central partition which supports the middle crank shaft bearing.

The carburetor is of special Packard design. It is of the float nozzle type with auxiliary air inlet. The mixing chamber is cylindrical and vertical, containing in its lower portion the aspirating nozzle butterfly throttle, and above this a poppet valve unsecured to the inlet coil spring. It governs the quantity but not the mixture of the

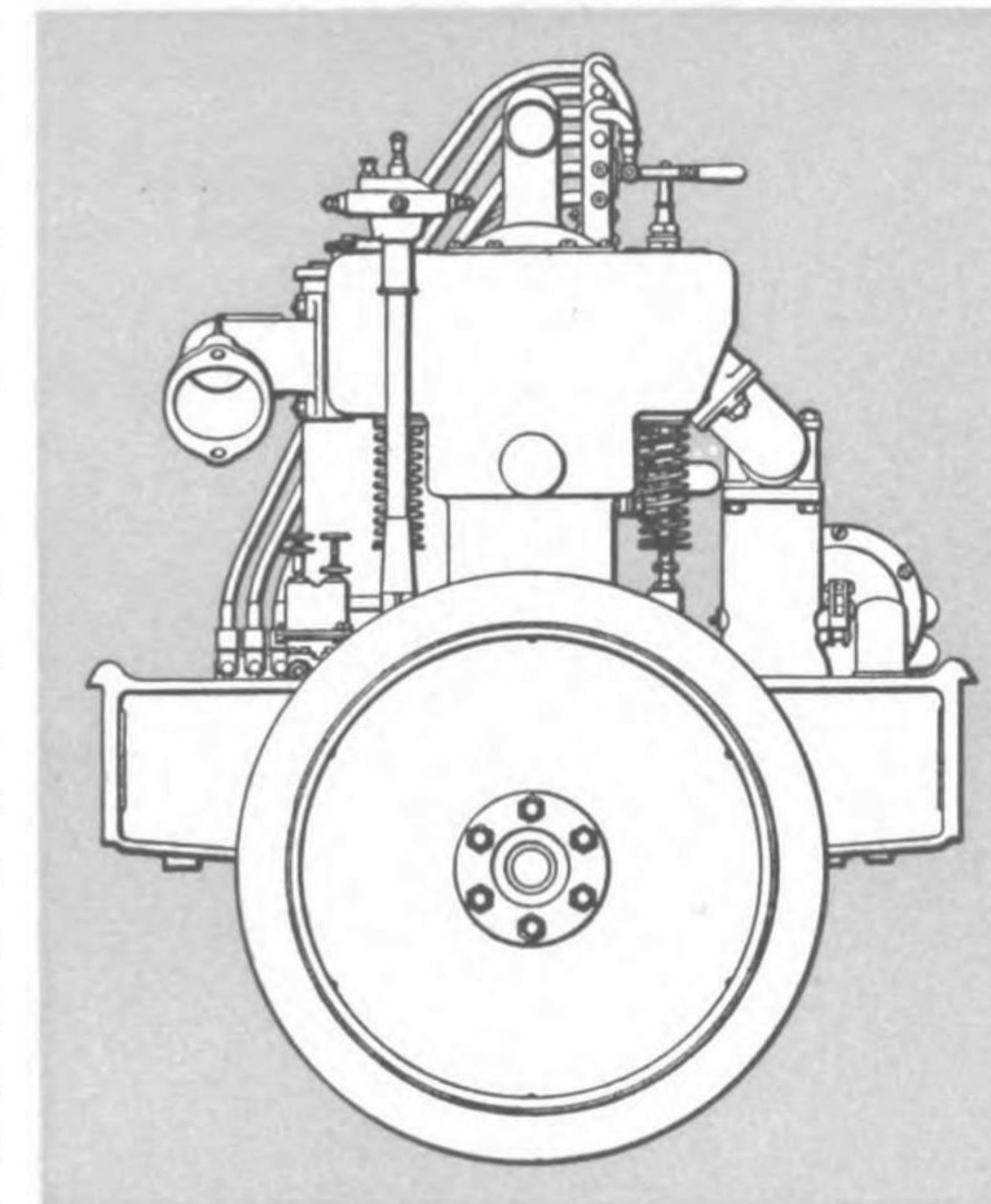

Rear Elevation of Packard "Thirty" Motor

the mixture of the fuel and air. Its tension, to suit different atmospheric conditions, may be regulated by a sliding wedge which is actuated by a small lever on the dashboard of the car. The carburetor is kept at a uniform temperature by warm water circulating through a jacket surrounding the mixing chamber. This circulation is incorporated in the general water-cooling system of the motor. The fuel supply is taken by gravity from a copper

retor is of special and construction. feed, aspirating-automatic auxiliary air inlet. The mixing chamber is cylindrical and vertical, lower portion the aspirating nozzle butterfly throttle, and above this a poppet valve unsecured to the inlet coil spring. It governs the quantity but not the mixture of the fuel and air. Its tension, to suit different atmospheric conditions, may be regulated by a sliding wedge which is actuated by a small lever on the dashboard of the car. The carburetor is kept at a uniform temperature by warm water circulating through a jacket surrounding the mixing chamber. This circulation is incorporated in the general water-cooling system of the motor. The fuel supply is taken by gravity from a copper

Packard "Thirty" Described

gasoline tank under the front seat, with a capacity of twenty-one gallons. The water circulation for cooling the motor is positive by means of a gear-driven gear pump. The radiator is of the ribbed tubular style, combined with the tank. Forced draft to increase the cooling efficiency is obtained by a belt-driven fan. It is adjustably mounted on a bracket on the front of the motor base, so that the tension of the belt may be regulated. The fan runs on imported annular ball bearings. The water-circulating system has a capacity of six gallons. The water, oil, and gasoline tank caps are secured by bayonet locks instead of by screw threads.

Ignition is by jump spark. The current is obtained from an imported Eisemann low-tension magneto. This is mounted on the motor bed on the left side and is direct gear-driven by enclosed gears. A Fulmen imported storage battery, used primarily for starting the motor from the seat, is always in reserve. There is a transformer coil for the magneto current and a vibrator coil for the battery current. The two coils, with a single hand-switch for both magneto and battery between them, are arranged as a unit in a box on the dash. The switch is provided with a lock.

The commutator for the battery primary current is on a vertical shaft at the rear of the motor and is driven from the cam shaft by enclosed bevel gears. There is but one set of secondary or high-tension wires, the same spark plugs being used for both magneto and battery systems. The plugs are connected

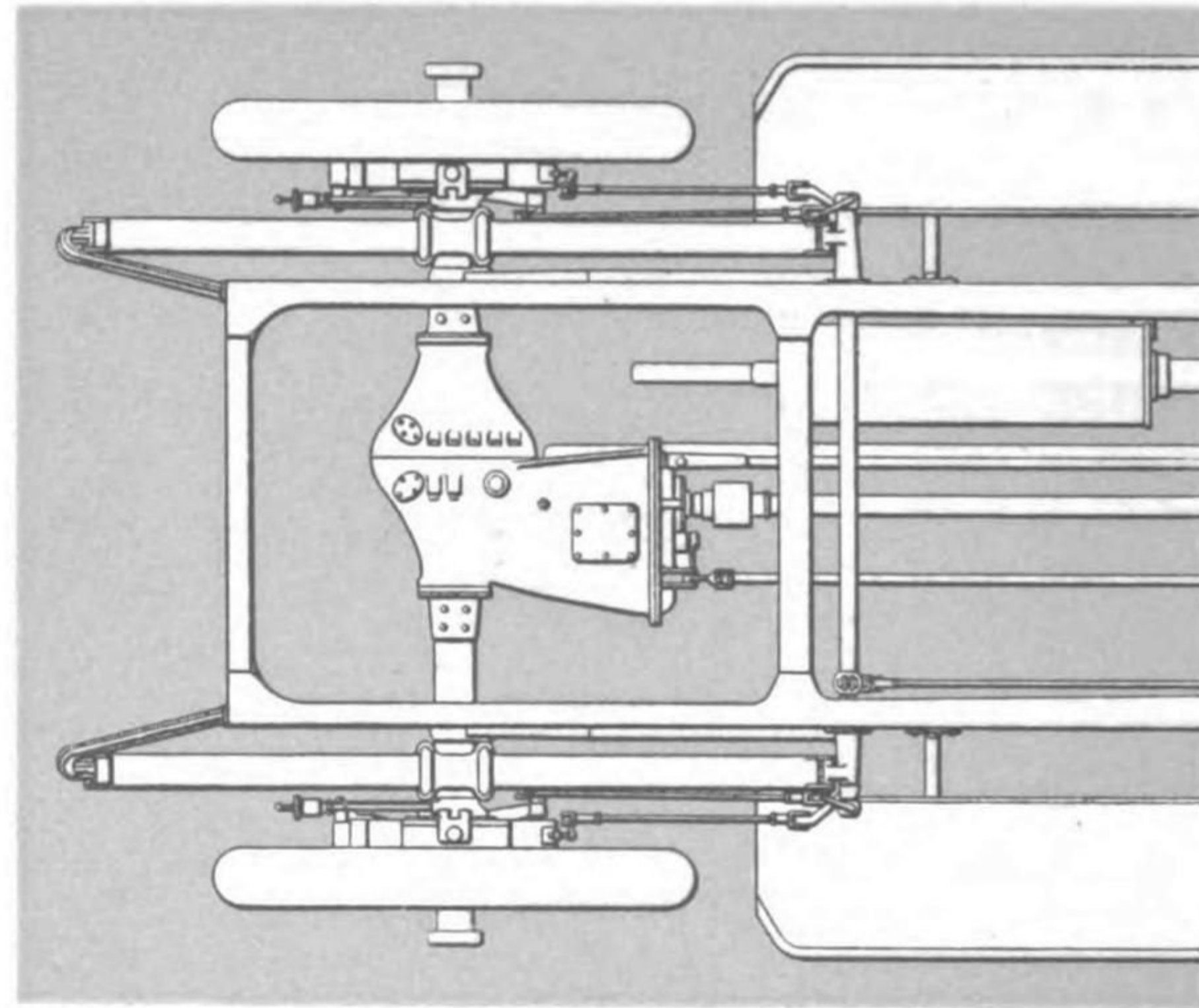

Plan View of the Complete

Packard "Thirty" Described

with the secondary wires by knife switches. These permit the instant disconnection of any plug. The compression relief cocks are of improved design.

The lubrication of the motor is by splash from the crank case to the cylinders and engine bearings. Oil is pumped separately to the front and rear compartments of the crank case. The transverse partition maintains an independent level of oil below each pair of cylinders, regardless of the inclination of the car on grades. The double-plunger pump is accessibly located at the left of the motor and is driven by a worm on the exhaust valve cam shaft. It takes oil from a vertical copper reservoir close to and between the pairs of cylinders, this location insuring that the oil will be warmed and thus kept in a fluid, easily flowing condition, even in coldest weather. The oil, on its way to the crank case, passes through two drip sight-feeds on the dashboard. The crank case drain cocks are provided with new anti-clogging devices.

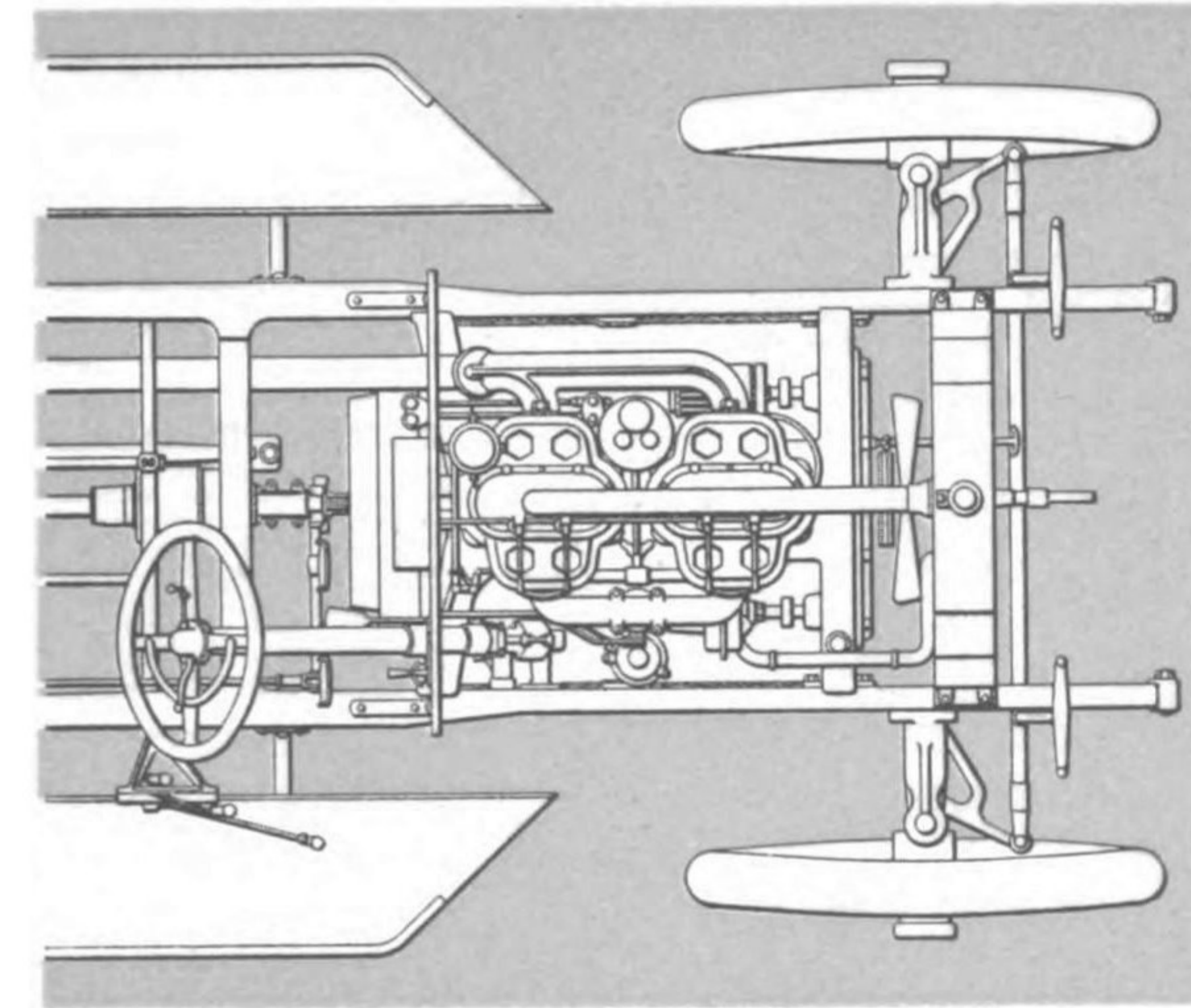

Chassis of Packard "Thirty"

The engine speed is under the control of a hydraulic governor. This is a diaphragm apparatus incorporated in the water-circulating system. It acts directly on the butterfly throttle above the carburetor, and tends to prevent the motor from racing when the car is standing with the motor running idly. Its limitations are adjustable and, by a pedal, it may be cut out of action for instantaneous acceleration. The throttle is also under the control of the hand lever on the steering wheel, while another manual lever on the wheel advances or retards the spark.

Packard "Thirty" Described

The Packard type internal expanding clutch is, of course, retained, with improved construction to insure gradual engagement. The expanding ring within the flywheel inner rim is actuated by a screw-and-nut device and is provided with means of easy adjustment.

The propeller shaft connecting the clutch with the transmission gear has, at its forward end, a newly-designed universal joint of the yoke type, especially suited to the greater angularity existing at this point than at the rear, where there is a roller universal joint. Both joints are effectively encased. The speed-changing set, bevel gear, final drive, and differential gears are all contained within a rigid aluminum housing, thus forming a unit. In the new

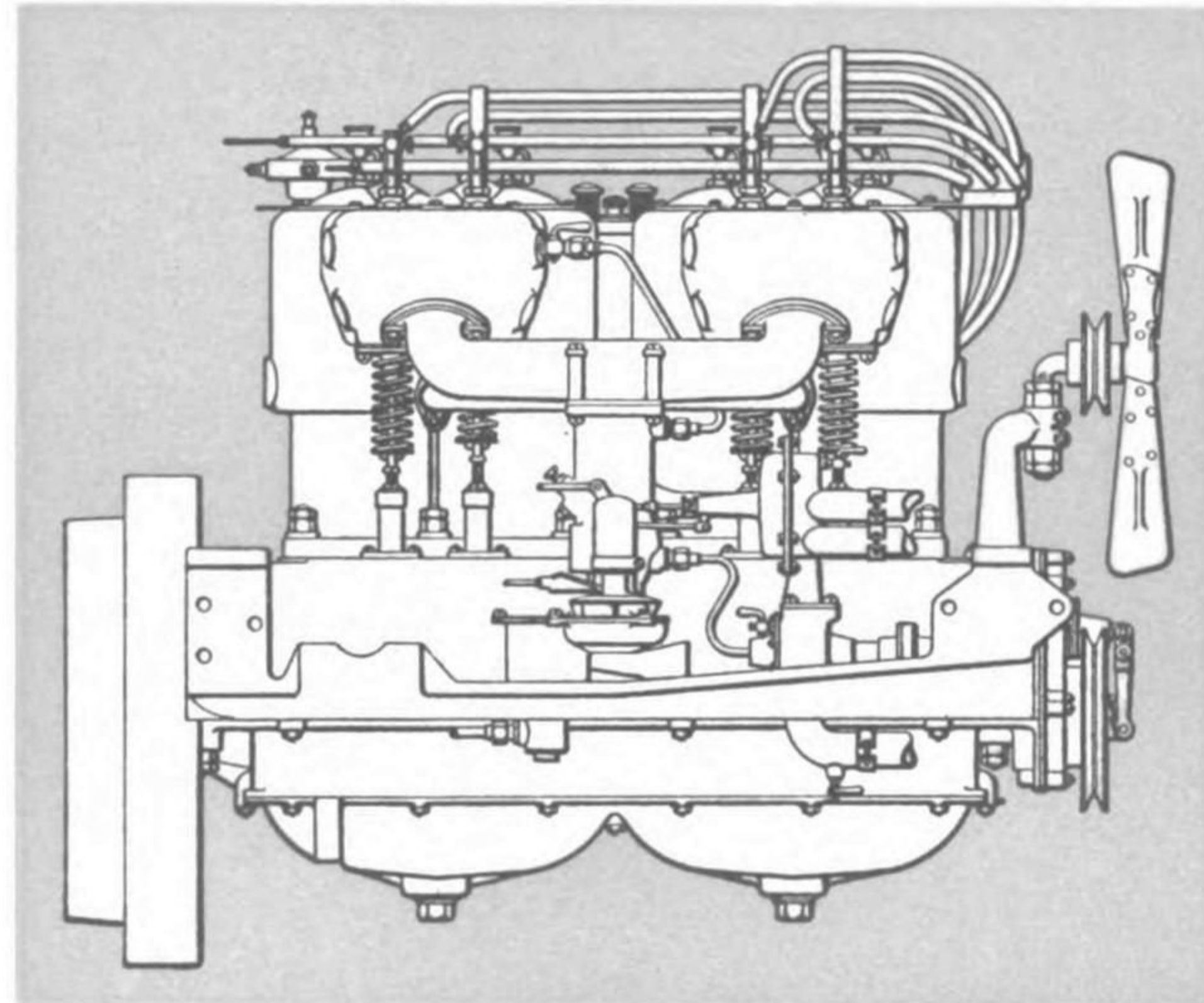

Inlet Side of Packard "Thirty" Motor

design the casting is internally ribbed, while the outside is smooth. There are covered inspection holes. The differential gear unit is supported on its own bearings. The live axle may be withdrawn without disturbing the gears. Three forward speeds and a reverse are obtained by the sliding gears of the speed-changing set. The third speed forward is by direct drive. That the shifting of the sliding gears for different speeds may be easily and progressively accomplished, the actuating slide rod is annularly grooved to correspond with spring-retained spacing dogs which determine the respective correct positions of gear engagement. The reverse is obtained by a separate lever. All gears in the transmission, final drive, and differential, as well as the rear axle, run on imported annular ball bearings.

design the casting is internally ribbed, while the outside is smooth. There are covered inspection holes. The differential gear unit is supported on its own bearings. The live axle may be withdrawn without disturbing the gears. Three forward speeds and a reverse are obtained by the sliding gears of the speed-changing set. The third speed forward is by direct drive. That the shifting of the sliding gears for different speeds may be easily

Packard "Thirty" Described

There are four brakes. On each rear wheel there is a brake drum, upon which act both the internal-expanding and the external-contracting brakes. The external brakes are operated by a pedal for regular use, while a side hand lever controls the internal or emergency brakes. A drum disc entirely encloses and protects each internal brake. This system of brakes obviates the use of braking power through the transmission gear, and insures quick, positive application of both foot and hand brakes. A new pedal design obtains a much shorter travel, and also decreases the length of the lever slots in the footboard.

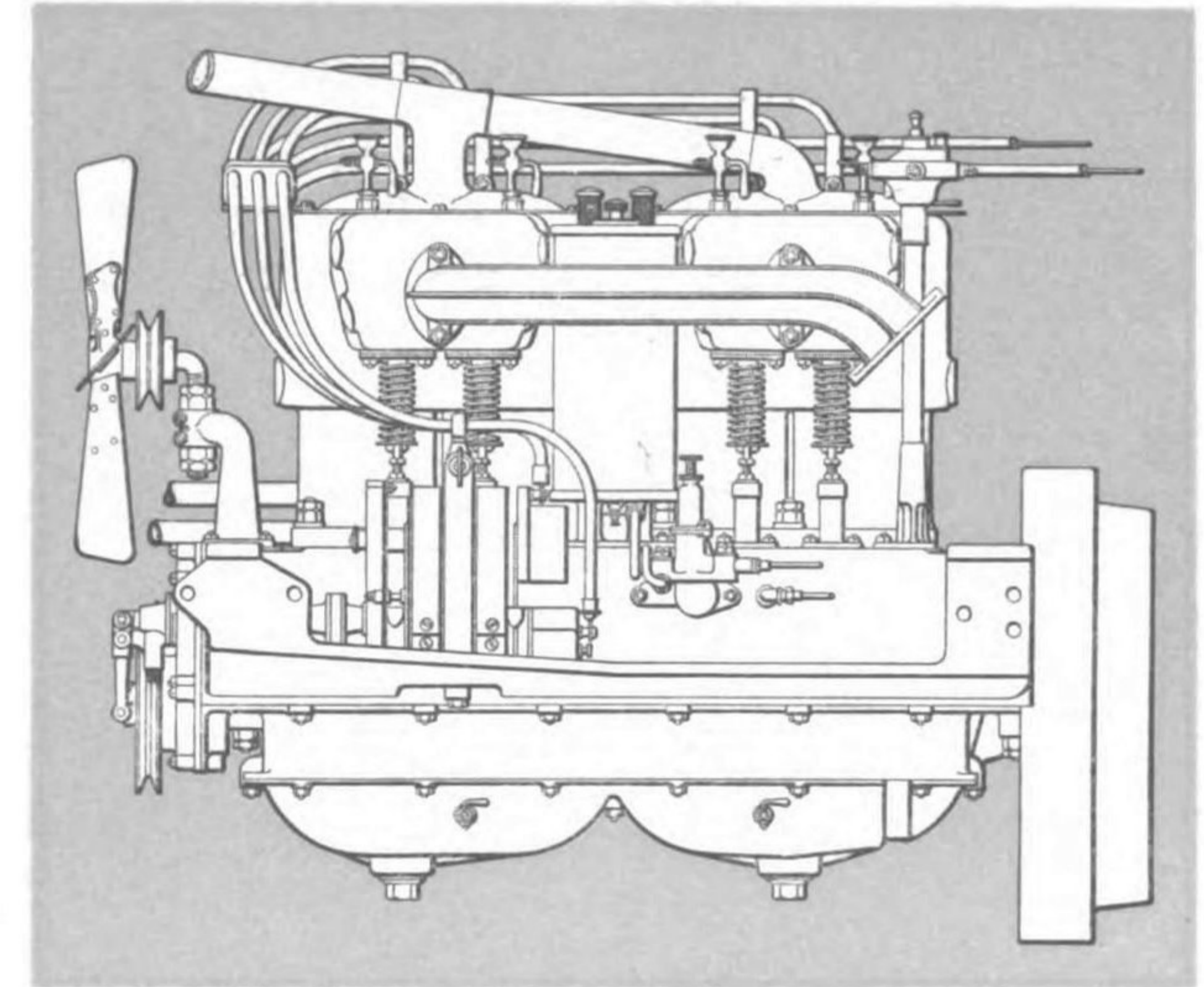

Exhaust Side of Packard "Thirty" Motor

Steering is by the usual hand wheel, through a worm-and-sector gear. The worm and sector are forged integrally with their respective shafts. The steering wheel has been increased in diameter, and greater rigidity has been obtained by a larger steering column. The steering spindles and jaw type yokes are drop forgings. To obtain greatest ease of steering the length of the knuckle spindles has been increased. Imported ball thrust bearings are used in the knuckles. All steering connections have provision for lubrication, and the steering rod universal joints are well encased.

The running gear frame is of channel-section pressed steel, arched above the rear axle to provide increased spring action without raising the body. The top and bottom flanges of the side bars extend inwardly at certain points to form integral gussets for the reception of the cross members. The frame is cold-

Packard "Thirty" Described

riveted through being positively rigid jigs, while

The frame is four unusually tical springs. The inches long and inches long. The steel tubing of and heavy gauge. sleeves of the rear tubes pressed into flanged collars the differential housing, making

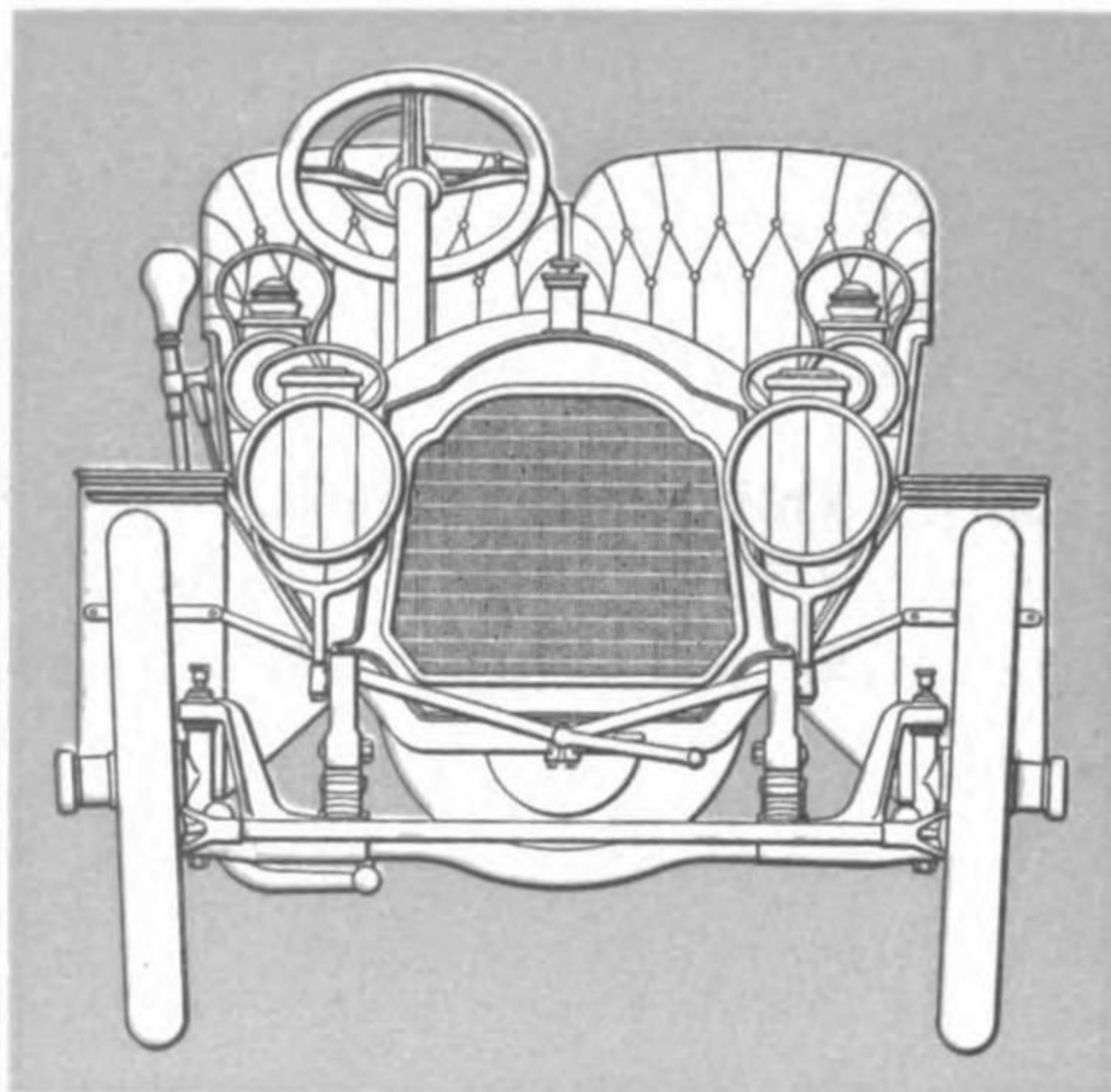

Front View of Packard "Thirty" Runabout

out, the members held in accurate, being assembled.

suspended upon wide, semi-ellip-rear ones are 56 the front ones 40 front axle is of large diameter The stationary axle are steel and riveted within that are bolted to and driving-gear a rigid structure.

The wheel base is $123\frac{1}{2}$ inches, and the tread is $56\frac{1}{2}$ inches. The wheels have been increased in diameter to 36 inches. They are of wood, of the artillery pattern. The front wheels have each ten spokes, and the rear wheels twelve spokes. The wheels run on imported annular ball bearings of increased size. The front tires are 36 by 4 inches, and the rear tires 36 by $4\frac{1}{2}$ inches.

The touring body, in its new combination with 36-inch wheels, has a longer and more stable appearance, and obtains individuality by arched recesses in the rear seat panels to provide clearance for the rear wheels. The body is made of aluminum over wood framework. The seats are upholstered in black straight-grain leather, over curled hair, and with spiral-spring backing throughout. The rear seat cushions have been increased in thickness. There is a folding brass foot-rail in the tonneau, a coat-rail, and suitable pockets for goggles, maps, and other incidentals.

The bonnet is of aluminum, and is made to open from either side, also

Packard "Thirty" Described

being readily removable. It is secured by hand latches and a leather strap. When opened or removed it exposes the motor and accessory mechanism. All fenders are of aluminum. The front fenders are easily detachable and are provided with integral metal aprons to prevent mud and water from splashing between the fenders and the frame or bonnet.

In the standard finish the entire body, bonnet, and frame are Richelieu blue, with black moldings and fine striping of cream yellow. The wheels, axles, springs, and other running-gear parts below the frame are cream yellow, striped with Richelieu blue.

The equipment consists of two side oil lamps; one rear oil lamp; brackets for head lights; horn, tube and bulb; complete set of tools; front and rear storm

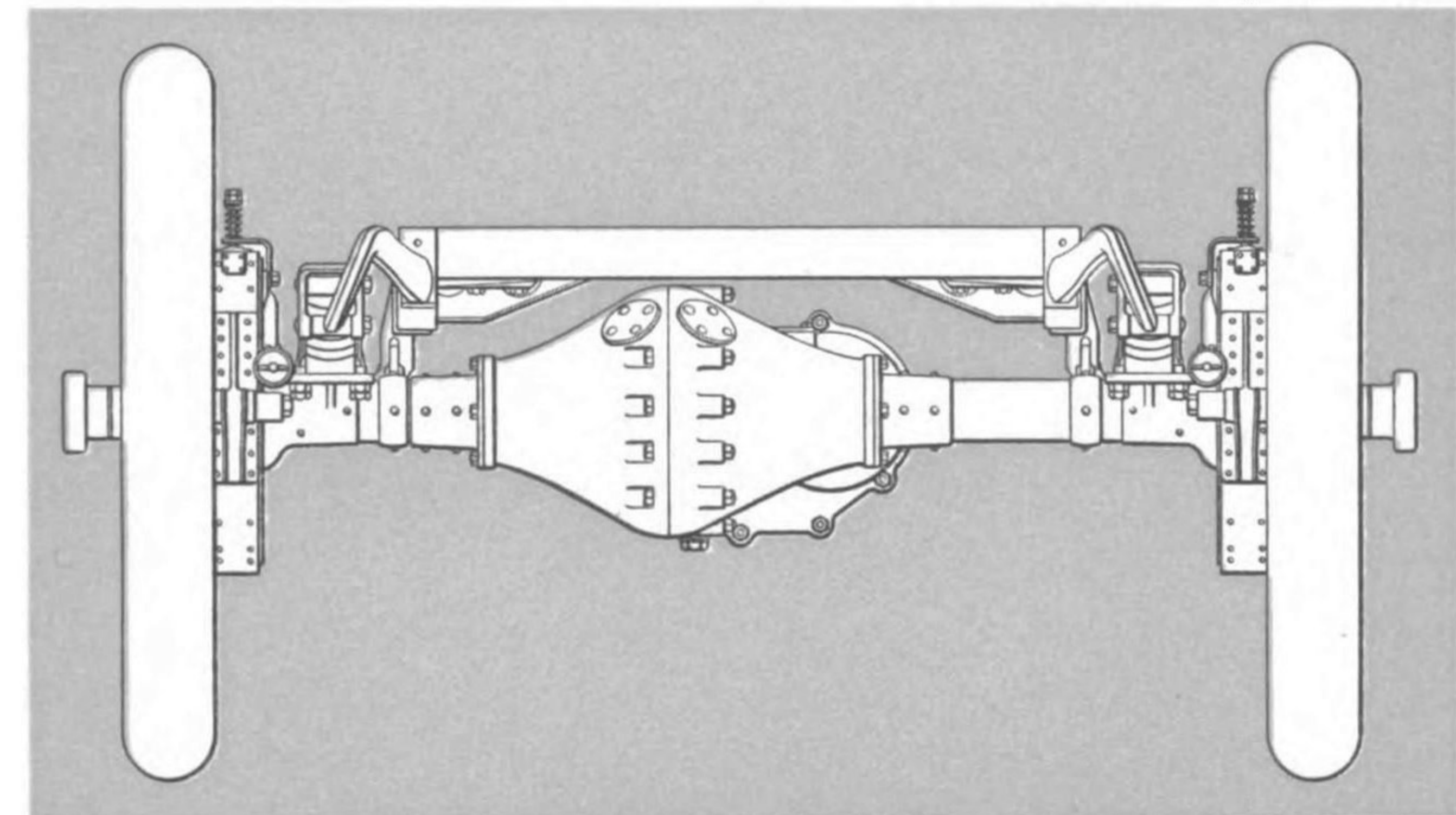

Rear Elevation of Packard "Thirty" Chassis

aprons; irons for extension cape cart top; tire-repair outfit, including jack and pump, and irons for carrying extra tires. The price, in standard finish and equipment, is \$4,200, f. o. b. factory.

As a limousine or landaulet, the chassis is identical with that of the touring

Packard "Thirty" Described

car. In the case of the runabout, however, there are several differences in keeping with the requirements.

The wheel base is 108 inches instead of 123 $\frac{1}{2}$ inches. The motor and the driver's seat are placed farther back on the frame than in the touring car, thus making the bonnet longer and properly distributing the weight. The steering post has a greater rake. The divided front seat is lower, relative to the floor. The gasoline tank has a capacity of twenty-seven instead of twenty-one gallons and is placed at the rear of the frame. The gasoline feed to the carburetor is by a simple, automatic pressure system. Above the gasoline tank is a rumble seat. The standard tire equipment is 36 by 3 $\frac{1}{2}$ inches in front and 36 by 4 inches in the rear. There are no other notable differences between the runabout and the touring car. The former is just as essentially a Packard "Thirty" as the latter.

