

1963 Rambler Station Wagons

More Fun... More Function... More Features!



CLASSIC 6 * AMBASSADOR V-8 * AMERICAN



New one-piece outer unside is completely galvanized and welded to a one-piece inner unside. The whole panel forms a complete box structure around door openings and rocker panels. Rounded "no-weld" corners at pillars give greater strength. Doors fit snugly. Entire body uses over seven times more rust-fighting *galvanized* steel for longer life.

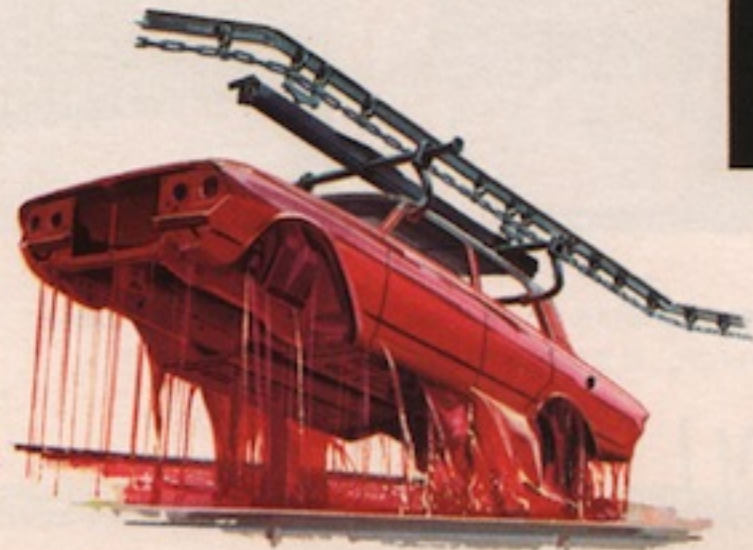

Every Rambler body is Deep-Dipped clear up to the roof in a primer paint bath. Rambler's exclusive Deep-Dip rustproofing, plus generous use of galvanized parts, means the industry's greatest protection against rust and corrosion. Super-quality, double-coat baked enamel in 13 colors plus 42 optional two-tones preserve lasting beauty.

The Most Advanced Station Wagons On The Road In Construction, Design and Value!

The 1963 Rambler Cross Country Station Wagons—both Classic 6 and Ambassador V-8—move years ahead of the industry with Advanced Unit Construction, incorporating the new one-piece uniside body panels. It is a completely new concept of unit construction that makes possible Rambler's sparkling new beauty and the new curved glass side windows that hush wind noise and give more shoulder room. Advanced Unit Construction means added structural strength . . . far greater rust protection with over seven times more galvanized steel. Rambler station wagons offer more *fun* . . . more *function* . . . more *features* . . . than ever in 1963. You have a wide selection of models to meet every work-and-play need.





1963 RAMBLER CLASSIC SIX 770 4-DOOR CROSS COUNTRY

1963 RAMBLER CLASSIC SIX

Cross Country Station Wagon

Here is America's only station wagon that offers you the Best of Both: Big-car room, performance, and comfort . . . small-car economy and handling ease . . . plus All-New Beauty! There's lots of room for all the family and their luggage and gear on any trip—long or short. You and your family can choose from a wide selection of station wagon models in 550, 660 and 770 series for 1963!

New hidden compartment under cargo deck of Classic and Ambassador wagons provides safe storage for camera, binoculars, purse and other valuables.



Rich elegance plus practical durability are combined in the new 1963 Rambler station-wagon interiors. Take your pick of a wide selection of fabrics and vinyls or combinations of both. New "Control-Center" instrument panel groups all dials and controls directly in front of driver for utmost convenience.



1963 RAMBLER AMBASSADOR V-8 990 4-DOOR CROSS COUNTRY

1963 RAMBLER AMBASSADOR V-8

Cross Country Station Wagon

Here is the absolute tops in station-wagon style, luxury and performance . . . the Rambler Ambassador V-8 for 1963 presents new action-packed beauty that brings you all you ever dreamed about in station-wagon living—and more! The 250 HP short-stroke design Ambassador V-8 engine with an 8.7:1 compression ratio gives superb performance and outstanding V-8 economy on regular grade fuel. Optional 4-barrel carburetor and 9.7:1 compression ratio gives 270 HP rating on premium fuel for even finer performance. New alternators are standard on all Ambassadors, and on other models with air conditioning. Choose from 2-seat, 4-door models or the 3-seat Cross Country with a wide-opening fifth door.

New smooth-stepped roof and newly-designed Roof-Top Travel Rack impart smart, practical look. Travel Rack (standard) carries extra luggage.



On Rambler Classic and Ambassador station wagons, the rear window rolls down handily into tail gate. Complete box-section pillar structure around tail-gate opening is welded to underbody for greatest strength.



1963 RAMBLER CLASSIC CROSS COUNTRY 660
5-DOOR, 3-SEAT CROSS COUNTRY

Tail gate is a *fifth door* that swings wide to a full 90 degrees in Rambler 3-seat wagons. Third-seat passengers step right in to comfortable solid-foam seat. No tail gate to climb over. Makes cargo loading a cinch. Opt. on 2-seat wagons.

America's Largest Selling 6-Cylinder Station Wagons

RAMBLER CLASSIC 6



1963 RAMBLER CLASSIC 550
4-DOOR, 2-SEAT CROSS COUNTRY
Also available in 660 series

The High-Performance, Luxury Station Wagon...

RAMBLER AMBASSADOR V-8



1963 AMBASSADOR V-8 990 5-DOOR,
3-SEAT CROSS COUNTRY

Never before such style and luxury inside and out in a station wagon. Interiors are richly appointed, yet have the durability and long-wearing qualities so necessary in rugged station-wagon use. Door panels and trim harmonize with the many fabric and vinyl combinations available for '63.



1963 AMBASSADOR V-8 880 4-DOOR, 2-SEAT CROSS COUNTRY
Also available in 990 series



RAMBLER AMERICAN 440 4-DOOR STATION WAGON



RAMBLER AMERICAN 220 2-DOOR STATION WAGON

The Smart Economy Station Wagon...

1963 RAMBLER AMERICAN



You get family fun—and function, too—in a 1963 Rambler American station wagon. Here's all the riding comfort of a sedan combined with generous cargo-carrying capacity for travel or shopping. Choose from 2-door models in the 220 and 330 series and 4-door models in the 220, 330 and 440 series. Available in 13 solid colors and 42 two-tone combinations, with a choice of many harmonizing interiors, one of which is shown at left. Roof-Top Travel Rack is standard on 330 and 440 models. Every Rambler American station wagon is built for family work and play.



RAMBLER AMERICAN 330 4-DOOR STATION WAGON
Also available in 220 series



RAMBLER AMERICAN 330 2-DOOR STATION WAGON



Rambler's exclusive Lounge-Tilt Seat offers the restful comfort of a contoured lounge chair. Seat cushion adjusts for proper knee height merely by using a convenient handle that energizes a hydraulic cylinder. Seat-back reclines for added comfort. The seats glide fore and aft individually for just the right amount of legroom for tall or short driver and passenger. Lounge-Tilt Seat and individually adjustable seats are available for both driver and front-seat passenger. Headrests standard with Lounge-Tilt Seat. These low-cost options bring a degree of personalized comfort not attainable in any other car.

Features Designed With Your Family In Mind!



Twin Travel Beds for comfortable all-night sleeping on camping or vacation trips make up out of optional Airliner Reclining Seats in sedans or wagons.



Nap Couch lets children—and adults, too, sleep the miles away on long trips. Simply lower the right-hand Airliner Reclining Seat to enjoy this unique feature.



One of many transmission options, new Twin-Stick Floor Shift for 990, 770 and 440 models with optional bucket seats and console. Console has a key-locked compartment.

Rambler Gives You
So Much More

At No Extra Cost!



More Maneuverable Than Ever! Its compact turning and size makes the 1963 Rambler even easier to turn, handle and park.

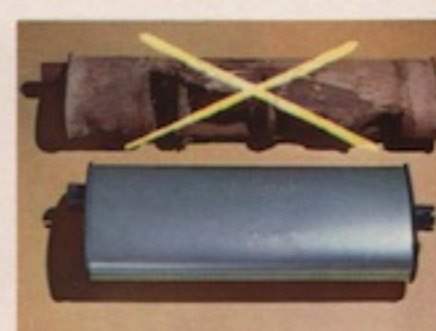

Ceramic-Armored muffler and tailpipe give lasting protection against rust. Rambler pays the cost if rust-out occurs.



Double-Safety Brake System has tandem master cylinders. If one set is damaged, the other still works. Self-adjusting brakes also std.



Cushioned-Acoustical Ceiling, exclusive on Ambassador and Classic, cuts road noise 30%—never sags or droops—insulates.



1963 RAMBLER CLASSIC CROSS COUNTRY 660
5-DOOR, 3-SEAT CROSS COUNTRY

Tail gate is a *fifth door* that swings wide to a full 90 degrees in Rambler 3-seat wagons. Third-seat passengers step right in to comfortable solid-foam seat. No tail gate to climb over. Makes cargo loading a cinch. Opt. on 2-seat wagons.

America's Largest Selling 6-Cylinder Station Wagons

RAMBLER CLASSIC 6



1963 RAMBLER CLASSIC 550
4-DOOR, 2-SEAT CROSS COUNTRY
Also available in 660 series

The High-Performance, Luxury Station Wagon...



1963 AMBASSADOR V-8 990 5-DOOR,
3-SEAT CROSS COUNTRY

Never before such style and luxury inside and out in a station wagon. Interiors are richly appointed, yet have the durability and long-wearing qualities so necessary in rugged station-wagon use. Door panels and trim harmonize with the many fabric and vinyl combinations available for '63.

you... **RAMBLER AMBASSADOR V-8**



1963 AMBASSADOR V-8 880 4-DOOR, 2-SEAT CROSS COUNTRY
Also available in 990 series



RAMBLER AMERICAN 440 4-DOOR STATION WAGON



RAMBLER AMERICAN 220 2-DOOR STATION WAGON

The Smart Economy Station Wagon...

1963 RAMBLER AMERICAN



You get family fun—and function, too—in a 1963 Rambler American station wagon. Here's all the riding comfort of a sedan combined with generous cargo-carrying capacity for travel or shopping. Choose from 2-door models in the 220 and 330 series and 4-door models in the 220, 330 and 440 series. Available in 13 solid colors and 42 two-tone combinations, with a choice of many harmonizing interiors, one of which is shown at left. Roof-Top Travel Rack is standard on 330 and 440 models. Every Rambler American station wagon is built for family work and play.



RAMBLER AMERICAN 330 4-DOOR STATION WAGON
Also available in 220 series



RAMBLER AMERICAN 330 2-DOOR STATION WAGON



Rambler's exclusive Lounge-Tilt Seat offers the restful comfort of a contoured lounge chair. Seat cushion adjusts for proper knee height merely by using a convenient handle that energizes a hydraulic cylinder. Seat-back reclines for added comfort. The seats glide fore and aft individually for just the right amount of legroom for tall or short driver and passenger. Lounge-Tilt Seat and individually adjustable seats are available for both driver and front-seat passenger. Headrests standard with Lounge-Tilt Seat. These low-cost options bring a degree of personalized comfort not attainable in any other car.

Featu



Twin Travel Beds for comfortable camping or vacation trips make...
Reclining Seats in sedans or wag

Rambler Gives
So Much More
At No Extra Cost

Features Designed With Your Family In Mind!



Twin Travel Beds for comfortable all-night sleeping on camping or vacation trips make up out of optional Airliner Reclining Seats in sedans or wagons.



Nap Couch lets children—and adults, too, sleep the miles away on long trips. Simply lower the right-hand Airliner Reclining Seat to enjoy this unique feature.



One of many transmission options, new Twin-Stick Floor Shift for 990, 770 and 440 models with optional bucket seats and console. Console has a key-locked compartment.

Rambler Gives You
So Much More

At No Extra Cost!



More Maneuverable Than Ever! Its compact turning and size makes the 1963 Rambler even easier to turn, handle and park.

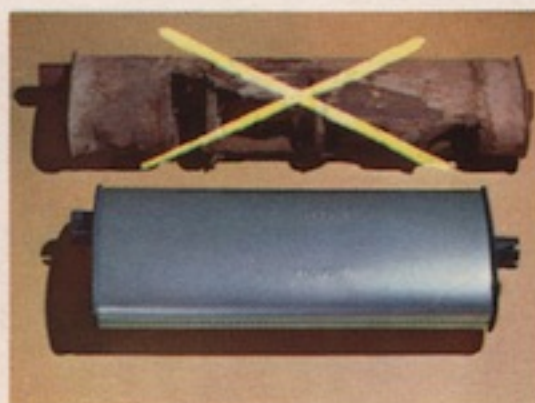

Ceramic-Armored muffler and tailpipe give lasting protection against rust. Rambler pays the cost if rust-out occurs.



Double-Safety Brake System has tandem master cylinders. If one set is damaged, the other still works. Self-adjusting brakes also std.



Cushioned-Acoustical Ceiling, exclusive on Ambassador and Classic, cuts road noise 30%—never sags or droops—insulates.

1963 Rambler Station Wagon Specifications

RAMBLER CLASSIC 6 and AMBASSADOR V-8

Classic 6 four-door Cross Country is offered in 550, 660, and 770 series, plus a 660 3-seat wagon. Or choose the Ambassador V-8 in 880 or 990 series, plus a 3-seat 990 wagon. All are on the new, smooth-riding 112" wheelbase and easy-maneuvering length. A wide selection of luxurious, durable interiors is offered. Fold-down tail gate is standard on 2-seat models. Side-hinged "fifth door" for 3-seat models is optional on 2-seat models. Many options including special suspension components are offered.

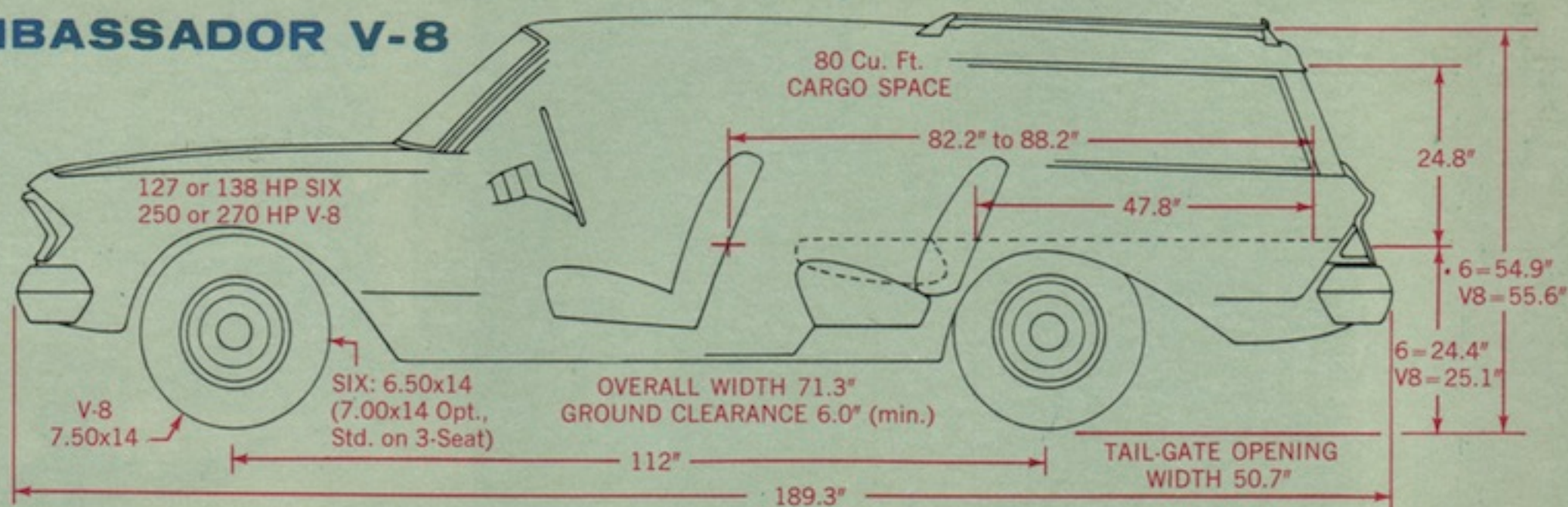

RAMBLER AMERICAN

Select an economy-minded wagon to suit your purse and pleasure! There are family-sized 2-door models in 220 and 330 series, plus 4-door models in all series including 440. You'll find generous cargo space, with wide tail gates for easy loading and unloading. Many options including special suspension components are offered. A multitude of engines, transmissions and axle ratios will fill every need. And a choice of smart interiors make American wagons a delight to drive and own.

