

05 SIERRA

GMC



Strength and leadership
rolled into one.

Why is the GMC Sierra the first choice of so many discerning pickup drivers? Maybe it's because Sierra has so many other firsts going for it. Sierra was the first pickup with precise, robust, hydroformed frame components. Sierra was also first with OnStar. First with a Tow/Haul mode integrated into every automatic transmission. First to offer the incredible handling benefits of QuadraSteer four-wheel steering. And for 2005, first with an available fuel-saving gasoline/electric hybrid powertrain.* Bottom line: Sierra is a respected technology leader among full-size pickups. And the latest in a long line of legendary trucks from the engineers at GMC.

*Based on 2004 Model Year data for GM Large Pickup segment and the latest published competitive information available at time of printing. Excludes other GM vehicles.



GMC
BUILDING LEGENDS



SIERRA DENALI 1500 Crew Cab, shown in Onyx Black with interim available 20-inch aluminum wheels.

05 **SIERRA DENALI**

SIERRA DENALI. EXTRAORDINARY TECHNOLOGY, POWER, LUXURY AND STYLE.

NEW FOR 2005, the Sierra Denali Crew Cab is the most advanced, most luxurious pickup GMC has ever built. A standard Z71 off-road suspension and all-wheel drive (AWD) make for outstanding sure-footedness in every season. The Vortec 6000 V8 generates 345 horsepower and 380 lb.-ft. of torque, which translates into excellent acceleration and a towing capacity of up to 3674 kg (8100 lb.). And then there are such standard upscale appearance features as fog lights, chrome tubular side steps and a sharp monochrome paint treatment. Add it all together and the conclusion is obvious. Sierra Denali is literally in a class by itself.

Unmatched



SIERRA DENALI interior, shown in Sandstone.

05 SIERRA DENALI INTERIOR



SIERRA DENALI. LUXURY AND AMENITIES THAT RIVAL MANY FINE SEDANS.

SIERRA DENALI IS ONE OF THE FEW FULL-SIZE PICKUPS to offer its occupants true luxury-class accommodations. The passenger compartment has the space to handle as many as five adults with ease. The 10-way power adjustable front bucket seats feature heated leather seat inserts and a driver's seat memory function that can save two preferred seating positions and restore either at the touch of a button. A powerful dual-zone automatic climate control system achieves your desired temperature quickly, regardless of what the weather may be doing outside. And for your entertainment, Sierra Denali packs a superb AM/FM stereo system complete with an in-dash six-disc CD changer and no fewer than six Bose premium speakers.

Luxury



SIERRA 1500 SLT Crew Cab 4x4, shown in Silver Birch Metallic.

05 SIERRA 1500/1500 HD

SIERRA 1500/1500 HD. THE RIGHT CHOICE. FOR THE RIGHT REASONS.



AT GMC, we know half-ton pickup customers need hard-working power. That's why the Sierra 1500 Extended Cab 4x4 delivers up to 310 horsepower and, in the 1500HD Crew Cab, as much as 360 lb.-ft. of torque. We know you need serious capability, so we engineered Sierra 1500HD Crew Cab with maximum payload and towing capacities of 1394 kg (3073 lb.) and 4627 kg (10,200 lb.) respectively. We also know you want to have your truck your way. That's why we offer such an incredible array of features, body styles and models. Sierra 1500s. There are so many reasons to choose one.

Capable

- a. Sierra 1500 SL Regular Cab 4x4, shown in Sport Red Metallic with Sportside box.
- b. Sierra 1500 SLT Extended Cab 4x4, shown in Silver Birch Metallic with available Quadrateer.



SIERRA 2500HD SLT Crew Cab 4x4, shown in Summit White with available equipment.

05 **SIERRA 2500HD/3500**

SIERRA 2500HD/3500. AS SERIOUS AS IT GETS.



THE MOST CAPABLE PICKUPS ever from GMC, the Sierra 2500HD and 3500 are engineered to take on the toughest jobs and the biggest challenges. Powertrain choices include the renowned Vortec 6000 V8 and a big-block Vortec 8100 V8 that generates 450 lb.-ft. of torque to handle heavy trailers with ease. Then there's the awesome Duramax 6600 V8 Diesel, which puts out a full 605 lb.-ft. of torque* – the most of any full-size pickup engine.** No matter which engine you choose, Sierra 2500HD and 3500 offer some seriously impressive capabilities. Payloads range up to 2493 kg (5497 lb.), and maximum fifth-wheel towing capacities go as high as 7575 kg (16,700 lb.).

*When equipped with the available Allison automatic transmission.

**Based on 2004 Model Year data for GM Large Pickup segment and latest published competitive information available at time of printing. Excludes other GM vehicles.

- a. Sierra 2500HD SL Regular Cab 4x4, shown in Silver Birch Metallic.
- b. Sierra 3500 SLT Crew Cab with dual rear wheels, shown in Fire Red with available equipment.

Muscle



SIERRA 1500 SLT Extended Cab, shown in Pewter.

05 SIERRA INTERIOR



NEVER LEAVE CIVILIZATION BEHIND.

RUGGED AND HARDWORKING though they definitely are, today's Sierras also have their softer side. In every model and body style, Sierra offers a spacious, intelligently designed passenger compartment that offers excellent riding comfort. There's also a long list of standard amenities, including dual-zone climate controls, tinted glass, a Driver Information Centre and much more. And if you're after a truck that rewards you for all the hard work you do, take a look at a Sierra SLT. Every SLT offers full-feature high-back front bucket seats with heated leather inserts, a premium sound system complete with an in-dash six-disc CD changer, the safety and convenience of OnStar and much more.



- a. All Sierra SLT models are equipped with full-feature 10-way power adjustable bucket seats.
- b. The front bucket seats in SLT models also feature heated leather seat inserts and a two-position driver's seat memory function.
- c. To entertain rear-seat passengers on long trips, a DVD entertainment system is available in Crew Cabs.



Comfortable



SIERRA SLT instrument panel.

05 **SIERRA INSTRUMENTS/CONTROLS**



INTELLIGENT DESIGN HELPS KEEP YOU CALM, COLLECTED AND CONFIDENTLY IN CONTROL.

THERE'S A POWERFUL AND UNDENIABLE LOGIC to Sierra's instrumentation and driver controls. Everything simply feels *right*, right from the moment you first ease into the driver's seat. The white-on-black analogue gauges and standard Driver Information Centre tell you everything you need to know quickly and clearly. A tilt adjustable steering column is standard, and in SLT models the steering wheel features switches that let you adjust the audio system without ever taking your eyes off the road. You'll find that even the climate control system has been designed to make driving easier and safer, with knobs and buttons that are easy to operate even when you're wearing gloves.



- a. SLT models let you personalize a wide range of vehicle systems to your preferred settings via the Driver Information Centre.
- b. An automatic dual-zone climate control system is standard on Sierra SLT models.
- c. A power sliding glass sunroof is available on certain Extended and Crew Cab models.



Control

TIP THE BALANCE OF POWER IN YOUR FAVOUR.

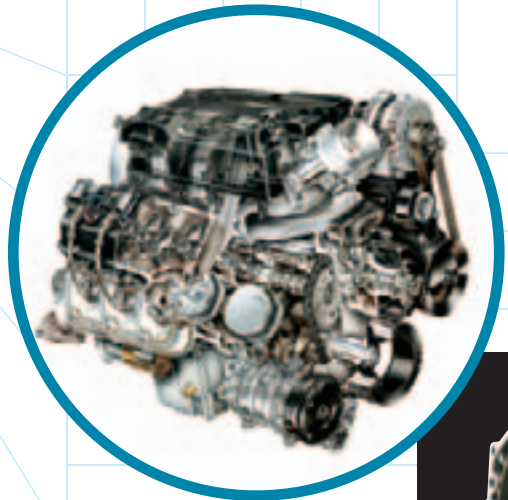

SIERRA'S AVAILABLE VORTEC 8100 V8 is an exceptional performer with 450 lb.-ft. of torque. It's also a low-maintenance engine that doesn't require its first scheduled tune-up for 166,000 kilometres of regular service.*

*Maintenance needs vary with different uses and driving conditions. Please refer to the Owner's Manual for more information.

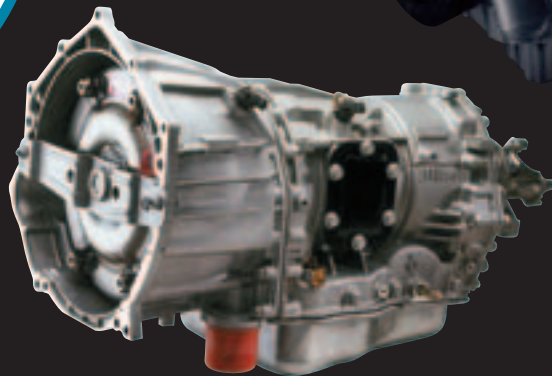

THE AVAILABLE ALLISON 1000 SERIES heavy-duty 5-speed automatic transmission is the ideal partner for either the Duramax 6600 V8 Diesel or the Vortec 8100 V8. A Tow/Haul mode and engine grade braking are standard features.



UPGRADED FOR 2005 to generate a whopping 605 lb.-ft. of torque[†], the Duramax 6600 V8 Diesel engine has more torque than any other pickup engine in its class.^{**} Key features include 4 valves per cylinder, an inter-cooled turbocharger and direct pilot injection.

[†]When equipped with the available Allison automatic transmission. Duramax 6600 V8 Diesel with 6-speed manual transmission produces 300 hp and 520 lb.-ft. of torque. ^{**}Torque ratings are based on 2004 Model Year data for GM Large Pickup segment and latest published competitive information available at time of printing. Excludes other GM vehicles.

SIERRA OFFERS THE MOST POWERTRAIN CHOICE in any full-size pickup. The range of Vortec gasoline engines begins with the efficient Vortec 4300 V6 and comprises no fewer than five V8s, including a new 310 horsepower aluminum-block version of the Vortec 5300 and the big-block Vortec 8100 V8. There's also the stump-pulling Duramax Diesel and, new for 2005, an innovative fuel-saving hybrid gas/electric powertrain featuring a unique version of the Vortec 5300 V8.^{**} For technology, torque and selection, nobody beats Sierra. ^{**}Limited availability.

05 SIERRA PERFORMANCE

Sierra Engine/Transmission Availability

| Series/Cab Type | Model Number | Vortec 4300 V6 ¹ 195 hp @ 4600 rpm 260 lb.-ft. torque @ 2800 rpm | Vortec 4800 V8 ² 285 hp @ 5200 rpm 295 lb.-ft. torque @ 4000 rpm | Vortec 5300 V8 ³ 295 hp @ 5200 rpm 335 lb.-ft. torque @ 4000 rpm | Vortec 6000 V8 ⁴ 300 hp @ 4400 rpm 360 lb.-ft. torque @ 4000 rpm | Vortec 8100 V8 ⁵ 330 hp @ 4200 rpm 450 lb.-ft. torque @ 3200 rpm | Duramax 6600 V8 ⁶ Turbo Diesel 310 hp @ 3000 rpm 605 lb.-ft. torque @ 1600 rpm |
|-----------------|---------------|--|--|--|--|--|---|
| 1500 | | | | | | | |
| Regular Cab | C15703 | S | 0 | 0 | - | - | - |
| | C15903 | S | 0 | 0 | - | - | - |
| | K15703 | S | 0 | 0 | - | - | - |
| | K15903 | S | 0 | 0 | - | - | - |
| Extended Cab | C15753 | S | 0 | 0 | - | - | - |
| | C15953 | - | - | S | - | - | - |
| | K15753 | - | S | 0* | - | - | - |
| | K15953 | - | S | 0 | - | - | - |
| Crew Cab | C15543 | - | - | S | - | - | - |
| | K15543 | - | - | S | - | - | - |
| | K15543/Denali | - | - | - | S** | - | - |
| 1500HD | | | | | | | |
| Crew Cab | C15743 | - | - | - | S | - | - |
| | K15743 | - | - | - | S | - | - |
| 2500HD | | | | | | | |
| Regular Cab | C25903 | - | - | - | S | 0 | 0 |
| | K25903 | - | - | - | S | 0 | 0 |
| Extended Cab | C25753 | - | - | - | S | 0 | 0 |
| | C25953 | - | - | - | S | 0 | 0 |
| | K25753 | - | - | - | S | 0 | 0 |
| | K25953 | - | - | - | S | 0 | 0 |
| Crew Cab | C25743 | - | - | - | S | 0 | 0 |
| | C25943 | - | - | - | S | 0 | 0 |
| | K25743 | - | - | - | S | 0 | 0 |
| | K25943 | - | - | - | S | 0 | 0 |
| 3500 | | | | | | | |
| Regular Cab | K35903 | - | - | - | S | 0 | 0 |
| Extended Cab | C35953 | - | - | - | S | 0 | 0 |
| | K35953 | - | - | - | S | 0 | 0 |
| Crew Cab | C35943 | - | - | - | S | 0 | 0 |
| | K35943 | - | - | - | S | 0 | 0 |

S = Standard 0 = Optional

1 - A 5-speed manual transmission is standard. A 4-speed automatic transmission is optional.

2 - A 5-speed manual transmission is standard. A 4-speed automatic transmission is optional on most models, standard on models indicated with an S.

3 - A 4-speed automatic transmission is required and is standard on 1500 Crew Cabs. Aluminum block 5300 V8, available on 1500 Extended Cab 4x4s, produces 310 hp @ 5200 rpm.

4 - In models equipped with a Vortec 6000 V8, a heavy-duty 5-speed manual transmission is standard. A heavy-duty 4-speed automatic transmission is optional.

5 - A 6-speed ZF manual transmission is standard. A 5-speed Allison 1000 automatic transmission is optional. Duramax 6600 V8 Turbo Diesel with 6-speed manual transmission produces 300 hp @ 3100 rpm.

* When equipped with QuadraSteer, the Vortec 5300 is standard.

** The Vortec 6000 V8 in Sierra Denali produces 345 hp @ 5200 rpm and 380 lb.-ft. torque @ 4000 rpm and includes a 4-speed automatic transmission.

Note: Some models with up-level trims and the 1500 and 2500 Crew Cabs include a 4-speed automatic transmission. Some up-level series include a larger engine than indicated on this chart.

Please ask your Sales Consultant for details.

THE IMMOVABLE OBJECT DOESN'T STAND A CHANCE.

HAULING AND TOWING heavyweight loads are two of the things Sierra does best. Sierra 1500 features GVWRs up to 3175 kg (7000 lb.) and towing capacities as high as 4082 kg (9000 lb.)* Sierra 1500HD features towing capacities up to 4627 kg (10,200 lb.)* If that's not enough, check out Sierra 2500HD and 3500. The 3500 offers a maximum GVWR of 5171 kg (11,400 lb.), and equipped with a fifth-wheel hitch and other appropriate hardware, a Sierra 3500 dual rear wheel Regular Cab 4x4 can tow up to 7575 kg (16,700 lb.).

*When properly equipped.





SIERRA 1500HD SLT Crew Cab 4x4, shown in Silver Birch Metallic with available Quadrasteer.

05 **SIERRA TOWING**

ENGINEERED TO HELP YOU TOW LIKE A PRO.



SIERRA'S INTELLIGENT TECHNOLOGY lets you tow with a new kind of confidence. Sierra automatic transmissions include a Tow/Haul mode that alters the shift pattern for added performance when you need it. Then there's the amazing QuadraSteer four-wheel steering system that's available on 1500HD Crew Cabs and selected Sierra 1500 Extended Cab 4x4 models. On the highway your rig is noticeably more stable, even in crosswinds, and low-speed manoeuvring and backing up have never been easier. Other towing-friendly features include available extendable camper mirrors and an available Trailering Special Equipment Package with a weight-distributing platform hitch, a heavy-duty eight-lead wiring harness and much more. Refer to the Trailering with GMC Trucks brochure for more information.

Intelligent

- a. Engaging the Tow/Haul mode for increased performance under load is a simple matter of pressing a button on the end of the transmission shift lever.
- b. The available power camper mirrors also feature integral heaters, power adjustments and in-glass turn signals.
- c. At highway speeds, QuadraSteer turns the rear wheels in the same direction as the front wheels, enhancing stability. At low speeds it turns them in the opposite direction, dramatically reducing Sierra's turning circle for improved manoeuvrability.

THE ENGINEERING BEHIND THE LEGEND.

SIERRA OWES ITS MUCH-PRAISED STRENGTH, QUALITY AND DURABILITY to GMC's advanced truck technology. Take the robust, high-tech, modular ladder frame, for example. The front rails are shaped by a leading-edge technique called hydroforming, in which steel is moulded into the desired form by highly pressurized water. The result is an extremely precise component that's simultaneously strong and lightweight – a definite win-win combination. The Sierra frame also uses stronger tubular cross members in place of conventional stampings. It's robot-welded in many places, too, for stronger, more durable joints than conventional rivets could achieve.



SIERRA 2500HD SLE Crew Cab 4x4, shown in Carbon Metallic with available equipment.

05 **SIERRA TECHNOLOGY**

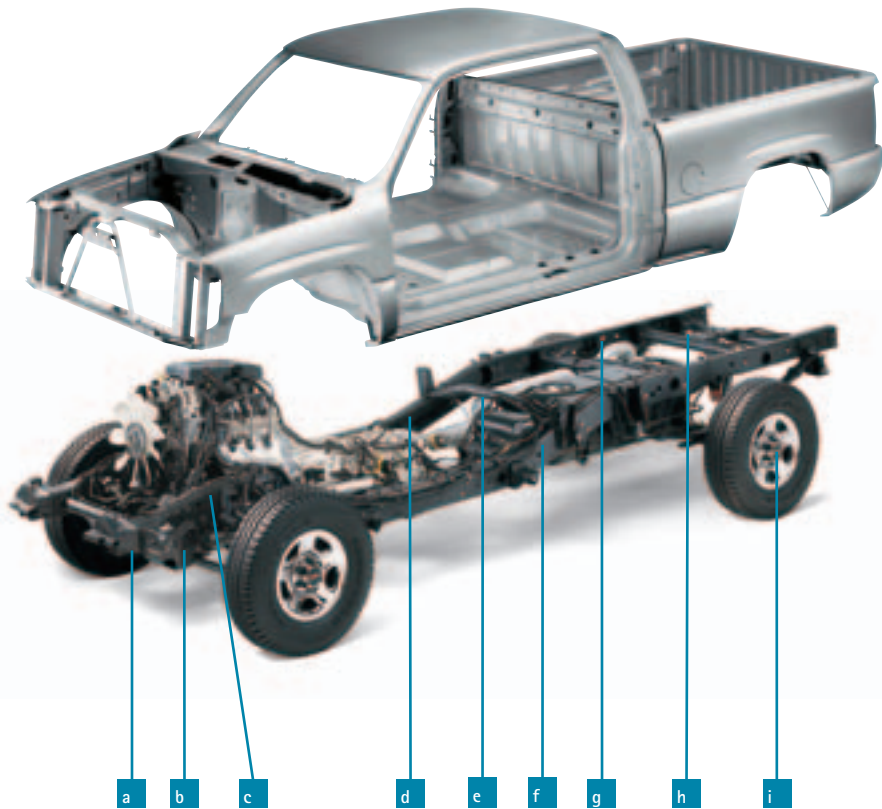

- a. On 1500 models, easily replaced crush caps at the front end of the frame are designed to absorb energy in a collision, in order to cushion the passenger compartment.
- b. Sierra's hydroformed front frame section allows the precision mounting of suspension components, resulting in better wheel alignment and improved ride and handling characteristics.
- c. Formed through the application of very high levels of hydraulic pressure, the steel front frame section is stronger, lighter and more dimensionally precise than conventional welded steel frames.
- d. The mid-frame begins as a solid, straight piece of high-strength steel. The steel is then rolled into shape without stamping, allowing it to retain its strength with no added mass.
- e. To provide long life and reduce maintenance requirements, Sierra's exhaust system is made of stainless steel. Sections behind the catalytic converter are aluminized for an improved appearance.
- f. To eliminate any need for heat shields as used on some competitive pickup trucks, the corrosion-fighting wax applied to the Sierra frame has a very high melting point – 146°C (295°F).
- g. The rear frame is a strong straight-rail design that easily accepts a variety of trailer hitches. It also contributes to the high trailering capacities of all Sierra models.
- h. For added rigidity, the Sierra frame is reinforced by a series of tubular cross members. Unlike the heavy stampings used on some competitive vehicles, these cross members add strength with less weight.
- i. For added strength, Sierra half-ton models ride on six-bolt wheels. Three-quarter-ton models go even further, with standard eight-bolt wheels.



The closed-section hydroformed front frame members provide maximum torsional strength, resulting in improved ride and handling.



In the mid-frame area, a "lipped" C-section design provides greater strength than traditional C-section members.



The C-section members that make up the rear frame are an ideal combination of strength and light weight.



Tubular cross members resist the forces acting on the main frame rails and contribute to a smooth, steady ride.



SIERRA 1500 SLT Crew Cab 4x4, shown in Sport Red Metallic.

05 SIERRA SAFETY & SECURITY

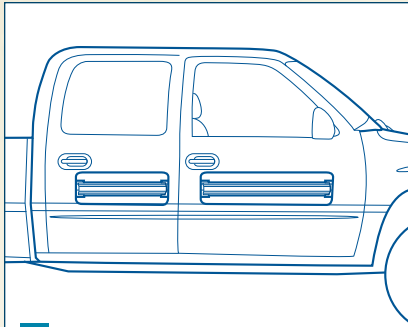

a

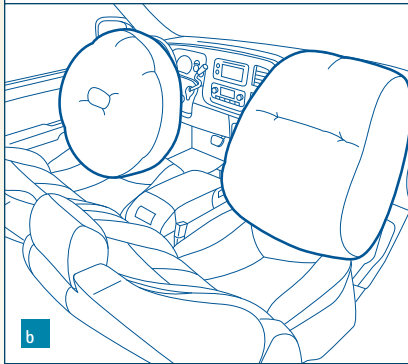

b

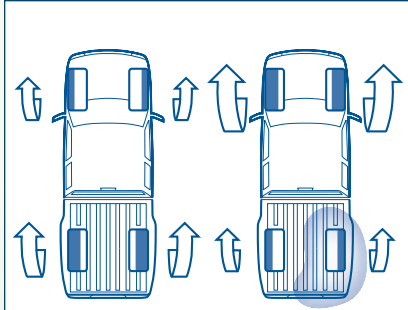

c

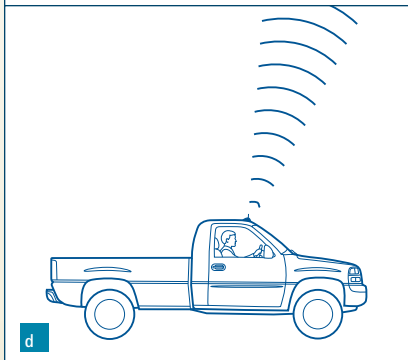

d

MEET YOUR BODYGUARD.

WITH SIERRA, safety is a subject with many different aspects. For instance, Sierra helps you keep collisions from happening in the first place. Good visibility, well-designed controls and responsive handling and braking all help you to stay out of trouble. Sierra also includes dozens of features, like standard frontal air bags[†], that help to prevent or reduce injuries if a collision proves unavoidable. Sierra is also equipped to safeguard your investment, with a standard PASSLock theft-deterrent system that automatically shuts down the fuel system for ten minutes if the correct key is not used.

- a. Sturdy steel beams in every Sierra door help prevent intrusions into the passenger compartment in certain side impacts.
- b. Dual frontal air bags are standard. Sierra 1500 models feature dual-stage air bags equipped with a passenger-side sensing system that automatically turns the air bag off if the seat is empty or contains a child seat or a small passenger.[†]
- c. The available Autotrac 4x4 system on 1500 models senses wheel-spin and automatically distributes engine power to all 4 wheels to help keep you moving.
- d. OnStar System with one year of the Safe & Sound plan is standard on SLT and Denali models (available on SLE models).

[†]A NOTE ON CHILD SAFETY: Always use safety belts and proper child restraints, even in vehicles equipped with air bags. Children are safer when properly secured in a rear seat. Never place a rear-facing infant restraint in the front seat of any vehicle equipped with an active air bag. Refer to the vehicle Owner's Manual and child safety seat instructions for more information. Air bag inflation can cause severe injury or death to anyone too close to the air bag when it deploys. Be sure every occupant is properly restrained.



A General Motors Subsidiary

Always there. Always ready.

For over a century, GMC has advanced the state of the art in trucks by the intelligent application of technology. Case in point: OnStar. OnStar uses advanced communications technology to enhance your peace of mind whenever you're in your GMC Truck. All it takes is the touch of a single OnStar button inside your vehicle to connect you with one of our Advisors at the OnStar Centre.* They are standing by, ready to provide support 24 hours a day, 365 days a year.

What can OnStar Advisors do for you? They not only provide information and a range of other direct assistance services – but also, in an emergency, they will contact emergency service providers. And if air bags are deployed in your vehicle, an Advisor will contact you to determine if you need assistance. Your Advisor can also perform a remote diagnostic check of your engine and the electrical components in your vehicle.

Another convenient feature is OnStar Personal Calling,** which uses a button to activate the hands-free, voice-activated wireless phone that's integrated into your vehicle. It's there just in case your hand-held cellphone is lost, forgotten or has a low battery. Even better, there are no additional monthly system access fees, or additional long distance and roaming charges. And as a new customer, you will receive 30 trial minutes.

Knowing you have OnStar on board provides a powerful sense of added security. Just ask the more than 100,000 people who have become OnStar subscribers in Canada. How hard does OnStar work for you? The facts speak for themselves: every month in Canada OnStar Advisors handle an average of 7,100 routing calls, 2,000 emergency calls, 1,900 door unlocks, and 1,050 Roadside Assistance dispatches.

OnStar offers two different service plans, allowing you to select the services that are important to you. The Safe & Sound plan is included for one year on Sierra SLT and Denali models and is available on SLE. The available Direction & Connections plan offers route information, as well as a host of other convenience services. See your dealer for more details about plans available for GMC Sierra.

*Subscription Agreement necessary. OnStar services require vehicle electrical system and wireless service to be available and operating for features to function properly. OnStar relies on existing emergency service providers as well as wireless and satellite technologies and is subject to their limitations. Due to the transition of the wireless industry from analogue to digital technology, as of January 1, 2008, OnStar plans to offer service only through equipment that operates on the digital network, which may require the purchase of a system upgrade. Call 1-888-4ONSTAR (1-888-466-7827), see your OnStar Owner's Guide, or visit www.onstarcanada.com for system information and details.

**Requires OnStar Personal Calling-enabled vehicle, existing OnStar service contract and prepaid calling minutes. OnStar voice recognition system may not recognize all voices. Available in most markets.



05 **ACCESSORIES**



CUSTOMIZATION MADE EASY.

Genuine GM Accessories let you take the styling and functionality of your new Sierra to an even higher level. They are the only accessories that are integrated into the process of designing your vehicle, ensuring excellent fit, finish and functionality. And only GM Accessories are backed by GM's 3-year/60,000 km TOTAL™ Warranty.* They can also be included in your new-vehicle lease or finance agreement through GMAC. Ask your dealer for a complete list of the GM Accessories available for Sierra, or visit gmcanada.com

*Whichever comes first, when permanently installed by the dealer at the time you purchase or lease your new vehicle.

GM Accessories for Sierra include:

- Moulded box liner
- Tubular box rail protectors
- Side assist steps
- Box extender
- Under-seat storage container
- All-weather floor mats
- New 20-in. alloy wheels
- Bed rug
- Sport tent
- Hard/soft tonneau cover.



Accessories

MODEL SELECTOR.

| SERIES | CAB TYPE | MODEL NUMBER | WHEELBASE MM (IN.) | DRIVETRAIN | GROSS VEHICLE WEIGHT RATING – KG (LB.) | MAXIMUM PAYLOAD* KG (LB.) | PICKUP BOX LENGTH (FT. IN.) | MAX. GROSS TRAILER WEIGHT** – KG (LB.) | SEATING STD./OPT. |
|--------|--------------|-------------------------|-----------------------|------------|---|------------------------------|--------------------------------|---|----------------------|
| 1500 | Regular Cab | C15703 | 3023 (119.0) | 2WD | 2767 (6100) | 850 (1875) | 6' 6" | 3765 (8300) | 3/2 |
| | | C15903 | 3378 (133.0) | 2WD | 2903 (6400) | 925 (2040) | 8' | 3720 (8200) | 3/2 |
| | | K15703 | 3023 (119.0) | 4x4 | 2903 (6400) | 851 (1877) | 6' 6" | 4082 (9000) | 3/2 |
| | | K15903 | 3378 (133.0) | 4x4 | 2903 (6400) | 789 (1739) | 8' | 4037 (8900) | 3/2 |
| | Extended Cab | C15753 | 3645 (143.5) | 2WD | 2812 (6200) | 718 (1583) | 6' 6" | 3629 (8000) | 6/5 |
| | | C15953 | 4001 (157.5) | 2WD | 2903 (6400) | 687 (1514) | 8' | 3538 (7800) | 6/5 |
| | | K15753 | 3645 (143.5) | 4x4 | 2903 (6400) | 631 (1392) | 6' 6" | 3946 (8700) | 6/5 |
| | | K15753/Quadrasteer | 3645 (143.5) | 4x4 | 3130 (6900) | 703 (1549) | 6' 6" | 3765 (8300) | 6/5 |
| | | K15953 | 4001 (157.5) | 4x4 | 2903 (6400) | 551 (1215) | 8' | 3901 (8600) | 6/5 |
| | Crew Cab | C15543 | 3645 (143.5) | 2WD | 3084 (6800) | 823 (1814) | 5' 8.5" | 3493 (7700) | 6/5 |
| | | K15543 | 3645 (143.5) | 4x4 | 3175 (7000) | 772 (1701) | 5' 8.5" | 3810 (8400) | 6/5 |
| | | K15543/Denali | 3645 (143.5) | AWD | 3175 (7000) | 705 (1555) | 5' 8.5" | 3674 (8100) | 5 |
| 1500HD | Crew Cab | C15743 | 3886 (153.0) | 2WD | 3900 (8600) | 1394 (3073) | 6' 6" | 4627 (10,200) | 6/5 |
| | | C15743/Quadrasteer | 3886 (153.0) | 2WD | 3900 (8600) | NA | 6' 6" | 4491 (9900) | 6/5 |
| | | K15743 | 3886 (153.0) | 4x4 | 3900 (8600) | 1254 (2765) | 6' 6" | 4491 (9900) | 6/5 |
| | | K15743/Quadrasteer | 3886 (153.0) | 4x4 | 3900 (8600) | NA | 6' 6" | 4355 (9600) | 6/5 |
| 2500HD | Regular Cab | C25903 | 3378 (133.0) | 2WD | 4173 (9200) | 1825 (4023) | 8' | 7348 (16,200) | 3/2 |
| | | K25903 | 3378 (133.0) | 4x4 | 4173 (9200) | 1707 (3763) | 8' | 7167 (15,800) | 3/2 |
| | Extended Cab | C25753 | 3645 (143.5) | 2WD | 4173 (9200) | 1722 (3796) | 6' 6" | 7212 (15,900) | 6/5 |
| | | C25953 | 4001 (157.5) | 2WD | 4173 (9200) | 1651 (3639) | 8' | 7122 (15,700) | 6/5 |
| | | K25753 | 3645 (143.5) | 4x4 | 4173 (9200) | 1604 (3536) | 6' 6" | 7076 (15,600) | 6/5 |
| | | K25953 | 4001 (157.5) | 4x4 | 4173 (9200) | 1521 (3354) | 8' | 6985 (15,400) | 6/5 |
| | | C25743 | 3886 (153.0) | 2WD | 4173 (9200) | 1619 (3570) | 6' 6" | 7076 (15,600) | 6/5 |
| | Crew Cab | C25943 | 4242 (167.0) | 2WD | 4173 (9200) | 1557 (3432) | 8' | 7031 (15,500) | 6/5 |
| | | K25743 | 3886 (153.0) | 4x4 | 4173 (9200) | 1502 (3312) | 6' 6" | 6940 (15,300) | 6/5 |
| | | K25943 | 4242 (167.0) | 4x4 | 4173 (9200) | 1429 (3151) | 8' | 6532 (14,400) | 6/5 |
| | | C25743 | 3886 (153.0) | 2WD | 4173 (9200) | 1619 (3570) | 6' 6" | 7076 (15,600) | 6/5 |
| 3500 | Regular Cab | K35903 | 3378 (133.0) | 4x4 | 5171 (11,400) | 2493 (5497) | 8' | 7575 (16,700) | 3/2 |
| | | K35903 SRW [†] | 3378 (133.0) | 4x4 | 4491 (9900) | 1921 (4236) | 8' | 7076 (15,600) | 3/2 |
| | Extended Cab | C35953 | 4001 (157.5) | 2WD | 5171 (11,400) | 2429 (5356) | 8' | 7530 (16,600) | 6/5 |
| | | K35953 | 4001 (157.5) | 4x4 | 5171 (11,400) | 2292 (5054) | 8' | 7394 (16,300) | 6/5 |
| | | K35953 SRW [†] | 4001 (157.5) | 4x4 | 4491 (9900) | 1724 (3801) | 8' | 6895 (15,200) | 6/5 |
| | Crew Cab | C35943 | 4242 (167.0) | 2WD | 5171 (11,400) | 2338 (5155) | 8' | 7439 (16,400) | 6/5 |
| | | K35943 | 4242 (167.0) | 4x4 | 5171 (11,400) | 2202 (4854) | 8' | 7303 (16,100) | 6/5 |
| | | K35943 SRW [†] | 4242 (167.0) | 4x4 | 4491 (9900) | 1626 (3585) | 8' | 6804 (15,000) | 6/5 |

*Payload includes passengers, equipment and cargo. Higher payloads may require optional equipment. Payloads are approximate and will change with the addition of optional or aftermarket equipment. Consult your dealer or equipment supplier for details.

**Trailer ratings are calculated using an automatic transmission and assuming only the driver is in the tow vehicle. Trailer Weight (also called Trailer Towing Capacity) is the weight of a trailer, its load or contents plus any other weight added to the tow vehicle. Ball-hitch ratings are shown for 1500 and 1500HD models. Fifth-wheel ratings are shown for 2500HD and 3500 models; ball-hitch ratings are 5443 kg (12,000 lb.). For details, ask your sales consultant for a copy of the Trailing with GMC Trucks brochure. Many trailer towing applications require additional optional equipment.

[†]SRW Single Rear Wheel. NA – Not available at time of printing

DIMENSIONS.

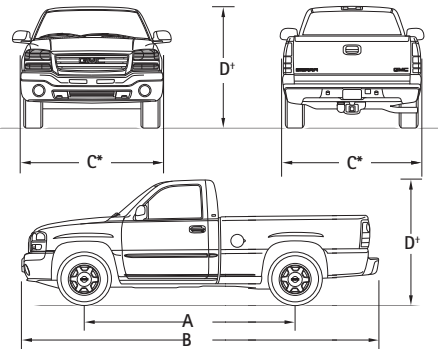

REGULAR CAB STANDARD BOX

| | | | |
|------------------------------------|--------------|---------------------|--------------------|
| A Wheelbase mm (in.) | 3023 (119.0) | | |
| B Overall Length** mm (in.) | 5225 (205.7) | 1500 model | |
| C Width mm (in.) | 1993 (78.5) | (max.)* | Single Rear Wheels |
| D Height mm (in.) | 1808 (71.2) | (min.) [†] | |
| | 1875 (73.8) | (max.) [†] | |

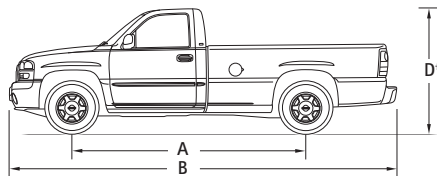

REGULAR CAB LONG BOX

| | | | |
|------------------------------------|--------------|------------------------|--------------------|
| A Wheelbase mm (in.) | 3378 (133.0) | | |
| B Overall Length** mm (in.) | 5702 (224.5) | 1500 model | |
| | 5641 (222.1) | 1500HD and 3500 models | |
| C Width mm (in.) | 2024 (79.7) | (max.)* | Single Rear Wheels |
| | 2441 (96.1) | (max.)* | Dual Rear Wheels |
| D Height mm (in.) | 1803 (71.0) | (min.) [†] | |
| | 1935 (76.2) | (max.) [†] | |

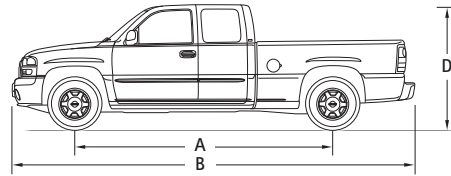

EXTENDED CAB STANDARD BOX

| | | | |
|------------------------------------|--------------|---------------------|----------------------------|
| A Wheelbase mm (in.) | 3645 (143.5) | | |
| B Overall Length** mm (in.) | 5847 (230.2) | 1500 model | |
| | 5784 (227.7) | 2500HD model | |
| C Width mm (in.) | 2024 (79.7) | (max.)* | Single Rear Wheels |
| | 2121 (83.5) | (max.)* | Quadrateer equipped models |
| D Height mm (in.) | 1808 (71.2) | (min.) [†] | |
| | 1938 (76.3) | (max.) [†] | |

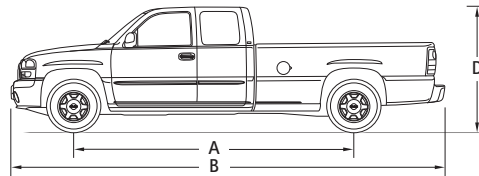

EXTENDED CAB LONG BOX

| | | | |
|------------------------------------|--------------|------------------------|--------------------|
| A Wheelbase mm (in.) | 4001 (157.5) | | |
| B Overall Length** mm (in.) | 6325 (249.0) | 1500 model | |
| | 6264 (246.6) | 2500HD and 3500 models | |
| C Width mm (in.) | 2024 (79.7) | (max.)* | Single Rear Wheels |
| | 2441 (96.1) | (max.)* | Dual Rear Wheels |
| D Height mm (in.) | 1798 (70.8) | (min.) [†] | |
| | 1933 (76.3) | (max.) [†] | |

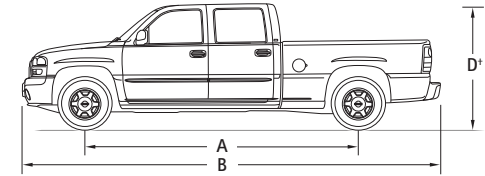

CREW CAB SHORT/STANDARD BOX

| | | | |
|------------------------------------|--------------|------------------------------|----------------------------|
| A Wheelbase mm (in.) | 3645 (143.5) | 1500 Crew Cab Short Box | |
| | 3886 (153.0) | 1500HD Crew Cab Standard Box | |
| B Overall Length** mm (in.) | 5738 (225.9) | 1500 Crew Cab Short Box | |
| | 6025 (237.2) | 1500HD Crew Cab Standard Box | |
| C Width mm (in.) | 2024 (79.7) | (max.)* | Single Rear Wheels |
| | 2121 (83.5) | (max.)* | Quadrateer equipped models |
| D Height mm (in.) | 1956 (77.0) | (min.) [†] | |
| | 1935 (76.2) | (max.) [†] | |

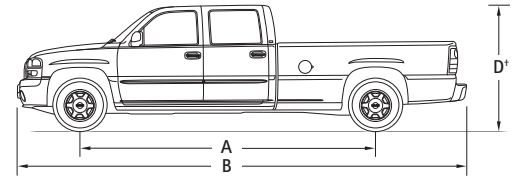

CREW CAB LONG BOX

| | | | |
|------------------------------------|--------------|---------------------|--------------------|
| A Wheelbase mm (in.) | 4242 (167.0) | | |
| B Overall Length** mm (in.) | 6505 (256.1) | | |
| C Width mm (in.) | 2024 (79.7) | (max.)* | Single Rear Wheels |
| | 2441 (96.1) | (max.)* | Dual Rear Wheels |
| D Height mm (in.) | 1963 (77.3) | (max.) [†] | |

*Excluding mirrors. †Depending on model selected. **Measured without rear bumper. †Depending on model selected.

SAFETY AND SECURITY

| | SL | SLE | SLT |
|--|----|-----|-----|
| Air bags – dual-stage, driver and front-passenger, frontal. Includes Passenger Sensing System with automatic air bag suppression (1500 models only) | S | S | S |
| Air bags – single-stage, driver and front-passenger, frontal (1500HD models only) | – | S | S |
| Brake/transmission shift interlock – (automatic transmission only) | S | S | S |
| Door locks – power, with lock-out protection | 0 | S | S |
| Headlights – Daytime Running Lights with automatic light control | S | S | S |
| Keyless entry system – remote, programmable with Panic alarm feature | – | S | S |
| OnStar In-Vehicle Communications and Assistance Service – includes one-year Safe & Sound Plan | – | 0 | S |
| Safety restraints – LATCH (Lower Anchors and top Tethers for Children) – Ext. and Crew Cab only | S | S | S |
| Theft-deterrent system – PASSLock | S | S | S |
| Traction assist – electronic, 2WD models ¹ | 0 | 0 | 0 |

¹ Availability varies based on equipment.

MECHANICAL

| | SL | SLE | SLT |
|--|----|-----|-----|
| Brakes – power, front disc/rear drum with anti-lock braking system (ABS) | S | S | S |
| Brakes – power, 4-wheel disc with anti-lock braking system (ABS) on models with available QuadraSteer, 1500HD, Denali and Hybrid models | – | S | S |
| Engines – refer to page 17 for complete availability | S | S | S |
| Engine block heater | S | S | S |
| Exhaust system – aluminized stainless steel muffler and tailpipe | S | S | S |
| Locking differential – rear (standard on SLE and SLT 4x4s) | 0 | 0 | 0 |
| QuadraSteer – 4-wheel steering with mode selector switch on instrument panel, roof marker lights, special rear flared fenders with marker lights, limited-slip differential and Ride Control suspension ² (see page 19 for details) | – | 0 | 0 |
| Spare tire carrier – rear underbody, winch-mounted, includes lock | S | S | S |
| Steering – power, rack-and-pinion on 1500 Series 2WD models | S | S | S |
| Steering – power, recirculating ball on all other models | S | S | S |
| Tires – 17" wheels with sizes ranging from P245/70R17 up to P265/70R17 all-season blackwalls (except Hybrid models) | S | S | S |
| Tires – 16" wheels with LT245/75R16 all-season blackwalls on 1500HD Crew Cabs | – | S | S |
| Trailer Special Equipment Package – includes weight-distributing platform trailer hitch receiver, 8-lead wiring harness with a 7-way sealed connector (includes 7-pin to 4-pin adapter and trailer brake control wiring harness), heavy-duty transmission cooler and high capacity air cleaner (std. on Denali) | 0 | 0 | 0 |
| Transfer case – lever operated, 2-speed manual (4x4 models) | S | S | – |
| Transfer case – Autotrac with electronic push-button controls, standard on Crew Cab (4x4 models) | – | 0 | S |
| Transmission – 5-speed manual with overdrive (SL Regular Cab Standard Box only) | S | – | – |
| Transmission – 4-speed automatic with overdrive and Tow/Haul mode | S | S | S |

² Available on 1500 Extended Cab short box 4x4 and 1500HD Crew Cab models.

EXTERIOR

| | SL | SLE | SLT |
|--|----|-----|-----|
| Box side rail protector ³ (NA with QuadraSteer) | 0 | 0 | 0 |
| Box – Fleetside Short (5 ft. 8.5 in.) – 1500 Crew Cab only | – | S | S |
| Box – Fleetside Standard (6 ft. 6 in.) – 1500HD Crew Cab | – | S | S |
| Box – Fleetside Standard (6 ft. 6 in.) or Long (8.0 ft.) – 1500 Reg. and Ext Cab ⁴ | S | S | S |
| Box – Sportside (6 ft. 6 in.) – Reg. or Ext. Cab only | 0 | 0 | 0 |
| Bumpers – front, chrome with spectra gray cover and air dam | S | S | S |
| Bumpers – rear chrome with step pad | S | S | S |

³ Dealer installed accessory. ⁴ Specify box size when ordering.

EXTERIOR (cont'd)

| | SL | SLE | SLT |
|---|----|-----|-----|
| Fender flares – wheel-opening, standard on Crew Cab ⁵ (4x4 models) | 0 | 0 | 0 |
| Fog lights | – | 0 | S |
| Glass – Solar-Ray tinted, all windows | S | S | S |
| Glass – deep-tinted on all windows behind front doors | 0 | 0 | S |
| Grille – moulded plastic, painted argent with chrome surround | S | S | S |
| Mirrors – below eye-line, foldaway, black | S | S | S |
| Mirrors – power remote control, heated | – | S | – |
| Mirrors – power remote control, heated, power folding with reverse down, auto-dimming electrochromic driver's side and integral turn signals | – | 0 | S |
| Mirrors – camper-style, power remote control, heated, power extend and integral turn signals ⁶ (NA Crew Cab) | – | 0 | 0 |
| Mirrors – camper-style, manual extend | 0 | – | – |
| Mouldings – bodyside, black | 0 | – | – |
| Mouldings – bodyside, chrome | – | S | S |
| Pickup box tonneau cover – soft or hard cover design ³ | 0 | 0 | 0 |
| Running boards – black, contoured ³ (NA with Crew Cab) | 0 | 0 | 0 |
| Side assist steps – tubular design, black or chrome finish ³ | 0 | 0 | 0 |
| Skid plates – off-road, included with 1500 Z71 suspension (4x4 only) | 0 | 0 | 0 |
| Tow hooks – two front (all models) | S | S | S |
| Wheel trim – please refer to page 30 for description and availability | S | S | S |

⁵ Not available with Sportside Box or QuadraSteer.

⁶ Not available with QuadraSteer or 1500 Crew Cab models.

INTERIOR

| | SL | SLE | SLT |
|---|----|-----|-----|
| Air conditioning – dual-zone, manual climate control (standard on SL Ext. Cab) | 0 | S | – |
| Air conditioning – dual-zone, automatic climate control | – | 0 | S |
| Console – mini overhead | – | S | S |
| Cruise control – electronic with resume, coast and decelerate/accelerate features | 0 | S | S |
| Cupholders | S | S | S |
| Defogger – electric, rear-window | 0 | S | S |
| Door trim panels – colour-keyed grained moulded plastic | S | – | – |
| Door trim panels – soft vinyl with carpet-covered map pocket | – | S | S |
| Driver Information Centre – includes multi-language with trip functions, displays vital vehicle functions with both visual and audible reminders/warnings | S | S | S |
| Floor covering – black vinyl (NA with Crew Cab) | S | 0 | – |
| Floor covering – colour-keyed carpeting and removable vinyl floor mats (includes rear in Ext. and Crew Cabs) | 0 | S | S |
| Instrumentation – full analogue design including speedometer, tachometer, voltmeter, coolant temperature, oil pressure, fuel gauge, odometer, trip odometer and engine hour meter | S | S | S |
| Mirror – rear-view, auto-dimming electrochromic with compass and exterior temperature readouts | – | S | S |
| Personalization feature – programs many comfort and convenience features using the steering wheel controls, including automatic locking/unlocking, seat position recall, perimeter lighting, exit lighting, remote lock/unlock feedback and reverse-tilt of exterior mirrors | – | – | S |
| Power outlet – one auxiliary, 12-volt, in addition to cigarette lighter receptacle | S | S | S |
| Smoker's Package – includes lighter and ashtray (standard with bench seating) | S | 0 | 0 |
| Steering column – tilt adjustable | S | S | S |
| Steering wheel – leather-wrapped | – | S | S |
| Stowage box – under rear seat ⁴ (Ext. Cab only) | 0 | 0 | 0 |

| INTERIOR (cont'd) | SL | SLE | SLT |
|--|----|-----|-----|
| Sunroof – power, with express-open and wind deflector ⁷ | – | 0 | 0 |
| Sunshades – LH and RH padded colour-keyed cloth; LH with pocket, RH with visor mirror | S | S | S |
| Windows – power, driver's express-down and lock-out feature | – | S | S |
| Windows – rear, manual sliding ⁸ | 0 | 0 | 0 |

⁷ Available on Ext. and Crew Cab models only. Requires optional bucket seats on SLE models. Includes HomeLink transmitter.

⁸ Deletes rear-window defogger.

| SEATS | SL | SLE | SLT |
|---|----|-----|-----|
| Front 40/20/40 split-bench seat with manual driver's side recliner, in vinyl or cloth trim (Reg. Cab) | S | – | – |
| Front, Custom cloth 40/20/40 split-bench with manual recliners and centre armrest/storage – Ext. and Crew Cab also include seatback storage pockets | – | S | – |
| High-back front bucket seats with manual recliners, power 6-way driver seat adjuster, driver and front-passenger inboard armrests – includes seatback storage pockets and centre floor console – Custom cloth or leather seat inserts (NA in Reg. Cab) | – | 0 | – |
| Full-feature front high-back bucket seats with heated leather seat inserts, driver's side 2-position memory controls and power 10-way driver and front-passenger seat adjusters including power lumbar supports, seatback recliners and bolsters – includes driver and front-passenger inboard armrests, seatback storage pockets and floor console | – | – | S |
| Power 6-way driver seat adjuster on 40/20/40 split-bench seat | – | 0 | – |
| Rear fold-up seat in Extended Cab ⁹ | S | S | S |
| Rear 40/60 split fold-down seat in Crew Cab ⁹ | – | S | S |
| Leather front seat inserts – Extended and Crew Cab | – | 0 | S |
| Head restraints, adjustable on all outboard seats | S | S | S |

⁹ Rear seats are vinyl in SLT models and SLE models with optional leather seat inserts.

| ENTERTAINMENT SYSTEMS | SL | SLE | SLT |
|---|-----------------|-----|-----|
| AM/FM stereo with seek/scan, digital clock and 4 speakers | S | – | – |
| AM/FM stereo with seek/scan, CD player, Radio Data System (RDS), auto tone control, digital clock and 6 speakers | 0 ¹⁰ | S | – |
| Same as above with both cassette tape and CD players (includes 6 premium Bose speakers with optional bucket seats) | – | 0 | 0 |
| AM/FM stereo with seek/scan, 6-disc CD changer, Radio Data System (RDS), auto tone control, digital clock and 6 Bose premium speakers | – | 0 | S |
| Steering wheel audio controls | – | 0 | S |
| Rear-seat audio controls (Crew Cab) | – | S | S |
| DVD Entertainment Package – includes rear seat overhead fold-down 178 mm (7 in.) LCD colour monitor, DVD player, video camera and video game input (RCA) jacks, rear-seat audio controls and 2 sets of wireless headphones (Crew Cab) | – | 0 | 0 |

¹⁰ Includes 4 speakers in SL models.

| SUSPENSION PACKAGES | SL | SLE | SLT |
|--|----|-----|-----|
| 2-WHEEL DRIVE AND 4X4 | | | |
| Standard suspension , includes twin tube 32 mm shock absorbers – 2WD Regular and Extended Cabs only | S | S | – |
| Heavy-duty , includes monotube 36 mm shock absorbers. Provides increased damping to improve handling and trailering (standard on all other models) | S | S | S |
| Ride Control , includes 46 mm shock absorbers with adjustable electronic suspension (except Crew Cab) | – | 0 | 0 |
| 4x4 ONLY | | | |
| Off-Road , includes monotube 46 mm shock absorbers, off-road jounce bumpers and stabilizer bars, high-capacity air cleaner, skid plates (shields for engine, transmission, front differential and transfer case), special removable air dam and Z71 decals (except 1500HD Crew Cab) | – | 0 | 0 |

S – Standard. 0 – Optional individually or in combination with other optional equipment.

NOTE: The trim features indicated reflect only a portion of the content of the Sierra 1500 models. For a complete list, details and information on other Sierra models, please see your Sales Consultant.

SIERRA 1500 PREFERRED EQUIPMENT GROUPS

Shown below are the Preferred Equipment Groups (PEGs) available on Sierra 1500. PEGs are packages of popular options that have been assembled to add value and make ordering easier. PEGs are subject to change without notice. Please note that features included in PEGs are not always available as individual options. For more information on Preferred Equipment Groups, please see your Sales Consultant

- The first upgrade adds the following features to the SL models:
 - Air conditioning is added to Regular Cab models – Carpeted floor covering and vinyl floor mats – Grille with chrome surround
 - Black bodyside mouldings – Rear locking differential (4x4 models) – Chrome-styled wheels with chrome centre caps
- You can further upgrade the SL model by adding these convenience features to the above:
 - Cruise control – Power door locks – CD player
- You can also upgrade the SLE Regular and Extended Cab models to include these features:
 - Fog lights – Deep-tinted glass on all windows behind front doors – Autotrac 4x4 system (on 4x4 models – standard on Crew Cab) – 17" aluminum wheels

SIERRA DENALI CREW CAB

Below are some of the standard features that make the 1500 Sierra Denali Crew Cab such an outstanding vehicle.

Mechanical

– Engine: 345 hp Vortec 6000 V8 – Transmission: Heavy-duty 4-speed automatic – Drivetrain: Full-time all-wheel drive (AWD) – Locking rear differential – Tires: P265/70R17 all-season blackwall– Trailering Special Equipment Package

Exterior

– Bumpers: Colour-keyed front and rear – Exhaust tip: Chrome plated – Grille: Special chrome design – Mirrors: Heated and power-adjustable, with colour accents, power folding with curb-view assist, integral turn signal indicators and puddle lights, driver's side electrochromic auto-dimming – Mouldings: Deluxe bodyside – Side steps: Full-length tubular, chrome – Wheels: Specific 17" aluminum

Interior

– Air Conditioning: Dual-zone automatic climate control – Driver Information Centre – Carpeting: Front and rear with carpeted floor mats – Personalization feature – Rear-seat audio controls and headphone jacks – Sound system: AM/FM stereo with seek/scan, cassette tape player, 6-disc in-dash CD changer, auto tone control, AudioPilot noise-compensated volume control, digital clock and 6 premium Bose speakers – Steering wheel sound system controls – Seats: Full-feature high-back reclining front buckets with heated leather seat inserts and 10-way power seat adjusters – Sunshades: With illuminated visor mirrors – Transmitter: Universal HomeLink 3-channel

SPECIAL APPEARANCE PACKAGES

SL Regular or Extended Cab models with Fleetside or Sportside* Box:

- Custom cloth seats
- Z85 heavy-duty suspension (standard on 4x4)
- 17" 6-spoke aluminum wheels
- Deep-tinted glass on all windows behind front doors
- Locking rear differential (standard on 4x4)
- Chromed stainless steel tubular running boards

SLE Regular, Extended or Crew Cab model with Fleetside or Sportside* Box:

- Z85 heavy-duty suspension (standard 4x4 and Crew Cab models)
- 17" 6-spoke aluminum wheels
- Deep-tinted glass on all windows behind front doors
- Fog lights
- Locking rear differential (standard on 4x4)
- Autotrac 4x4 transfer case (standard on Crew Cab 4x4)
- Chromed stainless steel tubular running boards

*Available with Regular or Extended Cab only.

VORTEC 5300 V8 HAULER PACKAGES

SLE Regular and SLE/SLT Extended Cab 2WD models with Fleetside Standard or Long Box:

- Vortec 5300 V8 with 295 hp**
- Trailering Special Equipment Package
- Locking rear differential
- ZX3 Ride Control suspension

SLE/SLT Crew Cab 2WD models with Fleetside Short Box:

- Trailering Special Equipment Package
- Locking rear differential

VORTEC 5300 V8 OFF-ROAD PACKAGES

You can add the following to your Sierra 1500: SLE Regular and SLE/SLT Extended Cab 4x4 models with Fleetside Standard or Long Box:

- Vortec 5300 V8 with 295 hp**
- Trailering Special Equipment Package
- Z71 Off-Road Suspension Package (see suspension packages for details)
- Autotrac 4x4 transfer case (standard in SLT and up-level SLE Extended Cab models)

SLE/SLT Crew Cab 4x4 models with Fleetside Short Box:

- Trailering Special Equipment Package
- Z71 Off-Road Suspension Package (see suspension packages for details)

**Standard in SLE Extended Cab Long Box and SLT models. Extended Cab models feature the aluminum block Vortec 5300 V8 with 310 hp.

WHEELS. FABRICS. CHOICES.

Sierra Wheels

1500 Series

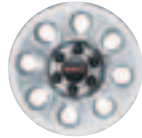

17" x 7.5"
Steel with cap,
painted silver.
Standard on SL.

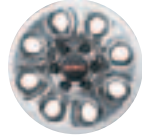

17" x 7.5"
Chrome styled with
chrome-cap. Standard
on SLE, available on SL.



17" x 7.5"
6-Spoke aluminum.
Available on
SLE and SLT.



17" x 7.5"
Deluxe aluminum
Standard on SLT.

Sierra Denali



17" x 7.5"
Aluminum
Standard on Denali.



20" x 8.5"
Chromed aluminum.
Available on Denali
(interim availability)

1500HD/2500HD Series



16" x 6.5"
Steel with cap,
painted silver.
Standard on 2500 HD SL.

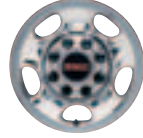

16" x 6.5"
Chrome-styled
with chrome cap.
Standard on 2500HD SLE,
available on SL.

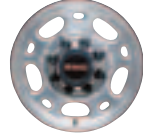

16" x 6.5"
Polished aluminum.
Standard on 1500HD models and
2500HD SLT. Available on 2500HD
SL and SLE.

3500 Series Dual Rear Wheel

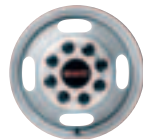

16" x 6.5"
Steel with cap, painted silver.
Standard on SL.

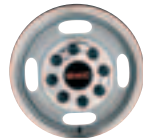

16" x 6.5"
Steel, painted silver with
chrome trim rings and cap.
Standard on SLE and SLT.
Available on SL.

3500 Series Single Rear Wheel



16" x 6.5"
Steel with cap, painted silver.
Standard on SL.
Chrome centre cap on SLE and SLT.

Sierra Interior Fabrics

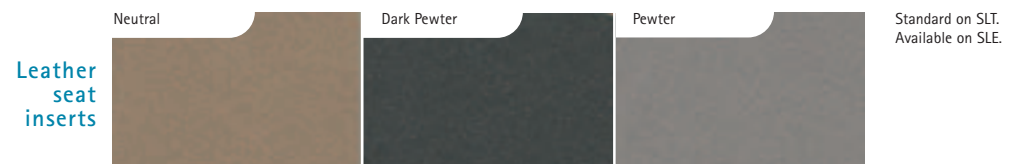
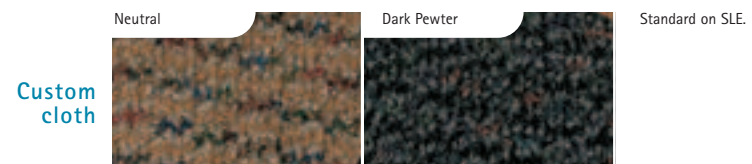
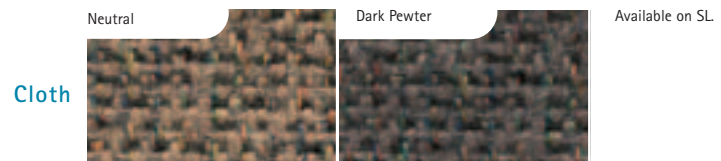
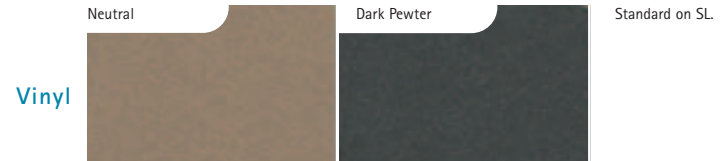

A word about this brochure

Some of the equipment shown or described throughout this brochure may be available at extra cost. We have tried to make this brochure comprehensive and factual. We reserve the right, however, to make changes at any time, without notice, in prices, colours, materials, equipment, specifications, models and availability. Specifications, dimensions, measurements, ratings and other numbers in this brochure and other printed materials provided at the dealership or affixed to vehicles are approximates based upon design and engineering drawings and prototypes and laboratory tests. Your vehicle may differ due to variations in manufacture and equipment. Since some information may have been updated since the time of printing, please check with your GMC dealer for complete details. General Motors of Canada Limited reserves the right to lengthen or shorten the model year for any product for any reason, or to start and end model years at different times.

Privacy Statement

At General Motors of Canada Limited ("GM Canada") we respect your privacy and value our relationship with you. Your personal information will be protected, will never be sold, and will be used only by GM Canada, our affiliates, dealers/retailers, and service suppliers (only to provide services). If you wish to be removed from GM Canada marketing communications; would like to limit only certain marketing communications from us; would like a listing of our specific uses or further information about those with whom your information is shared; or for further information about our Privacy Policy and practices, please contact us at 1-800-GM-DRIVE (1-800-463-7483) or through our Web site at www.gmc.ca

A word about assembly

GMC Trucks are equipped with engines and components produced and assembled by different operating units of General Motors, its subsidiaries and suppliers and these engines and components may change or be obtained from different sources from time to time. All such engines and components are approved for use in GMC Trucks. Certain equipment ordered may be unavailable at the time of assembly and we suggest that you verify that your vehicle includes the equipment you ordered, or if there are changes, that they are acceptable to you.

Trademark

The marks appearing in this Sierra brochure including, but not limited to: General Motors, GM, the GM Canada emblem, the GM Canada Web site address, the GM Accessories logo, GMC, the GMC logo, Canyon, Denali, Envoy, Jimmy, Safari, Savana, Sierra, Yukon and their respective logos, emblems, slogans and vehicle model names and body designs; and other marks such as Z71, Autotrac, ACDelco, Duramax, PASSLock, SMARTLEASE, Solar-Ray, TOTAL Warranty and Vortec are all trademarks of General Motors Corporation and/or General Motors of Canada Limited, its subsidiaries, affiliates or licensors.

GMAC is a registered trademark of the General Motors Acceptance Corporation.
OnStar, the OnStar logo and the OnStar button are registered trademarks of the OnStar Corporation.
QuadraSteer and TheftLock are registered trademarks of Delphi Automotive Systems.
Bose and AudioPilot are registered trademarks of the Bose Corporation.
HomeLink is a registered trademark of the Prince Corporation.
Radio Data System (RDS) is a registered trademark of the U.S. National Association of Broadcasters.

Copyright

© Copyright 2004 General Motors of Canada Limited. All Rights Reserved. All text, images, graphics, and other materials in this Sierra brochure are subject to the copyright and other intellectual property rights of General Motors Corporation and/or General Motors of Canada Limited. These materials may not be reproduced, distributed or modified without the express written permission of General Motors Corporation and/or General Motors of Canada Limited.

COLOURS. BRILLIANT COLOURS.

Sierra Exterior Colours



15 Sand Beige Metallic



25 Deep Blue Metallic



41 Onyx Black



47 Polo Green Metallic



50 Summit White



59 Silver Birch Metallic



62 Carbon Metallic



63 Sport Red Metallic



74 Fire Red

Conventional two-tone (ZY2) places the Silver Birch Metallic accent colour below the lower styling line. Only available on SLE and SLT 1500 models. Not available with Quadrateer or Sportside box.



25 Deep Blue Metallic

59 Silver Birch Metallic

Buyer's guide

Colours may not be exactly as illustrated due to restrictions of the printing process. Please see your Sales Consultant for specific colour and model availability and compatibility.



05 SIERRA

CANYON

SIERRA

JIMMY

ENVOY

YUKON

SAFARI

SAVANA

05 SIERRA

AT GMC, we set the highest possible standards for ourselves and our vehicles. Only the best is good enough – and only until we find a way to make it even better. This relentless pursuit of improvement has been going on for over a century now, and for 2005, it's resulted in the finest line of pickups, vans and SUVs we've ever built. If you believe, as we do, in only settling for the best, one of them could be for you.

THE GM COMMITMENT

Legendary engineering, quality and capability are only part of the GMC ownership experience. As a GMC owner, you also enjoy General Motors of Canada's commitment to your satisfaction. GM has created a wide range of programs to increase your enjoyment of your new vehicle. Some of these programs make it easier for you to obtain the GMC vehicle of your choice. Others enhance the ownership experience over the long term. Information on many of these programs is provided below.

THE GM TOTAL™ Warranty:†

The GM TOTAL™ Warranty is your promise of total warranty protection. It covers every new GMC Sierra for 3 years or 60,000 km.* Complete vehicle repairs are covered,** including parts and labour, with no deductible. The warranty also includes:

- 3-year/60,000 km* complete vehicle repair coverage
- 5-year/160,000 km* corrosion perforation coverage
- 8-year/130,000 km* coverage on catalytic converters and powertrain control modules (PCMs)

*Whichever comes first. **To correct any defects in material or workmanship occurring during the warranty period. Regular maintenance is not included, nor is excessive wear and tear caused by reckless or negligent driving.

OTHER OWNERSHIP PRIVILEGES AND PROGRAMS:†

- Roadside Assistance – 24/7 service via toll-free number during your warranty period, anywhere in Canada or the United States
- Courtesy Transportation – may be offered during warranty period
- GM Protection Plan (GMPP) – The only extended service contract backed by the resources and commitment of General Motors. GMPP may be purchased at the time of your sale or lease, or subsequently
- GM Mobility Program – You may be eligible for reimbursement of up to \$1000 (taxes included) for adaptive equipment for your GM vehicle
- GM Accessories – Personalize your vehicle with GM Accessories specifically engineered for your new GM vehicle
- GM Goodwrench Service – With GM-certified technicians and GM-approved parts, nobody knows your GM vehicle better

TO HELP YOU PURCHASE OR LEASE A NEW VEHICLE:

- GMAC Financing – on-the-spot financing at your GM dealership††
- GMAC SMARTLEASE – a smart alternative to traditional financing††
- GM Graduate Program – recent graduates may qualify for up to \$1000 (taxes included) off any new GM vehicle‡
- The GM Card – Eligible cardholders may be able to redeem up to \$3500 in GM Card® Earnings toward the total purchase price or lease down payment on selected vehicles. For more information on The GM Card please call 1-800-461-3279.†

INFORMATION RESOURCES:

You can find more information about these programs from your GM dealer, or at these information centres:

- The GM Web site at gmcanada.com
- The GM Customer Communication Marketing Centre at 1-800-GM-DRIVE (1-800-463-7483 or 1-800-263-3830 for TDD users) – for information about any GM product or service, including The GM Card and the GM Mobility Program
- For information about GMAC visit the GM Web site or call 1-800-616-4622.

†Conditions and limitations apply. ††Subject to eligibility.

