

05 YUKON





The strength of experience.

It's almost seventy years now since a few adventurous engineers at GMC bolted a station wagon-style body onto a pickup truck frame to create the company's first SUV, the Suburban Carryall. How things have changed. Today's Yukon, Yukon Denali, Yukon XL and Yukon XL Denali – the Suburban Carryall's direct descendants – deliver a combination of capability and comfort that would have astounded those early SUV owners. And that's only part of their appeal. With their range of Vortec engines, today's Yukons also offer superb performance. They're surprisingly agile, too, especially when equipped with advanced chassis systems like StabiliTrak and the segment-exclusive QuadraSteer four-wheel steering system. And for 2005, the added convenience and security of OnStar is standard on every model. The highly evolved 2005 Yukons. They're the latest in a long line of legendary full-size GMC SUVs.





YUKON SLT, shown in Sport Red Metallic.

05 **YUKON**



YUKON. AN SUV YOU'LL FEEL GOOD ABOUT.

FROM THE MOMENT you take your place in the driver's seat of your new GMC Yukon, you'll experience a rare sense of well-being – a product of this vehicle's impressive substance and confidence-inspiring four-season capabilities. Yukon's full-size presence and handsome, muscular style are hard to miss, especially with standard features like styled aluminum wheels and deep-tinted rear glass on all models. Yukon's performance is distinctive, too, thanks to a choice of three excellent Vortec V8 engines, including a bi-fuel Vortec 5300 V8 engineered to run on both gasoline and E85 (85% ethanol) fuel. You'll also appreciate Yukon's easy, agile handling – a remarkable characteristic in a vehicle in this class.



YUKON XL 1500, shown in Carbon Metallic.

05 **YUKON XL**



YUKON XL. FULL-SIZE – AND THEN SOME.

IN ADDITION TO THE VIRTUES of Yukon, Yukon XL adds more overall length, more wheelbase, more interior room – and an even higher level of versatility. Nine-passenger seating is standard equipment. Maximum cargo capacity is a whopping 3727 L (131.6 cu. ft.). And should you need to take even more gear along, Yukon XL 2500 is a superb tow vehicle, with trailering capacity as high as 5443 kg (12,000 lb.) when properly equipped. Put it all together and you've got one of the most capable vehicles in the world.



YUKON XL SLT interior, shown in Pewter with available front-seat side-impact air bags.

05 YUKON INTERIOR



YUKON AND YUKON XL. BIG ON COMFORT.

WITH THEIR GENEROUSLY PROPORTIONED INTERIORS and supportive seating for up to nine occupants, today's Yukons are among the most welcoming of SUVs. Every model offers standard features like tri-zone climate control and a quality audio system with both CD and cassette tape players that help to keep your passengers comfortable and entertained. For an even higher level of comfort, consider the many premium amenities that come standard on SLT models. Ten-way power adjustable front bucket seats and power adjustable pedals make it a simple matter to find just the right driving position, and power front-seat lumbar adjusters allow you to select just the right amount of back support for long-distance driving. Heated seats with leather seating surfaces, an in-dash 6-disc CD changer, second-row audio controls and a Bose Premium sound system are also standard on every SLT model.



YUKON instrument panel, shown with available equipment.

05 **YUKON CONTROL**

YUKON KEEPS YOU ENGAGED, INFORMED AND FIRMLY IN CHARGE.



FROM THE MOMENT you take the wheel of your new Yukon or Yukon XL, you'll feel you're comfortably in control. Visibility is excellent, thanks to Yukon's tall seating position, large heated exterior rear-view mirrors and Solar-Ray tinted glass all around. Clear analogue gauges provide the essential information you need, supplemented by additional data provided by the standard Driver Information Centre. All the controls function with an impeccable logic, and everything is where you expect it to be, with switches positioned for intuitive use, within easy reach of the steering wheel. There are even controls for the audio system and standard Driver Information Centre mounted on the wheel itself, so you can make adjustments without ever having to take your eyes off the road.

- a. The standard electrochromic interior rear-view mirror includes an 8-point compass, an exterior temperature display, a passenger-side air bag suppression status readout and OnStar controls.
- b. The standard AM/FM stereo system in Yukon and Yukon XL features a CD player, a cassette tape player, auto tone control and a Radio Data System (RDS).
- c. The standard Driver Information Centre monitors numerous vehicle functions. It can even alert you when there's a possibility of ice forming on the road.

HAVE IT YOUR WAY.



The available power glass sunroof brightens the interior. An express-open feature moves the glass panel to the full-open position with a single touch.

The available rear-seat DVD Entertainment System includes a 178 mm (7 in.) LCD screen, 2 sets of wireless infrared headphones and jacks to plug in video games.



Available power adjustable pedals help drivers of all sizes to find a comfortable position at the proper distance from the steering wheel. They're standard on Yukon SLT and Denali models.

A FEW CAREFULLY SELECTED OPTIONS can add enormously to your Yukon ownership experience. Popular available features include a glass sunroof and a roof-mounted DVD Entertainment System that will keep your rear passengers amused for hours.

05 YUKON AMENITIES

FOUR-SEASON COMFORT, CONTINENT-WIDE CONFIDENCE.



NO MATTER WHERE YOU WANT TO GO or what the weather is doing, a Yukon or Yukon XL is a superb travel companion. Yukon's powerful air conditioning system, standard rear heater and available heated front seats help to keep you and your passengers equally comfortable in the heat of summer and the chill of winter. Yukon and Yukon XL also offer an available DVD navigation system that can help you find your way, stress-free, to countless North American destinations.

Rear-seat audio controls allow second-row passengers to listen to their own sound source via headphones, independent of the main sound system. Included with the floor console in all models with front bucket seats.



- a. SLT and Denali models feature controls for the driver's seat memory function, power adjustable pedals and more, all conveniently positioned on the driver's door.
- b. Climate controls for the rear seating area are positioned in the overhead console. A second set of controls is located within reach of rear-seat passengers.
- c. Yukon SLT and Denali models offer an available DVD navigation system that can help you find your way to millions of destinations in Canada and the United States.*

*Detailed map coverage is provided for most major urban areas of the United States and certain metropolitan areas of Canada (Quebec City, Montreal, Ottawa, Toronto, London, Windsor, Edmonton, Calgary and Vancouver). Please speak with your sales consultant regarding Yukon's navigation system's geographic coverage.



YUKON XL DENALI, shown in Onyx Black with available 20-inch aluminum wheels (interim availability).

05 **YUKON DENALI**

YUKON DENALI AND YUKON XL DENALI. GMC'S BEST-PERFORMING, MOST LUXURIOUS FULL-SIZE SUVs.

FEW SUVs AT ANY PRICE HAVE WHAT IT TAKES to compete with Yukon Denali and Yukon XL Denali. In appearance, these handsome trucks define top-of-the-line, with their exclusive front and rear styling, monotone paint, polished 17-inch aluminum wheels and glittering projector-beam headlights. They're just as remarkable when it comes to technology. A 335-horsepower Vortec 6000 V8 is standard equipment, along with an advanced all-wheel-drive (AWD) system, an AutoRide Control suspension and the StabiliTrak stability enhancement system. There's also a standard heavy-duty trailering package that allows these premium trucks to tow up to an impressive 3674 kg (8100 lb.).



YUKON XL DENALI interior, shown in Sandstone with available second-row bucket seats.

05 YUKON DENALI INTERIOR



INSIDE DENALI, THE BEST OF EVERYTHING.

IF ROUGHING IT IS YOUR THING, you've come to the wrong place. Yukon Denali and Yukon XL Denali have the capability to take you far, far off the beaten path. But rest assured, the going will never be rough. Denali interiors feature heated ten-way power adjustable front bucket seats finished with supple leather seating surfaces.* The outboard second-row seat cushions and seatbacks are also heated, and your second-row passengers will enjoy a standard rear audio system that allows them to select their own sound source and listen to it with wireless infrared headphones. The Denali audio system also features an in-dash six-disc CD changer and a Bose Premium sound system with Bose AudioPilot® noise compensation technology so advanced, it will probably outperform the system you left at home.

*Third-row is vinyl.



YUKON DENALI, shown in Silver Birch Metallic.

05 PERFORMANCE

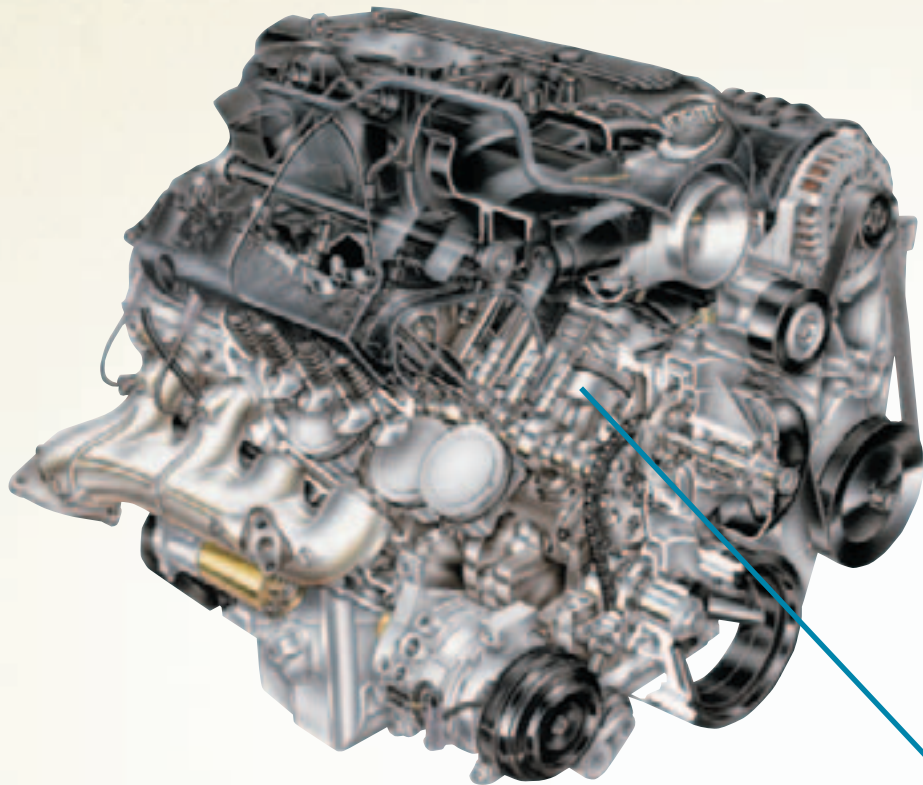

VORTEC. TODAY'S WORD FOR ABUNDANT, SMOOTH, RELIABLE POWER.

PEER UNDER THE HOOD of any 2005 Yukon and you'll find a Vortec V8 that's muscular, refined and satisfyingly fuel efficient. Choices range from Yukon's standard 285 horsepower Vortec 4800 V8 all the way up to the big-block Vortec 8100 V8. Available exclusively on Yukon XL 2500 models, it generates 440 pounds-feet of torque – the most of any gasoline engine in the class.* Paired with each of these engines is an electronically controlled four-speed automatic transmission that's equally sophisticated. Among its many intelligent features is a Tow/Haul mode, activated by a push button mounted on the transmission shifter, which provides improved driveability when you have a heavy load on board or a trailer in tow.

*Based on 2004 Model Year data for the GM Large Utility segment and latest published competitive information available at time of printing. Excludes other GM vehicles.

Vortec V8 engines are engineered to help keep maintenance costs down, with such long-life features as platinum-tipped spark plugs, DEX-Cool engine coolant, an oil life monitor and more.

YUKON ENGINE/TRANSMISSION* AVAILABILITY					
VORTEC ENGINES Horsepower @ rpm Torque lb.-ft. @ rpm	STANDARD GVWR kg (lb.)	VORTEC 4800 V8 285 @ 5200 295 @ 4000	VORTEC 5300 V8 295 @ 5200 335 @ 4000	VORTEC 6000 V8 335 @ 5200 375 @ 4000	VORTEC 8100 V8 320 @ 4200 440 @ 3200
1500 YUKON (1/2-TON)					
2WD	2948 (6500)**	S	0		
4x4	3084 (6800)**	S	0		
AWD Denali	3175 (7000)			S	
1500 YUKON XL (1/2-TON)					
2WD	3175 (7000)		S		
4x4	3266 (7200)		S		
AWD XL Denali	3266 (7200)			S	
2500 YUKON XL (3/4-TON)					
2WD	3900 (8600)			S ¹	0
4x4**	3900 (8600)			S ¹	0

S = Standard 0 = Optional

*All Yukons, Yukon XLs and Denalis are equipped with a 4-speed automatic transmission with overdrive. The 2500 Yukon XL models feature a heavy-duty automatic transmission.

**When the third-row seat is specified, the GVWR is increased to 3084 kg (6800 lb.) for 2WD models and 3130 kg (6900 lb.) for 4x4 models.

¹2500 Yukon XL with Vortec 6000 V8 produces 325 hp @ 5200 rpm and 365 lb.-ft. of torque @ 4000 rpm.



YUKON XL DENALI, shown in Onyx Black.

ENGINEERED TO TAKE ON YOUR WORLD.



Available on Yukon XL 2500, the amazing QuadraSteer four-wheel steering system represents a quantum leap in SUV handling. For more information, please refer to page 22.

IN TODAY'S YUKON AND YUKON XL, advanced technology pays off in real-world advantages. Take the frame, for example. Instead of being manufactured with conventional welded stampings, selected Yukon and Yukon XL frame components are shaped by water under extreme pressure, in a process called hydroforming. The result: strength without unnecessary fuel-robbing weight, along with a significant increase in dimensional accuracy and quality. Another example, consider the StabiliTrak vehicle stability enhancement system. It uses high-tech electronics to guard against potentially dangerous lateral skids. StabiliTrak is standard on Denali models and available on SLE and SLT (except 2500) models.

JOIN THE QUADRASTEER REVOLUTION.

After driving a Yukon XL 2500 equipped with the available QuadraSteer four-wheel steering system, *Automobile Magazine* was moved to write, "QuadraSteer is nothing short of a miracle."* Here's why. At highway speeds, the rear wheels of a QuadraSteer-equipped Yukon XL steer in the same direction as the front ones, resulting in significantly increased stability, even in crosswinds. At low speeds, though, the rear wheels steer opposite to the front wheels. That translates into unmatched low-speed manoeuvrability for this class of vehicle, with a turning circle comparable to that of a mid-size car. It also makes backing up with a trailer in tow easier than you could have believed possible. Add it all together and you have a genuine breakthrough in SUV handling.

*Source: Automobile Magazine, automobilemag.com

05 **QUADRASTEER**

FULL-SIZE SUVs FOR FULL-SCALE TOWING.



EQUIPPED WITH THE AVAILABLE TRAILERING SPECIAL EQUIPMENT PACKAGE AND POWER EXTENDING REAR-VIEW CAMPER MIRRORS, your Yukon or Yukon XL is one of the world's premier tow vehicles. Towing capacities range all the way up to 5443 kg (12,000 lb.) for Yukon XL 2500 models, and performance is excellent, even with a full load hooked up, thanks to the abundant torque provided by every standard and available Vortec V8 engine.



- a. The available power camper mirrors also feature integral heaters, power adjustments and in-glass turn signals.
- b. Properly equipped, Yukon XL 2500 can out-tow every other full-size SUV by a significant margin.*
*Based on 2004 Model Year data for GM Large Utility segment and latest published competitive information available at time of printing. Excludes other GM vehicles.
- c. The automatic transmission's Tow/Haul mode feature lets you summon up an even higher level of performance when you need it most.



YUKON DENALI, shown in Black with available 20-inch aluminum wheels (interim availability).

05 SAFETY & SECURITY

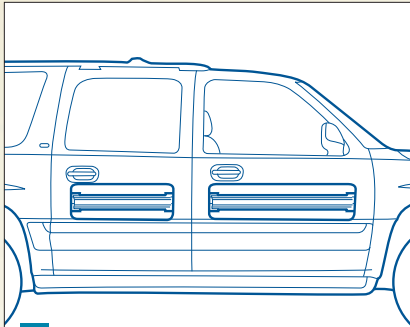

a

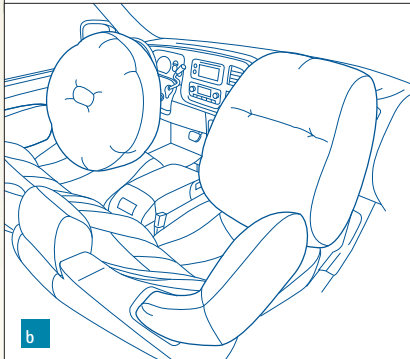

b

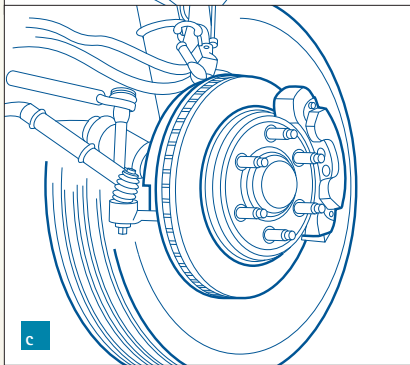

c

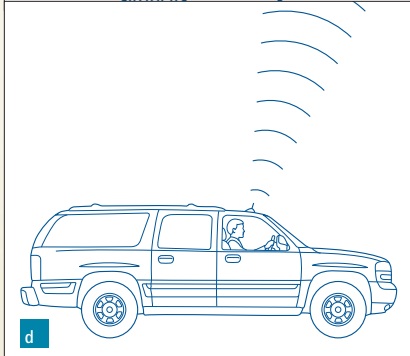

d

A POWERFUL PROTECTOR.

A CONCERN FOR SAFETY AND SECURITY is one of the top reasons why many drivers are attracted to full-size SUVs. It only makes sense, then, that Yukon and Yukon XL are loaded with features designed for your protection. The excellent visibility that you enjoy from Yukon's tall seating position helps you to avoid potentially dangerous situations, as do Yukon's surprisingly agile handling and powerful, ABS-equipped disc brakes. If the worst does occur, your Yukon will help protect you and your passengers from injury with features like crush zones, safety-cage construction, dual-stage frontal air bags* and available front seat-mounted side-impact air bags.

*A NOTE ON CHILD SAFETY: Always use safety belts and proper child restraints, even in vehicles equipped with air bags. Children are safer when properly secured in a rear seat. Never place a rear-facing infant restraint in the front seat of any vehicle equipped with an active air bag. Refer to the vehicle Owner's Manual and child safety seat instructions for more information. Air bag inflation can cause severe injury or death to anyone too close to the air bag when it deploys. Be sure every occupant is properly restrained.

- a. Every Yukon and Yukon XL side door contains a sturdy steel beam that helps keep objects from entering the passenger compartment in a side impact.
- b. The standard dual-stage frontal air bags deploy with reduced intensity in less severe impacts, while the front-passenger sensing system turns off the air bag if the seat is empty, contains a child seat or a small occupant.
- c. Yukon's stopping abilities are enhanced by 4-wheel disc brakes equipped with a dynamic rear proportioning system and standard ABS.
- d. Thanks to advanced GPS technology, OnStar advisors always know exactly where you are, even when you don't.



A General Motors Subsidiary

Always there. Always ready.

For over a century, GMC has advanced the state of the art in trucks by the intelligent application of technology. Case in point: OnStar. OnStar uses advanced communications technology to enhance your peace of mind whenever you're in your GMC Truck. All it takes is the touch of a single OnStar button inside your vehicle to connect you with one of our Advisors at the OnStar Centre.* They are standing by, ready to provide support 24 hours a day, 365 days a year.

What can OnStar Advisors do for you? They not only provide information and a range of other direct assistance services – but also, in an emergency, they will contact emergency service providers. And if air bags are deployed in your vehicle, an Advisor will contact you to determine if you need assistance. Your Advisor can also perform a remote diagnostic check of your engine and the electrical components in your vehicle.

Another convenient feature is OnStar Personal Calling,** which uses a button to activate the hands-free, voice-activated wireless phone that's integrated into your vehicle. It's there just in case your hand-held cellphone is lost, forgotten or has a low battery. Even better, there are no additional monthly system access fees, or additional long distance and roaming charges. And as a new customer, you will receive 30 trial minutes.

Knowing you have OnStar on board provides a powerful sense of added security. Just ask the more than 100,000 people who have become OnStar subscribers in Canada. How hard does OnStar work for you? The facts speak for themselves: every month in Canada OnStar Advisors handle an average of 7100 routing calls, 2000 emergency calls, 1900 door unlocks, and 1050 Roadside Assistance dispatches.

The OnStar System with one year of the Safe & Sound Plan is standard on all Yukon models. OnStar also offers the available Directions & Connections plan that provides route information, as well as a host of other convenience services. See your dealer for more details about the plans for Yukon.

*Subscription Agreement necessary. OnStar services require vehicle electrical system and wireless service to be available and operating for features to function properly. OnStar relies on existing emergency service providers as well as wireless and satellite technologies and is subject to their limitations. Call 1-888-4ONSTAR (1-888-466-7827), see your OnStar Owner's Guide, or visit www.onstarcanada.com for system information and details.

**Requires OnStar Personal Calling-enabled vehicle, existing OnStar service contract and prepaid calling minutes. OnStar voice recognition system may not recognize all voices. Available in most markets.



05 ACCESSORIES



MAKE YOUR YUKON AS INDIVIDUAL AS YOU ARE.



GM Accessories for Yukon/Yukon XL include:

- Hood protector
- Roof rack
- Splash guards
- Roof-mounted ski carrier
- Cargo organizer
- Rear air deflector
- All-weather floor mats
- Cargo area liner
- Trailer hitch package.



Genuine GM Accessories let you take the styling and functionality of your new Yukon or Yukon XL to an even higher level. They are the only accessories that are integrated into the process of designing your vehicle, ensuring excellent fit, finish and functionality. And only GM Accessories are backed by GM's 3-year/60,000 km TOTAL™ Warranty.* They can also be included in your new-vehicle lease or finance agreement through GMAC. Ask your dealer for a complete list of the GM Accessories available for Yukon and Yukon XL, or visit gmcanada.com

*Whichever comes first, when permanently installed by the dealer at the time you purchase or lease your new vehicle.



Canada 

Accessories

YUKON AND YUKON XL MODEL SELECTOR	WHEELBASE mm (in.)	DRIVE	CARGO VOLUME L (cu. ft.) ¹	STD. GVWR ² kg (lb.)	MAX. PAYLOAD ⁴ kg (lb.)	MAX. GROSS TRAILER WEIGHT ⁵
1500 Yukon	2946 (116.0)	2WD	2962 (104.6)	2948 (6500) ³	692 (1525)	3493 (7700)
	2946 (116.0)	4x4	2962 (104.6)	3084 (6800) ³	729 (1608)	3538 (7800)
1500 Yukon Denali	2946 (116.0)	AWD	2962 (104.6)	3175 (7000)	661 (1457)	3674 (8100)
1500 Yukon XL	3302 (130.0)	2WD	3727 (131.6)	3175 (7000)	786 (1732)	3810 (8400)
	3302 (130.0)	4x4	3727 (131.6)	3266 (7200)	783 (1726)	3720 (8200)
1500 Yukon XL Denali	3302 (130.0)	AWD	3727 (131.6)	3266 (7200)	653 (1440)	3583 (7900)
2500 Yukon XL	3302 (130.0)	2WD	3727 (131.6)	3900 (8600)	1282 (2827)	5443 (12,000)
	3302 (130.0)	4x4	3727 (131.6)	3900 (8600)	1146 (2527)	5443 (12,000)

¹Maximum with rear seat(s) folded down or removed. ²Gross vehicle weight rating (GVWR) includes vehicle, passengers, equipment and cargo. ³When the third-row seat is specified, the GVWR is increased to 3084 kg (6800 lb.) for 2WD models, 3130 kg (6900 lb.) for 4x4s. ⁴Payloads are approximate and will change with the addition of optional or aftermarket equipment. Consult your dealer or equipment supplier for details. ⁵Trailer Weight (also called Trailer Towing Capacity) is the weight of a trailer, its load or contents plus any other weight added to the tow vehicle. Many trailer towing applications require optional equipment. Refer to the "Trailer with GMC Trucks" brochure for details.

SAFETY AND SECURITY

	SLE	SLT
Air bags – dual-stage, driver and right front-passenger, frontal. Includes Passenger Sensing System with automatic air bag suppression	S	S
Air bags – driver and front-passenger, seat-mounted side-impact	0	0
Brake/transmission shift interlock	S	S
Door locks – rear side door, child-security	S	S
Headlights – Daytime Running Lights with automatic light control	S	S
Keyless entry system – remote with Panic feature, includes rear cargo door, liftgate and liftglass	S	S
OnStar In-Vehicle Communications and Assistance Service – includes one-year Safe & Sound Plan	S	S
Safety restraints – LATCH (Lower Anchors and top Tethers for Children)	S	S
Theft-deterrent system – PASSLock	S	S
Theft-deterrent system – content theft alarm, audible/visible	S	S
Tire pressure monitor	S	S
Traction assist – electronic ⁶ (2WD)	0	0

MECHANICAL

	SLE	SLT
Brakes – Hydro-Boost power-assisted, 4-wheel disc with anti-lock braking system (ABS) and dynamic rear proportioning (DRP)	S	S
Engines – refer to page 19 for detailed availability	S	S
Exhaust system – aluminized stainless steel	S	S
Locking differential – rear (interim availability on certain models)	S	S
Quadrasteer – 4-wheel steering with mode selector switch on instrument panel, roof marker lights, unique rear flared fenders with clearance lights, limited-slip differential, Trailing Special Equipment Package and AutoRide Control suspension ⁷ (Yukon XL 2500 only)	0	0
StabiliTrak – vehicle stability enhancement system, including traction assist (except with Z71, Vortec 4800 V8 or Yukon XL 2500 models)	0	0
Snowplow Prep Package – (Yukon XL 2500 4x4)	0	0
Suspension – premium ride, includes rear self-levelling shock absorbers (Yukon 2WD and 4x4/Yukon XL 1500 2WD)	S	S
Suspension – premium ride, includes rear progressive rate coil springs (Yukon XL 1500 4x4)	S	S
Suspension – firm ride (Yukon XL 2500)	S	S
Suspension – AutoRide Control with real-time damping and air-assisted, self-levelling rear suspension ⁸ (standard on Denali)	0	0
Trailing Special Equipment Package – heavy-duty, includes weight-distributing platform with trailer hitch receiver, heavy-duty transmission oil cooler, high-capacity air cleaner and 7-pin sealed connector ⁹ (includes 7-pin to 4-pin adapter and trailer brake control harness)	0	0
Transfer case – Autotrac with electronic push-button controls (4x4 without StabiliTrak)	S	S
Transfer case – Borg-Warner 2-speed full-time all-wheel drive (AWD) open differential ¹⁰ (with optional StabiliTrak)	S	S
Transmission – 4-speed automatic with overdrive and Tow/Haul mode	S	S

EXTERIOR

	SLE	SLT
Assist steps – moulded, black	S	S
Doors – rear, liftgate with integral liftglass and rear-window wiper/washer	S	S
Fender flares – black, wheel opening (Yukon XL 2500)	S	S
Fog lights	S	S
Glass – Solar-Ray, tinted, deep-tinted behind front doors	S	S
Mirrors – manual foldaway, black, power remote control and heated	S	–
Mirrors – power foldaway, body-coloured, power remote control, reverse-tilt, heated, puddle lights with integral turn signals and driver's side electrochromic auto-dimming feature	0	S
Mirrors – camper-style, power remote control, heated, power extendable and integral turn signals ¹¹	0	0
Mouldings – bodyside, body-coloured with bright insert	S	S
Off-Road Package (Z71) – includes 17" X 7.5" 6-spoke aluminum wheels, P265/70R17 On-Off Road blackwall tires, 46 mm gas pressurized shock absorbers, Off-Road jounce bumpers, skid plates, high-capacity air cleaner and Z71 decals (Yukon 4x4 only)	0	0
Roof rack – side rails	S	S
Roof rack – cross bars	0 ¹²	S
Skid plates – protects front underbody, oil pan, differential case and transfer case (4x4 models only, standard in Z71)	0	0
Sunroof – power, sliding glass panel with express-open feature	0 ¹³	0
Tow hooks – two front (std. Yukon XL 2500 4x4 and Denali)	0	0
Tires – P265/70R16 all-season touring (1500 models)	S	–
Tires – P265/70R17 all-season ¹⁴ (1500 models)	–	S
Tires – LT245/75R16E all-season (Yukon XL 2500)	S	S
Wheels – 16" aluminum with steel spare, underbody ¹⁵	S	–
Wheels – 17" 6-spoke aluminum with 16" steel spare, underbody ¹⁵	–	S
Windshield wipers – 2-speed with variable delay, intermittent	S	S



INTERIOR	SLE	SLT
Air conditioning – tri-zone, manual climate control	S	–
Air conditioning – tri-zone, automatic climate control (std. in Denali)	0	S
Cargo Package – includes roof rack cross bars, cargo net, cargo mat and cargo shade ¹⁶ (std. in Denali)	0	S
Console – floor, includes storage, coin holders, cupholders, rear-seat audio controls (included with bucket seats)	0	S
Console – mini overhead, includes map lights, rear-seat HVAC controls	S	S
Cruise control – electronic with resume, coast and decelerate/accelerate features	S	S
Defogger – electric rear-window	S	S
Door locks – power, programmable with lock-out protection	S	S
Driver Information Centre – includes multi-language and trip functions, displays vital vehicle functions with both visual and audible reminders/warnings	S	S
Floor covering – colour-keyed carpeting with floor mats	S	S
Garage door opener – HomeLink 3-channel, universal transmitter (std. in Denali)	0	S
Heater – rear auxiliary	S	S
Instrumentation – full analogue gauge cluster (includes speedometer, tachometer, voltmeter, coolant temperature, oil pressure, fuel, odometer, trip odometer and engine hour meter)	S	S
Lights – overhead, reading and courtesy	S	S
Mirror – rear-view, includes compass, exterior temperature and front-passenger air bag status displays	S	S
Pedals – power adjustable brake and accelerator	0	S
Personalization feature – programs many comfort and convenience features (std. in Denali)	–	S
Power outlets – auxiliary 12-volt	S	S
Retained accessory power	S	S
Smoker's Package – includes lighter and ashtray (standard with front bench seat)	0	0
Steering column – tilt adjustable	S	S
Steering wheel – leather-wrapped	S	S
Steering wheel – controls for sound system and Driver Information Centre	S	S
Windows – power, driver's express-down and passenger window lock-out features	S	S

SEATS	SLE	SLT
Custom cloth 40/20/40 split-bench reclining front seat with power 6-way driver seat adjuster and folding centre armrest/storage	S	–
Custom cloth reclining high-back front bucket seats with inboard armrests, power 6-way driver seat-adjuster, rear seatback storage pockets, floor console, Bose premium speaker system with AudioPilot [®] noise-compensating technology and second-row audio controls	0	–
Full-feature reclining front bucket seats with leather seating surfaces , heated with separate controls for cushion and seatback, inboard armrests, power 10-way driver and front-passenger seat adjusters including power lumbar adjusters and seatback bolsters, 2-position driver's side memory controls and centre floor console	–	S
Second-row 3-passenger 60/40 split-folding bench with centre armrest	S	S
Second-row reclining bucket seats with inboard armrests	–	0
Third-row 3-passenger 50/50 flip-and-fold seat¹⁷ (Yukon)	0	0
Third-row 3-passenger full-folding bench seat¹⁷ (Yukon XL)	S	S

¹⁶Not available with StabiliTrak or Vortec 8100 V8. Required with QuadraSteer on 2WD models. ¹⁷Requires Vortec 6000 V8 and optional traction assist on 2WD models. ¹⁸Not available with 1500 models. ¹⁹Not available with 3.23 rear axle ratio. Trailering Special Equipment Package required when Sunroof and DVD Entertainment System are ordered together. ²⁰Vehicles produced after December 2004 will be equipped with an Autotrac (4x4) type transfer case and a locking differential. ²¹Requires available Trailering Special Equipment Package. ²²Roof rack cross bars available with cargo packages.

²³Not available with split-bench front seat. Includes HomeLink universal transmitter. ²⁴Available with White-outline letters. ²⁵Wheels shown on page 30.

²⁶Deletes cargo mat and cargo shade when optional 3rd-row seat is specified on Yukon and Yukon Denali. ²⁷3rd-row is vinyl when leather seating surfaces are specified. ²⁸Included with optional bucket seats. ²⁹Detailed map coverage is provided for most major urban areas of the United States and certain metropolitan areas of Canada (Quebec City, Montreal, Ottawa, Toronto, London, Windsor, Edmonton, Calgary and Vancouver). Outside these areas coverage is significantly limited. Please speak with your Sales Consultant regarding the Yukon navigation system's geographic coverage.

³⁰Available 20" chromed aluminum wheels on Denali and Denali XL (interim availability).

ENTERTAINMENT SYSTEMS	SLE	SLT
All Yukon/Yukon XL sound systems include an electronically tuned AM/FM stereo with seek/scan, Radio Data System (RDS), auto tone control and digital clock		
CD and cassette tape players	S	0
6-disc in-dash CD changer	0	S
Bose premium speaker system with AudioPilot[®] noise compensating technology	0 ¹⁸	S
Second-row audio controls – includes headphone jacks	0	S
DVD Entertainment System – includes overhead fold-down 178 mm (7 in.) LCD colour monitor, DVD player, video camera and video game input jacks, 2 sets of wireless headphones and remote control	–	0
Integrated DVD Navigation System – includes AM/FM stereo with CD player, Bose Premium 9-speaker sound system (including subwoofer) with AudioPilot [®] noise compensating technology, full-feature autonomous navigation with touch screen and points-of-interest ¹⁹	–	0

DENALI FEATURES

The Yukon Denali and Yukon XL Denali combine immense capability with extraordinary refinement to create a new standard for full-size SUVs. Listed below are some of the Yukon Denali and Yukon XL Denali features.

INTERIOR FEATURES

- Black Cherry simulated wood grain on centre console, instrument panel and front-door trim
- Driver and front-passenger seat-mounted side-impact air bags
- Heated full-feature high-back front bucket seats with 10-way power seat adjusters and 2-position driver's side memory controls
- Personalization feature
- Power adjustable pedals
- 2nd-row 60/40 split-folding bench seat with heated outboard positions
- 3rd-row full-folding bench seat (Yukon XL Denali); 3rd-row 50/50 split-folding bench seat (Yukon Denali)
- Driver Information Centre with multi-function trip computer
- AM/FM stereo with in-dash 6-disc CD changer, Bose Premium 9-speaker system with AudioPilot[®] noise compensating technology, power amplifier and second-row audio controls with headphone jacks

EXTERIOR FEATURES

- Body-colour front and rear bumpers
- Chrome grille
- Projector-beam style headlights
- 17" 6-spoke polished aluminum wheels²⁰
- Colour-keyed bodyside mouldings
- Colour-keyed running boards
- Two front tow hooks

MECHANICAL FEATURES

- Vortec 6000 V8 with 335 hp and 375 lb.-ft. of torque
- Full-time all-wheel-drive (AWD)¹⁹
- StabiliTrak vehicle stability enhancement system
- AutoRide Control suspension
- Trailering Special Equipment Package

DIMENSIONS, mm (in.)

Yukon

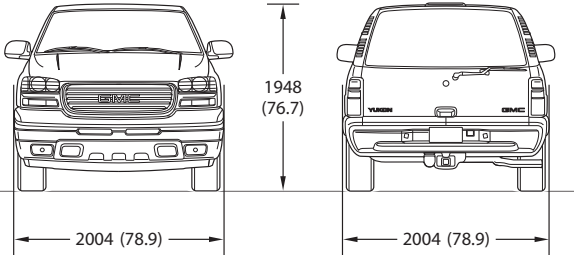
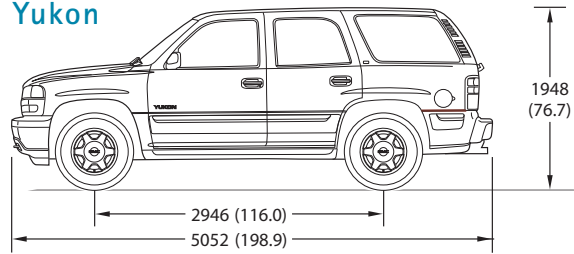

Yukon XL 1500

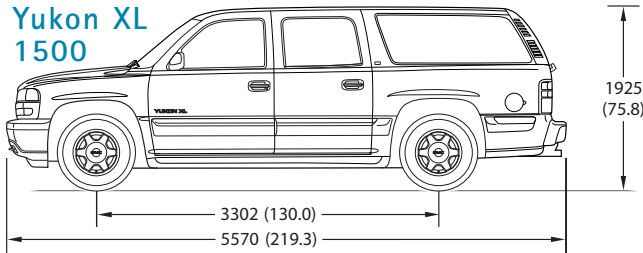

CARGO AREA DIMENSIONS, mm (in.)	YUKON	YUKON XL
Width of rear door opening	1247 (49.1)	1247 (49.1)
Height of rear door opening	916 (36.1)	916 (36.1)
Maximum cargo floor width	1250 (49.2)	1250 (49.2)
Cargo floor width between wheelhousings	1247 (49.1)	1247 (49.1)
Load floor length to front seat	2139 (84.2)	2657 (104.6)
Load floor length to second seat	1265 (49.8)	1768 (69.6)
Load floor length to rear seat	351 (13.8)	917 (36.1)
CARGO VOLUME, L (cu. ft.)		
With all seats in place	462 (16.3)	1294 (45.7)
With rear seat removed or folded	1801 (63.6)	2549 (90.0)
With 2nd-row folded and 3rd-row seat removed	2962 (104.6)	3727 (131.6)

WHEELS. FABRICS. CHOICES.

Yukon Wheels



16" x 7" (PF4)
Bright Aluminum.
Standard on Yukon and Yukon XL 1500 SLE and SLT.



17" x 7.5" (P27)
6-Spoke Aluminum.
Optional on Yukon and Yukon XL 1500 SLT. Included with Z71 Off-Road Package.



16" x 6.5" (PYO)
Polished Aluminum.
Standard on Yukon XL 2500 models.



17" x 7.5" (N93)
Polished Aluminum.
Standard on Yukon Denali and Yukon XL Denali.



20" x 8.5" (QS8)
Chromed aluminum.
Available on Yukon Denali and Yukon XL Denali.

Yukon/Yukon XL Interior Fabrics



Neutral
Custom cloth
Also available in Pewter



Neutral
Leather
Also available in Pewter

Yukon Denali/Yukon XL Denali Interior Fabrics



Sandstone
Leather



Stone Gray
Leather

A word about this brochure

Some of the equipment shown or described throughout this brochure may be available at extra cost. We have tried to make this brochure comprehensive and factual. We reserve the right, however, to make changes at any time, without notice, in prices, colours, materials, equipment, specifications, models and availability. Specifications, dimensions, measurements, ratings and other numbers in this brochure and other printed materials provided at the dealership or affixed to vehicles are approximates based upon design and engineering drawings and prototypes and laboratory tests. Your vehicle may differ due to variations in manufacture and equipment. Since some information may have been updated since the time of printing, please check with your GMC dealer for complete details. General Motors of Canada Limited reserves the right to lengthen or shorten the model year for any product for any reason, or to start and end model years at different times.

Privacy statement

At General Motors of Canada Limited ("GM Canada") we respect your privacy and value our relationship with you. Your personal information will be protected, will never be sold, and will be used only by GM Canada, our affiliates, dealers/retailers, and service suppliers (only to provide services). If you wish to be removed from GM Canada marketing communications; would like to limit only certain marketing communications from us; would like a listing of our specific uses or further information about those with whom your information is shared; or for further information about our Privacy Policy and practices, please contact us at 1-800-GM-DRIVE (1-800-463-7483) or through our Web site at www.gmcanada.com

A word about assembly

GMC Trucks are equipped with engines and components produced and assembled by different operating units of General Motors, its subsidiaries and suppliers and these engines and components may change or be obtained from different sources from time to time. All such engines and components are approved for use in GMC Trucks. Certain equipment ordered may be unavailable at the time of assembly and we suggest that you verify that your vehicle includes the equipment you ordered, or if there are changes, that they are acceptable to you.

Trademarks

The marks appearing in this Yukon brochure including, but not limited to: General Motors, GM, the GM Canada emblem, the GM Canada Web site address, the GM Accessories logo, GMC, the GMC logo, Canyon, Denali, Envoy, Envoy XUV, Jimmy, Safari, Savana, Sierra, Yukon and their respective logos, emblems, slogans and vehicle model names and body designs; and other marks such as Autotrac, ACDelco, AutoRide Control, DEX-Cool, PASSLock, SMARTLEASE, Solar-Ray, StabiliTrak, TOTAL Warranty and Vortec are all trademarks of General Motors Corporation and/or General Motors of Canada Limited, its subsidiaries, affiliates or licensors.

GMAC is a registered trademark of the General Motors Acceptance Corporation.

OnStar, the OnStar logo and the OnStar button are registered trademarks of the OnStar Corporation.

QuadraSteer and TheftLock are registered trademarks of Delphi Automotive Systems.

Bose and AudioPilot are registered trademarks of the Bose Corporation.

HomeLink is a registered trademark of the Prince Corporation.

Radio Data System (RDS) is a registered trademark of the U.S. National Association of Broadcasters.

Copyright

© Copyright 2004 General Motors of Canada Limited. All Rights Reserved. All text, images, graphics, and other materials in this Yukon brochure are subject to the copyright and other intellectual property rights of General Motors Corporation and/or General Motors of Canada Limited. These materials may not be reproduced, distributed or modified without the express written permission of General Motors Corporation and/or General Motors of Canada Limited.

COLOURS. BRILLIANT COLOURS.

Exterior Colours



15 Sand Beige Metallic



16 Steel Gray Metallic*



25 Deep Blue Metallic



26 Blue Green Crystal*



41 Onyx Black*



50



59



62 Carbon Metallic



63 Sport Red Metallic*

*Colours available on Denali models. Steel Gray Metallic available on Denali models only.



05 YUKON

At GMC, we set the highest possible standards for ourselves and our vehicles. Only the best is good enough – and only until we find a way to make it even better. This relentless pursuit of improvement has been going on for over a century now, and for 2005, it's resulted in the finest line of pickups, vans and SUVs we've ever built. If you believe, as we do, in only settling for the best, one of them could be for you.

THE GM COMMITMENT

Legendary engineering, quality and capability are only part of the GMC ownership experience. As a GMC owner, you also enjoy General Motors of Canada's commitment to your satisfaction. GM has created a wide range of programs to increase your enjoyment of your new vehicle. Some of these programs make it easier for you to obtain the GMC vehicle of your choice. Others enhance the ownership experience over the long term. Information on many of these programs is provided below.

THE GM TOTAL™ Warranty:†

The GM TOTAL™ Warranty is your promise of total warranty protection. It covers every new GMC Yukon or Yukon XL for 3 years or 60,000 km.* Complete vehicle repairs are covered,** including parts and labour, with no deductible. The warranty also includes:

- 3-year/60,000 km* complete vehicle repair coverage
- 5-year/160,000 km* corrosion perforation coverage
- 8-year/130,000 km* coverage on catalytic converters and powertrain control modules (PCMs).

*Whichever comes first. **To correct any defects in material or workmanship occurring during the warranty period. Regular maintenance is not included, nor is excessive wear and tear caused by reckless or negligent driving.

OTHER OWNERSHIP PRIVILEGES AND PROGRAMS:†

- Roadside Assistance – 24/7 service via toll-free number during your warranty period, anywhere in Canada or the United States
- Courtesy Transportation – may be offered during warranty period
- GM Protection Plan (GMPP) – the only extended service contract backed by the resources and commitment of General Motors; GMPP may be purchased at the time of your sale or lease, or subsequently
- GM Mobility Program – you may be eligible for reimbursement of up to \$1000 (taxes included) for adaptive equipment for your GM vehicle
- GM Accessories – personalize your vehicle with GM Accessories, specifically engineered for your new GM vehicle
- GM Goodwrench Service – with GM-certified technicians and GM-approved parts, nobody knows your GM vehicle better.

TO HELP YOU PURCHASE OR LEASE A GMC TRUCK:

- GMAC Financing – on-the-spot financing at your GM dealership††
- GMAC SMARTLEASE – a smart alternative to traditional financing††
- GM Graduate Program – recent graduates may qualify for up to \$1000 (taxes included) off any new GM vehicle†
- The GM Card – eligible cardholders may be able to redeem up to \$3500 in GM Card® Earnings toward the total purchase price or lease down payment on selected vehicles. For more information on The GM Card, please call 1-800-461-3279.†

INFORMATION RESOURCES:

You can find more information about these programs from your GM dealer, or at these information centres:

- The GM Web site at gmc.canada.com
- The GM Customer Communication Marketing Centre at 1-800-GM-DRIVE (1-800-463-7483 or 1-800-263-3830 for TDD users) – for information about any GM product or service, including The GM Card and the GM Mobility Program
- For information about GMAC visit the GM Web site or call 1-800-616-4622

†Conditions and limitations apply.

††Subject to eligibility.

CANYON

SIERRA

JIMMY

ENVOY

YUKON

SAFARI

SAVANA

05 YUKON

