

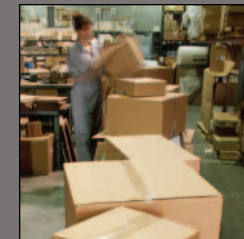

FE120

Go-to reliability.
Can-do attitude.





FE120: Sleek styling, solid reliability.

The new FE120 model combines dramatic styling, a newly re-engineered cab, chassis, components and go-where-you-point-it responsiveness with Mitsubishi Fuso's longstanding reputation for dependability. Its turbocharged 4-cylinder diesel is quieter and offers more torque. Its 5-speed manual transmission shifts even smoother. Available Aisin 6-speed automatic transmission offers enhanced drivability, especially on hills. A wider stance provides improved handling. Halogen headlamps offer superior visibility. Inside is a true driver's environment with more head, leg and elbow room, new instrumentation, tilt/telescoping steering wheel, adjustable seating, dash-mounted shifter and much, much more. Feature for feature, dollar for dollar, the new FE120 is the best vehicle in its class. And the right truck for the job.

FE120

- New, easier-to-read instrument panel
- Dash-mounted shifter provides more legroom
- Fold-down workstation, plus added storage area
- Tilt/telescoping steering wheel with one-touch quick release
- Forward swing doors open 70°, but feel like 90° wide



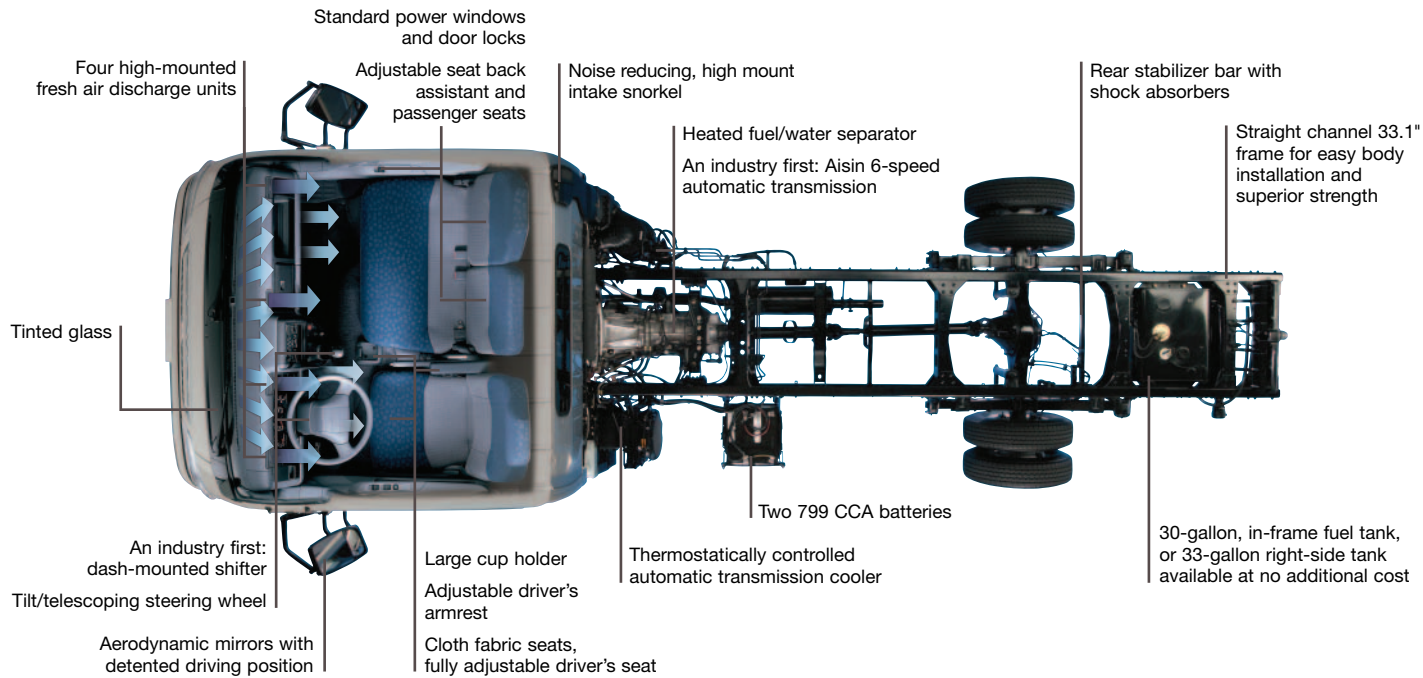

Safety

- Crush bar in each door
- Energy-absorbing steering wheel
- Daytime running lights
- Dual-caliper disc brakes with ABS, all wheels
- High-visibility halogen headlamps
- Covered, open-grate entry steps
- "Wet arm" 3-speed windshield wipers
- Forward swing doors for easy, safe entry

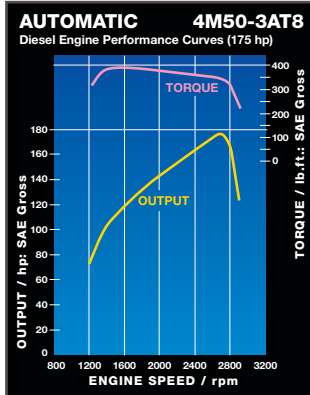
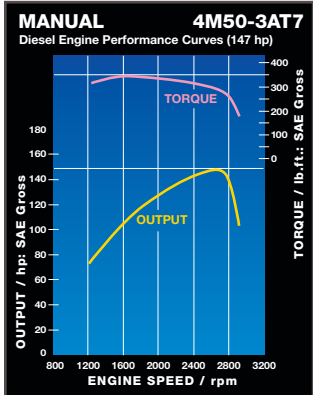

Engine

Model	Mitsubishi 4M50
Type	DOHC 4-stroke cycle, water-cooled, turbo-charged, intercooled diesel with 4 valves per cylinder and dual balance shafts
No. of cylinders	Four in-line
Piston displacement	299.0 cu.in. (4.9 liter)
Max. output (SAE, gross)	147 hp MT, 175 hp AT @ 2700 rpm
Max. torque (SAE, gross)	347 lb.-ft. MT, 391 lb.-ft. AT @ 1600 rpm
Air cleaner	Dry paper element with snorkel
Starter	12-volt
Alternator	12-volt, 100-amp
Cold weather starting aid	Individual ceramic-tipped glow-plugs

Body Colors

- Natural White 
- Arcadia Silver 
- Jupiter Green 
- Mars Red 
- Shannon Blue 

Fabric Style

- Blue and Gray Cloth 



FE120 Specifications

Chassis

Clutch	Organic
Clutch size	12.8"
Transmission	
Standard transmission	Mitsubishi 5-speed OD MT
Optional transmission	Aisin Electronic 6-speed OD AT
Estimated top speed (mph)	71 MT/75 AT
Axles	
Front	Reverse Elliot, I-beam type, 5,290-lb. capacity
Rear	Full floating type, 9,480-lb. capacity
Final reduction gear	Single-reduction hypoid gear
Ratio	4.875 MT/5.285 AT
Curb weight base model	5,633 lb.
Turning diameter (min. wheelbase)	35.1 ft.
Tires (premium)	Single front, dual rear
Size	215/85R16 10PR All-season all positions
Disc wheel	16"x6"/5-lug
Steering	Ball-nut-type with integral-type hydraulic power booster Tilt/telescoping steering column with steering lock
Windows/door locks	Power
Suspension	
Front	Laminated leaf springs with shock absorbers and stabilizer bar
Rear	Laminated leaf springs with shock absorbers and stabilizer bar
Brakes	
Service	Dual-caliper disc, hydraulic-type w/ vacuum servo assist w/ ABS
Parking	Drum/driveline, internal expanding shoe
Exhaust	Vacuum actuated
Frame	
Type	Ladder/straight
Section modulus	8.11 cu.in.
Yield strength	51,200 psi
RBM per rail	415,232 lb.-in.
Height/width	34.0"/33.1"
Fuel tank	33-gallon side mount, or 30-gallon aft axle
Electrical system	Two 12-volt, maintenance-free batteries – 799 CCA EA
Vehicle safety	Energy-absorbing steering wheel, crush bars in doors, daytime running lights and ABS standard

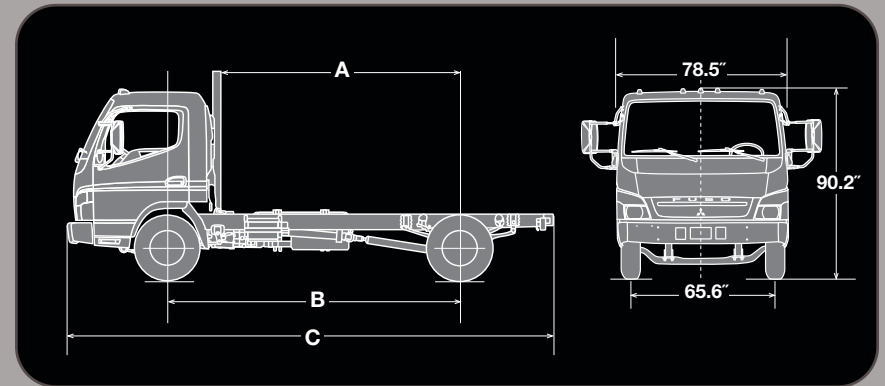

Dimensions

A. Usable cab to rear axle	87.5"	107.2"	125.3"
B. Wheelbase	114.6"	134.3"	152.4"
C. Overall length (end of frame)	228.2"	247.9"	266.0"
Body size accommodated	12'	14'	16'

Weight (lb.)*

GVWR (lb.)/GAWR (lb.)	12,000	Front 4,850	Rear 8,600
GCWR (lb.) MT/AT	17,012		
Max. body-payload capacity (lb.)	6,367		

*Weight approximate. See dealer for details.



MITSUBISHI FUSO TRUCK OF AMERICA, Inc.

2015 Center Square Road
Logan Twp., NJ 08085

For the dealer nearest you,
or for more information,
visit our web site at:

www.mitfuso.com

THE FE120 IS NOT AVAILABLE IN CERTAIN STATES. SEE DEALER FOR DETAILS.

Vehicle specifications are subject to change without notice. Photos and descriptions included on this spec sheet may vary in comparison to actual vehicle models.

♻️ PRINTED IN THE U.S.A. ON RECYCLED AND RECYCLABLE PAPER 6/04.
©2004 MITSUBISHI FUSO TRUCK OF AMERICA, Inc.