

Willys-Overland

MEETS TODAY'S NEEDS WITH THE DUAL-PURPOSE

'Jeep' Station Wagon

STEEL BODY • SEATS FOR 7 • 'JEEP' PERFORMANCE

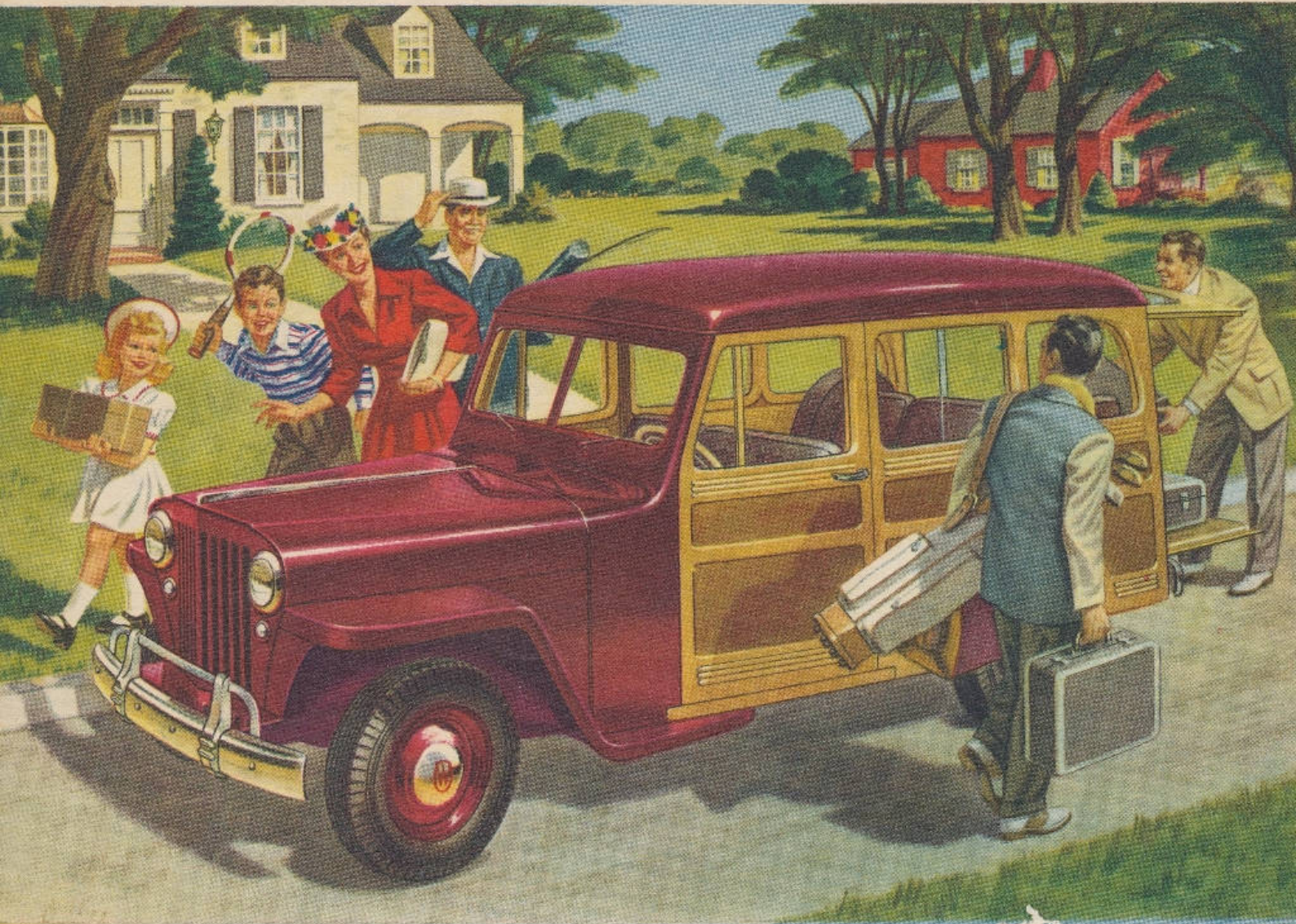

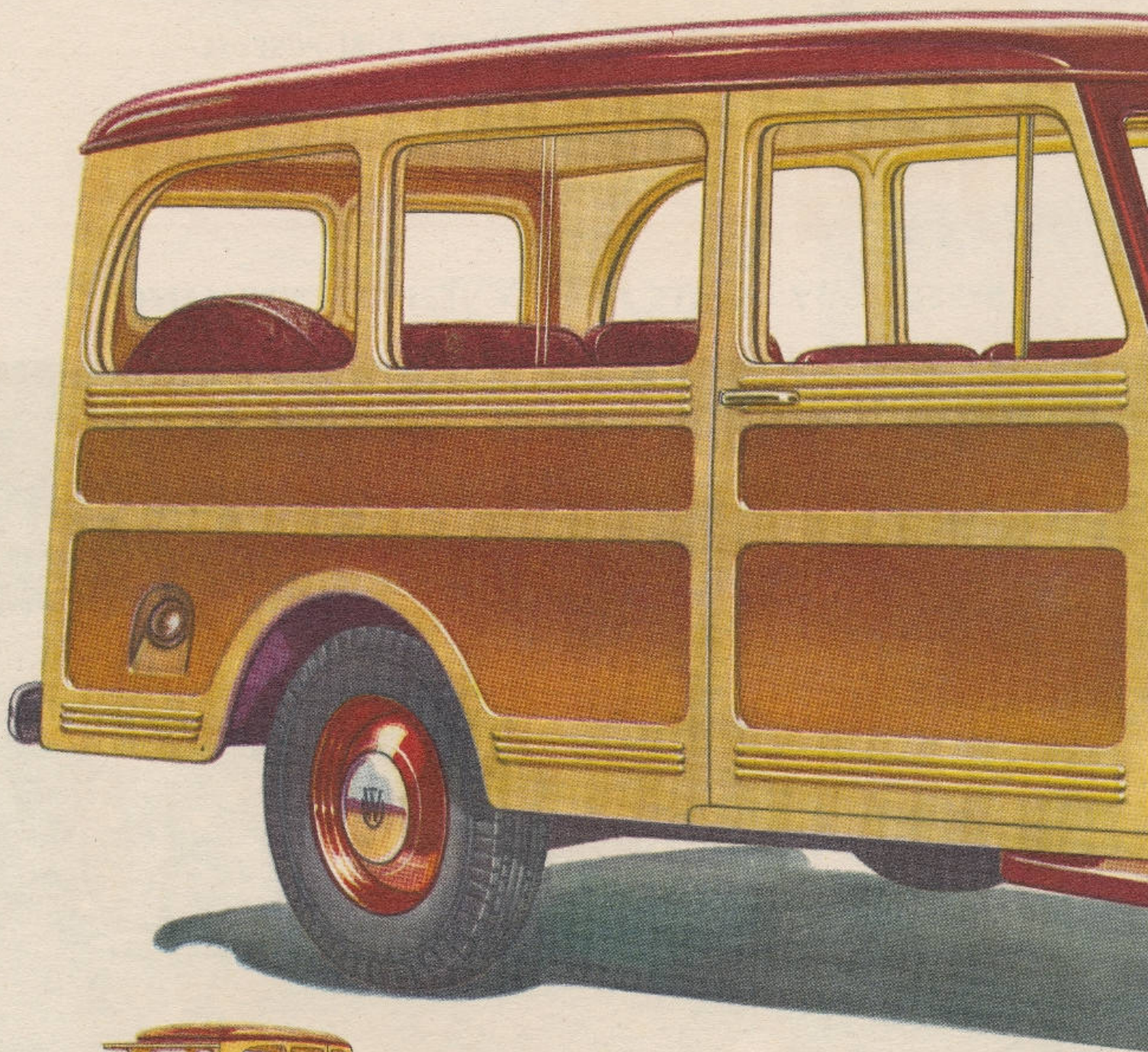

THE "JEEP" STATION WAGON... available in smart color combinations. Delivered with 5 wheels, 4 tires. Specifications and prices are subject to change.

The "Jeep" Station Wagon is the modern expression of Willys-Overland's years of experience in pioneering with automobiles that in utility, size, value and economy of operation truly meet the needs of the times. The functional design of the "Jeep" Station Wagon is a clean break with the traditional limitations of the conventional vehicle of this type . . . the full realization of the inherent possibilities of the station wagon. Its broad usefulness—with comfort for passengers and large load space—meets the pattern of today's living.

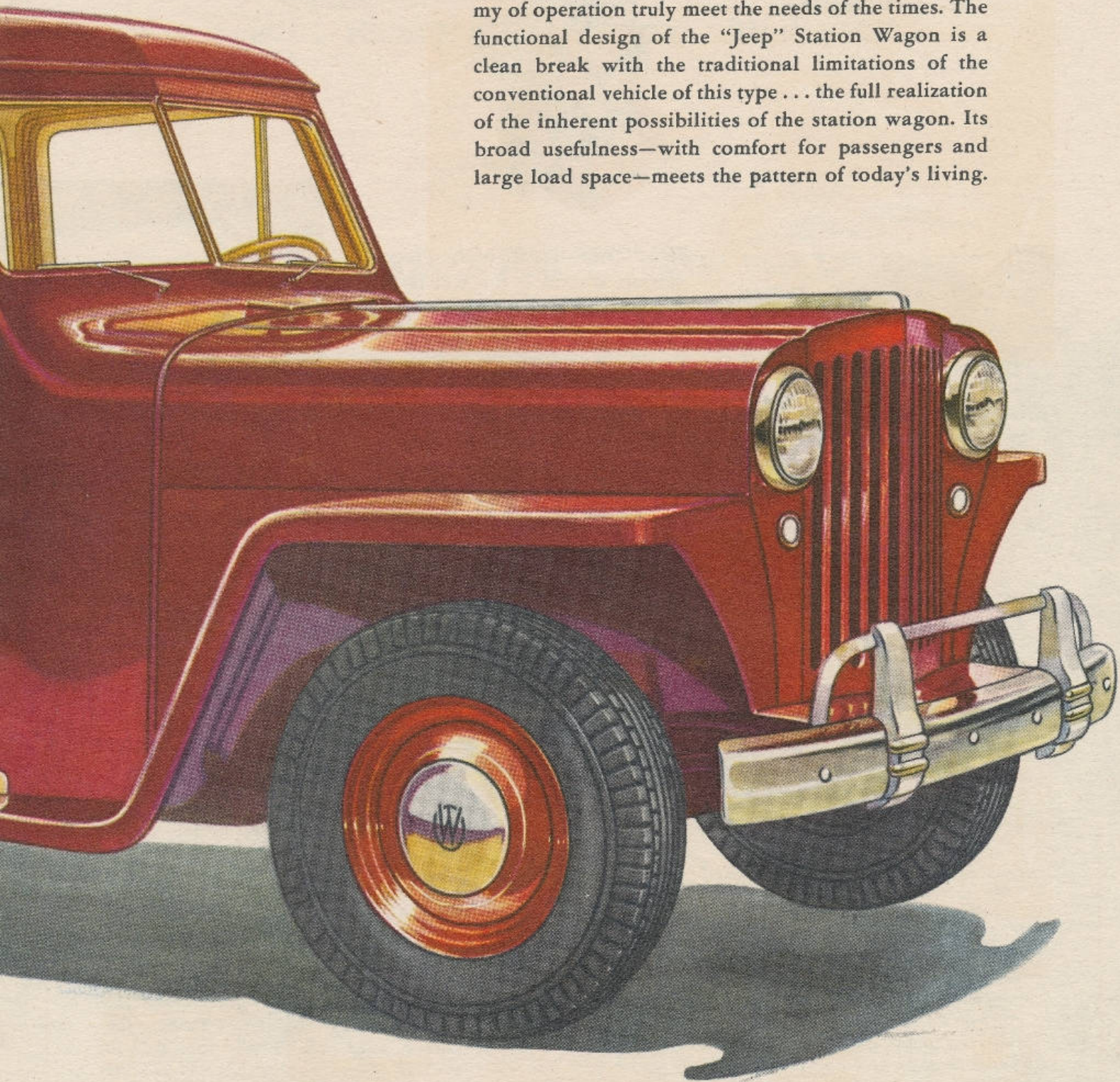

The 'Jeep' Station Wagon has all the features you demand

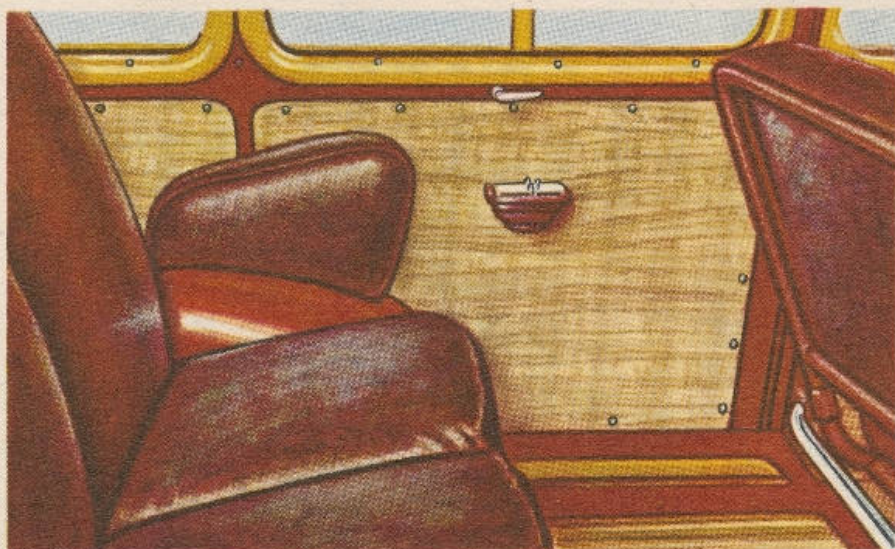

LUXURIOUS AND PRACTICAL INTERIOR, with body and door panels finished in aspen-grain finish, easy to keep clean. Arm-rests for driver and passenger upholstered to match simulated leather seat coverings.

INSTRUMENT PANEL is functionally designed for quick reading. Glove compartment at right. Space for radio at left of dash. Deluxe steering wheel with horn-button rim is standard equipment.

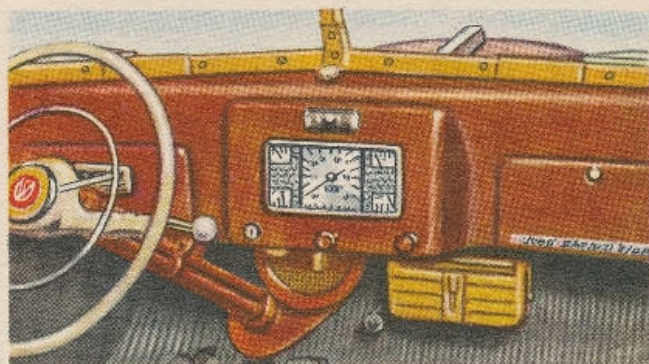

WIDE SAFETY-PLATE WINDSHIELD gives ample road visibility. Extra large windows give driver and passengers wide vision. Sun shades. Ceiling material is colorful, washable plastic-coated fabric. Rear vision mirror. Dome lights at front and rear.



DOOR LATCHES are finest trigger-and-button type. Exterior handle is closed at both ends—prevents torn pockets.

DOUBLE WINDSHIELD WIPERS on V-style windshield for clear vision in rain and snow.

TAIL LIGHT and license-plate holder swivels to position shown above at right when tailgate is left down to haul bulky objects.

Willys-Overland writes a New, Safer Chapter in Station Wagon History



Willys-Overland leads the way with a station wagon brought up to date, engineered to fit the realities of practical use. The "Jeep" Station Wagon has an ALL-STEEL body and one-piece steel top for maximum safety and long service. The finish lasts. No wood-body squeaks and rattles, peeling and weathering. No re-painting next year. The steel body means less weight, longer mileage. And there is safety-plate glass all around.

and builds in Luxurious Comfort, Convenience and Utility



Easy-riding seats built with new-type springs, hair felt and cotton padding. Upholstered in durable simulated leather. Modern tubular-steel frames with chrome foot rests. All except driver's seat can be removed.



Meeting the problem of over-crowded streets, Willys-Overland designed the "Jeep" Station Wagon for nimble handling in traffic . . . easy parking in small spaces.

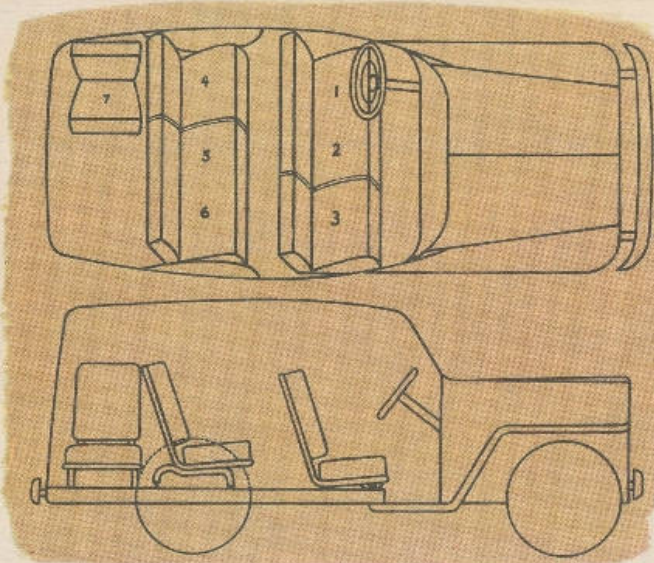

Diagrams show 7 full-size seats for adults, with plenty of head, shoulder and leg room. Below, with all except driver's seat removed, you have big carrying space—56 usable cubic feet.

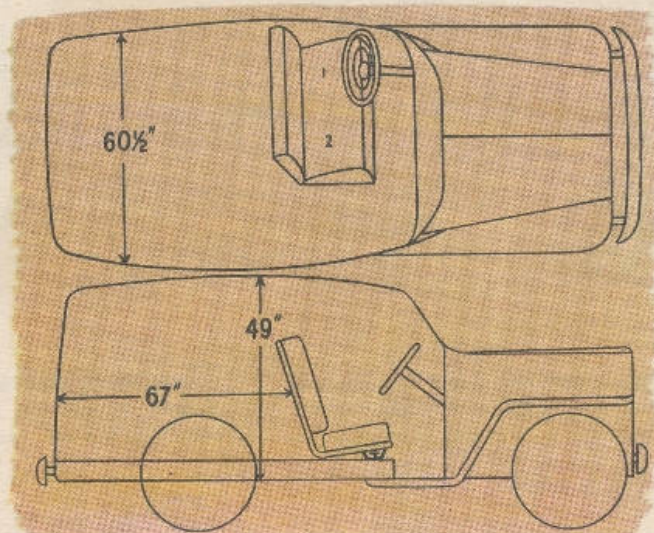

Powered by the World-Famous Willys-Overland 'Jeep' Engine

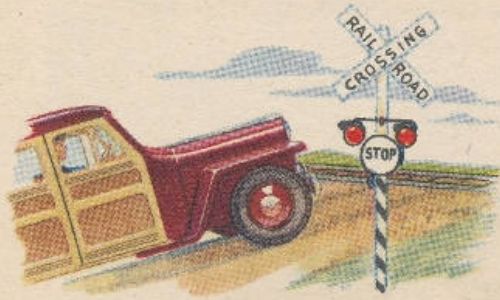

4-WHEEL HYDRAULIC BRAKES of the "Jeep" Station Wagon, with extra large braking surface, give you ample safety and driving control.

THE POWER-HEART of the "Jeep" Station Wagon is the war-tested Willys-Overland "Jeep" Engine, used in 500,000 fighting Jeeps—world-famous for stamina, performance and economy. This mighty engine has been further improved in many ways and refined for even more brilliant performance and longer gasoline and oil mileage.



SEALED-BEAM HEADLIGHTS with toe-tip control and parking lights are well protected from collision damage.

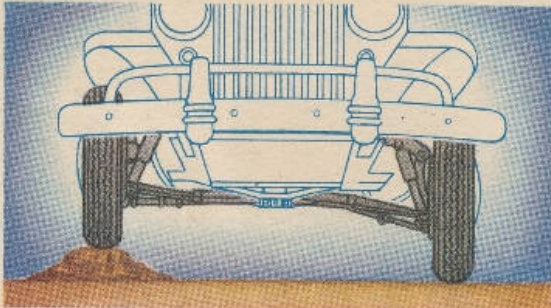

STABILIZED RIDING and easier steering result from Willys-Overland's new front-wheel suspension and rubber-insert springs. Diagram at left shows how one wheel goes over a road obstruction, maintaining a nearly vertical plane and with minimum body tilt. The result is an easier ride, more tire economy and better steering control.

Willys-Overland "Overdrive" Gives You Extra Operating Economy and Longer Engine Life

Economy of operation is a feature of the "Jeep" Station Wagon. For *extra* economy in highway driving, it is equipped with selective overdrive.

At speeds over 30, you go into overdrive by merely lifting your foot momentarily from the accelerator . . . the engine slows down 30 per cent . . . but you skim along with no reduction in road speed!

When you wish to return to conventional drive,

just press the accelerator to the floor for an instant.

For example, when you are driving at 60, you let up the accelerator and go into overdrive. The car keeps on doing 60, but the engine now turns at the rate it does when you travel 42 miles per hour in conventional drive. With the overdrive, you use less gasoline and oil . . . lengthen engine life.

It's modern . . . it's thrilling . . . it's thrifty.

The Overdrive is included in the "Jeep" Station Wagon at No Extra Cost

WILLYS-OVERLAND EXPORT CORP., TOLEDO 1, OHIO, U. S. A. Cable Address WILLYSEXCO