

# INTERNATIONAL®



# 1100 A

## RATINGS

### MAXIMUM GROSS VEHICLE WEIGHTS:

Standard.....	4,700 lbs.
With Heavy-duty Rear Springs.....	5,800 lbs.

## STANDARD EQUIPMENT

### AXLE, FRONT

FA-1, 2500-lb capacity  
Heat-treated forged-steel I beam

### AXLE, REAR

RA-5 3,500-lb capacity  
Hypoid single reduction, 9 $\frac{3}{4}$ " ring gear  
Semi-floating, induction hardened shafts  
Ratios: 3.73, 4.10, 4.78 or 5.13 to 1

### BRAKES, PARKING

Mechanical control of rear service brakes  
Foot pedal applied, finger lever released  
Total lining area: 79.3 sq. inches

### BRAKES, SERVICE

Self adjusting hydraulic  
Single-cylinder, single-piston front  
Single-cylinder, double-piston rear  
Size: 12 x 1 $\frac{3}{4}$ " front, 12 x 1 $\frac{3}{4}$ " rear  
Total lining area: 161.2 sq. inches

### CAB

All steel, with safety glass windows and sweep-around windshield  
Door locks both sides with safety latches  
Non-glare instrument panel with ammeter, fuel, water temperature and oil pressure gauges  
Full-width adjustable seat, with Torflex spring construction, vinyl upholstery and polyurethane foam cushion

### CAB (Continued)

Acoustical roof headliner  
Rubber floor mat, with sound deadening insulation  
Sun visor for driver; inside rear view mirror  
Ash tray; hand choke  
Two-speed electric windshield wipers  
Chrome door-mounted mirror

### CLUTCH

10-inch 9-spring single-plate  
Hydraulic control; vibration dampener

### COOLING SYSTEM

18.5 quart system capacity  
Radiator frontal area: 497 sq. inches

### ELECTRICAL SYSTEM

12-volt 37-amp alternator  
50 amp-hr, 54-plate battery  
Fuse panel in glove compartment  
Dual stop and tail lights  
Dome light; single electric horn  
Directional signals: front in parking lights, rear in stop lights

### ENGINE

International BG-241 gasoline six  
Gross BHP: 140.8 @ 3800 rpm  
Gross torque: 223.5-lb ft @ 2000 rpm  
241 cu. in. displmt., 7.5 to 1 compr. ratio  
Oil bath air cleaner; full-flow oil filter

### FINISH

Chassis: black; bumper: white  
Hood, cab, fenders and wheels:  
choice of any standard IH color

### FRAME

Pressed steel channel main rails  
115"-131" WB: 6 $\frac{15}{16}$  x 2 $\frac{31}{32}$  x 0.150";  
3.98 sec. mod.  
140" WB: 7 x 3 x 0.179"; 4.81 sec. mod.  
Formed-channel front bumper

### FUEL TANK

19-gallon, mounted under cab

### STEERING

S-3 gear, with 17-inch steering wheel

### SUSPENSION

Semi-elliptic steel leaf springs  
Front: 2 $\frac{1}{2}$  x 46"; 2,340-lb capacity  
Rear: 2 $\frac{1}{2}$  x 52"; 2,760-lb capacity  
Front and rear shock absorbers

### TRANSMISSION

T-4 three-speed synchromesh, direct  
Gear shift lever on steering column  
Ratios: 3.03, 1.64, 1.00; 3.68 rev.

### WHEELS AND TIRES

Single front and rear, with spare  
8.15 x 15 4-PR tubless tires  
5-stud disc wheels, with 5.50K rims  
Painted hub caps, front and rear

## OPTIONAL EQUIPMENT

### AXLE, FRONT

FA-10, 3,200-lb capacity, with  
3,260-lb capacity springs

### AXLE, REAR

RA-6 3,500-lb capacity single reduction,  
with Powr-Lok limited-slip differential  
Ratios: 3.73, 4.10, 4.78, 5.13

### BODIES

7-ft. or 8 $\frac{1}{4}$ -ft regular pickup body,  
with underslung tire carrier  
7-ft, 8-ft or 8 $\frac{1}{4}$ -ft Bonus-Load pickup body,  
with inside body tire carrier  
Travelall® body, with four side doors,  
rear tailgate with electrically operated  
roll-down window, white rear bumper,  
inside body tire carrier  
Optional: Full width fold-down  
center seat, removable rear seat,  
panel-type rear doors,  
trim packages

### BODIES (Continued)

Panel body with four side doors,  
double rear doors,  
driver's individual bucket seat,  
dual stop and tail lights, white rear  
bumper  
8-ft stake or platform body  
6-ft Bonus-Load pickup body,  
with inside body tire carrier  
(for Travelette cab)

### BRAKES, SERVICE

Vacuum power assist system

### CAB

Deluxe interior trim package  
Custom interior trim package  
Exterior trim package

### SAFETY PACKAGE:

(Mandatory Option)  
Seat belts  
Padded sun visors  
Padded dash

### CAB (Continued)

### SAFETY PACKAGE (Continued)

Windshield washer  
Hazard switch  
Camper package  
4-door, 6-passenger Travelette cab  
Full-width or passenger seat  
(for panel body)  
Flat back cowl or front end section,  
in lieu of cab  
Tinted glass  
Arm rest, left or right side  
Glove box lock  
Chrome door-mounted passenger side  
mirror  
Right outside mirror  
Fresh air or recirculating heater  
Super-capacity heater-defroster

### CLUTCH

11-inch 9-spring  
11-inch 12-spring  
12-inch 12-spring

*Illustration May Include Optional Equipment*



**COOLING SYSTEM**

Increased capacity system  
Permanent anti-freeze: -20°F

**ELECTRICAL SYSTEM**

52-amp alternator  
60 or 70 amp-hr battery; cigar lighter  
Dual electric horns; radio  
Three front marker lights  
Two front corner lamps  
Camper electrical connector  
Backup lights\*  
\*Standard with Travelall

**ENGINE**

V-266 154.8-BHP gasoline V8  
V-304 193.1-BHP gasoline V8  
V-304 LPG 180-BHP LPG V8  
BG-241 LPG 131.8-BHP LPG 6-cylinder  
BG-265 153.5-BHP gasoline six  
Heavy-duty oil bath air cleaner  
High altitude equipment

**OPTIONAL EQUIPMENT**

**ENGINE (Continued)**

Magnetic fan drive  
Hand throttle control; carburetor heater  
Velocity-type engine governors  
Exhaust emission control  
Automatic choke

**FRAME**

Underslung tire carrier, for Bonus-Load pickup body, chassis and cab, Travelall and Panel  
Left side mounted outside tire carrier, with regular pickup body  
Spare tire lock  
Chrome front and rear bumper  
White rear bumper

**FUEL TANK**

Auxiliary 14-gallon tank under left side of Travelall body, with dash-mounted tank selector

**STEERING**

Hydraulic power assist system

**(Continued)**

**SUSPENSION**

2,520-lb capacity HD front springs, for FA-1  
2,620-lb capacity progressive rear springs  
3,310-lb capacity HD progressive rear springs  
5,520-lb capacity main and auxiliary rear springs

**TRANSMISSION**

T-7 heavy-duty 3-speed, with floor-mounted control lever  
T-15 heavy-duty 4-speed, with floor-mounted control lever  
T-8 four-speed overdrive  
T-28 three-speed automatic  
T-34 HD 5-speed, overdrive  
T-36 HD 5-speed direct  
Oil cooler for T-28

**WHEELS AND TIRES**

Optional tire sizes as shown below  
Chrome hub caps, front and rear

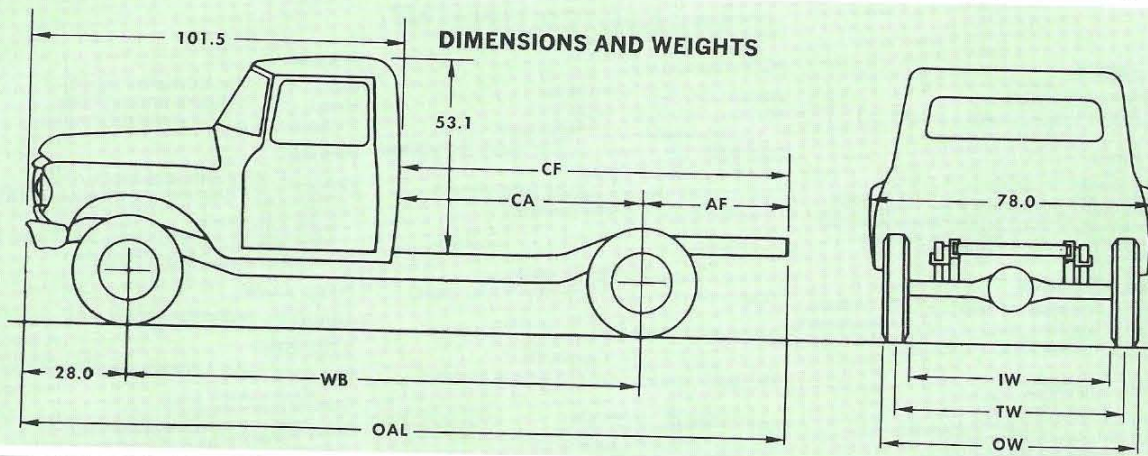

**DIMENSIONS, with 8.15 x 15 TIRES**

Overall Width: 78" at front fenders	Ground Clearance: 7.4" at front axle	Frame Height at Rear Axle: 26.8" empty
Overall Height: 69.8" at top of cab	7.6" at rear axle	23.4" loaded

**CHASSIS DIMENSIONS and WEIGHTS**

WB	CHASSIS WEIGHTS, LBS.*			DIMENSIONS				TURNING RADIUS	
	Front	Rear	Total	CA	CF	AF	OAL	To Centerline of Tire	With Bumper Clearance
115"	2,160	1,020	3,180	42"	85.5"	43.5"	187"	19 ft. 6 in.	20 ft. 9 in.
119"	2,160	1,020	3,180	45.5"	85.5"	40"	187"	20 ft. 0 in.	21 ft. 6 in.
122"	2,160	1,025	3,185	49"	85.5"	36.5"	187"	20 ft. 6 in.	21 ft. 9 in.
131"	2,175	1,030	3,205	57.5"	103.5"	46"	205"	21 ft. 9 in.	23 ft. 3 in.
140**	2,350	1,275	3,625	31.5"	71.5"	40"	208.5"	23 ft. 0 in.	24 ft. 6 in.

\*Chassis and cab with standard equipment, oil, fuel and water.

\*\*With Travellette Cab.

**TIRE DIMENSIONS**

Tire Size	TUBELESS TIRES ON DISC WHEELS				TIRES AND TUBES ON DISC WHEELS	
	8.15x15	8.45x15	7.00x15	6.50x16	7.00x15	7.00x15
Rim Size	5.50K	6.00L	6.00L	5.00K	5.50F	6.00L
Outside Width OW	69.2"	68.8"	69.3"	67.8"	68.3"	69.3"
Tread Width TW	61.3"	61.6"	61.6"	60.6"	60.6"	61.6"
Inside Width IW	53.4"	53.3"	59.9"	53.5"	52.9"	59.9"
Chain Clearance	5.6"	5.6"	5.9"	5.6"	5.3"	5.9"
Front Tread	61.2"	61.4"	61.4"	60.5"	60.5"	61.4"

In order that product improvements may be introduced at any time, specifications are subject to change without notice.

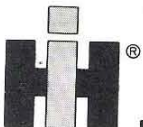

**INTERNATIONAL HARVESTER COMPANY • 401 NORTH MICHIGAN AVE. • CHICAGO, ILLINOIS 60611**

CT-400-D. AD-4236-S3. 2-1-S.

ORDER AD SPEC. SHEETS ON AD-4130.

Litho in United States of America