



RATINGS

MAXIMUM GROSS VEHICLE WEIGHTS:

Standard	7,000 lbs.
With FA-18 Front Axle	7,400 lbs.

STANDARD EQUIPMENT

AXLE, FRONT

FA-15 2,800-lb capacity driving
Hypoid single reduction, 8 $\frac{1}{2}$ " ring gear
Ratios: 4.09 or 4.89 to 1

AXLE, REAR

RA-16 5,500-lb capacity
Hypoid single reduction, 9 $\frac{3}{4}$ " ring gear
Full-floating, induction-hardened shafts
Ratios: 4.10, 4.88 to 1

BRAKE, PARKING

Mechanical control of rear service brakes
Foot pedal applied, finger lever released
Totaling lining area: 90.6 sq. inches

BRAKES, SERVICE**Hydraulic**

Single-cylinder single-piston front,
Single-cylinder double-piston rear
Size: 12 x 1 $\frac{3}{4}$ " front, 12 x 2" rear
Total lining area: 174.0 sq. inches

CAB

All steel, with safety glass windows and
sweep-around windshield
Door locks both sides with safety latches
Non-glare instrument panel with ammeter,
fuel, water temperature and
oil pressure gauges
Full-width adjustable seat, with Torflex
spring construction, vinyl upholstery and
polyurethane foam cushion
Acoustical roof headliner
Rubber floor mat, with
sound deadening insulation

CAB (Continued)

Sun visor for driver; inside rear view mirror
Ash tray; hand choke
Two-speed electric windshield wipers
Seat belt anchors

CLUTCH

10-inch 9-spring single-plate
Hydraulic control; vibration dampener

COOLING SYSTEM

18.5 quart system capacity
Radiator frontal area: 497 sq. inches

ELECTRICAL SYSTEM

12-volt 37-amp alternator
50 amp-hr, 54-plate battery
Fuse panel in glove compartment
Dual stop and tail lights
Dome light; single electric horn
Directional signals: front in parking lights,
rear in stop lights

ENGINE

International BG-241 gasoline six
Gross BHP: 140.8 @ 3800 rpm
Gross torque: 223.5 lb-ft @ 2000 rpm
241 cu. in. displmt.; 7.5 to 1 compr. ratio
Oil bath air cleaner; full-flow oil filter

FINISH

Chassis: black; bumper: white
Hood, cab, fenders and wheels:
choice of any standard IH color

FRAME

Pressed steel channel main rails
7 x 3 x 0.179"; 4.80 section modulus
Formed channel front bumper

FUEL TANK

19-gallon, mounted under cab

STEERING

S-3 gear, with 17-inch steering wheel

SUSPENSION

Semi-elliptic steel leaf springs
Front: 2 $\frac{1}{2}$ x 42"; 3,660-lb capacity
Rear: 2 $\frac{1}{2}$ x 52"; 6,000-lb capacity
Front and rear shock absorbers

TRANSFER CASE

TC-141 two-speed constant mesh
Single control lever selects high or
low range and front axle declutch;
permits low range operation in
four wheel drive only
Ratios: 1.96 and 1.00 to 1
Provision for full torque PTO

TRANSMISSION

T-4 three-speed synchromesh, direct
Gear shift lever on steering column
Ratios: 3.03, 1.64, 1.00; 3.68 rev.

WHEELS AND TIRES

Single front and rear with spare rim
7-17.5 6-PR truck type tires
6-stud disc wheels, with 5.25DC rims

OPTIONAL EQUIPMENT

AXLE, FRONT

FA-18 3,500-lb capacity, driving with
4,480-lb springs
Ratios: 4.10 or 4.89 to 1
Warn locking hubs. Tie rod guards

AXLE, REAR

RA-17 5,500-lb capacity single reduction
with Powr-Lok limited slip differential
Ratios: 4.10 or 4.88 to 1

BODIES

7-ft or 8 $\frac{1}{4}$ -ft regular pickup body, with
underslung or optional inside body
tire carrier
7-ft, 8-ft or 8 $\frac{1}{4}$ -ft Bonus-Load pickup body,
with inside body carrier
Travelall body, with four side doors,
rear tailgate with electrically operated
roll-down window, white rear bumper,

BODIES (Continued)

inside body tire carrier, front seat belts
and padded dash
Optional: Full width fold-down
center seat, removable rear seat,
panel-type rear doors,
trim packages

Panel body with four side doors,
double rear doors,
driver's individual bucket seat,
dual stop and tail light, white rear bumper

8-ft stake or platform body
6-ft Bonus-Load pickup body, with
inside body tire carrier
(for Travelette cab)

9-ft stake or platform body

BRAKES, SERVICE

Vacuum power assist system

BRAKES, SERVICE (Continued)

Vacuum line air cleaner
Vacuum reserve tank with gauge and
warning light

CAB

Deluxe interior trim package
Custom interior trim package
Exterior trim package
Safety package
4-door, 6-passenger Travelette cab
Full-width or passenger seat
(for panel body)
Flat back cowl or front end section,
in lieu of cab
Right side sun visor; tinted glass
Arm rest, left or right side
Glove box lock
Chrome cowl mirrors, single* or dual
*Standard on Travelall

Illustration May Include Optional Equipment

OPTIONAL EQUIPMENT (Continued)

CAB (Continued)

Fixed outside mirrors, single or dual
Fresh air or recirculating heater
Super-capacity heater-defroster
Electric windshield washers*
Sliding rear cab window

CLUTCH

11-inch 9-spring
11 inch 12-spring
12-inch 12-spring

COOLING SYSTEM

Increased capacity cooling
Permanent anti-freeze: -10°F or -40°F

ELECTRICAL SYSTEM

52-amp alternator
60 or 70 amp-hr battery
Dual electrical horns; cigar lighter
Traffic hazard switch*
Three front marker lights
Two front corner lamps
Backup lights*

*Standard on Travelall

ELECTRICAL SYSTEM (Continued)

Camper electrical connector
Front axle warning light
Radio and antenna

ENGINE

BG-265 153.5-BHP gasoline six
V-266 154.8-BHP gasoline V8
V-304 193.1-BHP gasoline V8
Automatic choke
Heavy-duty oil bath air cleaner
High altitude equipment
Magnetic fan drive
Velocity-type engine governor
Hand throttle control; carburetor heater
Exhaust emission control

FRAME

Underslung tire carrier; carrier lock
Left outside tire carrier for regular pickup
Two front tow hooks
Chrome front and rear bumper
White rear bumper

FUEL TANKS

Auxiliary 14-gallon under Travelall body
with dash-mounted selector
15-gallon under cab, in lieu of standard

STEERING

Hydraulic power assist system

SUSPENSION

6,590-lb capacity main and
auxiliary rear springs

TRANSMISSION

T-7 HD 3-speed direct synchromesh with
floor-mounted control lever
T-16 HD four-speed with floor-mounted
control lever
T-34 HD 5-speed, overdrive
T-36 HD 5-speed, direct
Front-mounted winch, cable and hook
Full torque PTO for transfer case
Transmission-mounted PTO

WHEELS AND TIRES

Optional tire sizes as shown below
Chrome hub caps, front and rear

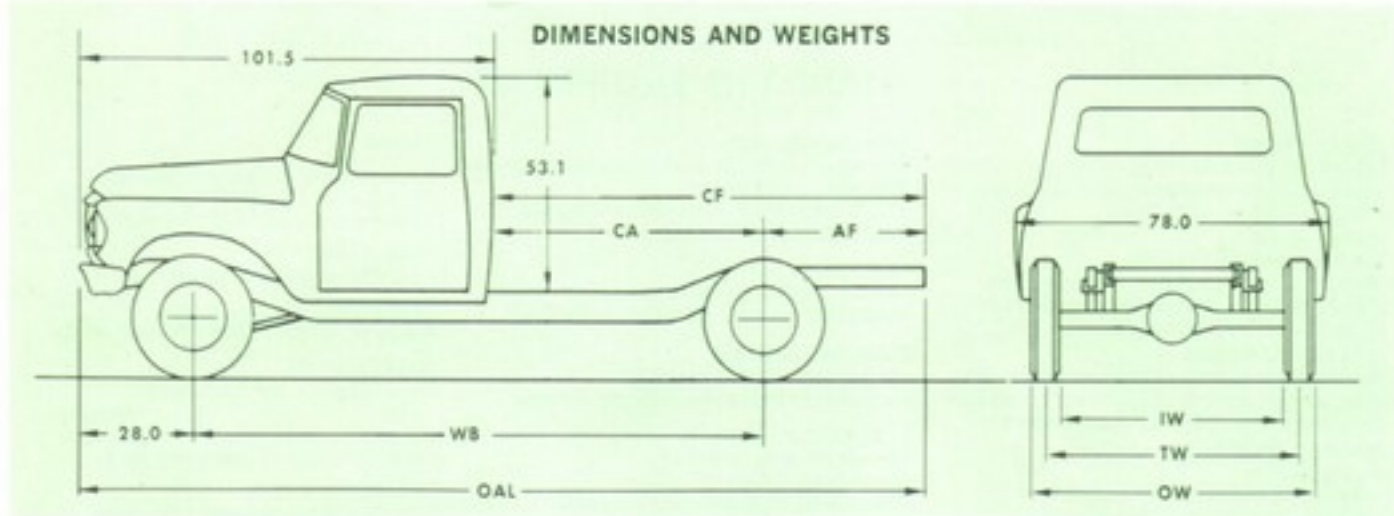

DIMENSIONS with 7 x 17.5 TIRES

Overall width: 78" at front fenders	Ground Clearance: 9.2 at front axle	Frame Height at Rear Axle: 30.8 empty
Overall height: 74" at top of cab	8.3 at rear axle	27.7 loaded

CHASSIS DIMENSIONS and WEIGHTS

WB	WEIGHTS*			DIMENSIONS				TURNING RADIUS	
	Front	Rear	Total	CA	CF	AF	OAL	To Centerline of Ties	With Bumper Clearance
115"	2,570	1,250	3,820	42"	85.5"	43.5"	187"	23 ft. 0 in.	24 ft. 6 in.
119"	2,570	1,255	3,825	45.5"	85.5"	39.5"	187"	23 ft. 9 in.	25 ft. 3 in.
122"	2,570	1,255	3,825	49"	85.5"	36.5"	187"	24 ft. 3 in.	25 ft. 9 in.
131"	2,585	1,260	3,845	57.5"	103.5"	46"	205"	26 ft. 0 in.	27 ft. 3 in.
134"	2,600	1,265	3,865	61"	103.5"	42.5"	205"	26 ft. 6 in.	28 ft. 0 in.
140***	2,805	1,465	4,270	31.5"	71.5"	40"	208.5"	27 ft. 6 in.	29 ft. 0 in.

*With regular cab, standard equipment, oil, fuel, and water. **With Travelite Cab, standard equipment, oil, fuel, and water.

TIRE DIMENSIONS

Tire Size	TUBELESS ON DISC WHEELS			TIRES AND TUBES ON DISC WHEELS					
	7x17.5	8x17.5	8x19.5	6.50x16	7.00x16	7.50x16	9.00x16	7.00x18	7.50x18
Rim Size	5.25	5.25	5.25	4.50E	5.50F	5.50F	6.50H	5.50S	5.50S
Outside width	70.3"	70.7"	70.7"	69.9"	70.7"	71.2"	72.4"	70.5"	71.4"
Tread Width	63.0"	63.0"	63.0"	63.0"	63.0"	63.0"	63.0"	63.0"	63.0"
Inside Width	55.7"	55.3"	55.3"	56.1"	55.4"	54.8"	53.6"	55.5"	54.6"
Chain clearance	7.99"	7.79"	7.79"	6.94"	6.55"	6.29"	5.67"	6.63"	6.17"
Front Tread	63.5"	63.5"	63.5"	63.5"	63.5"	63.5"	63.5"	63.5"	63.5"

In order that product improvements may be introduced at any time, specifications are subject to change without notice.



INTERNATIONAL HARVESTER COMPANY • 401 NORTH MICHIGAN AVE. • CHICAGO, ILLINOIS 60611

CT-400-D. AD-4239-S3. 2-1-S.

ORDER AD SPEC. SHEETS ON AD-4130.

Litho in United States of America