

# INTERNATIONAL®



# 908 C

Vehicle illustrated may include Optional Equipment and does not necessarily include all standard equipment.

## RATINGS

**MAXIMUM GROSS VEHICLE WEIGHT**.....4,000 lbs.

## STANDARD EQUIPMENT

### AXLE, FRONT

FA-1 2,500-lb capacity  
Heat-treated forged-steel I beam

### AXLE, REAR

RA-18 3,500-lb capacity  
Hypoid single reduction, 8½" ring gear  
Semi-floating induction-hardened flanged shafts

Ratios: 3.31, 3.54 or 3.73

### BODY

6 ft. 8 in. regular or Bonus-Load pick-up  
with inner body tire carrier

### BRAKE, PARKING

Mechanical control of rear service brakes  
Foot pedal applied, finger lever released  
Total lining area: 81.9 sq. inches

### BRAKES, SERVICE

Self-adjusting hydraulic, dual operation  
with warning light

Single-cylinder, single-piston front,  
single-cylinder, double-piston rear

Size: 12 × 2" front, 11 × 1¾" rear  
Total area: 179.7 sq. inches

### CAB

All steel with safety glass windows  
and sweep-around windshield  
Door locks both sides with safety latches  
Non-glare padded instrument panel with  
ammeter, fuel, water temperature and oil  
pressure gauges

Full-width adjustable seat with Torflex  
spring construction, vinyl upholstery  
and polyurethane foam cushion  
Acoustical roof headliner

### CAB (Continued)

Rubber floor mat with sound deadening  
insulation; seat belts and shoulder  
harness anchors

Fresh air heater and defroster

Padded sun visor for driver

Ash tray; hand choke

Two-speed non-glare electric windshield  
wipers and electric washers

Chrome door mounted and inside rear  
view mirrors

### CLUTCH

10-inch 9-spring, single-plate  
Hydraulic control; vibration dampener

### COOLING SYSTEM

20-quart system capacity  
Radiator frontal area: 497 sq. inches  
Permanent type anti-freeze—20°F

### ELECTRICAL SYSTEM

12-volt 32-amp alternator  
50 amp-hr, 54 plate battery  
Fuse panel in glove compartment  
Dual stop and tail lights

Dome light; single electric horn  
Directional signals: front in parking  
lights, rear in stop lights

Traffic hazard switch  
Back-up lights

Front side marker lamps

### ENGINE

International V-266 gasoline, V-8  
Gross BHP: 154.8 @ 4400 rpm  
Gross torque: 227.1 lb/ft @ 2800 rpm  
266 cu. in. displmt; 8.4 comp ratio

### ENGINE (Continued)

Dry-type air cleaner; full-flow oil filter  
Exhaust emission control

### FINISH

Chassis—black; bumper—white  
Cab, body and wheels: choice of  
any standard IH color

### FRAME

Pressed steel channel main rails  
6½/16 × 2³¹/32 × 0.135"  
3.68 section modulus  
Formed-channel front bumper

### FUEL TANK

19-gallon, mounted under cab

### STEERING

S-8 gear, with 17-inch steering wheel  
and collapsible column

### SUSPENSION

Semi-elliptic steel leaf springs  
Front: 2½ × 46"; 2,310-lb capacity  
Rear: 2½ × 52"; 2,210-lb capacity  
Front and rear shock absorbers

### TRANSMISSION

T-13 3-speed synchromesh, direct  
Floor mounted gear shift lever  
Ratios: 2.80, 1.85, 1.00; 4.53 rev.

### WHEELS AND TIRES

Single front and rear, with spare  
7.75 × 15, 4-PR tubeless tires  
5-stud disc wheels, with 5.50 K rims  
5½" bolt circles  
Painted hub caps, front and rear

## OPTIONAL EQUIPMENT

### AXLE, REAR

RA-28 3,500-lb capacity single reduction  
with Powr-Lok limited slip differential  
Ratios: 3.31, 3.54 or 3.73

### BRAKES

Vacuum power assist

### CAB

Passenger side padded sun visor  
Left or right side arm rest  
Right side chrome mirror  
Truck type outside mirrors  
Glove compartment lock; tinted glass  
Deluxe trim package

### CAB (Continued)

Exterior trim package  
Air conditioner  
Front bucket seats with console

### CLUTCH

11-inch 9-spring

### COOLING SYSTEM

Increased capacity cooling

### ELECTRICAL SYSTEM

12-volt 61-amp alternator  
60 or 70 amp-hr battery  
Cigar lighter;  
Dual electric horns; radio

### ENGINE

Hand throttle control; automatic choke

### FRAME

Chrome front or rear bumper  
White rear bumper

### SUSPENSION

Progressive rear springs

### TRANSMISSION

T-44 4-speed synchromesh, direct

### WHEELS AND TIRES

8.15 × 15, 4-PR tubeless tires  
Deluxe chrome hub caps, front and rear

**DIMENSIONS AND WEIGHTS  
WITH STANDARD COMPONENTS**

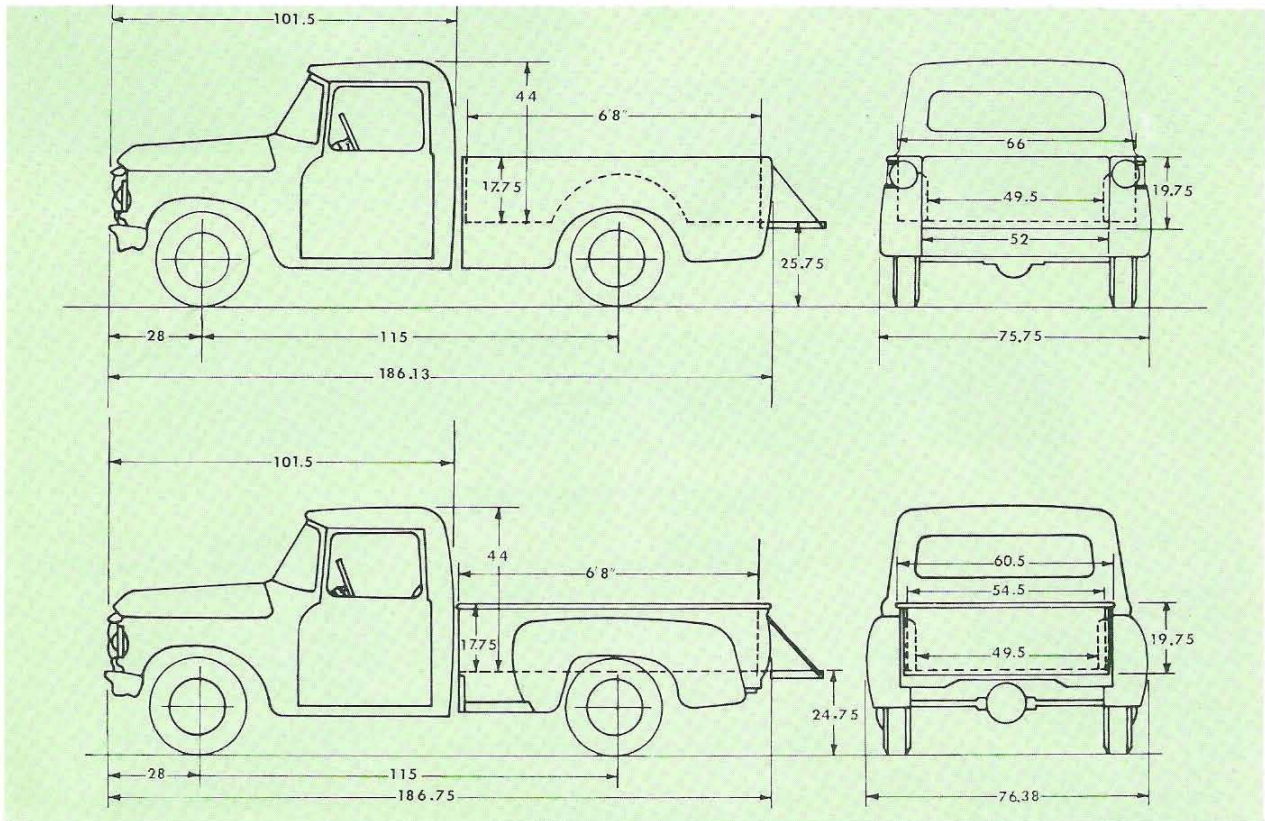

DIMENSIONS, with 7.75 × 15 TIRES									
Overall Width: 78" at front fenders			Ground Clearance: 7.0" at front axle			Frame Height at Rear Axle: 24.5" empty			
Overall Height: 68.6" at top of cab			7.1" at rear axle			21.3" loaded			
CHASSIS DIMENSIONS and WEIGHTS									
CHASSIS WEIGHTS, LBS.*				DIMENSIONS				TURNING RADIUS	
WB	Front	Rear	Total	CA	CF	AF	OAL	To Centerline of Tire	With Bumper Clearance
115"	2,105	1,350	3,455	42.0"	81.3"	39.3"	182.8"	19 ft. 4 in.	20 ft. 9 in.

\*With cab, standard equipment and tires, oil, fuel and water.

**TIRE DIMENSIONS**

TUBELESS TIRES ON DISC WHEELS		
Tire Size	7.75 × 15	8.15 × 15
Rim Size	5.50K	5.50K
Outside Width OW	69.0"	69.5"
Tread Width TW	61.4"	61.4"
Inside Width IW	53.9"	53.4"
Chain Clearance	5.1"	4.8"
Front Tread	61.4"	61.4"

In order that product improvements may be introduced at any time specifications are subject to change without notice.



INTERNATIONAL HARVESTER COMPANY • 401 NORTH MICHIGAN AVE. • CHICAGO, ILLINOIS 60611

CT-400-F. AD-4300-U7. 1-1-

ORDER AD SPEC. SHEETS ON AD-4130.

Litho in United States of America