



INTERNATIONAL®

1200 D 4x4

Vehicle illustrated may include Optional Equipment and does not necessarily include all standard equipment.

## RATINGS

### MAXIMUM GROSS VEHICLE WEIGHTS:\*

Standard.....	6,100 lbs.
With FA-25 Front Axle and Heavy-Duty Rear Springs (For 115, 119, 131 W.B. only).....	7,700 lbs.
With Heavy-Duty Rear Springs (149, 156, 164 W.B.).....	7,700 lbs.

\*Requires tires of adequate capacity.

## STANDARD EQUIPMENT

### AXLE, FRONT

FA-15 2,800-lb capacity driving (115, 119, 131WB)  
FA-18 3,500-lb capacity driving (149, 156, 164 WB)  
Hypoid single reduction  
Ratio: 4.09 to 1

### AXLE, REAR

RA-16 5,500-lb capacity  
Hypoid single reduction  
Full-floating, induction-hardened shafts  
Ratio: 4.10 to 1

### BRAKE, PARKING

Mechanical control of rear service brakes  
Foot pedal applied, finger lever released  
Total lining area: 122.7 inches

### BRAKES, SERVICE

Self-adjusting hydraulic, dual operation with warning light  
Single-cylinder single-piston front  
Single-cylinder double-piston rear  
Size: 12 x 2 $\frac{1}{8}$ " front, 12 x 2 $\frac{1}{8}$ " rear  
Total lining area: 245.5 sq. inches

### CAB

Choice of interior colors: green, blue, red or black  
All steel, with safety glass windows and sweep-around windshield  
Door locks both sides with safety latches  
Non-glare padded instrument panel with ammeter, fuel, water temperature and oil pressure gauges  
Full-width adjustable seat, with Torflex spring construction, vinyl upholstery and polyurethane foam cushion  
Acoustical roof headliner  
Rubber floor mat, with sound deadening insulation

### CAB (Continued)

Fresh air heater and defroster  
Dual padded sun visors; dual arm rests  
Ash tray; hand choke  
Two-speed electric windshield wipers and electric washers  
Seat belts; shoulder harness anchors  
Chrome door-mounted and inside rear view mirrors

### CLUTCH

11-inch diaphragm type  
Mechanical control

### COOLING SYSTEM

17 quart system capacity  
Radiator frontal area: 546 sq. inches  
Permanent type anti-freeze —20°F

### ELECTRICAL SYSTEM

12-volt 37-amp alternator  
50 amp-hr, 54-plate battery  
Fuse panel in glove compartment  
Dual stop and tail lights; back-up lights  
Dome light; single electric horn  
Directional signals: front in parking lights, rear in stop lights  
Hazard switch  
Front side reflectors

### ENGINE

International V-266 gasoline V8  
Gross BHP: 154.8 @ 4,400 rpm  
Gross Torque: 227.1 lb-ft @ 2,800 rpm  
266 cu. in. displmt.; 8.4 to 1 compr. ratio  
Dry type air cleaner; full-flow oil filter  
Aluminized muffler and short tailpipe

### FINISH

Chassis: black; bumper: white  
Hood, cab, fenders and wheels:  
choice of any standard IH color

### FRAME

Pressed steel channel main rails  
115—149" WB: 7 x 3 x 0.179"; 4.81 section modulus  
156—164" WB: 7 $\frac{1}{16}$  x 3 $\frac{3}{32}$  x 0.209"; 5.65 section modulus

Formed channel front bumper  
Underslung tire carrier

### FUEL TANK

16-gallon, mounted under cab

### STEERING

S-55 gear, with 17-inch steering wheel and energy absorbing anti-penetration column

### SUSPENSION

Semi-elliptic steel leaf springs  
Front: 2800-lb capacity (115, 119, 131 WB)  
3500-lb capacity (149, 156, 164 WB)  
Rear: 3500-lb capacity

Front and rear shock absorbers

### TRANSFER CASE

TC-141 two-speed constant mesh  
Single control lever selects high or low range and front axle declutch; permits low range operation in four wheel drive only  
Ratios: 1.93 and 1.00 to 1  
Provision for full torque PTO

### TRANSMISSION

T-24 three-speed fully synchronized  
Gear shift lever on steering column  
Ratios: 3.06, 1.55, 1.00; 3.06 rev.

### WHEELS AND TIRES

Single front and rear with spare rim  
8.00 x 16.5 6-PR truck type tires  
8-stud disc wheels, with 6.00 rims  
6 $\frac{1}{2}$ " bolt circles

## OPTIONAL EQUIPMENT

### AXLE, FRONT

FA-25 3,500-lb capacity driving with 4,480-lb springs (115, 119, 131 WB)  
Ratio: 4.09 to 1  
Warn locking hubs. Tie rod guards

### AXLE, REAR

RA-17 5,500-lb capacity single reduction with Powr-Lok limited slip differential  
Ratio: 4.10 to 1

### BODIES

6 $\frac{1}{2}$ -ft. or 8-ft Bonus-Load or regular pick-up body, with inside body tire carrier and rear side reflectors  
Travelall® body, with four side doors, rear tailgate with roll-down rear window, white rear bumper, inside body tire carrier, rear side reflectors, dual,

### BODIES (Continued)

chrome, door mounted mirrors,  
21-gallon fuel tank and long tailpipe  
Optional: Full width fold-down center seat, removable rear seat, panel-type rear doors, trim packages  
Panel body with four side doors, double rear doors, driver's individual bucket seat, white rear bumper, inside body tire carrier, rear side reflectors,  
21-gallon fuel tank and long tailpipe  
8-ft stake body with reflectors, clearance, identification and marker lamps  
9-ft stake or platform body with reflectors, clearance, identification and marker lamps

### BRAKES, SERVICE

Vacuum power assist system

### CAB

Air conditioner  
Interior trim package  
Exterior trim packages  
Nylon carpeting  
Sliding rear window  
4-door, 6-passenger Travelette cab  
Full-width or passenger seat (for panel body)  
Tinted glass  
Simulated black vinyl top  
Undercoating  
Glove box lock  
Chrome door-mounted passenger side mirror  
Truck type outside mirrors  
Camper package  
Front, bucket seats with console  
Fixed outside mirrors, single or dual

**OPTIONAL EQUIPMENT (Continued)**

**CAB (Continued)**

Super-capacity heater-defroster  
Sliding rear cab window

**CLUTCH**

11-inch HD diaphragm type  
11-inch angle link

**COOLING SYSTEM**

Increased capacity cooling

**ELECTRICAL SYSTEM**

52 or 61-amp alternator  
60 or 70 amp-hr battery  
Dual electric horns; cigar lighter  
Five front clearance and identification lamps  
Multiple electrical connector  
Front axle warning light  
Radio and antenna  
Five rear clearance and identification lamps for pickup bodies; front or rear marker lamps  
Transistorized ignition

**ELECTRICAL SYSTEM (Continued)**

Double face, fender mounted directional signals

**ENGINE**

V-304 gasoline V8  
V-345 gasoline V8  
V-392 gasoline V8  
Automatic choke  
High altitude equipment  
Hand throttle control  
Exhaust emission

**FRAME**

Underslung tire carrier; carrier lock  
Left outside tire carrier for regular pickup  
Two front tow hooks  
Chrome front and rear bumper  
White rear bumper  
Trailer hitch  
Rear step bumper with trailer hitch

**FUEL TANKS**

Auxiliary 16-gallon under right side with dash-mounted selector  
15-gallon under cab, in lieu of standard

**STEERING**

Hydraulic power assist system

**SUSPENSION**

Heavy-duty rear springs  
Auxiliary rear springs  
Heavy-duty rear shock absorbers  
Rear sway bar

**TRANSMISSION**

T-7 HD 3-speed direct synchromesh with floor-mounted control lever  
T-34 5-speed, overdrive  
T-36 5-speed, direct  
T-44 four-speed synchromesh  
T-419 HD four-speed with floor-mounted control lever  
3-speed automatic with oil cooler  
Front-mounted winch, cable and hook  
Full torque PTO for transfer case  
Transmission-mounted PTO

**WHEELS AND TIRES**

Optional tire sizes as shown below  
Bright finish hub caps, front and rear

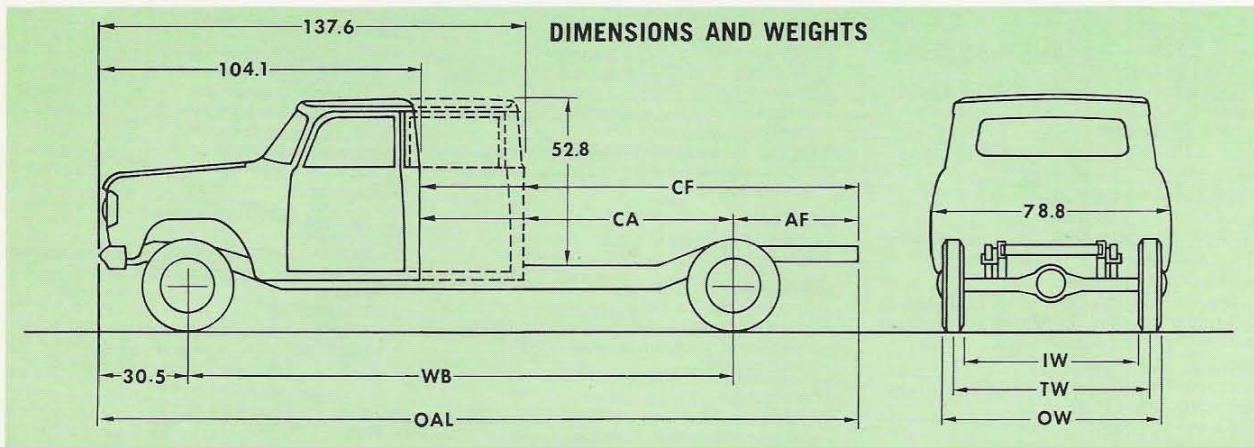

DIMENSIONS with 8.00 x 16.5 TIRES		
Overall Width: 77.6" at front fenders	Ground Clearance: 8.0" at front axle	Frame Height at Rear Axle: empty
Overall Height: 72.8" at top of cab	7.4" at rear axle	26.9" loaded

CHASSIS DIMENSIONS and WEIGHTS									
WB	WEIGHTS*			DIMENSIONS				TURNING RADIUS	
	Front	Rear	Total	CA	CF	AF	OAL	To Centerline of Tire	With Bumper Clearance
115"	2,570	1,250	3,820	41.9"	79.6"	37.7"	183.7"		
119"	2,570	1,255	3,825						
131"	2,585	1,260	3,845	57.4"	97.6"	40.2"	201.7"		
149"	2,600	1,265	3,865	75.4"	113.1"	37.7"	217.2"		
149"**	2,805	1,465	4,270	41.9"	79.6"	37.7"	217.2"		
156"	2,615	1,270	3,885	82.4"	140.0"	57.6"	244.1"		
164"**	2,830	1,475	4,305	57.4"	97.6"	40.2"	235.2"		

\*With regular cab, standard equipment, oil, fuel, and water. \*\*With Travelette Cab, standard equipment, oil, fuel, and water.

TIRE DIMENSIONS					
Tire Size	TUBELESS			TIRES AND TUBES	
	8.00 x 16.5	8.75 x 16.5	9.50 x 16.5	7.00 x 16	7.50 x 16
Rim Size	6.00	6.75	6.75	5.50F	5.50F
Outside Width OW	71.4"	72.2"	73.0"	71.3"	71.4"
Tread Width TW	63.0"	63.0"	63.0"	63.0"	63.0"
Inside Width IW	54.6"	53.8"	53.0"	54.7"	54.2"
Chain Clearance					
Front Tread	64.2"	64.2"	64.2"	64.2"	64.2"

In order that product improvements may be introduced at any time, specifications are subject to change without notice.

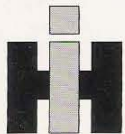

INTERNATIONAL HARVESTER COMPANY • 401 NORTH MICHIGAN AVE. • CHICAGO, ILLINOIS 60611

CT-400-G. AD-4239-W8. 11-1.

ORDER AD SPEC. SHEETS ON AD-4130.

Litho in United States of America