

'75 International. The Other Pickup.



Bonus-Load 150. Meet the all-around, all-American pickup from International. This truck-tough, smooth riding performer will make life easier for you. For fun. Work. Personal transportation. Shopping. Whatever. It handles so easily, your wife will love driving it.

The Other Pickup has a wider track than any pickup on the road: tread width—67 inches. Plus independent coil-spring front suspension, rugged U-channel frame, big rear leaf springs, and a carlike ride. And you get a choice of a 6½- or 8-foot pickup box. Standard features include electronic ignition, power front disc brakes, closed cooling system, and heavy-wall exhaust pipes with an aluminized muffler.

Selective 4-wheel drive. Add International's selective 4-wheel drive, and you're set for some of the toughest kind of off-road driving, and able to maintain stability and control on iced or rain-slicked highways.

Selective 4-wheel drive with locking hubs means you use it only when you need it. There's less wear and tear on front drive components. And you save gas when you're not using 4-wheel drive because the engine isn't turning mechanical parts in the front axle.

Order selective 4-wheel drive with automatic or manual locking hubs: with automatic locking hubs you can engage the driving front axle from inside your pickup .

Bonus-Load 200. Put a camper on The Other Pickup, and get away for a weekend, a week, as long as you like. It's built to take extra-heavy cargo over the roughest kind of terrain. It has high-capacity axles, suspension, and tires, and you can get up to 9000-GVW rating. The pickup box has double-sidewall strength, and the hood is double-paneled for rigidity and resistance to flutter.

Don't get the idea the 200 is just for carrying campers. It can do everything our 150 Series can do; it's just designed to handle more load. Your International dealer will help you meet your needs.

Travelette. Now you can combine work and play in one multi-purpose vehicle. The Travelette is part wagon, part truck, with the best parts of both. On top of a sturdy truck frame and suspension, there's a wagonlike body that holds up to six adults comfortably . . . plus a full size pickup box.

The Travelette is ideal for families who like to pull a big fifth-wheel trailer or tote a big camper. Order your Travelette with a 6½- or 8-foot pickup box. And every box features a one-hand, swing-down tailgate for easy loading.



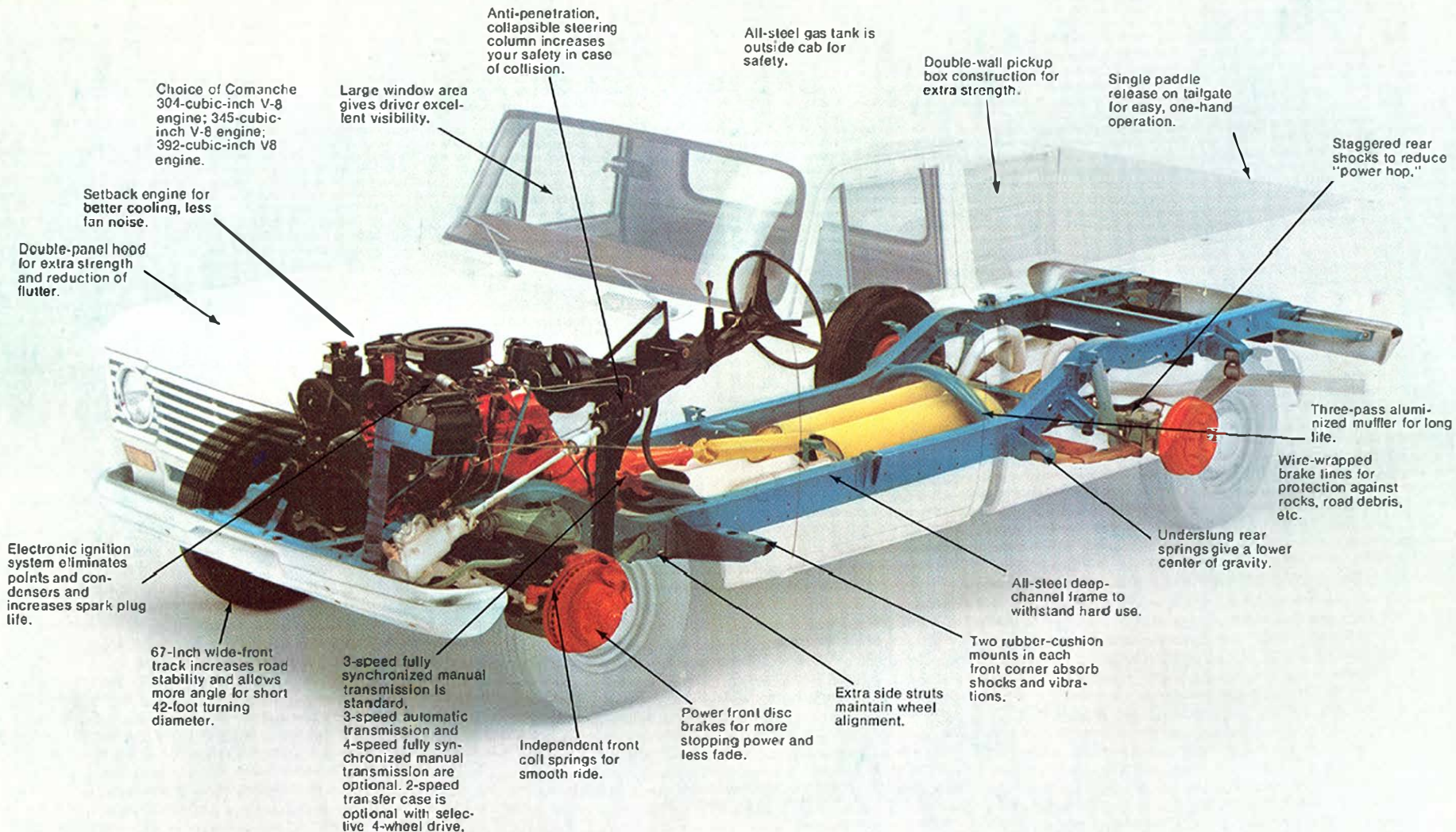

Widest-riding Pickup. A 67-inch front track gives The Other Pickup the widest track of any pickup on the road. The wider wheel location allows more angle for short 42-foot turning diameter. We combine the wider track with independent coil spring suspension for improved roll stability, handling, and riding performance.

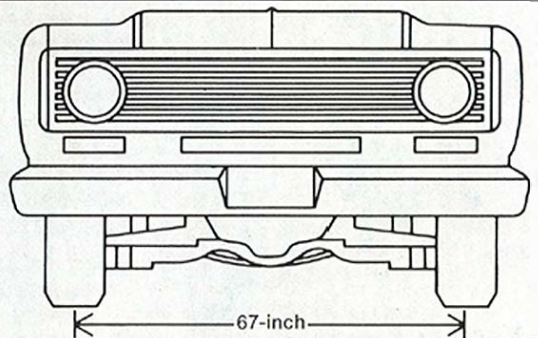

Engineered for the tough life. The Other Pickup is engineered for performance, endurance, and reliability. Whether you drive in-town, on-highway, or off-road, it's built to take lots of punishment. Standard features include heavy-duty components in chassis and engine. Tough U-channel steel frame. Heavy-duty springs, axles, shocks, and brakes. Precision-balanced crankshaft and hydraulic lifters. Oil pumps with cast iron housings. A close look at the photographic illustration will show you why The Other Pickup is truck-tough yet rides like a car.

The Other Pickup helps you get a lot more out of life.

It's built like a truck, drives like a car, and lets you have as much fun as a sports car. Whether you're loading up food and beverages for a family picnic, driving off-road to catch some scenery, or throwing on a couple of motorcycles, bicycles, or surfboards for outdoor sport, The Other Pickup helps make life a lot more fun.

But The Other Pickup has a practical side. It's the perfect vehicle for hauling a new freezer home from the appliance store. Or for borrowing and returning a tractor mower in case yours is out for repairs. For carrying a few dozen sheets of plywood or plywood paneling home for that modernization job.

For work, play, or just plain personal transportation, no other vehicle will give you the versatility, satisfaction, comfort, and durability of The Other Pickup.



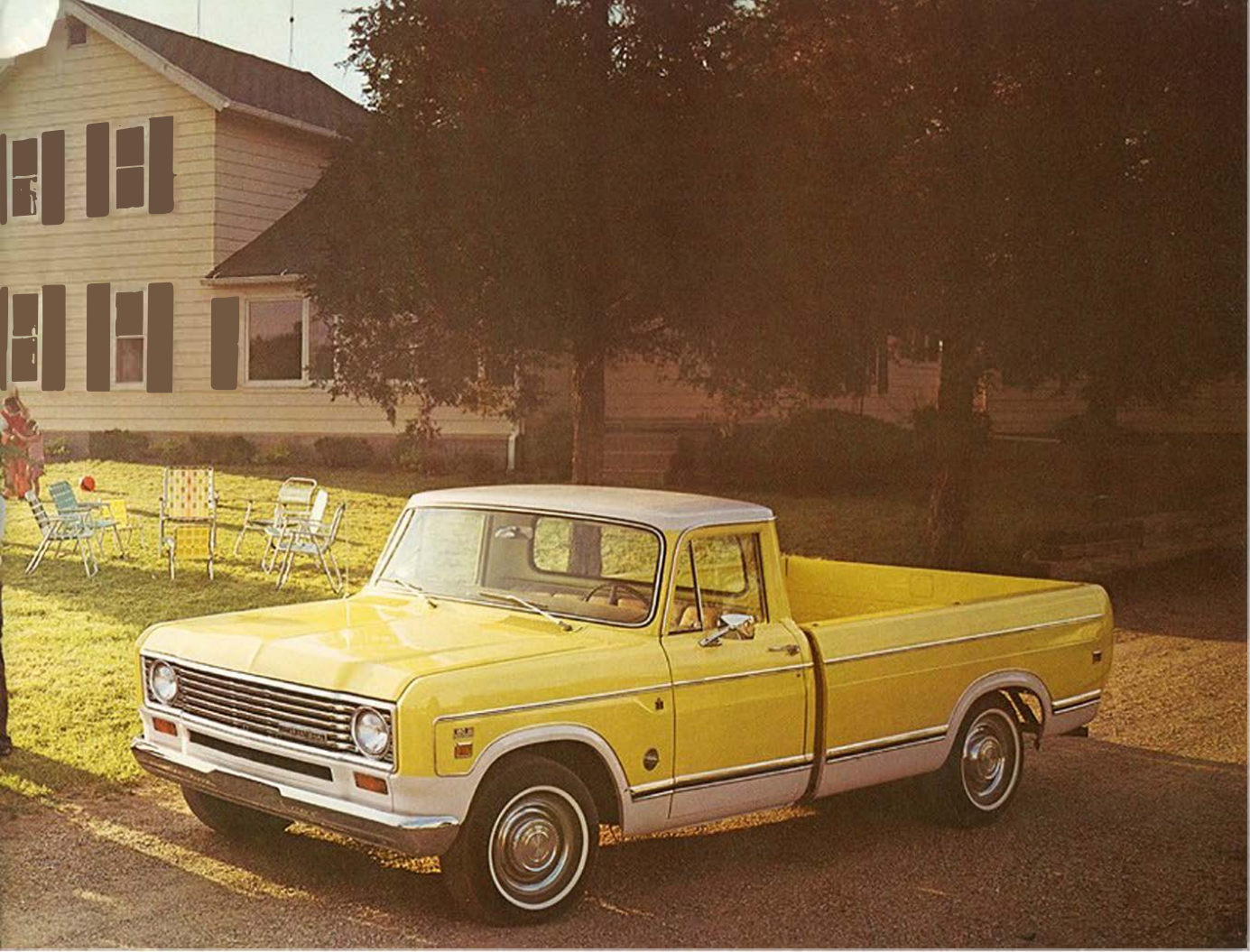

Interior trim.



Sage.



Dark Red.



Dark Blue.



Jet Black.

Exterior color accents.



Deluxe exterior. Bright-finish side trim molding with inset black trim; bright-finish windshield, vent wings, drip molding; bright-finish wheel covers on Model 150 and bright-finish hub caps on Model 200; chrome front bumper; bright-finish door-mounted rearview mirrors and stop/tail light bezel; aluminum tailgate insert.



Custom exterior. Two types of custom exterior trim. One type is the color of your choice in the side body panels. The other type is any color you want under the rocker panel trim strip and extending along the wheel wells and across the lower front of the pickup.



Optional roof. Dress up your pickup with a spiffy black or white simulated vinyl roof. Or if you prefer, get a roof painted in the color of your choice.

Inside The Other Pickup. Interiors are a pretty personal thing. So we want you to have the option of selecting an interior that suits your requirements and taste. That's why we offer you a choice of three interiors and four interior trim colors. We also offer a seating option of bucket seats which are not shown. Bucket seats are available with standard, deluxe, and custom interiors. A center storage console is included with bucket seats at no extra cost.



Custom interior. (Above two photos.) Big-car luxury. Thick nylon carpet for floor and kick panels. Electric clock. Day/night mirror. Dual electric horns. Padded horn button. Parking brake warning light. Plus a lighting package that's tops in convenience and utility: underhood light, map light, glove box light, lighted control knobs, lighted ash tray, and rear cargo area light.

Standard interior. The foam-filled bench seat is upholstered with soft, long-wearing vinyl in a choice of four eye-pleasing, restful colors. Seat and cab interior are engineered to give up to three adults plenty of head, shoulder, hip, and leg room. You get an easy-to-read, fully instrumented padded dash, dual full-sized padded armrests and sunshades, roomy glove box, paddle door release handles, wide-angle breakaway inside mirror, and a quiet, efficient fresh air heater/defroster system.



Deluxe interior. Bench seat is covered with durable, easy-to-clean nylon trimmed in rich vinyl. Complete with color-keyed vinyl floor covering and soft-padded vinyl door panels. It also features door-operated dome light, cigar lighter, coat hook, and glove compartment lock.

Options to make it your personal pickup. Nobody knows better than you how much utility, convenience, and luxury you want in a pickup. We have all the options you need to customize your pickup to your requirements. After you decide on the personal options, like exterior and interior colors, type of radio, air conditioning, selective 4-wheel drive, power steering, auto-cruise control, etc., your International truck specialist is ready to help you select the proper V-8 engine, transmission, axle ratio, and GVW package. At International, we believe in matching the pickup to the man. We put the right truck in the right hands—yours.

Air conditioning. Relieve summer heat. The Other Pickup's air conditioning system provides fast, quiet, constant cooling.

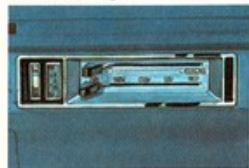

Anti-skid brakes. If you start to skid when you apply brakes, anti-skid system automatically takes over and keeps the wheels from locking to assure a safer straight line stop.



AM or AM/FM radios. Take your choice of great sounding AM or AM/FM factory installed radios. For added enjoyment, ask your dealer to install an 8-track stereo tape player.



Selective 4-wheel drive/2-speed transfer case. We believe selective 4-wheel drive with locking hubs is the most practical and economical all-wheel drive system you can buy. You use it only when you need it. Which means less wear and tear on front driving components. And you save gas when you're not using 4-wheel drive because the engine doesn't have to turn mechanical parts in the front axle. The 2-speed transfer case gives you the slow-speed deep-reduction capability you need for climbing steep grades, snow-plowing, hauling heavy loads over rough terrain, or driving through deep mud, sand, snow, or ice.



Sliding rear window. Not only do you get more ventilation when you want it, but it makes communications between cab and camper much easier. Included in camper special option package.



Rear step bumper. Heavy-duty step bumper with trailer-hitch mount and trailer wiring. Makes it easier to get in and out of cargo bed when loading and unloading.



Camper special package. Just the thing when you want to get away from the crowd. A complete package that includes heavy-duty cooling and heavy-duty electrical components. Rear sway bar. Underslung tire carrier. Auxiliary fuel tank. 61-amp alternator and 73-amp/hr battery. Dual exhaust with long tail pipes. Sliding rear window. Dual low profile mirrors. 7-way camper wiring (less connector). Camper decal.



Tilt steering wheel. Seven positions for true driving comfort. Just flip a lever, and you can adjust your steering wheel to your most comfortable driving position. Adjust it again for easier entry and exit.



Slide-in toolbox. Add the convenience of this weather-resistant, made-to-fit toolbox. Built-in paddle locks. Dealer installed.



Camper insert stabilizer. Maximizes control of slide-away and forward- and backward-lurching motions. Attaches permanently to overhang of camper, and swings up and locks out of the way for storage. Adjustable length of 26 inches to 38 inches. Dealer installed.



Auto-cruise speed control. Automatically maintains speed at rate you prefer. Ideal for throughway driving. Gas-saver on long trips.



Auxiliary fuel tank. Extend the range of your pickup by ordering an auxiliary fuel tank.



Cargo light. Now you can load or unload at night with perfect safety. Part of lighting package included with custom interior.

Other options and accessories. Underslung tire carrier. Optional axle ratio. Automatic transmission. Power steering. Trailer-towing package. Tonneau cover. Pickup rails. Bumper guards.

Specifications.

Series	150		200		150-4x4		200-4x4		260 TRAVELETTE	
	STANDARD	OPTIONAL	STANDARD	OPTIONAL	STANDARD	OPTIONAL	STANDARD	OPTIONAL	STANDARD	OPTIONAL
GVW Ratings (lbs.)	6200	6500	6700	7100, 7500, 8200, 9000	6200	6500	6900	7300, 7700, 9000	8200	9000
Engines	V8's V-304A	V-345A V-392	V-304A	V-345A V-392	V-304A	V-345A V-392	V-304A	V-345A V-392	V-304A	V-345A V-392
Clutch	11" Diaphragm	11" Angle Link	11" Diaphragm	11" Angle Link	11" Diaphragm	11" Angle Link	11" Diaphragm	11" Angle Link	11" Diaphragm	11" Angle Link
Front Suspension	Independent Coil Spring		Independent Coil Spring		Driving Hypoid w/Leaf Springs		Driving Hypoid w/Leaf Springs		Independent Coil Spring	
Cap. (lbs.)	3200	—	3500	—	3400	—	3500	—	4000	—
Springs—Cap. (lbs.)	3150	—	3450	3800	3400	—	3500	—	3150	3800
Shock Absorbers	1" Diam.	1 1/2" Diam.	1 1/2" Diam.	1 1/2" Diam.	1 1/2" Diam.	1 1/2" Diam.	1 1/2" Diam.	1 1/2" Diam.	1 1/2" Diam.	1 1/2" Diam.
Stabilizer Bar	—	Front & Rear	—	Front & Rear	—	Rear	—	Rear	—	Front & Rear
Rear Suspension	Semi-Floating Hypoid Single Reduction		Full Floating Hypoid Single Reduction		Semi-Floating Hypoid Single Reduction		Full Floating Hypoid Single Reduction		Full Floating Hypoid Single Reduction	
—Axle Type	—	—	—	—	—	—	—	—	—	—
Cap. (lbs.)	3600	3800	5500	7500	3600	3800	5500	7500	5500	7500
—Ratios	3.31	3.07 3.54 3.73, 4.10	3.54	3.73, 4.10 4.30, 4.56 4.88	3.31	3.07 3.54 4.10	3.54	3.73, 4.10 4.30, 4.56 4.88	3.54	3.73, 4.10 4.30, 4.56 4.88
Springs—Type	Leaf Springs	Leaf Springs w/Auxiliary	Leaf Springs	Leaf Springs w/Auxiliary	Leaf Springs	Leaf Springs w/Auxiliary	Leaf Springs	Leaf Springs w/Auxiliary	Leaf Springs	Leaf Springs w/Auxiliary
Springs—Cap. (lbs.)	3300	3500	4000	4800, 6300	3300	3500	4000	4880, 5600	4880	6300
Shock Absorbers	1" Diam.	1 1/2" Diam.	1" Diam.	1 1/2" Diam.	1 1/2" Diam.	1 1/2" Diam.	1 1/2" Diam.	1 1/2" Diam.	1 1/2" Diam.	—
Brakes	Front/Rear	Power Disc/Drum	Power Disc/Drum	Power Disc/Drum	Power Disc/Drum	Power Disc/Drum	Power Disc/Drum	Power Disc/Drum	Power Disc/Drum	Power Disc/Drum
Electrical	Battery-Amp.	55	73	55	73	55	73	55	73	55
Alternator-Amp.	37	61	37	61	37	61	37	61	37	61
Fuel Tank	Nominal Capacity (gal.)	16	16 Gal. Auxiliary	16	16 Gal. Auxiliary	16	16 Gal. Auxiliary	16	16 Gal. Auxiliary	16
Steering	Type	Manual	Integral Power	Manual	Integral Power	Manual	Integral Power	Manual	Integral Power	Manual
Transmissions	3-Speed Synchr. Manual	4-Speed Synchr. Manual	3-Speed Synchr. Manual	4-Speed Synchr. Manual	3-Speed Synchr. Manual	4-Speed Synchr. Manual	3-Speed Synchr. Manual	4-Speed Synchr. Manual	3-Speed Synchr. Manual	4-Speed Synchr. Manual
Transfer Case	—	—	—	—	Single-Speed "Silent Drive"	Two-Speed Gear Drive	—	—	—	—
Tires	Tubeless Tires—Sizes	H78x15 LRR PC	800x16.5 LRC	H78x15 LRR PC	800x16.5 LRC	800x16.5 LRC	800x16.5 LRC	800x16.5 LRC	800x16.5 LRC	800x16.5 LRC

*Oversize tires available based on gross vehicle weight ratings.

Engine Specifications	Comanche V-304	V-345	V-392
Displacement (cu. in.)	304	345	392
Bore & Stroke (in.)	3 7/8 - 3 1/2	3 3/4 - 3 3/8	4 1/8 - 3 3/8
Compression Ratio	8.19 to 1	8.05 to 1	8.02 to 1
SAE Net Horsepower @ RPM	141 @ 4000	158 @ 3600	172 @ 3600
SAE Net Torque (lbs./ft.) @ RPM	243 @ 2400	288 @ 2000	288 @ 2400

Model	1975 International® Pickup® Specifications		150		200		4 x 4		260		Travelette	
	4 x 2	4 x 4	4 x 2	4 x 4	4 x 2	4 x 4	4 x 2	4 x 4	4 x 2	4 x 4	4 x 2	4 x 4
Wheelbase	119", 132"	119", 132"	119", 132"	119", 132"	119", 132"	119", 132"	119", 132"	119", 132"	119", 132"	119", 132"	119", 132"	119", 132"
Overall Length	204 7/8"	204 7/8"	204 7/8"	204 7/8"	204 7/8"	204 7/8"	204 7/8"	204 7/8"	204 7/8"	204 7/8"	204 7/8"	204 7/8"
Overall Width	79 7/8"	79 7/8"	79 7/8"	79 7/8"	79 7/8"	79 7/8"	79 7/8"	79 7/8"	79 7/8"	79 7/8"	79 7/8"	79 7/8"
Tailgate Opening	65"	65"	65"	65"	65"	65"	65"	65"	65"	65"	65"	65"
Front Tread	67 1/4"	64 6/8"	67 1/4"	64 6/8"	67 1/4"	64 6/8"	67 1/4"	64 6/8"	67 1/4"	64 6/8"	67 1/4"	64 6/8"
Rear Tread	65 2"	65 2"	65 2"	65 2"	65 2"	65 2"	65 2"	65 2"	65 2"	65 2"	65 2"	65 2"
Ground Clearance (minimum)	6.8" fr. & 7.1" rr.	8.0" fr. & 7.7" rr.	7.7" fr. & 7.0" rr.	8.0" fr. & 7.3" rr.	7.7" fr. & 7.0" rr.	8.0" fr. & 7.3" rr.	7.7" fr. & 7.0" rr.	8.0" fr. & 7.3" rr.	7.7" fr. & 7.0" rr.	8.0" fr. & 7.3" rr.	7.7" fr. & 7.0" rr.	8.0" fr. & 7.3" rr.
Turning Diameter (minimum)	40' 5"	45' 8"	41' 2"	46' 4"	42'	44' 2"	41' 2"	46' 4"	42'	44' 2"	41' 2"	46' 4"

Exterior colors.



Bimini Blue Metallic.



Burnished Gold Metallic.



Red.



Flame Red.



Dark Green Affair.



Gold Metallic.



Omaha Orange.



School Bus Yellow.



Glacier Blue.



Winter White.



Sunburst Yellow.



Pewter Metallic.



Grenoble Green.



Dark Brown Metallic.



Buckskin.



Fire Orange.



Terra Cotta.



Specifications, descriptions, photographic and illustrative material in this literature are as accurate as known at time of publication, but are subject to change without notice. Photographs and illustrations may include optional equipment and accessories and may not include all standard equipment.