

DEDICATED TO THE FREE SPIRIT

IN JUST ABOUT EVERYONE



1976 BUICK.



Dedicated to the Free Spirit in just about everyone.

The automobile is an amazing device. Not so much for its mechanical intricacies, but for what it does for its owner.

We are mobile creatures, but our legs limit us. The automobile helps free us. To roam, to travel, to explore what lies beyond the next mountain range. And to do so whenever we want. In what other device can you flee the confines of

the city and, an hour later, be parked by a trout-filled stream?

A Buick is a special sort of automobile because it offers this emancipation with a tremendous amount of style.

As you will discover, the joy of the 1976 Buicks is that they are dedicated to the free spirit in just about everyone. Students, parents, businessmen, businesswomen, farmers, lawyers, house-

wives, doctors—there's a Buick for just about everyone. They are young, free, fun. They are cars you ought to get to know.

The 1976 Buicks: dedicated to the free spirit in just about everyone.



About this catalog.

Deciding what kind of car to buy in this day and age isn't easy. To make an intelligent decision you need more information than ever before. Which is why this catalog is so important to you. It's an unusual catalog, actually—and innovative, hopefully. Its purpose is to give you as much information about the 1976 Buicks as possible. To do this we've divided the catalog into two sec-

tions. The front section, printed in full color, is a basic introduction to each of the seven Buick car lines. The second section, in the back, is the Buick Buyer's Guide. In it we probe the story of the 1976 Buicks in depth. Into what makes a Buick a Buick—the engineering, design and materials involved. Because we want you to have a truer understanding of these very special cars.

CONTENTS.

- 4 THE 1976 SKYHAWK.
6 The Skyhawk cockpit.
-
- 8 THE 1976 SKYLARK.
12 Skylark inside.
14 A closer look at Skyhawk and Skylark.
-
- 16 THE 1976 CENTURY.
24 Century inside.
26 A closer look at Century.
-
- 28 THE 1976 RIVIERA.
30 The Riviera cockpit.
-
- 32 THE 1976 LeSABRE.
36 LeSabre inside.
-
- 38 THE 1976 ELECTRA.
42 Electra inside.
-
- 44 THE 1976 ESTATE WAGON.
46 Estate Wagon inside.
-
- 48 A closer look at Riviera, LeSabre,
Electra and Estate Wagon.
-
- 50 THE 1976 BUICK MODEL LINE-UP.
-
- 51 **1976 BUICK BUYER'S GUIDE**
-
- 52 WELCOME TO THE BUYER'S GUIDE.
-
- 52 WHAT MAKES A BUICK, A BUICK.
52 Gentlemen, start your engines. (Ladies invited).
53 Buick's Fuel Economy System.
We have good reason for calling it that.
54 When you buy a 1976 Buick, you're buying
a car that requires less routine maintenance.
54 The chassis. The dictionary says it's a frame.
We say it's a whole lot more.
55 Buick. The body beautiful.
55 Important improvements in the 1976 Buicks.
56 Every new Buick is a tested Buick.
-
- 57 THE SELECTION OF YOUR CAR:
AN IMPORTANT DECISION.
-
- 58 A LOOK AT OPTIONS.
-
- 60 THE 1976 SKYHAWK:
Features, specifications, Ordering Guide.
-
- 62 THE 1976 SKYLARK:
Features, specifications, Ordering Guide.
-
- 64 THE 1976 CENTURY:
Features, specifications, Ordering Guide.
-
- 66 THE 1976 RIVIERA:
Features, specifications, Ordering Guide.
-
- 68 THE 1976 LeSABRE:
Features, specifications, Ordering Guide.
-
- 70 THE 1976 ELECTRA:
Features, specifications, Ordering Guide.
-
- 72 THE 1976 ESTATE WAGON:
Equipment, Ordering Guide.
-
- 73 1976 BUICK SAFETY FEATURES.
-



ABOUT THE COVER.

"The Free Spirit Hawk,"
the woodsculpture pictured on the cover
was carved by Georg Keilhofer of
Frankenmuth, Michigan.
Mr. Keilhofer is formerly of
Berchtesgaden, West Germany.

The 1976 Skyhawk.

Ah, the emotions a well-turned-out road car inspires: Affection. Romance. Self-confidence. Determination. Freedom. You feel them all the first time you experience Buick Skyhawk.

There's an immediate sense of chemistry between you and it. Perhaps it's the rectangular headlamps, or the fastback roofline, or that sloping, bulging hood. Whatever it is, you must get inside.

Its high-backed buckets, center console and bold instrumentation are hardly a disappointment. "I've got to drive this car," you say.

So off you go. The new you. Experiencing the fun of driving again. Downshifting into corners,

upshifting as you pass. The floor-mounted gear lever falls readily to hand. The steering wheel is small and comfortably angled. And, as you watch the tachometer needle climb, and feel the power of the Buick V-6, you begin to understand why this car inspires such emotion. In one sense, Skyhawk is a practical machine: economical, V-6 powered. In another, it contains all the spirit and enthusiasm you could ask for. This duality is something you've missed—something few cars have today. And we're willing to bet it's a quality a lot of people like you are looking for in a car right now.

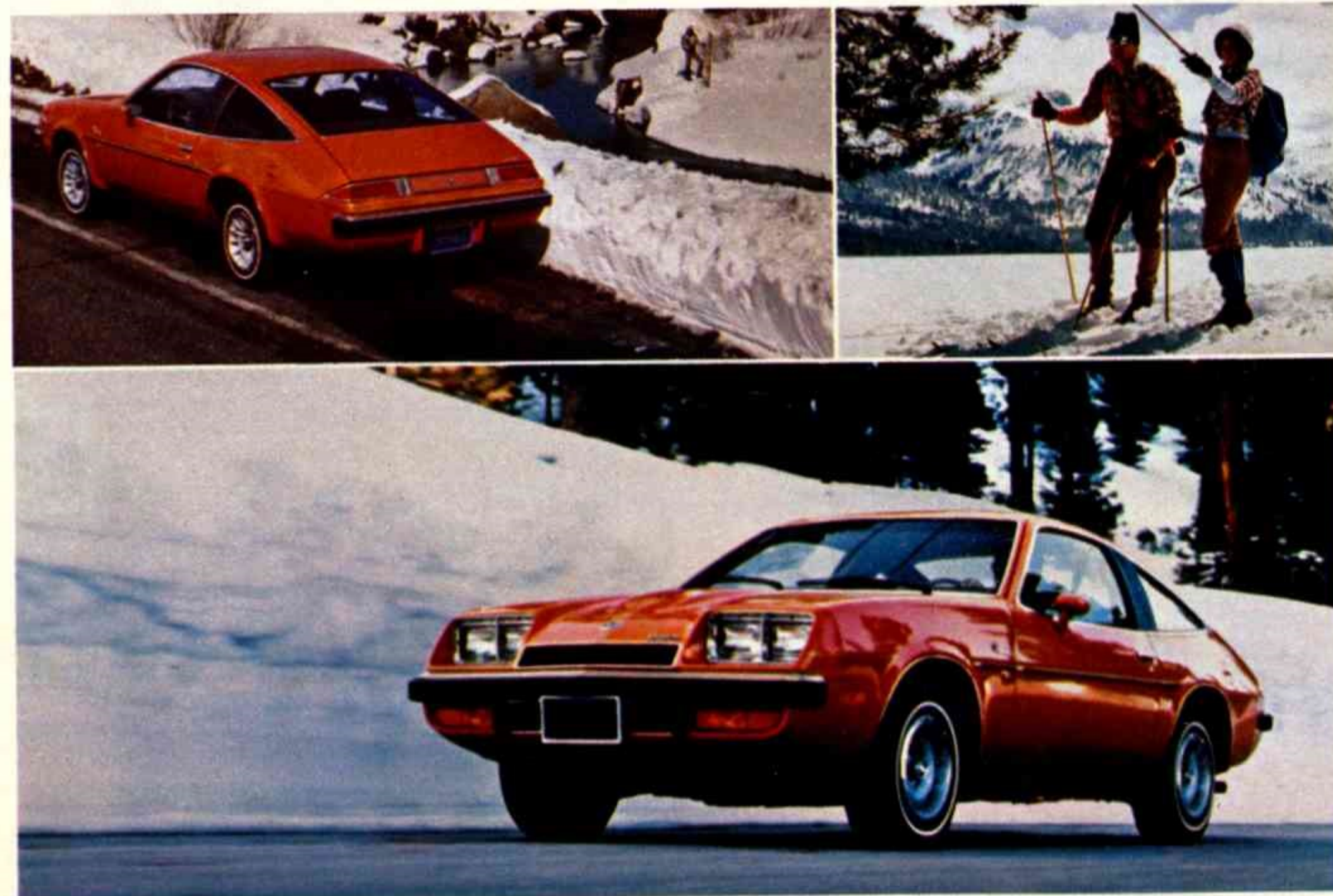

Skyhawk. The epitome of the new small Buicks. Exciting. Economical. V-6 powered. With a slippery, aerodynamic look.

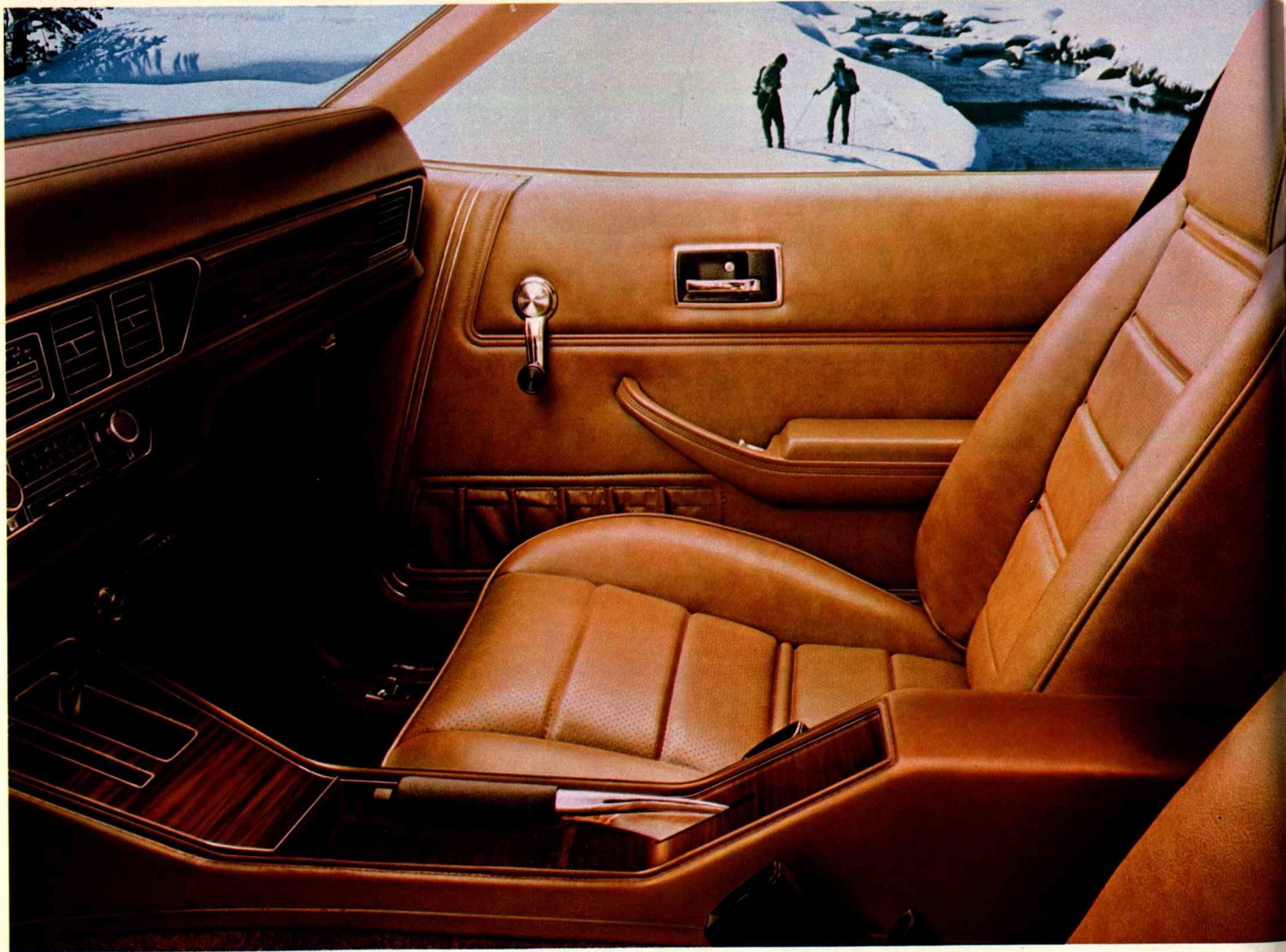

Skyhawk's tall bucket seats, center console and European-style handbrake beckon you.

The Skyhawk cockpit.

A road car can be as aerodynamically shaped and as mechanically exciting as a Formula 1 racer, but if its cockpit area isn't well thought-out, the car loses much of its appeal. Which is why considerable attention is paid to Skyhawk's "driving quarters."

To begin, Skyhawk's seating is arranged in 2-plus-2 fashion. The seats themselves are of full-foam construction, which provides good back and leg support. And they're dished just enough to hug you through turns. Information about the car's performance is sent to the driver through large, easy-to-read instrumentation. There's a 7,000-rpm tachometer, a km/h-mph speedometer, an ammeter, an electric clock, and monitors for fuel level and engine temperature. And mounted in a console between the two bucket seats, is the gear shift lever, connected to your choice of three transmissions: the standard 4-speed manual, the available automatic, or our new 5-speed overdrive manual—more about that on page 14.



Skyhawk instrument panel



Skyhawk cloth and vinyl bucket seats

Interior Trim Availability

Skyhawk 'S' Hatchback Coupe	S	S
Skyhawk Hatchback Coupe	S	S

S—Standard

Cloth and vinyl buckets
Vinyl buckets

The 1976 Skylark.

One of the nicest things about buying a car today is that you can buy a small car and enjoy a few luxuries at the same time. The car is our compact Skylark, the only American compact powered by a V-6 engine.

Skylark is a bridge. A bridge joining two seemingly incompatible worlds. A car with many of the inherent qualities of larger Buicks: style, comfort, engineering excellence, rigorous attention to detail. Plus the qualities inherent in a small car: economy, maneuverability, and moderate purchase price.

There are seven Skylark models—from the low-priced

Skylark 'S', to the sporty Skylark S/R, all the way to the European-inspired Skylark Sedan.

The standard powerplant is Buick's 3.8-litre V-6, which sends you and Skylark on your way with spirit and economy.

Other items of interest you'll find standard on Skylark are High-Energy Ignition, front disc brakes, computer-selected springs, a hefty front stabilizer bar and large, comfortable, full-foam seats.

As you can see, Skylark is anything but an ordinary small car; and yet the price is the lowest you'll find on any car with the Buick name.



This is the Skylark S/R Hatchback Coupe, with over 28 cubic feet of stowage-space in back. It's also a ball to drive.



The Skylark Coupe. Its standard Buick V-6 pinches on gas, not excitement.

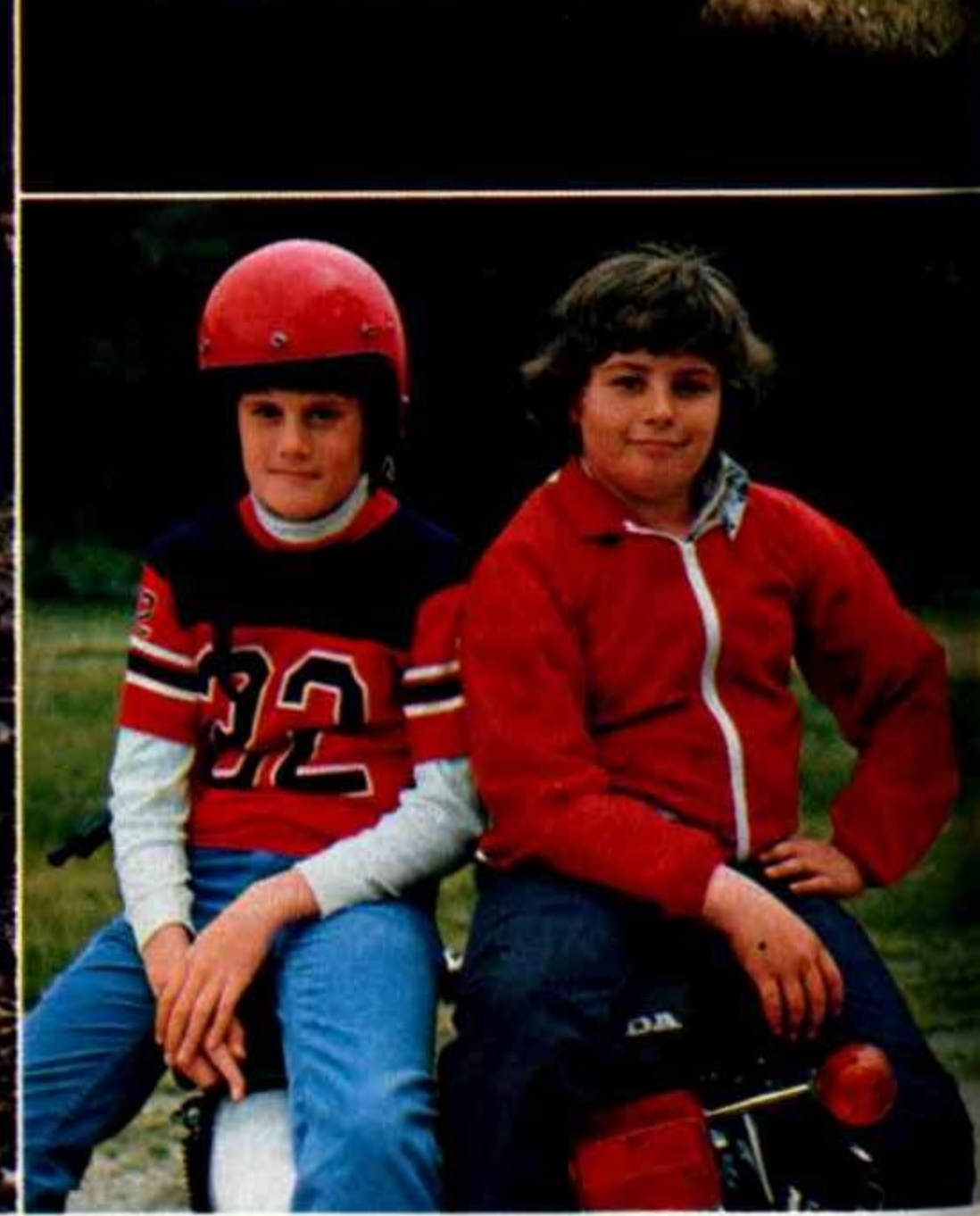
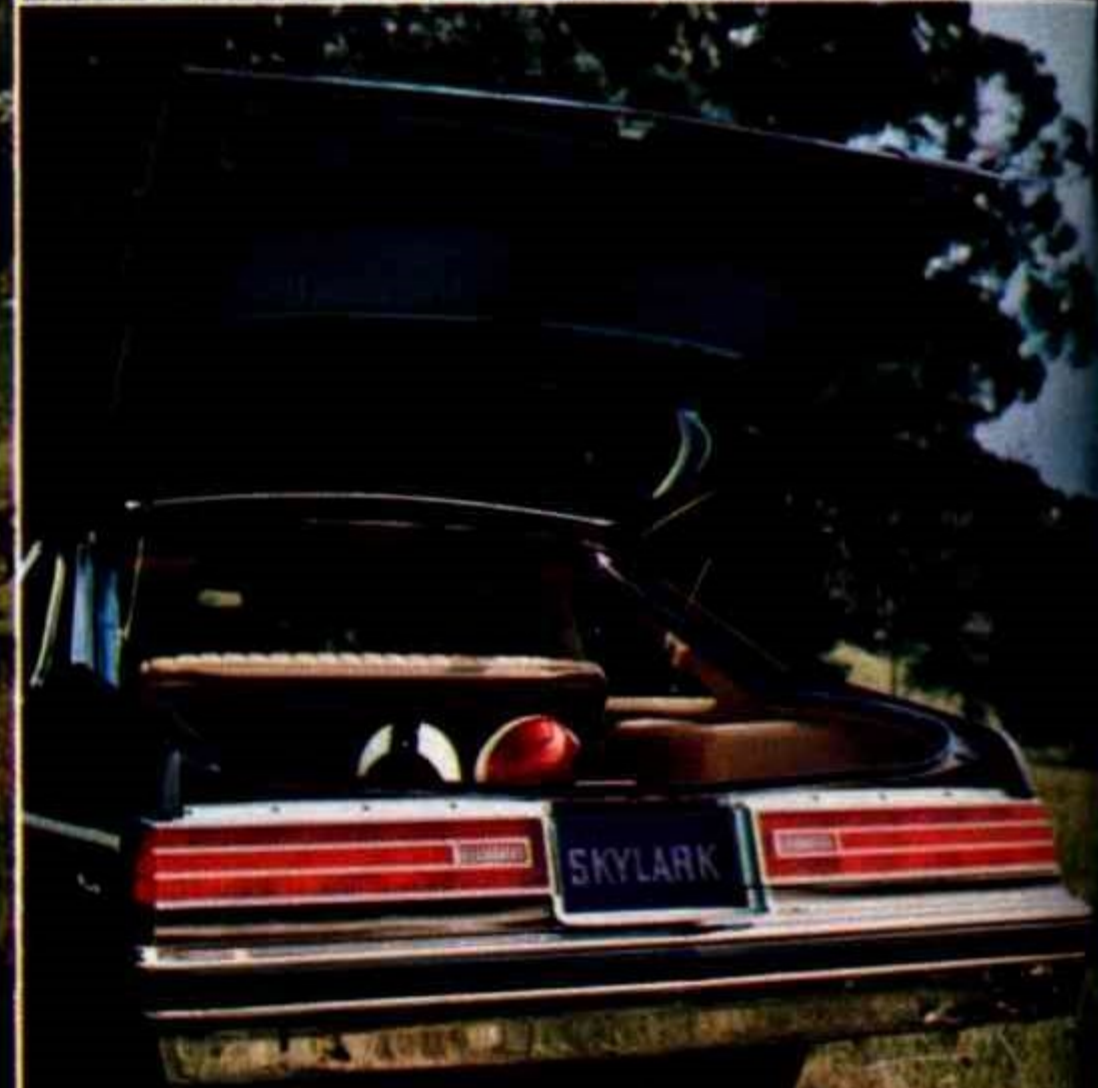
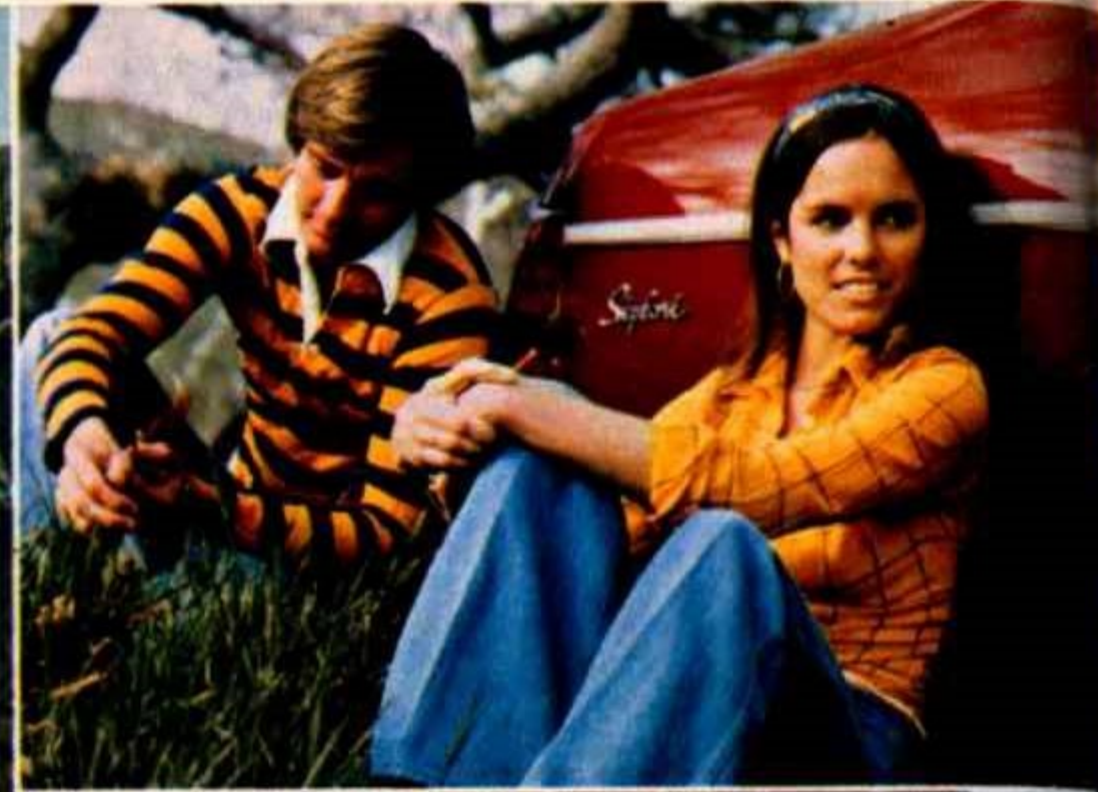

In the foreground, the European-inspired Skylark Sedan. The Skylark Hatchback is shown in background.



You don't drive a Skylark S/R—you wear it.

Skylark inside.

Pictured at left is the Skylark S/R cockpit, an environment you'd swear was aircraft-inspired.

Large, black dials tell the driver his speed, mileage, fuel level, and help keep him abreast of what's happening in the engine compartment. The controls are well-marked and close at hand. And per European touring cars, the turn signal lever doubles as a headlight dimmer switch.

Skylark S/R's seating is similarly inspired. Thick, ribbed-velour bucket seats firmly cradle back and legs. (And for the navigator's pleasure, the right seat reclines.) Separating the front seats is a large console where the gear shift lever is mounted. The console also offers bins for convenient stowage of driving glasses, gloves, etc. Maps can be stashed in pockets built into each of the doors.



Skylark instrument panel



Skylark 'S' vinyl bench seat



Skylark cloth and vinyl bench seat



Skylark custom cloth and vinyl bench seat



Skylark vinyl bucket seats

Interior Trim Availability

Skylark 'S' Coupe	S
Skylark Coupe	S S A A A
Skylark Hatchback	S S A A A
Skylark Sedan	S S A A A
Skylark S/R Coupe	S
Skylark S/R Hatchback	S
Skylark S/R Sedan	S

S—Standard A—Available

Vinyl bench seat
Cloth and vinyl bench seat
Vinyl buckets
Custom cloth and vinyl bench seat
Custom vinyl bench seat
Cloth and vinyl buckets

A closer look at Skyhawk and Skylark.

SKYHAWK 'S':

Last year, mid-way through the model year, we introduced a low-priced edition of the Skyhawk called the Skyhawk 'S'. Well, because it was such a popular little car, for 1976, we've kept the Skyhawk 'S' and made it a regular member of the Skyhawk line-up.

The 'S', of course, doesn't have all of Skyhawk's standard features—but it's still a road car with a tremendous amount of spirit. Naturally, you can specify any of the available options you want on your Skyhawk 'S'. That way, you can sort of build your

Skyhawk the way you want it. If you've got more free spirit than money in the budget, Skyhawk 'S' might be just your style.

5-SPEED OVERDRIVE TRANSMISSION.

From the beginning, Skyhawk has been both economical and fun. But with the new 5-speed transmission, it's even better.

It's light. Tight. And fifth gear is an overdrive. Which means you cruise even more economically because the engine has to turn fewer rpm's to move the car a given distance.

Joining the new Skyhawk 5-speed as available equipment is a

3-speed Turbo Hydra-matic automatic transmission. The standard transmission on Skyhawk and Skyhawk 'S' is a 4-speed manual.

SKYHAWK UNDER GLASS.

Worship the sun? Then order your Skyhawk with Astrorooft. It's a smoke-colored glass section fitted into the roof. Highlighted by a wide, brushed aluminum band that runs over the top of the car. Beautiful.

EVERY SKYHAWK IS A HATCHBACK.

One of the nicest aspects of Buick

Skyhawk is its aft section. Flip the rear seat down and there's nearly 28 cubic feet of stowage area. Skyhawk not only takes you where you want to go with a great deal of vigor, it gives you plenty of room for the fun gear you want to take with you.

SKYHAWK'S FREEDOM BATTERY.

Skyhawk's electrical system is energized by a new, aptly-named "Freedom Battery." It's entirely maintenance-free. You never have to add water or clean its terminal posts. The Freedom Battery is standard on Skyhawk. And available on all other Buicks.

SKYLARK 'S':

There's a less-expensive edition of the Skylark Coupe. Skylark 'S'. Skylark 'S' doesn't have all of Skylark's standard equipment, but it's still all free spirit.

SKYLARK ECONOMY FEATURES.

Buick Skylark is first and foremost an economy car. Thanks mostly to its standard 3.8-litre V-6 engine. As the only V-6 engine designed and built in America, the Buick V-6 shares the efficiencies of a V-8 (short piston stroke, short crankshaft, high torque at low

engine speed, etc.), while weighing 200 pounds less than our 5.7-litre V-8 engine.

Another reason for Skylark's good economy is its long-legged 2.73:1 rear axle ratio.

And we shouldn't forget to mention Buick's Fuel Economy System, which is standard on Skylark S/R. The System consists of a catalytic converter, High-Energy Ignition, and GM-specification steel-belted radial tires.

Available options can also contribute to better fuel economy, and Skylark offers plenty of them. There's a Fuel Usage Light that cautions you if you're leadfooting it. And there's Cruise-Master

speed control that helps you set and hold a constant speed on trips.

If you'd like a V-8, Skylark offers a small, economical 4.3-litre V-8. Other available Skylark engines are the 5.7-litre, 2-barrel V-8 (except in California), and the 5.7-litre 4-barrel.

Finally, there's Skylark's range. With its standard 21-gallon gas tank and its impressive V-6 mileage figures, Skylark enables you to range a long way on a single fill-up.

SKYLARK LUXURY FEATURES.

You want economy. But you also want comfort. Well, in Buick Skylark you get it. Few small cars

offer all the luxury items available on Skylark. You can order power windows, electric door locks, automatic trunk release, tilt steering wheel, and stereo systems consisting of an AM radio, AM/FM radio, or AM/FM with an 8-track tape deck.

OTHER SKYLARK FEATURES.

This year, as the photo below shows, you can order a special thickly-padded Landau top. It comes with special small side windows, and is accented by a brushed aluminum band.

If you'd like to know more about Skylark, see your Buick dealer.



The 1976 Century.

Buick ownership is the knowledge that you have entered the House of Quality. You do not simply sit in a Buick; you are ensconced by it—cradled in fine fabrics, rich carpeting and shiny lacquer. And it is thus that you are conveyed: comfortably, quietly, serenely—free to relax, enjoy, survey.

For 1976, this is the kind of magic we've tried to bring to the new Buick Century—a leaner, smaller breed of Buick, that also happens to be the only American mid-sized car powered by a V-6 engine. A rather special distinction.

Century is as much as a thousand pounds lighter and two

feet shorter than full-size cars. And its personalities are as varied as the people it attracts.

For people used to big cars, Century is an economy move; a means of getting V-6 power and retaining family room at the same time.

For people used to low-priced cars, Century is a move up; an alternative to mere A-to-B transportation.

And for still others, Century is a personal car; a custom-tailored road car that rivals even the most opulent Buicks.

Whatever form of Century you prefer, it's a car that merits your closest attention.

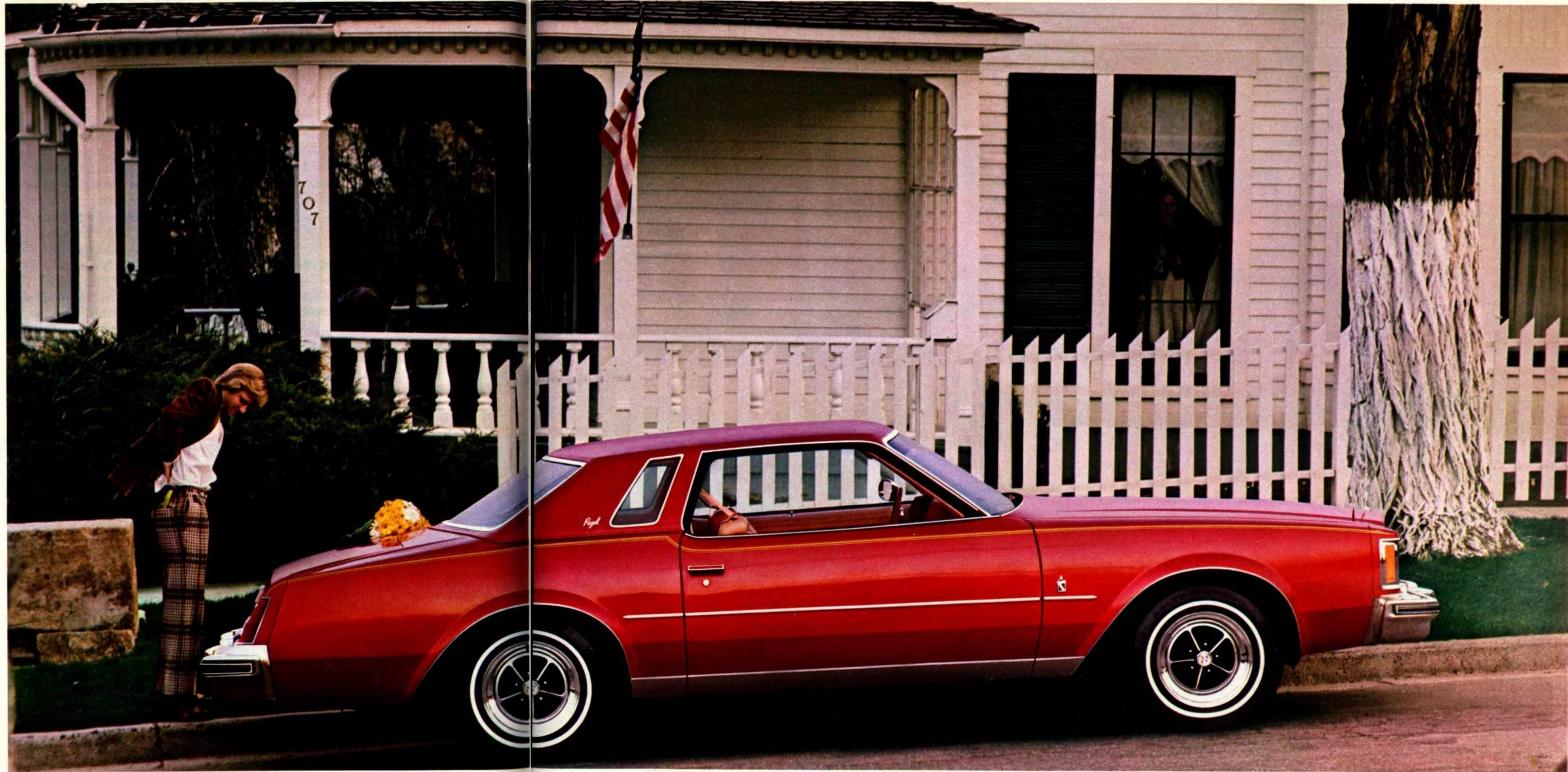

Regal. The high-line Century. Crisply-styled outside, with a formal roofline and classic vertical grille. Elegant inside, with appointments that rival full-size luxury Buicks.



The Century Custom Coupe. It wears the formal roofline of a Regal, but with a new, aerodynamic front end.

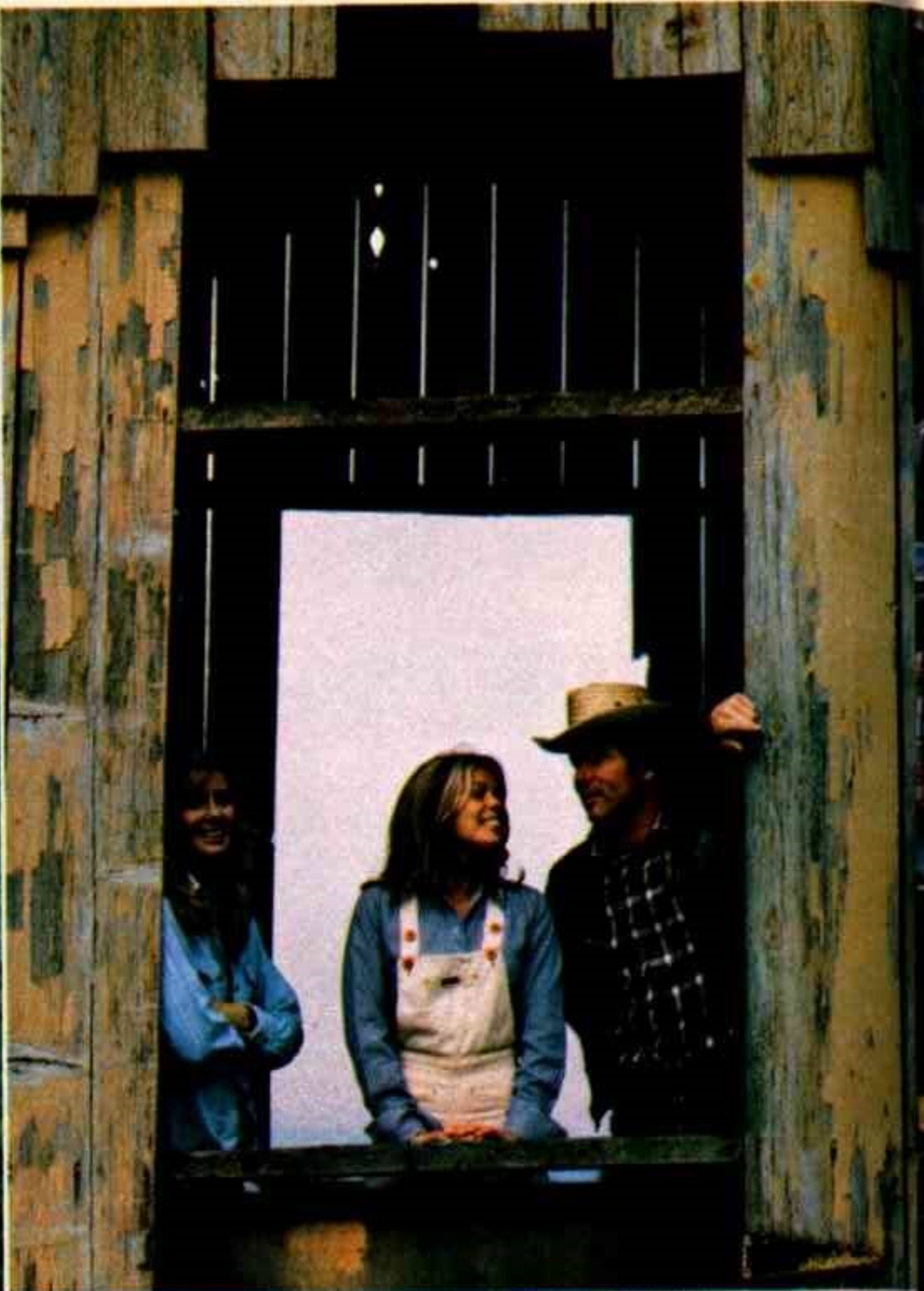

The Century Coupe. Note the canted nose and the fastback roofline.



The Regal 4-door Sedan. A blend of function and fun, utility and elegance.



The Century 4-door on top, and the Century Custom Sedan. Note the vertically-placed headlamps.



The V-6 Century Special. Specifically engineered to be low-priced, lightweight and economical.



The Century Custom Wagon. A very functional car takes on a rather handsome look.



A car this nice can make you forget all the practical reasons you have for buying it. Remember the name: Regal.

Century inside.

Buick Regal is the kind of car you buy from the inside out. Granted, its exterior look is one of elegance, but inside . . . ahh, the inside of a Regal. Glorious.

Adjust the driver's section of the available 60/40 bench seat (passengers can adjust their side to their liking). Now settle back, and relax.

The velour upholstery looks exquisite, and feels so, too. The dials, deeply set into the simulated wood-grain instrument panel, are large, logically-located, and very readable. Turn on the available air conditioning. Feel how smoothly the controls move. They are vacuum-assisted. It's nice to have a car that has but one purpose. To make you feel good.

Interior Trim Availability

Century Special Coupe	S S A A A
Century Coupe	S S A A A
Century Sedan	S S A A A
Century Custom Coupe	S S A A A A
Century Custom Sedan	S S A
Regal Coupe	S S A A A A
Regal Sedan	S S A A A
Century Custom Station Wagon	S A

S—Standard A—Available

Cloth and vinyl bench seat
 Vinyl bench seat
 Cloth and vinyl notchback seat
 Vinyl notchback seat
 Vinyl buckets
 Custom cloth and vinyl notchback seat
 Custom 60/40 cloth and vinyl notchback seat
 Cloth and vinyl S/R buckets



Regal instrument panel



Century Special/Century cloth and vinyl bench seat



Century Custom cloth and vinyl notchback seat



Century vinyl bucket seats



Century Custom custom cloth/vinyl notchback seat



Regal S/R cloth and vinyl bucket seats



Century Custom Station Wagon vinyl notchback seat

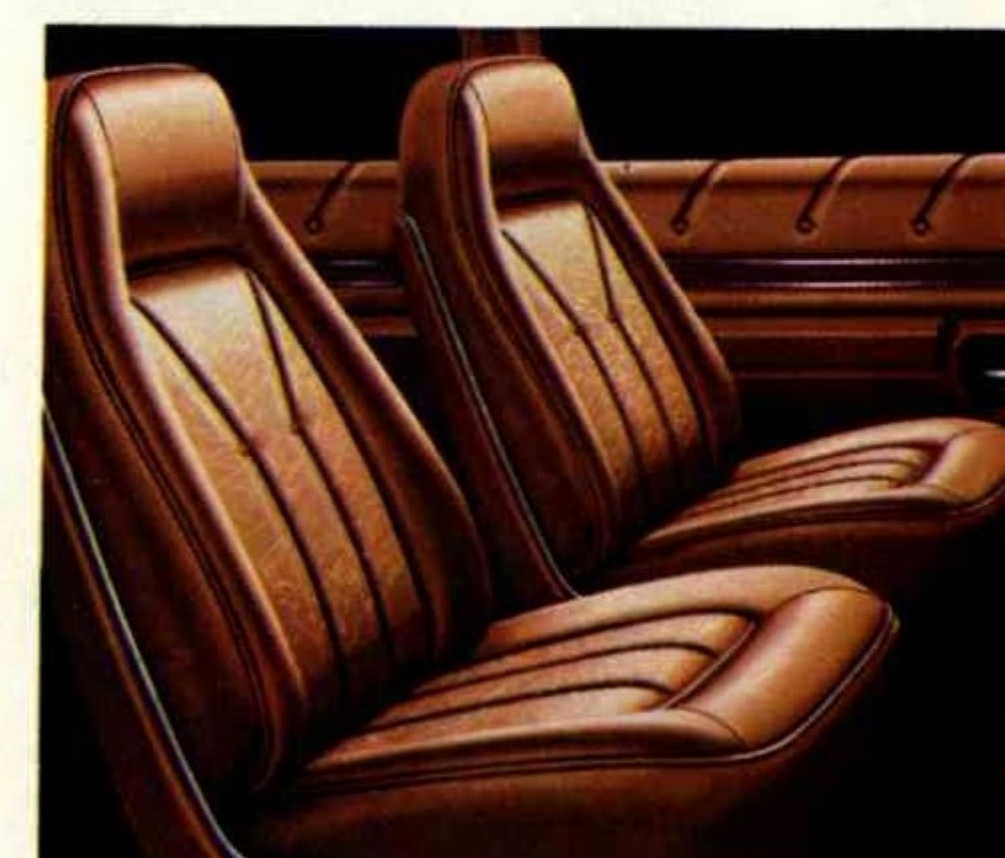

Century Custom Station Wagon vinyl bucket seats

A closer look at Century.

CENTURY SPECIAL.

More and more Americans today are looking for a car that's economically priced, economical to operate, and yet large enough to hold a family. In light of this, Buick happily introduces the 1976 Century Special. A mid-size car engineered for lighter weight, greater fuel economy and a low purchase price.

CENTURY CUSTOM WAGON.

Buick's mid-size line also includes station wagons—the Century Custom Wagon in 2- and 3-seat

models. Built on a 116-inch wheelbase, these wagons come standard with variable-ratio power steering, power front disc brakes, Turbo Hydra-matic transmission, Buick's 5.7-litre V-8 engine, and over 85 cubic feet of cargo area.

BUICK REGAL S/R.

You've already read how comfortable the inside of a Buick Regal can be. Well, in a fit of creative genius, we've designed a Regal that's even more luxurious.

The S/R package includes reclining front bucket seats upholstered in ribbed velour. Other goodies: a large center console

where the gear shift lever for the standard automatic transmission is situated. A rallye steering wheel. A headlamp dimmer incorporated into the turn signal lever. And GM-specification steel-belted radial-ply whitewall tires.

CENTURY ACCENT STRIPES.

Century offers a broad selection of available accent stripes. Ask your Buick dealer for color combinations.

CENTURY ECONOMY OPTIONS.

There are two options available that can aid you in driving your

1976 Century efficiently.

The Fuel Usage Gauge is a dial (pictured below) that tells if you're driving economically or not. When the needle points to the green area, you're driving economically. If it wanders into the red area, you're leadfooting it.

Speed Alert is simply a device on the speedometer which you set for the maximum speed you want to go. If you start to drive faster than that, a warning tone is sounded.

CENTURY ROOF TREATMENTS.

A Landau vinyl roof is available on the Century Coupes. So is an all-metal, electric sunroof.

But the big news in roofs is the Hurst Hatch Roof, available on Century Custom and Regal Coupes. The Hurst Hatch consists of two square-shaped, gray tinted glass sections. Remove the sections from the roof, store them in the trunk in a specially designed case we call the Hatch Hutch, and you've got a dynamic-looking coupe with the open-air feeling of a convertible. Sort of the thinking man's gullwing.

CENTURY SOUND SYSTEMS.

Let's face it, we're a nation of music lovers. So, it's only natural that Century offers you a complete

selection of sound systems.

There's the everyday AM radio with single or dual (front and rear) speakers. An AM/FM radio offering the same speaker configurations is also available.

Or you may specify an AM/FM stereo radio with four speakers.

If you're a tape buff, Buick also offers AM/FM stereo with an 8-track deck. And there's an AM radio with an 8-track tape deck and four speakers.

If you never thought about car stereo before, you owe it to yourself to "test listen" one this year.

We believe you'll find it's one of the nicest listening experiences you've ever had.

CENTURY LUXURY FEATURES.

In addition to stereos and tape decks, Century offers many other items that can add to your comfort and your car's personality.

To keep you cool, there are two air conditioning systems offered this year. There's Climate-Control which cools and dehumidifies the air through six, well-placed outlets. Then there's Custom-Aire air conditioning. This is a semi-automatic system. You set the temperature and blower speed you want, and Custom-Aire takes care of the rest.

Cruise-Master speed control

is another item that will increase the enjoyment level of your new Century. It allows you to maintain a constant speed (whether you're driving on hills or level ground) without having to keep your foot on the accelerator. Once you tap the brake pedal, of course, the system is deactivated and you go back to manual control.

Other luxury items you may want to specify include power windows, 6-way power seats, tilt steering wheel, electric door locks, automatic trunk release, low-speed-delay windshield wipers and a lighted vanity mirror that's recessed into the passenger's sun visor.



The 1976 Riviera.

There are two types of automobiles that stir and inspire man's love of car. The road car, with all its fun-to-drive potential; and the luxury car, with all its opulence.

Unfortunately, for most of us, the simultaneous possession of two such cars is the impossible dream. Happily, owning a Buick Riviera is not. Because at one and the same time, it is both a fine road car and a very luxurious one.

Its road car capabilities are derived from two sources: an electronically-sparked, 7.5-litre, V-8, plus a suspension system comprised of beefy shock absorbers and computer-selected coil springs at all four wheels. In addi-

tion, JR78 steel-belted radial tires grip the road, while variable-ratio power steering and power front disc brakes assist the driver. It's all standard Riviera equipment.

The other side of Riviera's personality—the luxury side—is likewise manifested in its standard equipment. The steering wheel tilts to six separate positions, the windows are raised and lowered electrically, cut-pile carpeting is underfoot, and there is a digital clock accurately monitoring the time to the vibrations of a quartz crystal.

The 1976 Riviera. A road car; a luxury car. It's two of the nicest cars you've ever wanted.

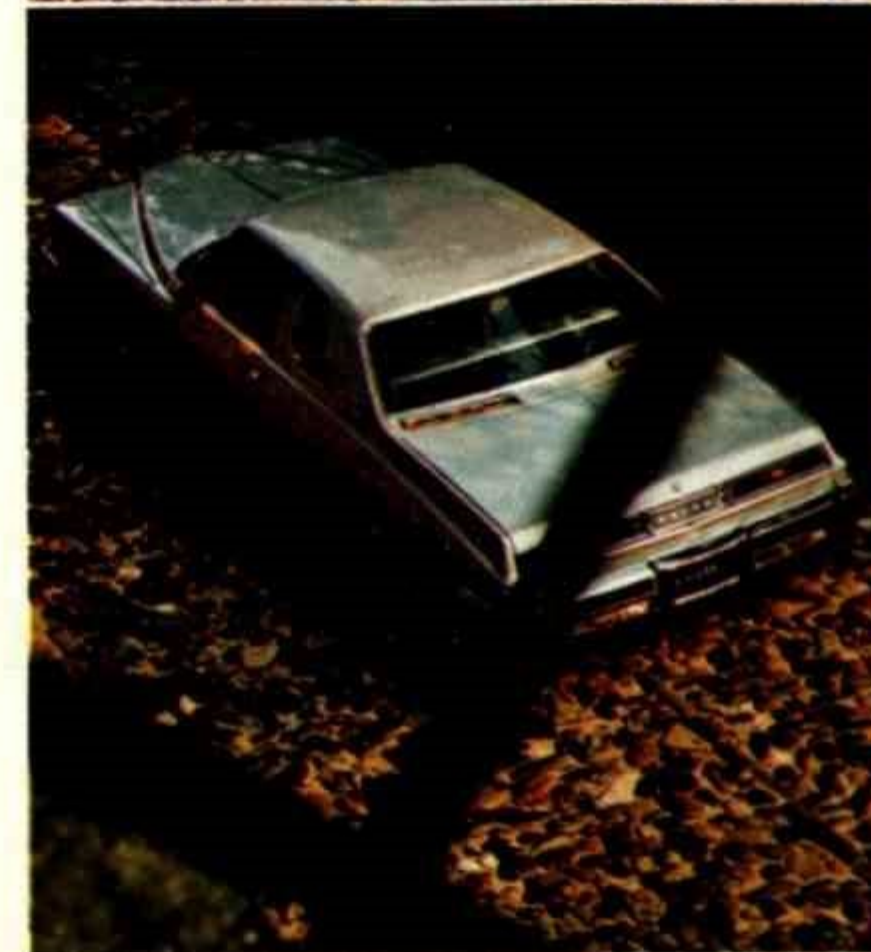
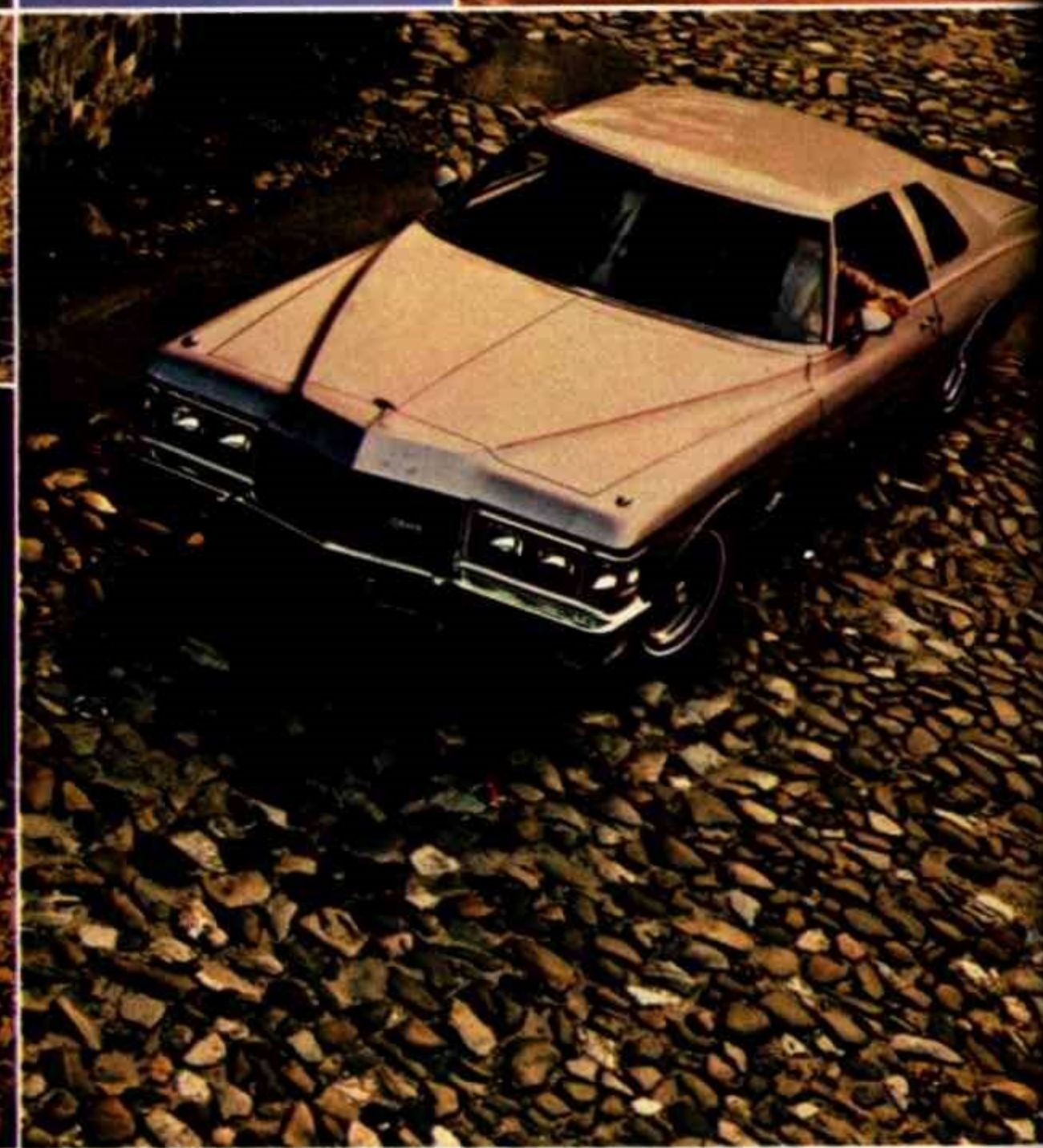
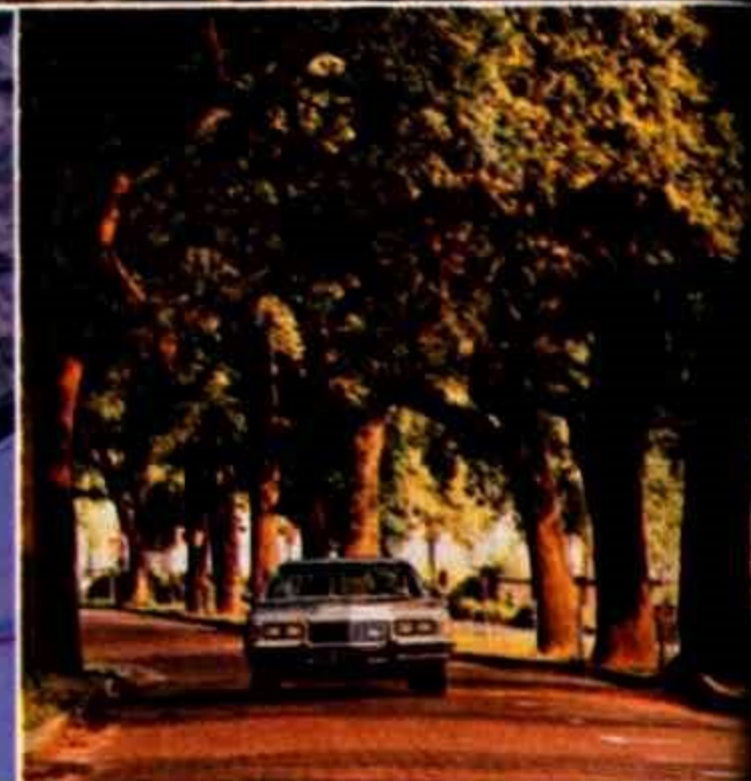

The Riviera. A road car with a multi-faceted personality. It mixes performance, elegance and romance.



The sumptuous interior of the Riviera S/R. Furniture-like upholstery and power windows are standard.

The Riviera cockpit.

Tip-toeing so as not to awaken his sleeping family, he eagerly descends the stairs, crosses the kitchen and enters the garage. There, inside, awaits his new love: his Riviera. He opens the easy-swinging door; he savors the new-car smell. He places himself behind the wheel and with a tweak of the key fires up. A push of a button adjusts the seat, another button electrically lowers the window. He switches on the 8-track stereo he ordered for some day-breaking mood music, tilts the steering wheel to just the angle he wants and—smiling all the while—off he goes. Off on the first Saturday morning doughnut run in his new “Riv.”

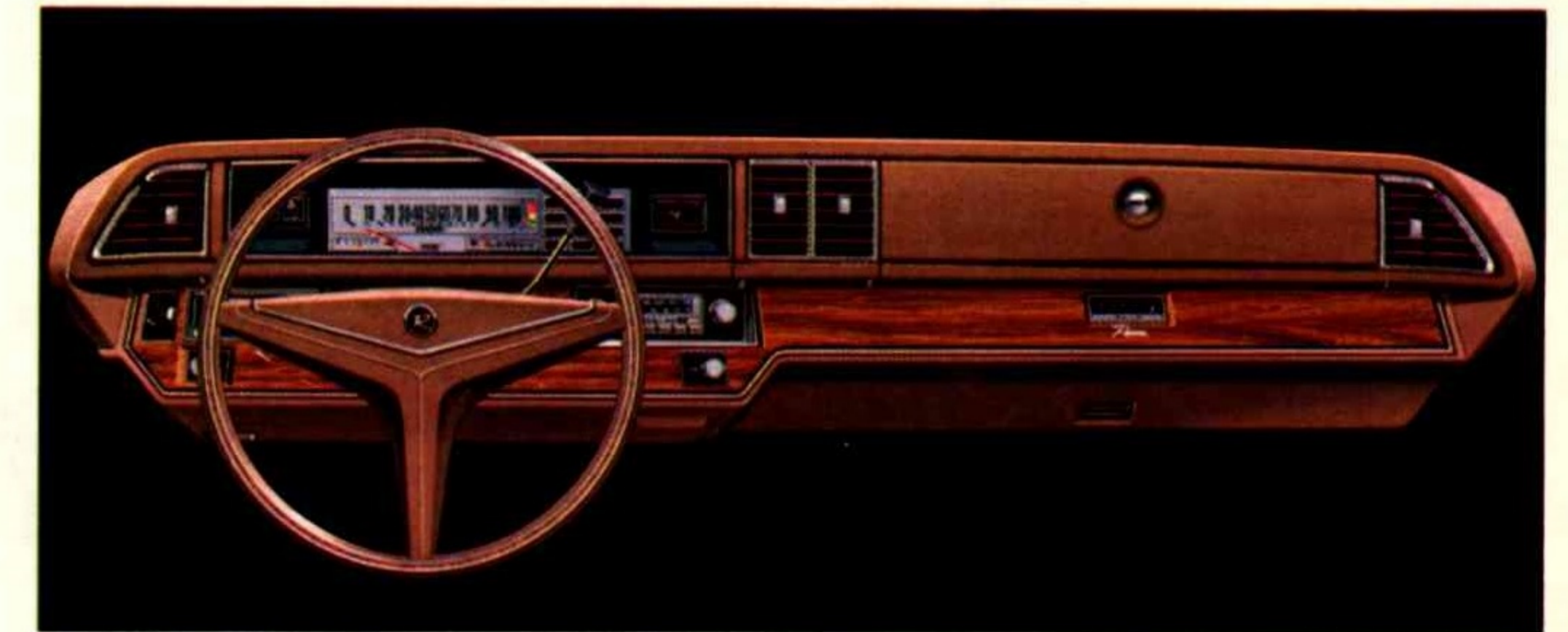

Riviera instrument panel



Riviera cloth and vinyl notchback seat



Riviera cloth and vinyl 60/40 notchback seat



Riviera vinyl 40/40 seats

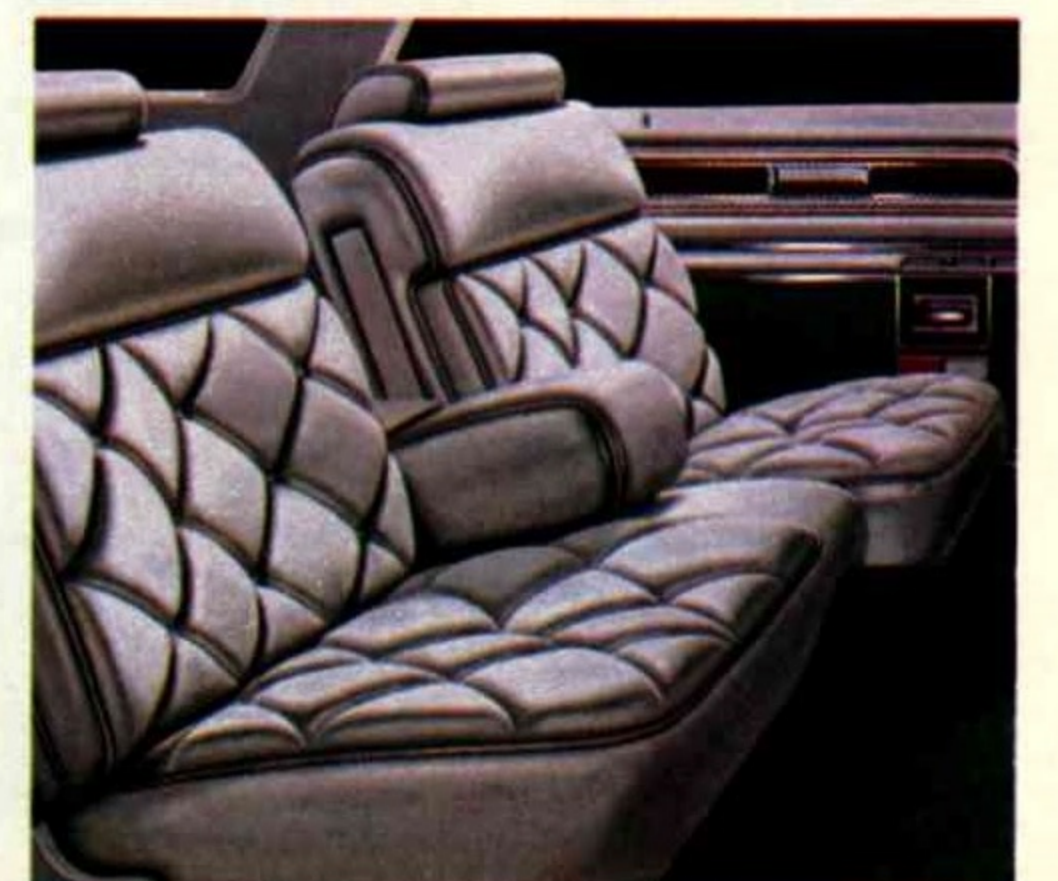

Riviera leather and vinyl 60/40 notchback seat

Interior Trim Availability

Riviera Coupe	S	A	A	A	A
Riviera S/R Coupe (available option)	S				

S—Standard A—Available

Cloth and vinyl notchback seat
 Cloth and vinyl 60/40 notchback seat
 Vinyl 60/40 notchback seat
 Vinyl 40/40 seats
 Leather and vinyl 60/40 notchback seat
 Cloth 40/40 seats

The 1976 LeSabre.

It happens all the time: the urge to escape.

So you say goodbye to the office, pick up some buddies, and head for Lake Whatchamacallit, or Mount Overlynder, or whatever. And solitude, sweet solitude.

What you need for such excursions is a container capable of transporting the entire crew.

Enter Buick LeSabre. Jackpot. Its utilitarian benefits are immediately obvious. There's ample space for six, enough trunk for all sorts of vacation gear, and improved fuel economy that makes you feel downright decent about doing the driving.

Naturally, LeSabre Custom

comes in 2- and 4-door models, each with power steering, power front disc brakes, and automatic transmission as standard equipment. Along with a 5.7-litre V-8, steel-belted radials, High-Energy Ignition, and lots of sound-deadening insulation.

Best of all, owning a Buick LeSabre can be a good lesson in economics. What with its ability to go quite a long way between recommended tune-ups and oil changes, LeSabre's one sound buy for the money.

If you've never driven a LeSabre, put this catalog down, grab the family, some friends, and go for a test-drive. All of you.

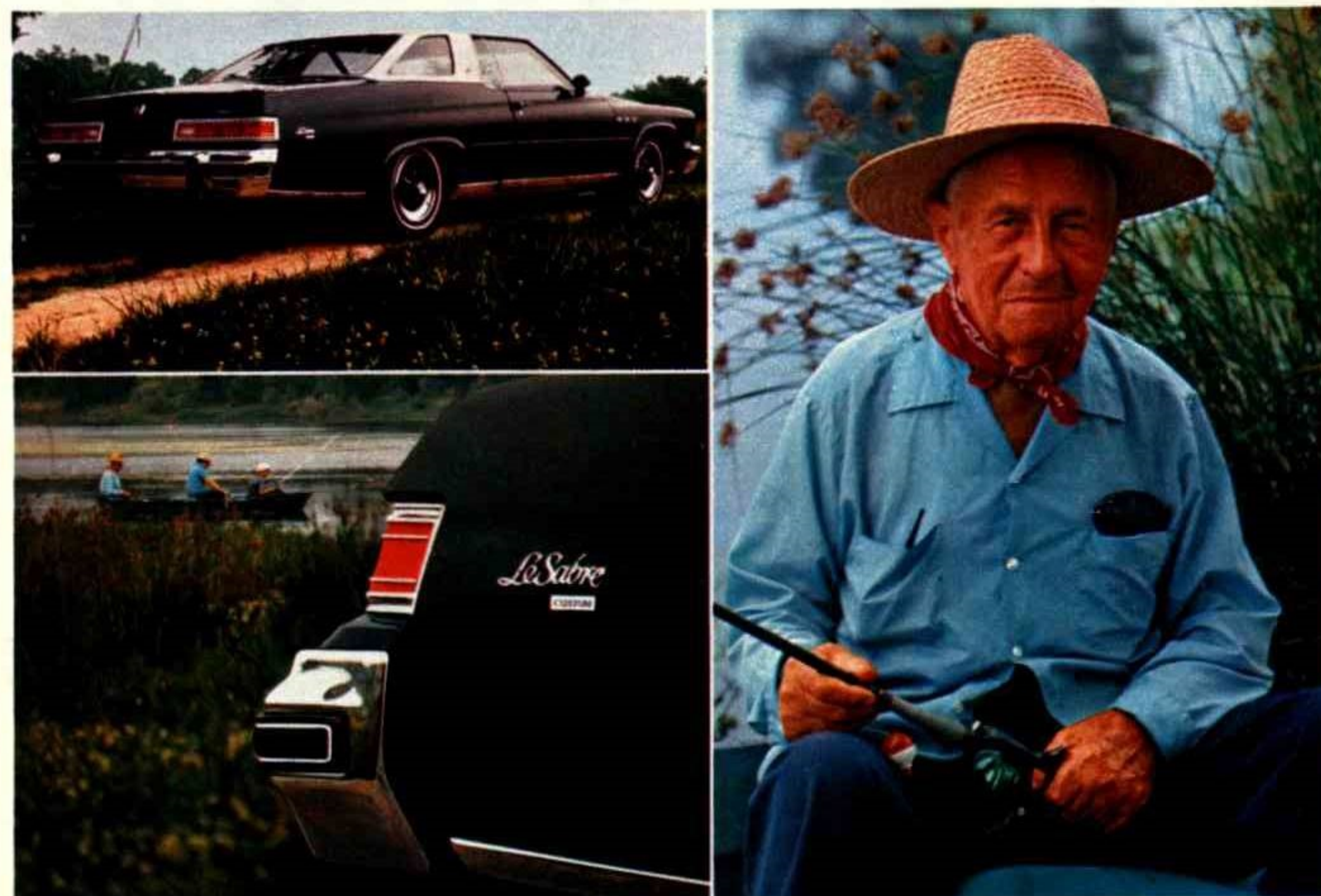

This is the LeSabre Custom Coupe. The recreational Buick. For comfortably whisking off on all manner of escapes.



The LeSabre Custom Hardtop Sedan. Power steering, power front disc brakes and automatic transmission are standard.



The LeSabre Custom Sedan. A 4-door that beautifully combines utility, luxury, and a back seat built for three.



LeSabre Custom's interior offers just one thing: luxury.

LeSabre inside.

One of Buick LeSabre's nicest qualities is its room. For family, friends, clients, kids, or whatever. But it's what we do with all this room, the way we finish it off, that makes LeSabre so very special.

At left is the LeSabre Custom with available 60/40 seats. They're of full-foam construction — so they support firmly and comfortably. And they're covered in rich, velvety, ribbed velour.

Other points of interest include: Full-flo ventilation. Cut-pile carpeting. Conveniently-placed instruments and controls. Get the idea? Inside LeSabre is a place you ought to be.



LeSabre Custom instrument panel



LeSabre Custom cloth and vinyl notchback seat

Interior Trim Availability

LeSabre Custom Coupe	S	S	A	A
LeSabre Custom Hardtop Sedan	S	S	A	A
LeSabre Custom 4-door Sedan	S	S	A	A

S—Standard A—Available

Cloth and vinyl notchback seat
 Vinyl notchback seat
 Cloth and vinyl 60/40 notchback seat
 Vinyl 60/40 notchback seat

The 1976 Electra.

The pressure was on all day. The phones ringing incessantly. Decisions. Deadlines. Conflicts. As soon as you finished one meeting, someone managed to organize another.

But as you look back now, it seems curiously worth it.

Because you're reviewing the day from the driver's seat of your new Buick Electra Limited.

The available Automatic Climate Control dehumidifies and quickly brings the temperature to 70 degrees. Just where you want it. Your back muscles welcome Electra's full-foam seating. You adjust the seat (2-way power seats are standard), flip the center arm-

rest down, assume a comfortable driving position, touch the key, and away you go.

As you proceed, Electra's long wheelbase and computer-selected coil springs help neutralize the effects of tar strips and bumps in the road. Turbo Hydra-matic, power steering, and power front disc brakes make the driving seem downright effortless, as strains from the AM/FM stereo you ordered put busy thoughts to rest. Heck, the day was almost fun.

And before you know it—you're home. Thanks a lot, Buick.

Hello, home. Hello, good old ever-lovin' home.

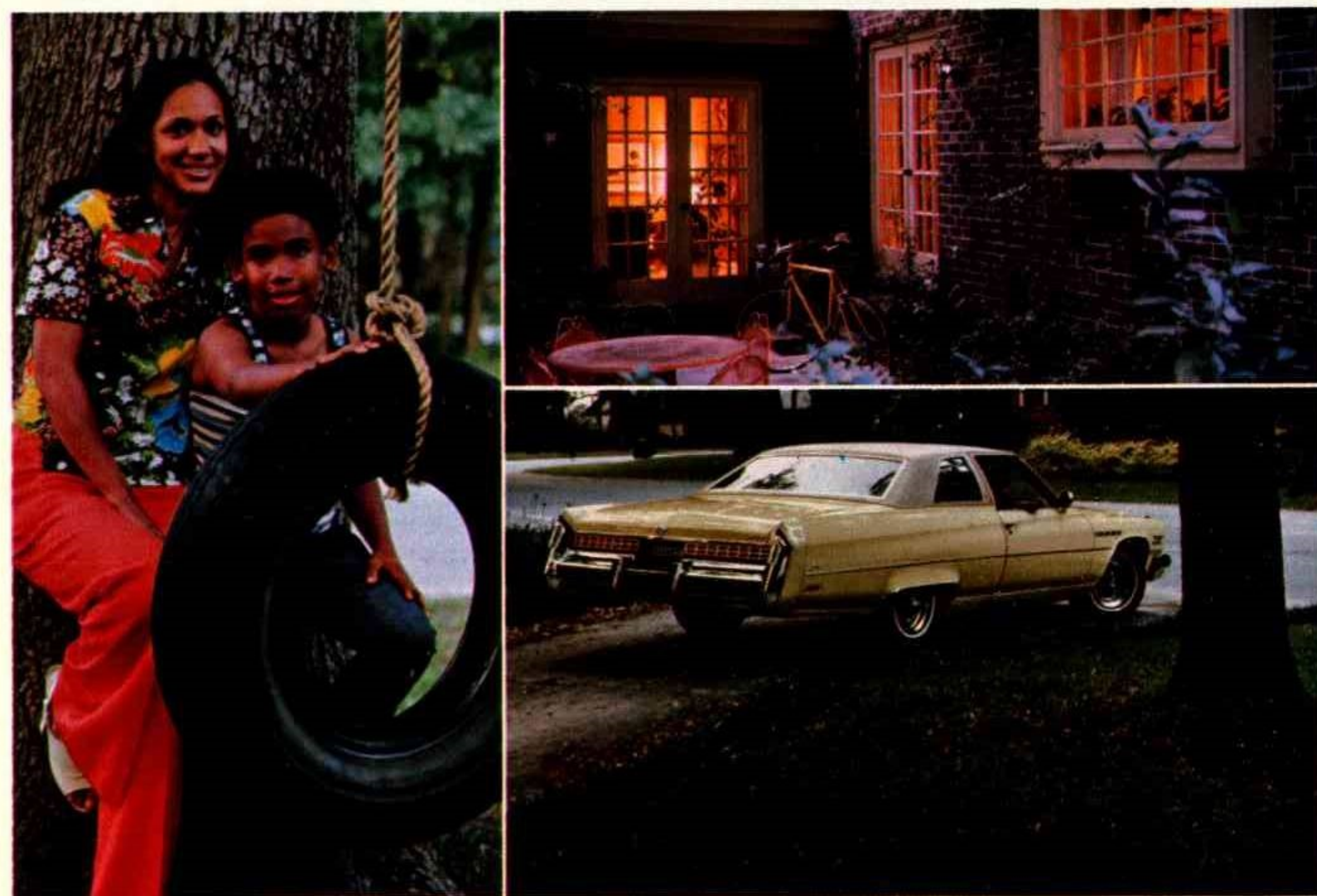

The Electra Limited Coupe. The kind of car you've worked hard to earn. The kind of car you deserve.



Electra Park Avenue. The ultimate Buick.

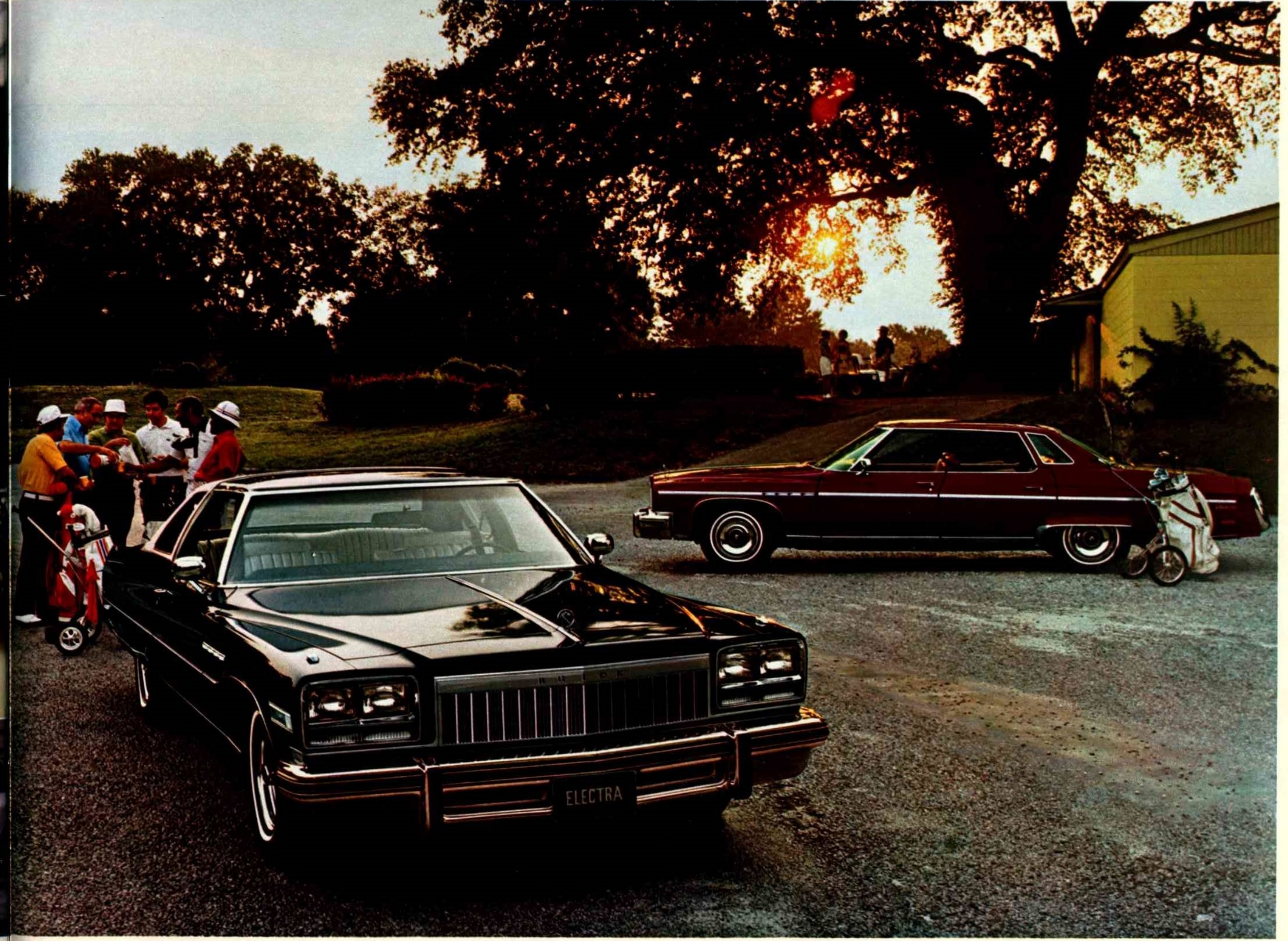

The Electra 225 Landau Coupe, foreground, and the Electra 225 Hardtop Sedan. Luxury cars of a most satisfying nature.



The inside of an Electra offers something that's very welcome in today's world: good old peace and quiet.

Electra inside.

Few cars are so thoroughly-equipped for your comfort and convenience as Electra. Power windows are standard. Also power steering, power front disc brakes and automatic transmission. And when you want the time, glancing at your Electra's clock, rather than your wristwatch, may be a more accurate check. An electronic digital timepiece, whose vibrating quartz crystal separates each second into nearly 2 million increments, is standard equipment.



Electra Limited instrument panel



Electra 225 cloth and vinyl bench seat

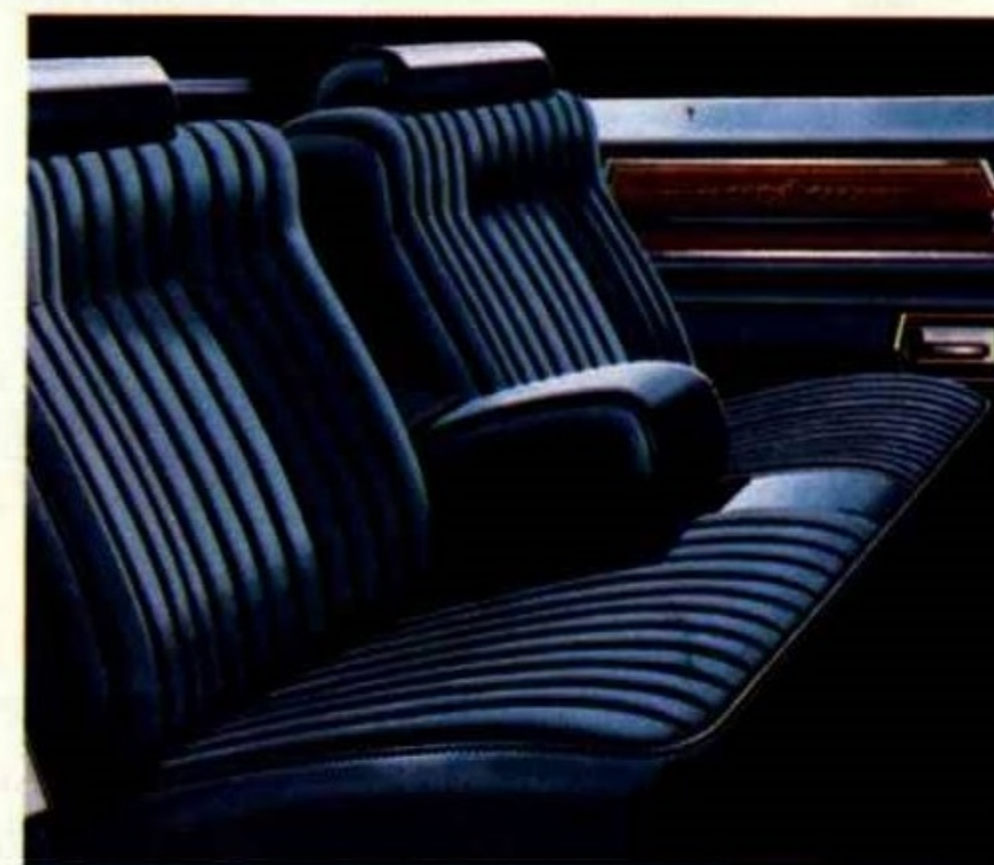

Electra 225 cloth and vinyl notchback seat



Electra 225 cloth and vinyl 60/40 notchback seat



Electra leather and vinyl 60/40 notchback seat



Park Avenue cloth and vinyl 40/40 seats



Park Avenue cloth and vinyl 60/40 notchback seat

Interior Trim Availability

Electra 225 Coupe	S S A A
Electra 225 Sedan	S S S A A
Electra Limited Coupe	S A
Electra Limited Sedan	S A
Electra Park Avenue Sedan (available option)	S S

S—Standard A—Available

Cloth and vinyl bench seat
 Cloth and vinyl notchback seat
 Vinyl notchback seat
 Cloth and vinyl 60/40 notchback seat
 Vinyl 60/40 notchback seat
 Custom cloth and vinyl 60/40 notchback seat
 Leather and vinyl 60/40 notchback seat
 Cloth and vinyl 40/40 seats
 Cloth and vinyl 60/40 notchback seat

The 1976 Estate Wagon.

For some people, a station wagon is the ultimate "freedom machine"—freer even than some sleek, wind-piercing sports car. The reason is, a station wagon is ambidextrous—on one hand it works hard, on the other, it plays hard. It's as much at home hauling a load of kids, water skis, and other paraphernalia to a weekend resort as it is hauling a load of lumber for a weekend project.

Which brings us to the Estate Wagon. A car of remarkable capabilities because it's both a wagon and a Buick. Which means a lot.

Because it's a wagon, it offers both utility and fun. Because it's a Buick, it offers a comfortable

seating area (the available notch-back seats are just like LeSabre's), plenty of luxury items (power steering, power front disc brakes and automatic transmission are standard) and a smooth Buick ride (thanks to a specially-engineered suspension with computer-selected coil springs in front and leaf springs in back).

Also, as you can see from the photo below, the Estate Wagon has an ingenious tailgate. The lower section glides away under the floor, and the window recedes up into the roof.

In all, it's a free-spirited Buick with lots of room for free-spirited things.

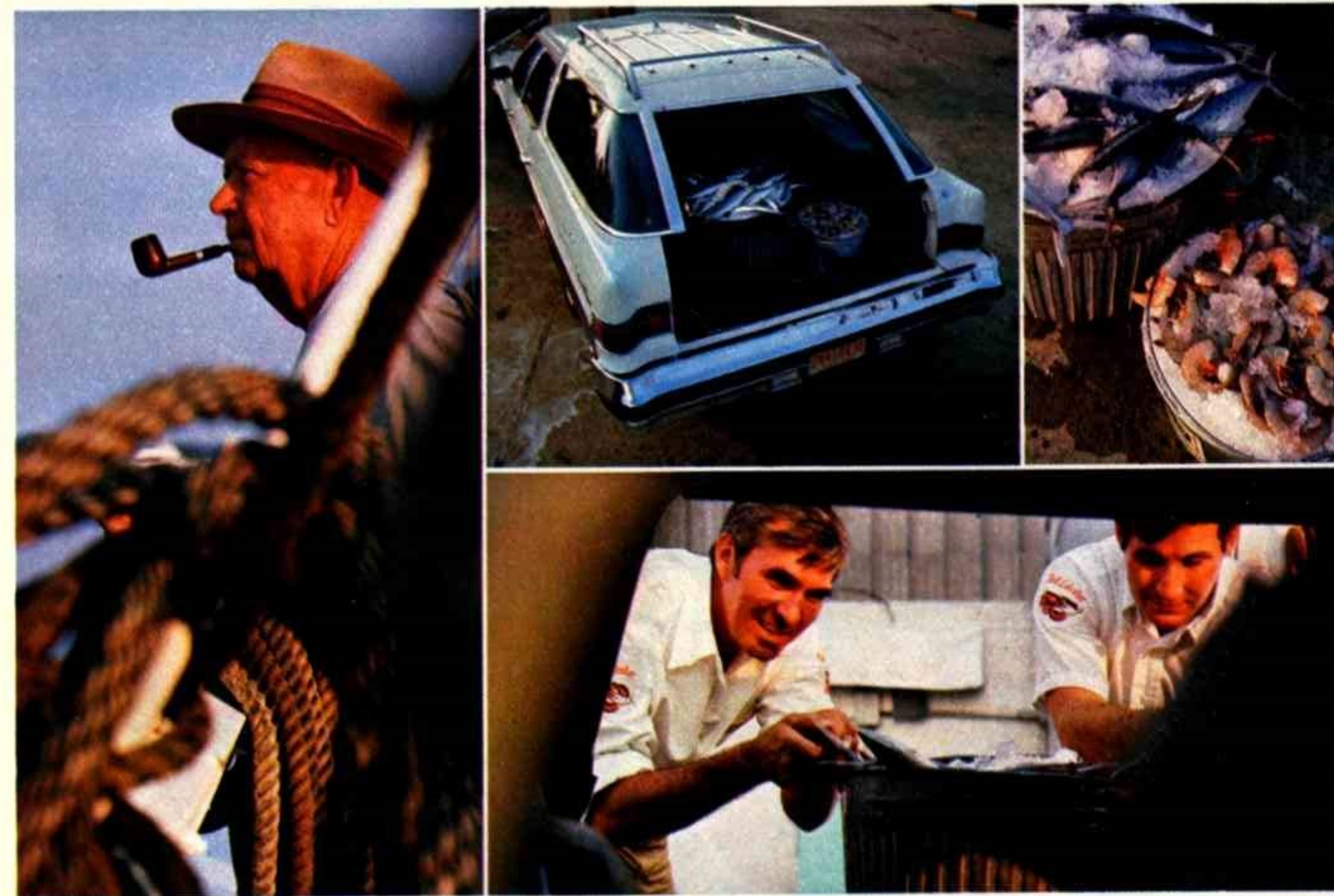

Estate Wagon. It's more than just a full-size wagon, it's a full-size Buick.

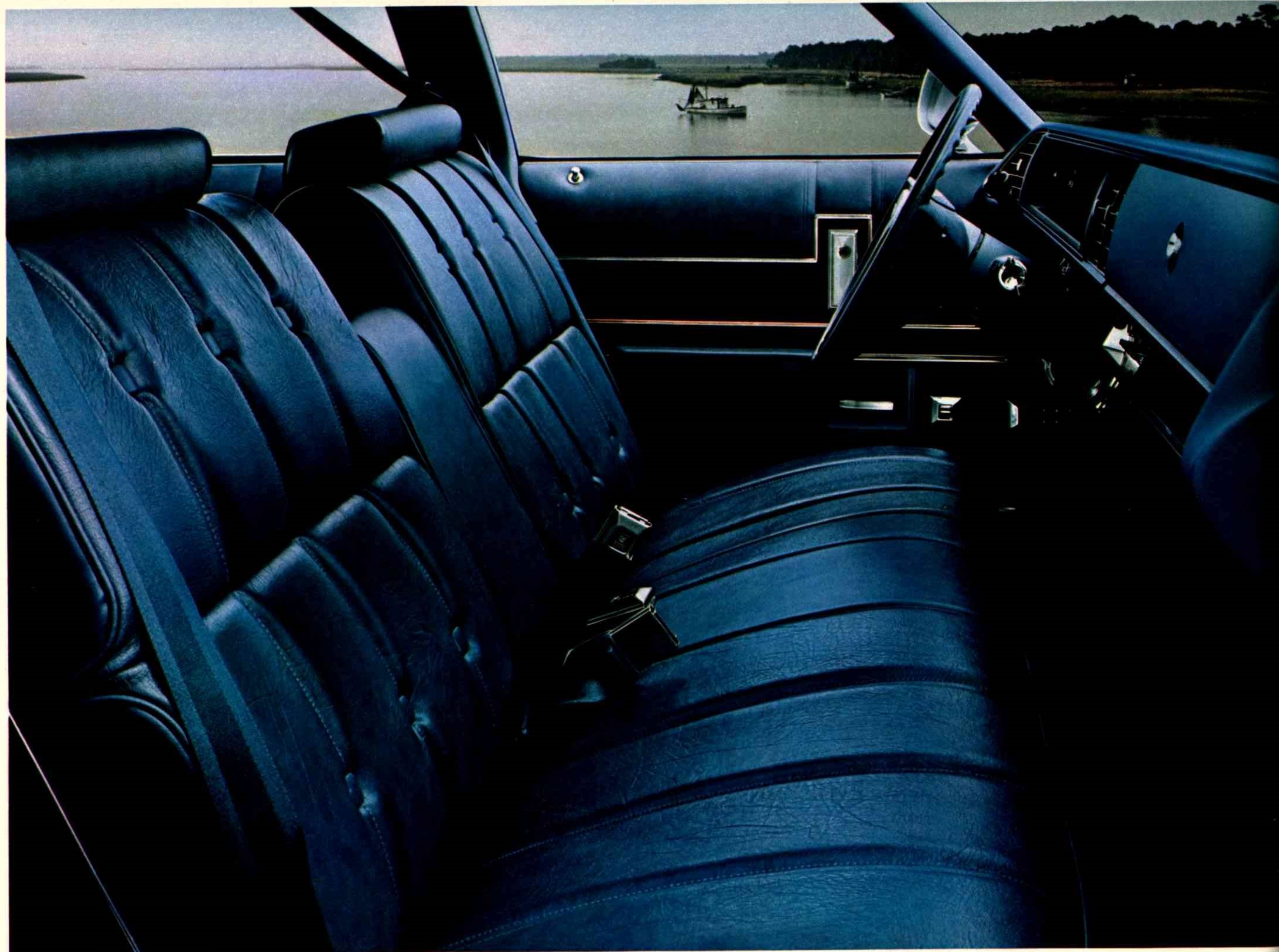

Where are you?—in a luxury car?—a limousine? Surprise, you're in a Buick Estate Wagon.

Estate Wagon inside.

One of the most important parts of a station wagon is its interior. Which is why Buick has paid so much attention to the inside of the Estate Wagon. Coupled with the huge, 106-cubic-foot cargo area is a most comfortable driving area—which shares many features with Buick LeSabre. The instrumentation, the simulated wood-grained instrument panel, the steering wheel, carpeting, and the available notchback seat (like the one on the left) are all identical to LeSabre's. So, don't think of your Estate Wagon as merely a station wagon—consider it a full-size Buick with a 106-cubic-foot trunk.



Estate Wagon instrument panel



Estate Wagon vinyl bench seat



Estate Wagon cloth and vinyl 60/40 notchback seat

Interior Trim Availability

2-seat Estate Wagon	S	A	A	A	A
3-seat Estate Wagon	S	A	A	A	A

S—Standard A—Available

Vinyl bench seat
 Cloth and vinyl notchback seat
 Vinyl notchback seat
 Cloth and vinyl 60/40 notchback seat
 Vinyl 60/40 notchback seat

A closer look at Riviera, LeSabre, Electra and Estate Wagon.

BUICK LUXURY FEATURES.

A Buick is built to offer outstanding comfort as standard equipment. But there are some available items you may wish to order to fit your new Buick more specifically to your wants and needs. A few are discussed here.

Buick offers three air conditioning systems on its full-size cars. Basic Climate-Control air conditioning is available on Riviera, Electra, LeSabre, and Estate Wagon. Custom-Aire air conditioning (a semi-automatic system) is available on LeSabre and Estate Wagon. And Automatic

Climate-Control is available on Riviera and Electra. It's a fully-automatic system incorporating both the heater and air conditioner.

A full complement of sound systems is available on Riviera, Electra, LeSabre and Estate Wagon, too. Including AM/FM stereo, AM/FM stereo with 8-track tape deck, and AM radio with stereo 8-track tape deck. After all, what's the good life without music?

As you can guess, there's a flock of luxury items we could further go into—like automatic door locks, 6-way power seats, power windows, a tilt and telescope steering wheel, an electric trunk release—but space limits.

And your Buick dealer will be happy to show all of them to you in person.

ECONOMY FEATURES.

Fuel economy is a very important consideration for anyone buying a big car this year. And we've done a lot of redesigning to see that your new Buick delivers it.

In addition to redesigning our quadrajet carburetor, we've increased the spark advance for the 5.7-litre and 7.5-litre V-8 engines this year. This means it takes less fuel to get the same amount of power from these engines.

We've given the 5.7-litre V-8 a new camshaft which gives the engine more power at low engine speeds. So you don't have to put your foot into it to get the same level of acceleration. The result: better fuel economy.

Also, Riviera, LeSabre and Electra have a lower, 2.56:1 rear axle ratio. This lets the 7.5-litre engine turn over fewer times per mile, and helps gas mileage.

And finally, there are many features available on the full-size Buicks that can help you squeeze more miles out of each tankful. Things like a fuel usage gauge, speed alert and Cruise-Master speed control.

THE ELECTRA PARK AVENUE.

The Park Avenue is an ultra-luxurious edition of the Electra Limited Hardtop Sedan.

Simply put, it's Electra, only more so. And you just can't do any better than that.

Outside, a formal "halo" vinyl roof sets the theme. Inside, thick, cut-pile carpeting and velour upholstery abound. The seats, the executive center console, even the ceiling, are covered with exquisite soft velour. Front seating comes in two arrangements. You may choose 40/40 seats (that's two huge bucket-type seats, separated by

a console). Or a 60/40 front seat (40% for the driver, 60% for the passengers). Both sides of this seat adjust independently, and the center console is eliminated.

ASTROROOF.

No mere sunroof, this. It's actually three roofs in one.

One, at the prod of a button, you can electrically retract the glass section and have the sky overhead. Or, two, with another touch of the button, you can slide the glass back to its original position and have a glass-topped driving compartment. Or, three, you can draw the sunshade and

you have a well-tailored, tight-fitting headliner overhead.

Both the Astrorooft and a conventional sliding metal sunroof are available on Riviera and Electra Coupes.

OTHER EXTERIOR TREATMENTS.

Electra Coupes offer two available Landau vinyl tops this year. The first is the traditional vinyl Landau top shown on page 41. The second gives a completely different look. (See picture below.) The standard Electra opera windows are smaller, and the back portion of the roof is then covered with thickly-padded vinyl with French

seams. A stylish touch for Electra.

Go on, you say? Fine with us. Riviera offers a new 2-tone exterior color scheme. The second color is actually a vinyl applique bonded to the sides of the car. There are four special color schemes available.

Another Buick with a special vinyl applique treatment is the Estate Wagon. The wood-grain scheme, shown on page 44, is available with any exterior color.

And on Riviera, LeSabre and Electra, you may order a variety of exterior accent stripes.

Ask your dealer about these and other ways you can personalize the exterior of your new Buick.



The 1976 Buick model line-up.

Skyhawk. The smallest Buick in 60 years. And the most free-spirited.



Skyhawk Hatchback Coupe



Skyhawk 'S' Hatchback Coupe

Skylark. The only V-6-powered compact made in America comes from Buick.



Skylark Coupe (S/R Model available)

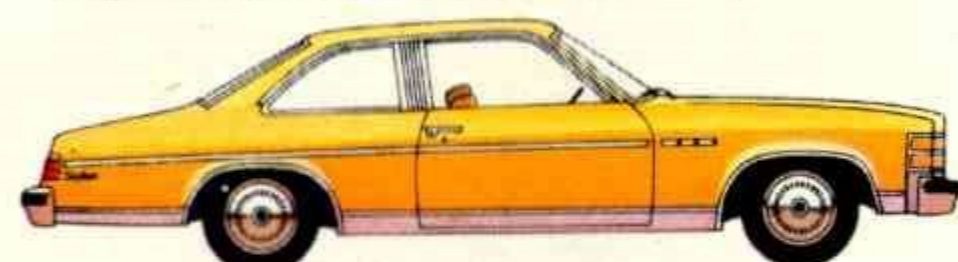

Skylark Hatchback Coupe (S/R Model available)



Skylark Sedan (S/R Model available)

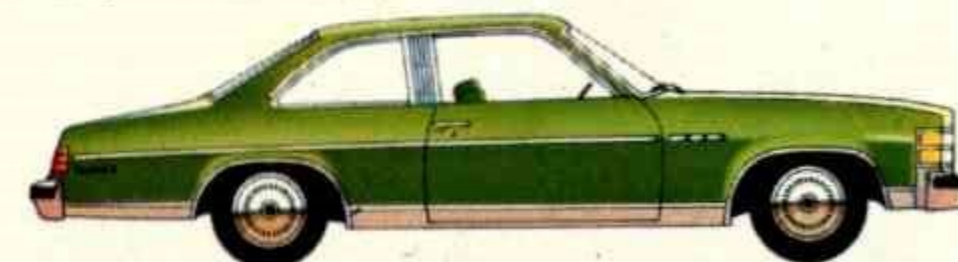

Skylark 'S' Coupe

Century. The only American mid-size car powered by a V-6 also comes from Buick.



Regal Hardtop Coupe



Regal Hardtop Sedan



Century Custom Hardtop Coupe



Century Custom Hardtop Sedan

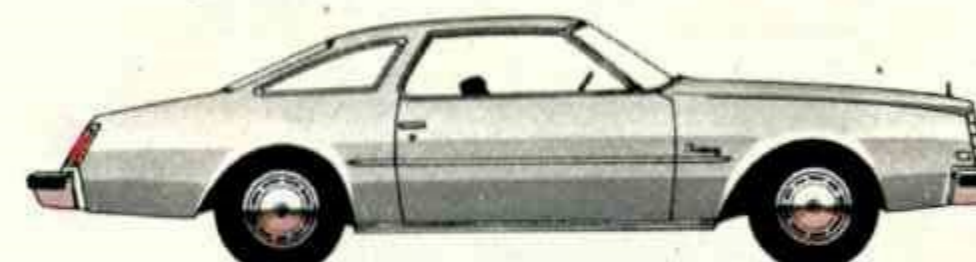

Century Hardtop Coupe



Century Hardtop Sedan



Century Special Hardtop Coupe

Century Custom Wagon. A mid-size Buick with station wagon capaciousness and versatility.



Century Custom Station Wagon (2- or 3-seat)

Riviera. It's two of the nicest cars you can own: a personal car, and a luxury car.



Riviera Hardtop Coupe

LeSabre. Genuine six-passenger room makes it ideal for businessmen, families.



LeSabre Custom Hardtop Coupe



LeSabre Custom Hardtop Sedan



LeSabre Custom 4-door Sedan

Electra. A luxury car of the highest order: rich appointments and supreme comfort underway.



Electra Limited Hardtop Coupe



Electra Limited Hardtop Sedan



Electra 225 Hardtop Coupe



Electra 225 Hardtop Sedan

Estate Wagon. Offers the utility of a wagon and the creature comforts of a Buick.



Estate Wagon (2- or 3-seat)

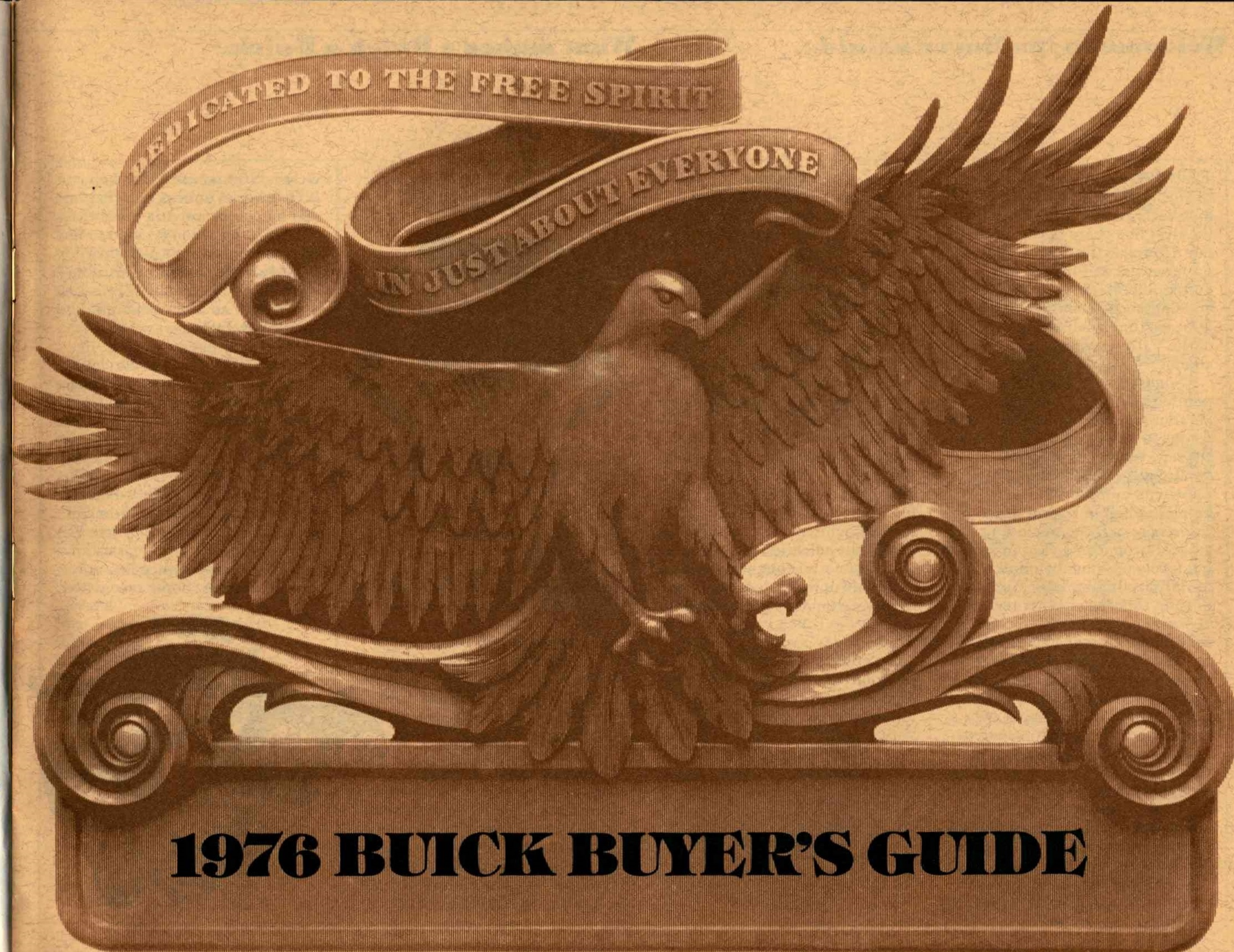

The 1970's may well go down as the decade of the Great Automotive Transformation. During the first five years of this decade, our driving attitudes, buying preferences, and indeed, the automobile itself, have undergone immense changes. And it appears that the final five years of the '70's will bring continued change.

Some general trends can be pointed to. We are buying smaller and lighter cars. And just as our tastes are changing, so is the new emerging breed of small car. Inside, a design discipline known as human engineering is being applied in liberal doses. Interior appointments and creature comforts are approaching levels previously found only in full-size luxury cars. Yet, despite this rage for luxury and convenience, the need to conserve fuel is a reality. Therefore, we Americans are demanding more efficient, more economical engines to power our cars. The net effect of all this is that we are buying, and will continue to buy, automobiles that are something of a paradox: rich in luxury, abundant in comfort, and economical to operate. Buick is answering these new trends with new products. Skyhawk, Skylark and Century, the new Buicks of the '70's, are small, lightweight, and economical. They are powered

by Buick's V-6, the only V-6 engine designed and built in America, and which, like the cars themselves, is compact and very economical. And of course, Buicks have long been famous for their comfortable, functional interiors and mechanical reliability—qualities that are increasingly important at a time when we Americans are keeping our cars longer.

This Buyer's Guide will give you an in-depth look at the 1976 Buicks. You'll learn about the design, engineering, and testing that makes a Buick a Buick. There's a comparison of the different sizes and styles of Buick models, which will hopefully aid you in the selection of your new car. There's a thoughtful look at available options, too. And finally, two pages are devoted to each of the Buick car lines. Those pages contain a listing of some standard and available equipment, as well as an Ordering Guide, which gives you a handy way to personally select your new Buick.

**GENTLEMEN,
START YOUR ENGINES.
(LADIES INVITED).**

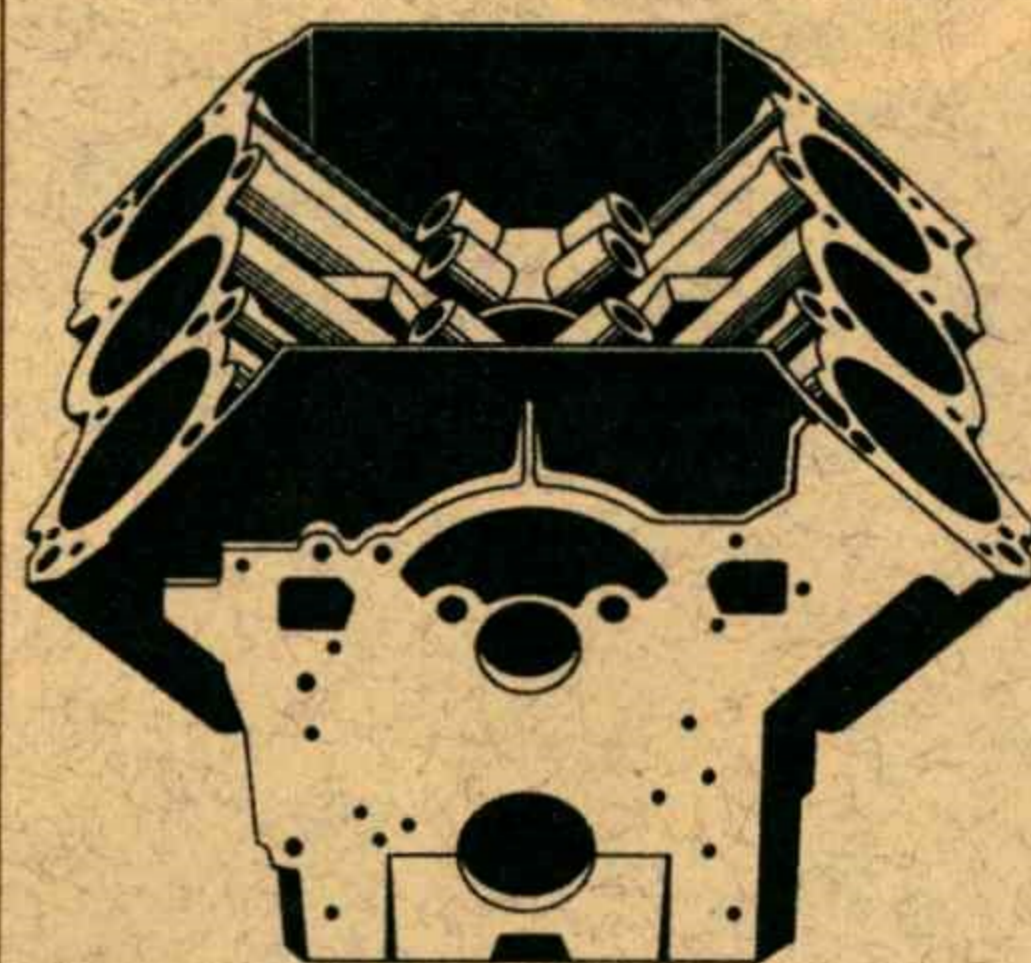

Our engine lineup this year is actually quite simple. We offer five different powerplants, each with its own niche. And each with a heritage of design innovation and proven performance.

Perhaps the biggest engine news is the Buick V-6.

There's no mistaking Buick's V-6 with other sixes. For one, the cylinders are banked three to a side. Which makes for a short, light, compact engine.

You'll also be glad to know that our V-6 shares many design efficiencies with its Buick V-8 brethren. Fact is, pistons, rings, wrist pins, rod bearings, timing gear and more, are identical to those used on bigger, 5.7-litre V-8. The end product is a 3.8 litre, 2-barrel V-6 that

weighs 200 pounds less, has 25% fewer cylinders and pistons, and has fewer moving parts than our V-8. And when it came to fuel economy, last year's V-6 gave slightly better overall EPA mileage figures than our 1975 in-line 6, which is no longer offered. The Buick V-6, by the way, is the only V-6 designed and built in America. (Standard in Skyhawk, Skylark, Century Special, Century, Century Custom and Regal Coupe)

As justifiably proud as we are of our V-6, it isn't the only underhood star in our lineup. That is to say, we also field a 4.3-litre V-8, a 5.7-litre V-8, in both 2-barrel and 4-barrel versions, (2-barrel N.A. in Calif.) and a 7.5-litre V-8.

Refining our V-8 engines for improved performance is a never-ending process. Some recent

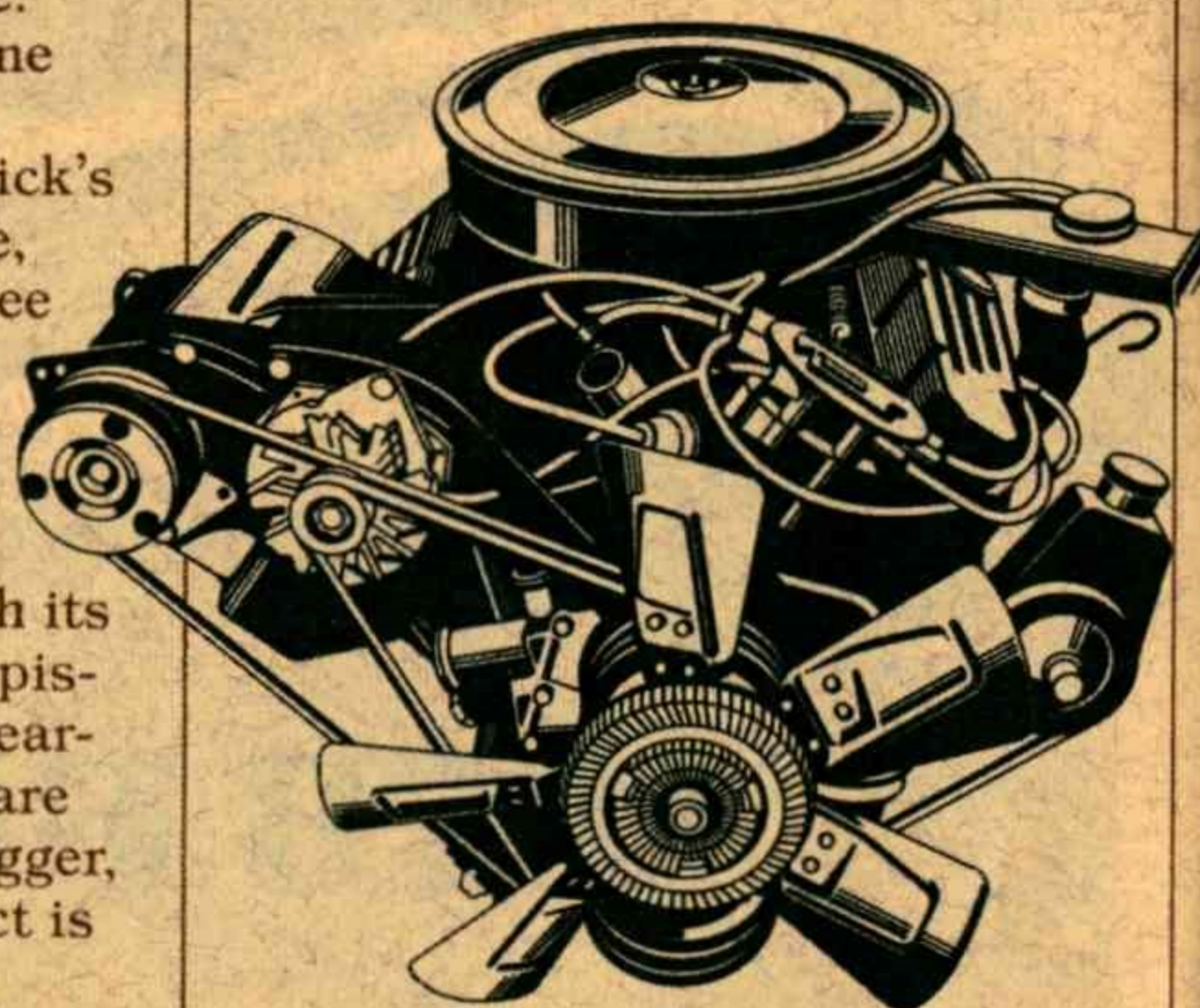

accomplishments worthy of note include our Quick Engine Warm-up System and fast acting choke, to help get you on your way quickly, with less fuel wasted. Furthermore, all Buick engines use steel rocker arms and nickel-plated exhaust valves—both designed for long engine life.

But our best V-8 news for 1976 is fuel economy. By increasing spark advance, changing the 5.7-litre engine camshaft, lowering axle ratios on our full-size cars, and improving our quadrajet carburetor design, we've improved fuel economy on an overall basis.

Then there's engine testing: constant and thorough, to keep Buick engines on a par with design potential. Before a Buick engine is ever placed in a chassis, it must pass four tests. Test number one is the Air Motoring Test. The engine runs for the first time using highly compressed air as energy. The balance is checked and timing is set and rechecked to a high degree of accuracy. Test number two is a Sonic Test. All openings on the engine block are sealed and compressed air is forced into the inner chambers of the engine. All this takes place in a sound-proof room where inspectors, using microphones and earphones, listen for any air leaks in the oil lube system. Test

number three, the Water Jacket Leak Test, is also performed using pressurized air. This is a very accurate test which detects both leaks in the engine's water passages, and any internal leaks between the water passages and the oil sump system. Test number four is called the Hot Test. The engine is coupled to a machine and is run on natural gas for six minutes. During that time, the power output of the engine—both in total and cylinder-by-cylinder—is tested.

And so, while the engine under the hood of your 1976 Buick may be shiny new on the surface, underneath, it's a tried and tested veteran.

**BUICK'S FUEL ECONOMY SYSTEM.
WE HAVE GOOD REASON
FOR CALLING IT THAT.**

It works. Our three-pronged approach to fuel economy was no easy achievement. But then nothing worthwhile ever comes easy.

First off, there's a catalytic converter. Without going into endless detail, it does a simple job: cleans up exhaust emissions after they leave the engine which allows us to retune the engine itself for good mileage. Step two, High-Energy Ignition, sends 35% more voltage to the spark plugs and eliminates the need



for points and ignition condenser. So the engine stays in tune longer. And as a bonus, the recommended spark plug change interval has been extended up to

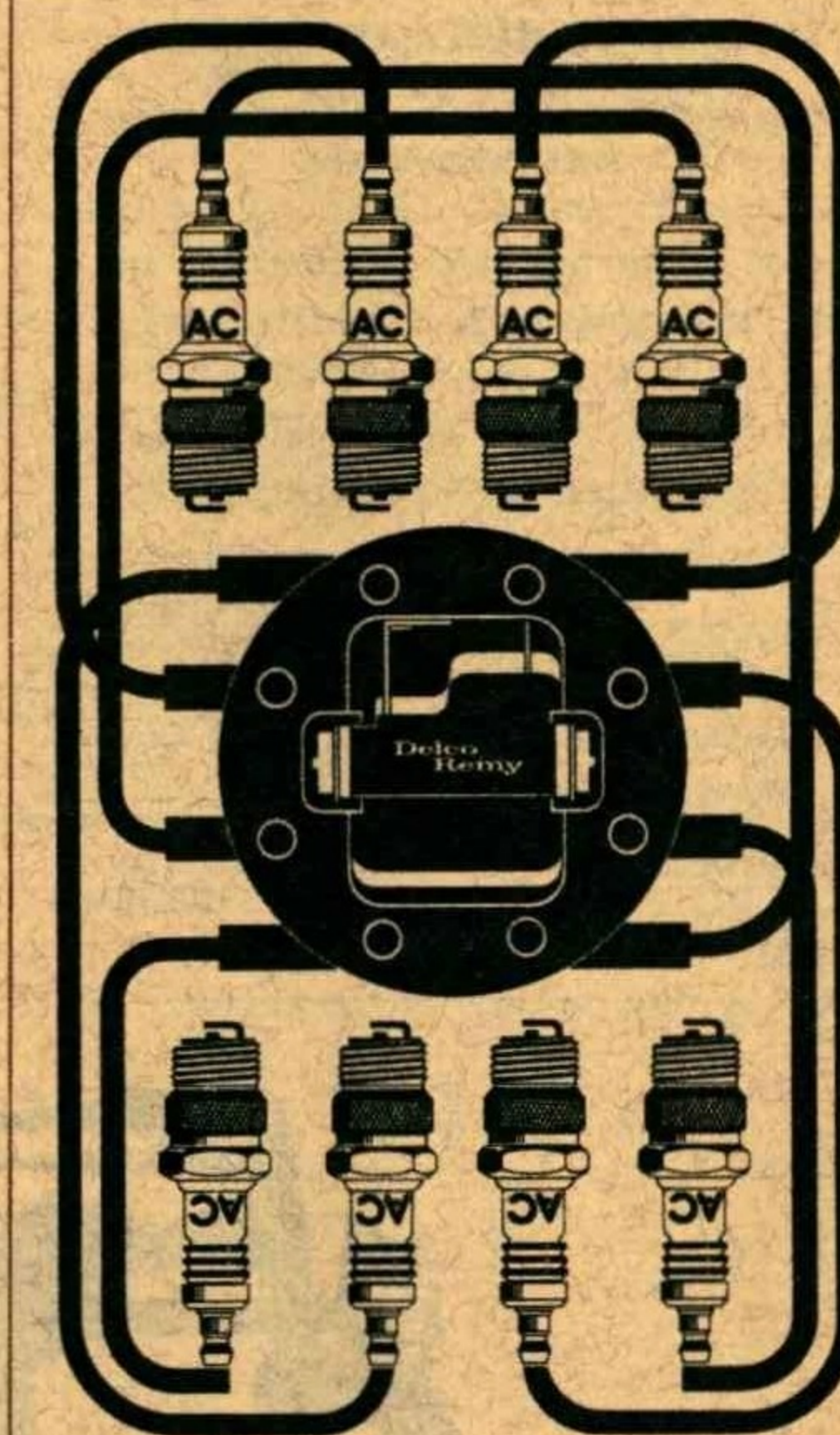

22,500 miles. Step three, radial tires, isn't exactly new. You know radials have a stiff resistance to cuts and abrasions. And low internal friction, which contributes to long tread life. But the key to better fuel economy with these tires is their low rolling resistance. That is, it takes less energy to make radials roll the same distance as conventional bias-ply tires.

And that's Buick's Fuel Economy System.

**WHEN YOU BUY A 1976 BUICK,
YOU'RE BUYING A CAR
THAT REQUIRES LESS ROUTINE
MAINTENANCE.**

How often service is needed is an important consideration when buying a new car. And we're proud to say that the 1976 Buicks require much less routine main-

tenance than cars of only a few years ago. This is due to many factors: Buick's High-Energy Ignition System, the use of no-lead fuel, and more effective filters. The comparison chart below illustrates the fewer number of times your new Buick will require routine maintenance.

Item	1976 Maintenance Schedule	Pre-1975 Maintenance Schedule
Engine oil change	Every 6 mos. or 7,500 mi.	Every 4 mos. or 6,000 mi.
Oil filter change	After 1st 7,500 mi., then every 15,000 mi.	After 1st 6,000 mi., then every 12,000 mi.
Spark plug change	Every 22,500 mi.	Every 6,000 mi.
Points and condenser replacement	Not needed because there are none.	Every 6,000 mi.
Chassis lubrication	Every 6 mos. or 7,500 mi.	Every 4 mos. or 6,000 mi.
Transmission fluid change	Every 30,000 mi.	Every 24,000 mi.

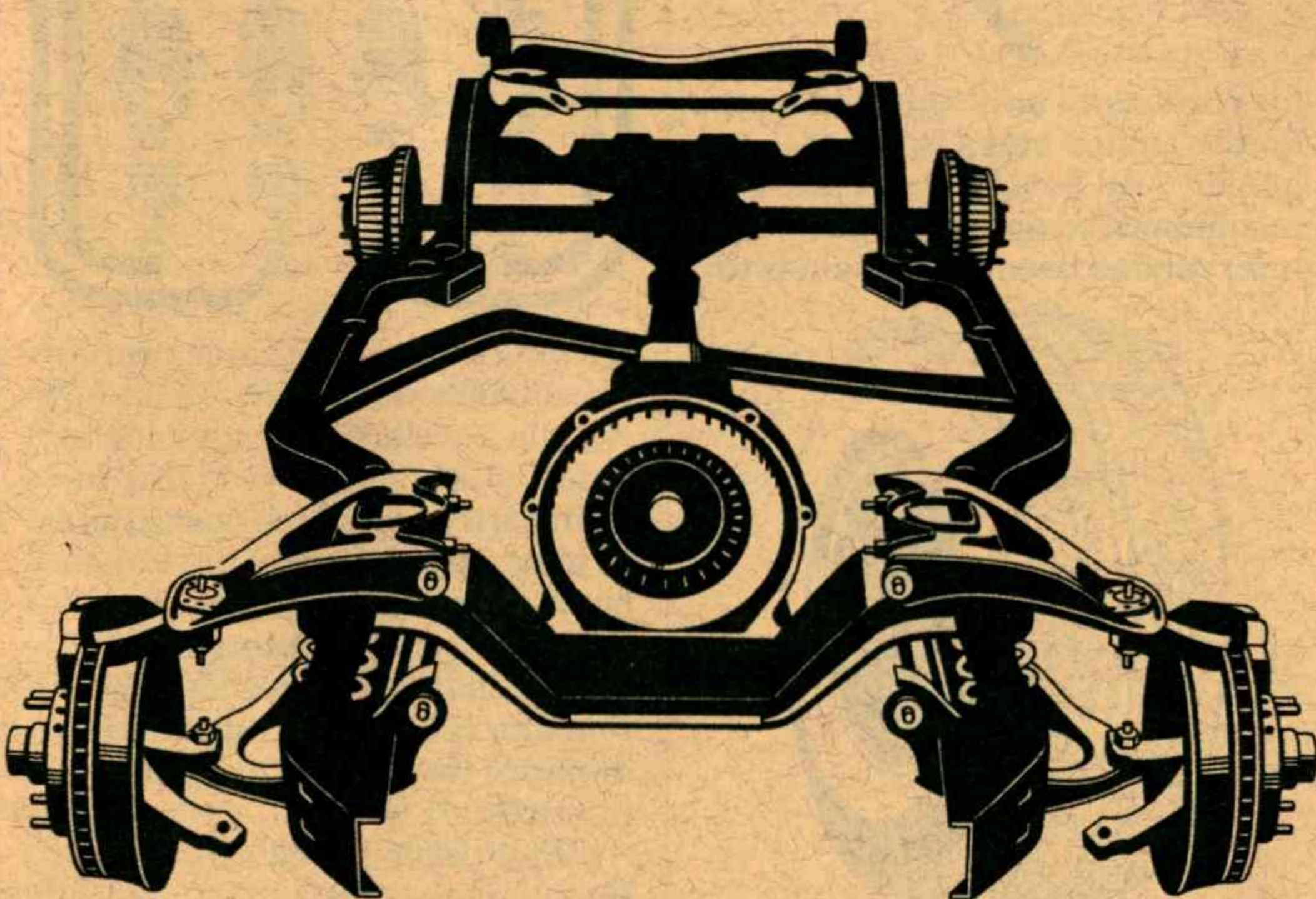

**THE CHASSIS.
THE DICTIONARY SAYS IT'S
A FRAME. WE SAY IT'S
A WHOLE LOT MORE.**

Considering the thousands of parts that go into a car, it's understandably difficult to define subassemblies and major assemblies perfectly. But, when we at Buick say "chassis", we're talking about the frame, power-train (engine, transmission, and axle), suspension and braking systems. A lot of nuts and bolts maybe, but all those parts contribute to the riding qualities for which Buick is so well known.

A logical starting point is the frame. Skyhawk is built of unit-body construction, which means the body and frame are integral. Keeping it simple, that means light weight with high structural strength—a good design for a subcompact car.

Skylark utilizes semi-unit construction. Similar to Skyhawk, except the engine and front suspension are mounted on a separate sub-frame. Which helps isolate vibration and road shock.

Century and full-size Buicks are built on full-perimeter frames—which means the body and frame are constructed independently of each other. This design gives a solid foundation for the body, which is generously cushioned at each point of attachment. Likewise, engine and sus-

pension units are cushioned and isolated, in order to help trap road shock.

Six different transmissions help tailor engine power to driver requirements. Three manually, three automatically. The familiar 3-speed manual is standard in several economy-model Buicks, (not available in California) while a 4-speed manual is standard in Skyhawk. (A 5-speed overdrive transmission is available in Skyhawk this year.) Turbo Hydramatic automatic transmissions come in three different versions, for specific application to different model Buicks.

Our transmissions leave the factory only after thorough and tough testing. Balance tests. Leak tests. And each transmission is hooked up to a machine that runs it through the gears, forward and backward, just as you do when driving.

You normally don't ponder axle ratios, but they are a vital link in the driveline system and have a great deal to do with the efficiency of your car. Enough so that we've lowered some rear axle ratios for 1976 to help improve fuel economy.

Road imperfections are nicely absorbed by Buick's computer-selected springs. A Buick Century Regal equipped with air conditioning obviously weighs more than a Regal without air

conditioning, and thus requires different springs. A computer tells which springs are right for your specific car. Other benefits of computer-selected springs include better height control and consistent ride and maneuvering characteristics.

We'd be amiss without mentioning bumpers. Pleasing to the eye, yet functional. Front and rear bumper systems retract upon impact to absorb shock. And we've added rubber bumper protective strips on most models, for added protection against "acoustical parkers".

Disc brakes are a major advance in the science of stopping. All 1976 Buicks have front disc brakes as standard equipment, some with power boosters. What it means to you is fade-resistant braking. In addition, a proportioning valve helps keep Buick Coupes and Sedans on an even keel when stopping, and helps resist rear wheel lock-up, which can cause skidding.

BUICK. THE BODY BEAUTIFUL.

Many people have a hand in seeing that the interior of your Buick is as inviting, comfortable, and functional as possible. We're very proud of the work they do, and we think one look inside a Buick will convince you.

Take some of the features you

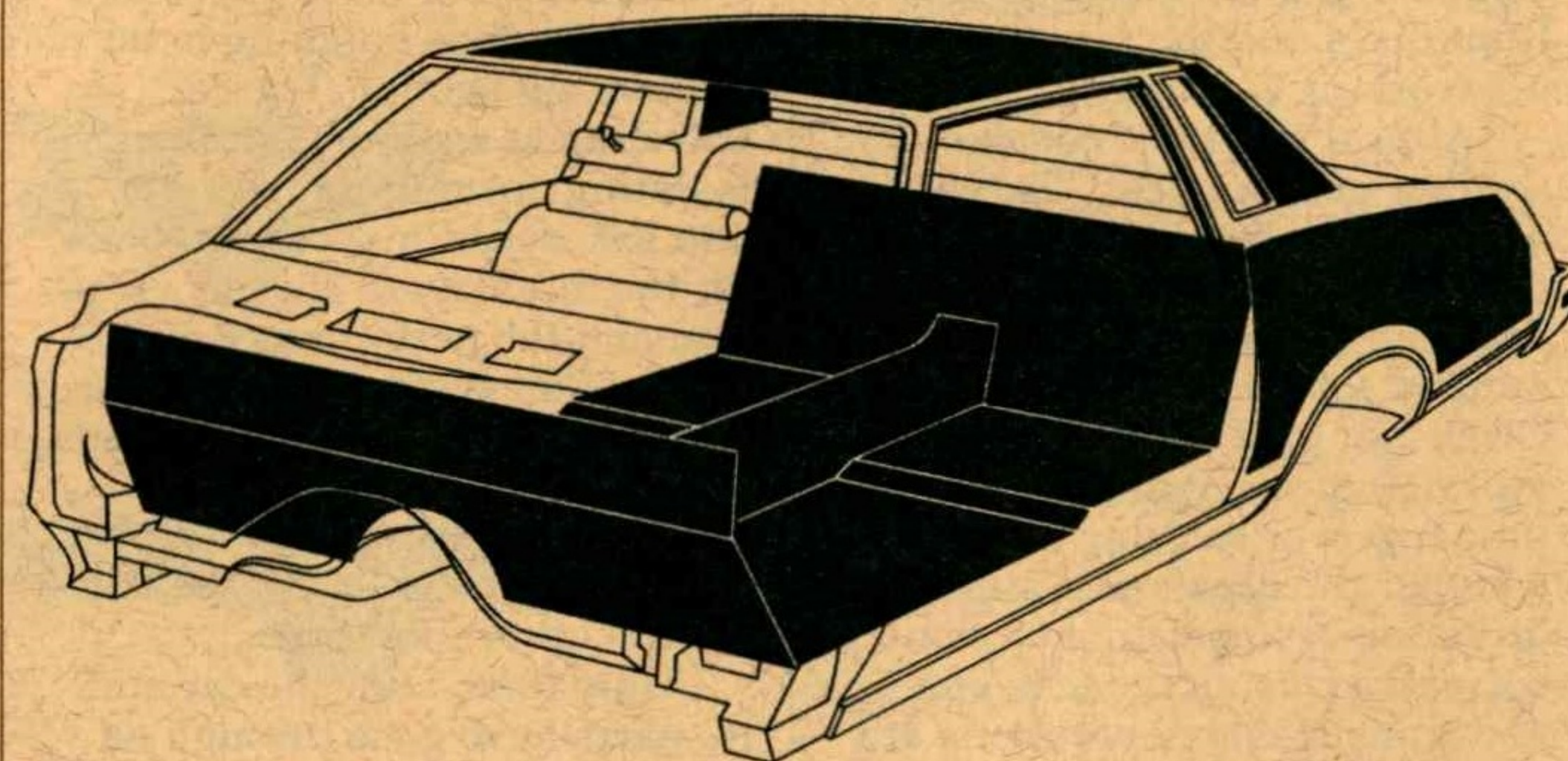

can't see—but nevertheless help contribute to a pleasing interior environment.

Additional insulation, in Buick Electra, Riviera, LeSabre and Regal, helps block out engine and rear end noise and blankets the floor underneath your feet.

All Buicks feature our Full-Flo ventilation system, which delivers a continuous flow of outside air to the interior. A blower-fan quietly and automatically keeps air circulation uninterrupted after the engine warms up.

Full-foam seat construction is standard on all Buicks. Seats are highly resilient for many miles of seating comfort, and are contour-molded for support. The "ahhs" attest to it.

Instrumentation is concise and legible. Switches and controls are located for easy identification by "feel", as well as by eye.

Naturally, you expect your Buick to retain its factory-fresh appearance. And we take numerous steps in the plant to help assure this. Corrosion protection is sprayed into hard-to-reach places. And the places we can't reach are galvanized. Enclosed areas feature drainage panels to keep water out. And finally, each Buick receives five layers of "skin", including primer, sealer, and multiple applications of high-luster acrylic lacquer.

There's more, but you get the point. Quality abounds throughout every Buick we build. We demand it. You get it.

**IMPORTANT IMPROVEMENTS
IN THE 1976 BUICKS.**

We at Buick are continually looking for ways to improve the cars we build. 1976 is a good example of that.

■ The big news, of course, is our mid-size cars. Nine Century models have all been redesigned. With smooth, new styling, rectangular headlamps, and three new front end designs: there's a formal grille for Regal Coupes, a canted, aerodynamic nosepiece for other Century Coupes, and an entirely different front end, with vertically-stacked headlamps, for 4-door models.

■ Regal, along with LeSabre, Riviera, and Electra, have added sound insulation surrounding the passenger compartment. (There's even insulation under the seats to help prevent noise and vibration from wriggling in).

■ On Skyhawk, a 5-speed, floor-mounted, manual transmission is available. The 5th gear is an overdrive, which means the engine turns fewer revolutions per highway mile.

■ LeSabre, Riviera, and Electra each have a lower standard rear axle ratio for improved overall fuel economy. Other mileage-improving features include: a redesigned quadrajet carburetor, increased spark advance, and a new camshaft for 5.7-litre V-8's.

EVERY NEW BUICK IS A TESTED BUICK.

In this day and age, a car should be viewed as an investment. Pleasantly, a Buick is often considered one. Which is testimony to the generally tight way we build Buicks, and the decidedly tough way we test them before they leave the factory. To demonstrate that, let's follow a new Buick through its final series of tests.

At the end of the assembly line, the car is started and driven off with authority. Then the inspector slams on the brakes. Skid pads in the floor (connected to a

computer) tell instantly if the front discs and the rear drums are working correctly.

After the brakes, comes another grueling test. The car is driven onto the rollers of a dynamometer. The rollers begin to spin and a speed of 60 mph is quickly achieved. The inspector checks for axle noise, driveline vibrations, speedometer accuracy, proper power steering assist, and whether the heater and air conditioning systems are functioning correctly. During the test, engine and transmission operations are verified by putting the vehicle through controlled accelerations, decelerations, and power shifts.

Now the car moves over to a group of rollers spinning in an undulating fashion. The car, traveling at a simulated 35 mph, is listing abruptly to the right and left, as the inspector checks for the intensity of chassis vibration and the performance of the suspension system under stress.

The final test is for front end alignment. While this is happening, a group of inspectors checks the underside of the car for any oil or fluid leaks.

Only then, after the car and its parts have gone through an amazing 5,517 tests and checks, is a new Buick approved for shipping.

We don't stop there. To help assure our cars are of quality construction, we select approximately two percent of the cars we build each day, at random, for what is called the Final Car Audit.

The Final Car Audit is literally a bumper-to-bumper, tires-to-top inspection of the car. Each car is assigned to an auditor who spends four hours testing and grading the exterior finish, the interior finish, and all mechanical functions. Included, is a 13-mile test-drive. The drive covers city streets, residential streets, smooth roads, bumpy roads, and freeways. And during the course of the drive, each Buick is evaluated with a most critical eye.

The value of the Audit comes every morning when the Director of the Audit holds a meeting attended by the Plant Managers, their Assistants, line Foremen, and, in some cases, the people who assemble the cars. The Director reports on the previous day's Audit, critiques the performance of the final assembly operation, and the men discuss ways they can improve the production quality of the Buicks they make.

Our assembly plant testing and the Final Car Audit are done for one reason: to make sure your new Buick is everything you expect a Buick to be.

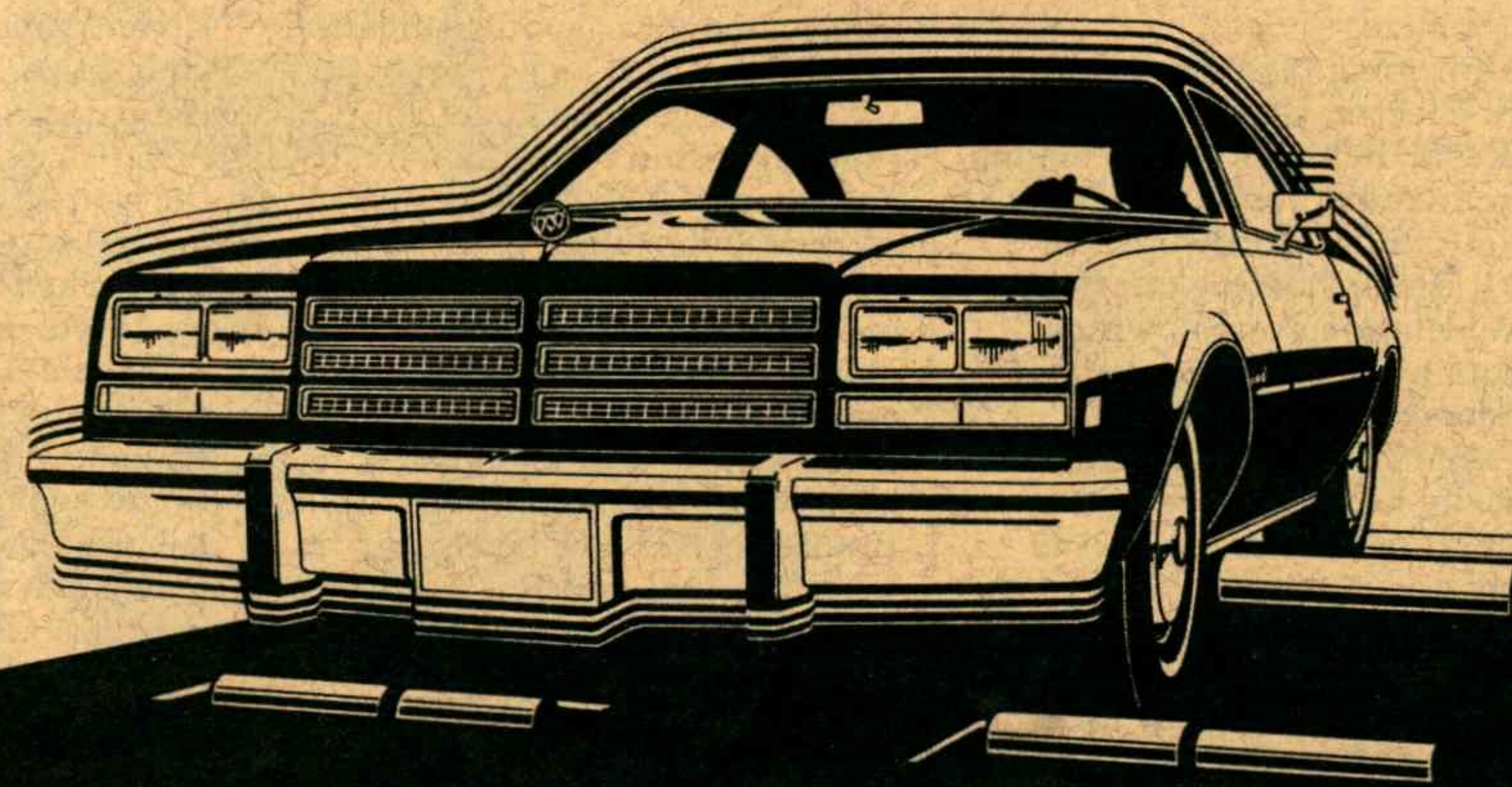

The selection of your car: an important decision.

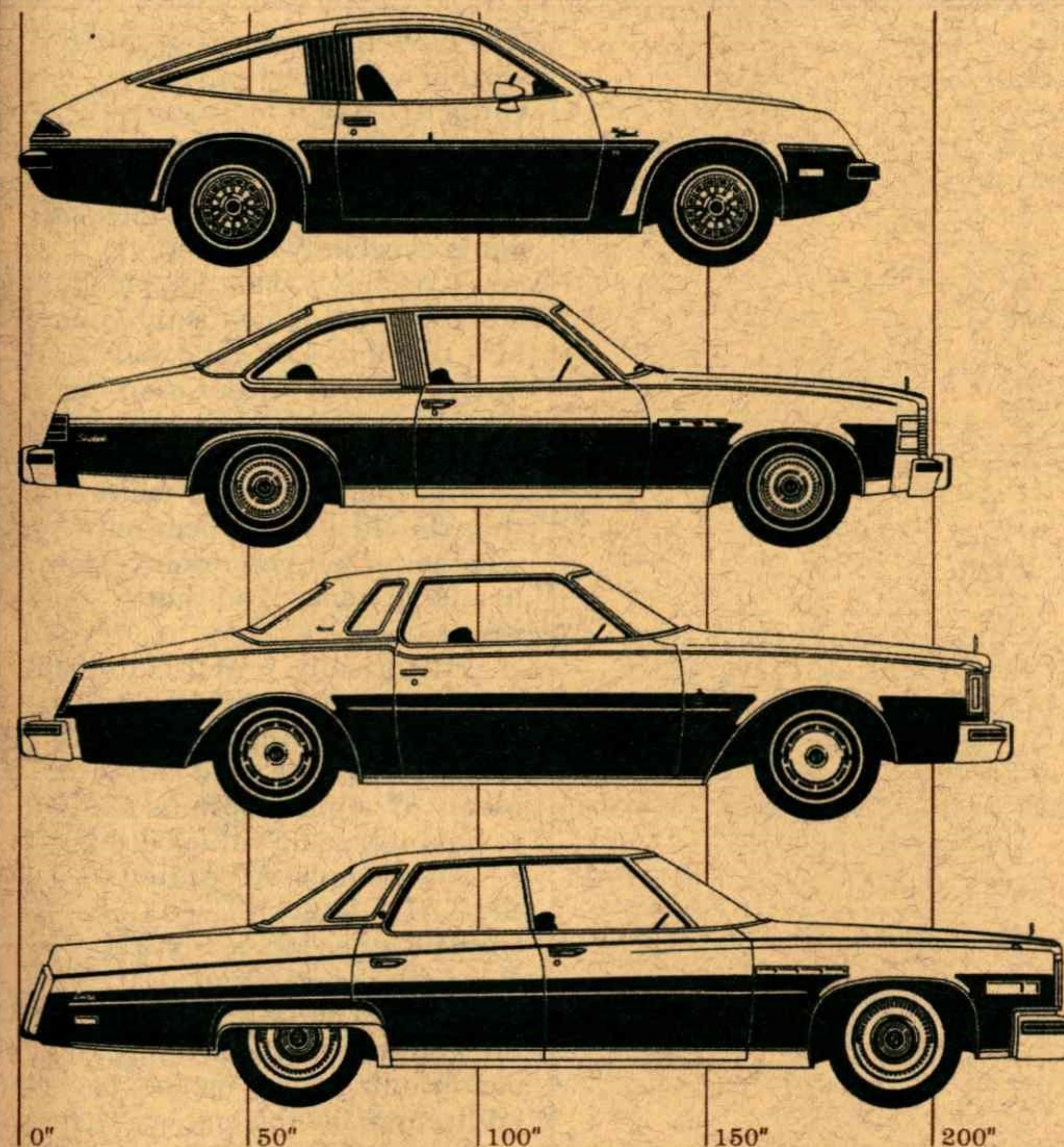

As we indicated earlier, the car-buying habits of the American public have been undergoing a number of radical changes. We Americans are keeping our cars longer—the average trade-in

is now close to four years old. And the cars we're buying are different. Clearly, the trend is to smaller, yet more luxurious vehicles with special accent on creature comforts. Economy of operation is

also a new consideration. Which is reflected in the increased popularity of 6-cylinder engines. At the beginning of this decade, 6-cylinder engines were specified in 11% of the new cars. Last year that figure rose to almost 19%.

Buick is aware of the changing preferences of the American car buyer. And our Buick line for 1976 includes a full range of cars, from the sporty, subcompact Skyhawk, all the way to the full-size Electra. We have a newly-styled, mid-size car in Century. And, quite frankly, we think our Buick V-6 engine, with its blending of economy and spirited performance, is perfectly suited for the times.

The purpose of these few paragraphs, then, is to introduce you to the many different sizes and types of Buicks for 1976.



Our subcompact Skyhawk has a 97-inch wheelbase, is 50.1 inches tall, and 65.4 inches wide. It's a 2-plus-2 Hatchback Coupe, which means it seats two in front, two in back and has a door in the rear that opens on a 28-cubic foot cargo area (with the rear seat folded down). Skyhawk's size, its rakish design, and its economical V-6 engine make it a perfect example of

the new breed of Buicks we are building.



Our compact Skylark has a 111-inch wheelbase, is approximately 53.1 inches tall, (depending on body style) and 72.7 inches wide. It comes in 4-door, 2-door, and Hatchback models. Skylark's small size makes it nimble in traffic, and its standard V-6 engine further establishes it as a good city car. Yet Skylark is ample enough inside to be quite enjoyable on long trips. And when you couple Skylark's good highway mileage with its large 21-gallon gas tank, you've got something called range. Which simply means you can put a lot of miles behind you on a single tank of gas.



Our mid-size Century has a 112-inch wheelbase (116-inch on 4-door and Wagon models), is approximately 53 inches tall, and is 77 or 79 inches wide (depending on body style). But numbers alone do not do Century justice. It is a car of seemingly infinite personalities—from the richly-appointed Regal S/R to the utilitarian Century Special. →

A look at options.

(continued from page 57)
Available in 2-door, 4-door and Wagon models, with a choice of three different front end treatments and four different roof-lines, Century is a car that you can literally custom-tailor to be just about anything you want: elegant and sporty, elegant and economical, sporty and economical—you name it. Initially, the selection may seem a bit confusing, but the reason for it is sound: to offer a group of mid-size cars that can become very personally yours and yet remain very Buick.



Our personal/luxury car, Riviera, has a 122-inch wheelbase, is 53 inches tall, and 80 inches wide. It comes in one body style—a Coupe—and offers comfort and convenience features in abundance.

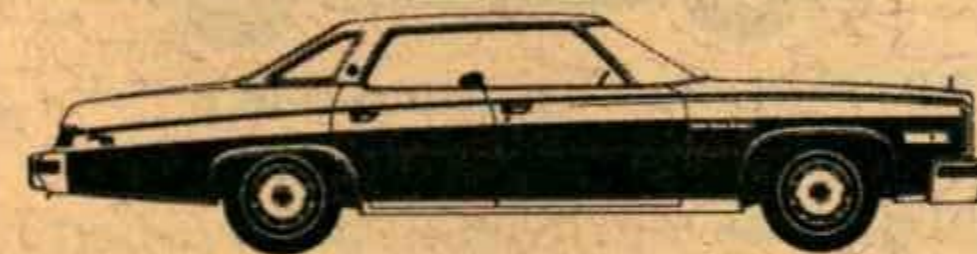

Our full-size family car, LeSabre, has a 124-inch wheelbase, is approximately 54 inches tall (depending on body style), and is 79.9 inches wide. There are three LeSabre Customs. A Coupe, a Hardtop Sedan, and a 4-door Sedan. LeSabre has a huge trunk,

generous interior room, and a long wheelbase, which contributes to a very comfortable ride. As such, it is a near-perfect family or business car.



The ultimate Buick, Electra, has a 127-inch wheelbase, is approximately 54 inches tall, and is 79.9 inches wide. There is an Electra 225 2-door and 4-door, and an Electra Limited 2-door and 4-door. The difference is largely interior trim level: the Limited being slightly more opulent.

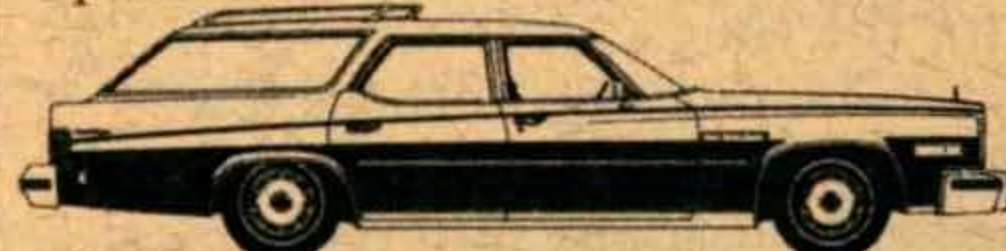

The Estate Wagon has a 127-inch wheelbase, is approximately 57 inches tall, and 79.9 inches wide. There are 2- and 3-seat models, with 105.7 cubic feet of cargo area in both. Estate Wagons offer the luxury of a full-size Buick with the practicality of a wagon.

PLEASE NOTE.

1976 fuel economy figures for all Buick models, certified by the Environmental Protection Agency, are available upon request at all Buick dealerships.

The obvious reason you specify certain equipment on a new car is to make it a direct extension of your wants and needs. If you travel a lot, you may want air conditioning. If your musical ear is especially demanding, you'll probably want an AM-FM stereo. Or if you just want your new Buick to look especially sporty, you may order road wheels, or pinstriping and/or sport mirrors.

But there's another factor that should come to bear on whether or not you order certain available items. And that's resale value.

Historically, a well-equipped used car is easier to sell than one that's not. And because it's easier to sell, the used car with plenty of popular options tends to hold its resale value better.

An example: According to the NADA Official Used Car Guide (June, 1975, Central Edition), the owner of a 1973 Electra can add \$300 to the retail value of his car if it has air conditioning. That means, in addition to having enjoyed the comforts of air conditioning, he gets back two-thirds of its original manufacturers' suggested retail price when he sells his car.

The following chart will be helpful in comparing what is standard and what is available on the different Buick models.

Some 1976 Buick Available Equipment

	Skyhawk	Skyhawk	Century/ Century Custom	Regal	Century Custom Station Wagons	LeSabre Custom	Estate Wagon	Electra 225/ Electra Limited	Riviera		Skyhawk	Skyhawk	Century/ Century Custom	Regal	Century Custom Station Wagons	LeSabre Custom	Estate Wagon	Electra 225/ Electra Limited	Riviera
Chassis Equipment																			
Power brakes—front disc	A	A	A#	S	S	S	S	S	S	AM-FM stereo radio with single front and rear speakers	A	A							
Firm ride and handling package	A	A	A	A	A	A	A	A	A	Rear seat speaker (single)	A	A	A	A	A	A	A	A	A
Automatic level control			A	A	A	A	A	A	A	AM or AM-FM stereo radio and stereo tape player		A	A	A	A	A	A	A	A
Heavy-duty wheels			A	A	S	A	S	A	A	AM-FM stereo radio with front and rear dual speakers			A	A	A	A	A	A	A
Heavy-duty engine and transmission cooling			A	A	A	A	A	A	A	Automatic-power mast antenna							A	A	A
Engine block heater			A	A	A	A	A	A	A	"Headlamps on" indicator	A	A	A	A	A	A	A	A	A
Heavy-duty air cleaner			A	A	A	A	A	A	A	Lighted visor vanity mirror			A	A	A	A	A	A	A
Heavy-duty battery			A	A	A	A	S	S	S	Dome reading light			A	A	A	A	A	A	A
Freedom battery (maintenance free)	S	A	A	A	A	A	A	A	A	Door courtesy & warning lights							A	A	A
Positive-traction rear axle	A	A	A	A	A	A	A	A	A	Astrorof—fixed glass	A								
Comfort and Convenience Equipment																			
Variable-ratio power steering	A	A	S	S	S	S	S	S	S	Astrorof—sliding glass (coupes only)									A
Stowaway spare tire	S*	A*	S**	A						Roof crown molding	A								A
Climate-Control air conditioning	A	A	A	A	A	A	A	A	A	Appearance & Protection Equipment									
Automatic Climate-Control air conditioning									A	Remote tailgate release									A
Custom-Aire air conditioning			A	A	A	A	A			White billboard lettered tires	A	A	A	A					
Electric sun roof (coupes only)			A	A					A	Wheel covers	A	A	A	S	A	S	S	S	S
Hurst hatch-roof (coupes only)			A	A						Speed alert			A	A	A	A	A	A	A
Tilt steering wheel	A	A	A	A	A	A	A	A	A	"Low fuel" indicator light									A
Tilt and telescoping steering column							A	A	A	Fuel usage indicator	A								
Electric trunk release			A	A	A		A	A	A	Fuel usage gauge			A	A	A	A	A	A	A
Electric door locks			A	A	A	A	A	A	A	Special appearance or treatment moldings			A	A	A	A	A	A	A
Electric door and seatback locks (coupes only)							A	A	A	Front light monitors								A	A
Automatic power door locks									A	Front and rear light monitors									A
Cruise-Master speed control			A	A	A	A	A	A	A	Sport mirror (left side remote-control)	S	A	A	A	A	A			A
Accessory group lights	A	A	A	A	A	A	A	A	A	Sport mirror (right side)	A	A	A	A	A	A			A
Electric clock	S	A	A	A	A					Remote-control outside rear view mirror (left)			A	A	A	A	A	S	S
Electronic quartz-crystal digital clock							A	A	S	Remote-control outside rear view mirror (right)								A	A
Power windows			A	A	A	A	A	S	S	Bumper guards†	S	A	A	A	A	A	A	A	A
Rear-window defogger (blower)			A	A	A		A	A	A	Bumper protective strips	S	A	S††	S	S	S	S	S	S
Rear-window defogger (electric)	A		A	A	A	A	A	A	A	Protective side moldings	A	A	A	A	A	A	A	A	A
Cornering lights							A	A	A	Air restraint system								A	A
3-speed windshield wiper with low-speed delay feature			A	A	A	A	A	A	A	Oil pressure and temperature gauges	S		A	A					
2-speed windshield wiper with low-speed delay feature			A							Interior Equipment									
Soft-Ray tinted glass	A	A	A	A	A	A	A	A	A	Carpet savers and handi-mats	A	A	A	A	A	A	A	A	A
Outside thermometer							A	A	A	Litter pocket			A	A	A	A	A	A	A
Operating console	A	A	A	A	A				A	6-way power seat			A	A	A	A	A	A	A
AM radio	A	A	A	A	A	A	A	A	A	About Trailer Towing Equipment									
AM-FM radio	A	A	A	A	A	A	A	A	A	Buick offers trailer towing equipment designed to meet your specific towing requirements.									
										Ask your Buick dealer for complete details.									

#Standard on Century Custom Sedan.

*Hatchback Models.

††Except Special.

**Century Special only. Available on other models except Station Wagons.

†Rear guards are required on Century Custom Station Wagons and Riviera in Md., Calif. & Florida. A special bumper system is required on Electra models in Md., Calif. & Florida.

The 1976 Skyhawk: an inspection.

Standard 3.8-litre Buick V-6 engine offers economy and performance. Significantly, the only V-6 engine designed and built in the U.S. is from Buick. It shares many components with Buick V-8's.

Freedom battery. Small and powerful, it requires no periodic maintenance and has a built-in "state of charge" indicator which lets you know at a glance if the battery needs recharging.

Anti-theft steering column lock locks steering wheel in place when key is removed from ignition.

2-plus-2 seating, ala the great European road cars. Skyhawk seats two in front, two in back.

Hatchback door allows for convenient access to cargo area.

Cargo space. With back seat folded down Skyhawk has 28 cubic feet of cargo space.

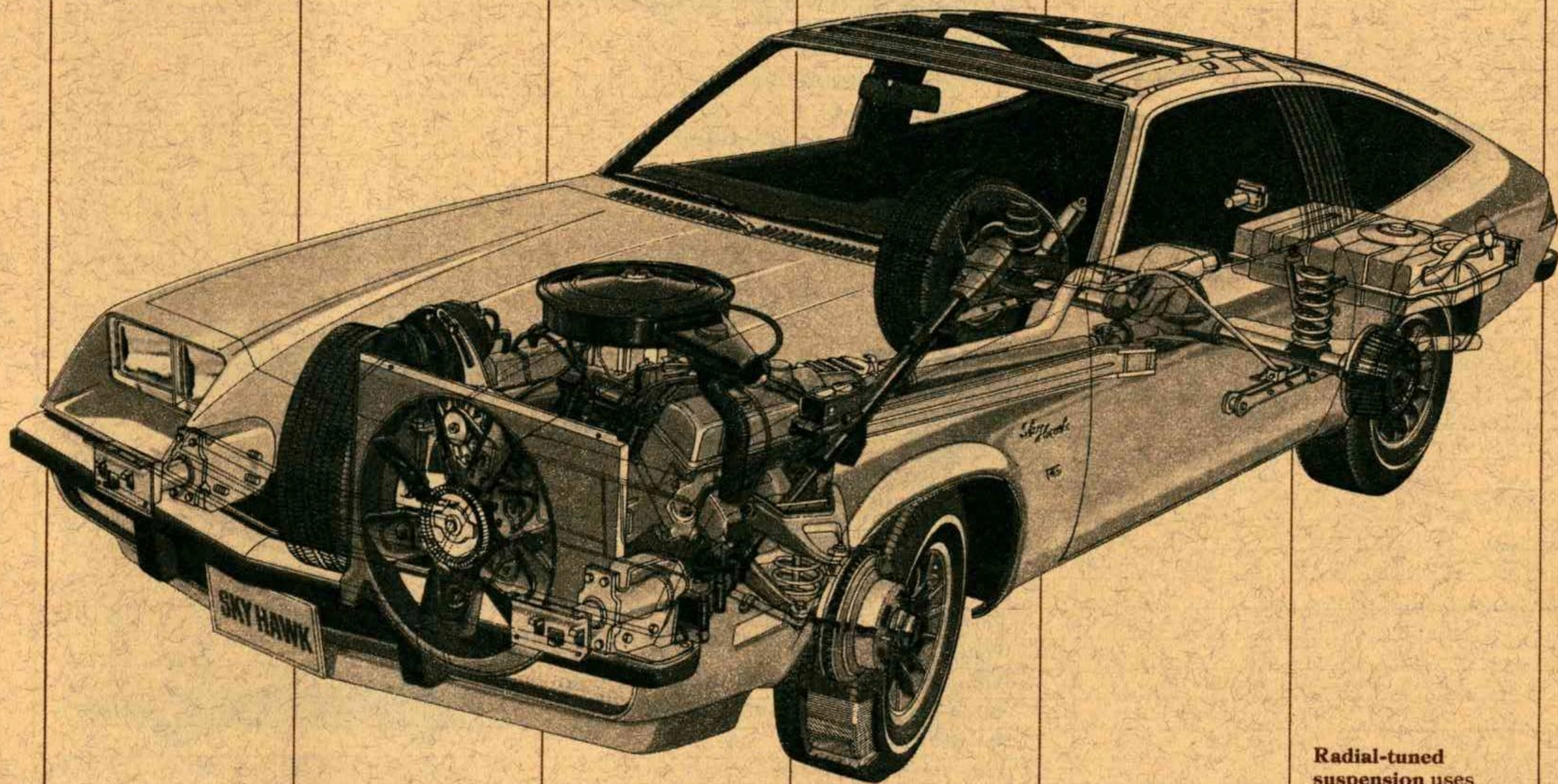

Oil pressure switch connected to fuel pump, shuts off fuel supply if for any reason oil pressure falls below normal operating limit.

Stabilizer bars, front and rear, contribute to Skyhawk's maneuverability. (Skyhawk "S" has front stabilizer bar only.)

Brake lining wear sensor on each in-board disc brake pad produces an audible squeak when replacement is needed.

Front disc brakes with vented rotors effectively dissipate heat for more fade-resistant stopping.

Available 5-speed overdrive transmission allows engine to turn fewer revolutions per highway mile.

Radial-tuned suspension uses computer-selected springs, front stabilizer bar and rear stabilizer bar (not on Skyhawk "S") and special suspension geometry, coordinated with radial tires.

DIMENSIONS.

Dimensions (inches, unless otherwise noted)	Hatchback Coupe
Wheelbase	97.0
Tread, front	54.7
Tread, rear	53.6
Length	179.3
Width	65.4
Height	50.1
Head room, front	37.7
Head room, rear	35.3
Leg room, front	42.8
Leg room, rear	29.6
Shoulder room, front	51.0
Shoulder room, rear	51.2
Hip room, front	47.5
Hip room, rear	42.0
Cargo volume index (cu. ft.)	27.8
Length of load floor (rear seat folded down)	61.9

MODEL AVAILABILITY.

Skyhawk 'S' — Hatchback-4HT07
Skyhawk — Hatchback-4HS07

STANDARD EQUIPMENT.

Engine

- 3.8-litre (231 C.I.D.), 2 bbl. V-6
- Catalytic converter
- Semi-closed cooling system
- High-Energy Ignition

Chassis

- 4-speed manual transmission fully synchronized in all forward gears
- Manual steering
- Manual brakes with front discs
- Unitized construction
- Steel-belted radial-ply BR78-13 tires on Skyhawk
- Bias-ply B78-13 tires on Skyhawk 'S'
- Freedom battery (maintenance free)
- Stowaway spare tire

Interior

- Choice of cloth bucket seats or vinyl bucket seats
- Full-foam seat construction
- Cut-pile carpeting—front and rear
- Load floor carpeting
- Full-Flo ventilation

Appearance and Protection

- Strong, reinforced front and rear energy-absorbing bumpers
- Bumper guards—front and rear
- Side window reveal moldings
- Bumper protective strips
- White, gold or black accent stripes

AVAILABLE EQUIPMENT.

Chassis

- 5-speed manual transmission
- Full-length operating console
- Turbo Hydra-matic transmission
- Variable-ratio power steering
- Power front disc brakes
- California assembly line emission testing

(required in California)

- Steel-belted radial-ply whitewall tires
- Steel-belted radial-ply blackwall tires on Skyhawk 'S'
- Bias-ply whitewall tires on Skyhawk 'S'
- Steel-belted radial-ply white billboard lettered tires
- Positive-traction differential
- Handling package (includes rear stabilizer bar and steel-belted radial-ply blackwall tires) for Skyhawk 'S' only (standard on Skyhawk)
- Heavy-duty battery
- Conventional spare tire

Interior

- Front and rear floor mats
- Adjustable driver seatback

Comfort & Convenience

- AM Radio
- AM-FM Stereo Radio including single front and rear speakers
- AM-FM Radio
- Rear speaker
- Climate-Control air conditioner
- Electric rear window defogger
- Left hand remote-control outside rear view sport mirror on Skyhawk 'S' (standard on Skyhawk)
- Right hand manual sport mirror
- Tilt steering wheel
- Electric clock
- Electric clock and tachometer
- Convenience group includes: day/night mirror, engine compartment and glove box lights & "headlamps on" indicator
- Soft-Ray tinted glass
- Soft-Ray tinted windshield
- Shadow light astroroof and roof crown molding
- Skyhawk 'S' package

Appearance & Protection

- Color-coordinated custom front and rear seat belts (2 each) and front shoulder belts (2)
- Door guards
- Deluxe wheel covers
- Rallye steering wheel
- Wheel trim rings
- Custom sport wheels
- Protective body side molding
- Roof crown molding

YOUR ORDERING GUIDE. 1976 SKYHAWK.

Model selected:

Be sure to consider: (mark your choices).

- Turbo Hydra-matic automatic
- 5-speed manual overdrive
- Variable-ratio power steering
- Positive-traction differential
- Heated glass rear window defogger
- Climate-Control air conditioner
- Console in Skyhawk 'S'
- Power front disc brakes
- Additional instrumentation on Skyhawk 'S'
- Astroroof with fixed glass & roof crown molding
- Roof crown molding
- AM radio
- AM-FM stereo radio including single front and rear speakers
- AM-FM radio

Write in additional selections here:

The 1976 Skylark: an inspection.

Many luxury items are available on Skylark. Including: Cruise-Master speed control, power windows, automatic trunk release, and various stereo sound systems.

European-style dimmer switch on S/R models is located in the turn signal lever. It allows you to dim your headlamps without removing your hands from the steering wheel.

Generous glass area. Skylark's "greenhouse" offers plenty of glass area for visibility, night or day.

Reclining passenger seat on Skylark S/R offers added relaxation during long trips.

Available electric door locking system. By depressing the door lock switch on one door and closing it, you lock all doors.

Plentiful 21-gallon gas tank, combined with Skylark's V-6 engine, offers generous cruising range between fill-ups.

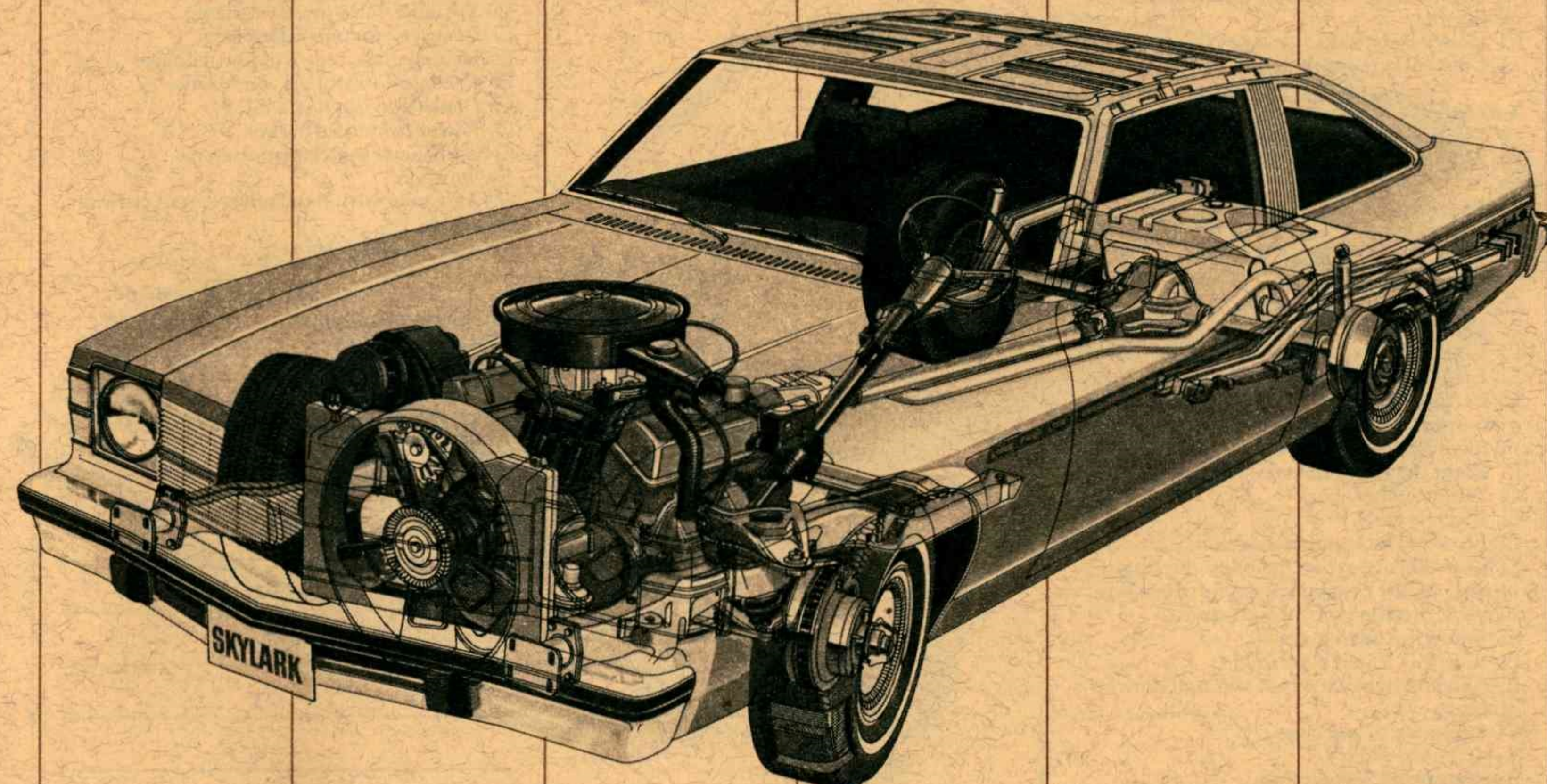

Standard 3.8-litre Buick V-6 Engine offers economy and performance. Significantly, Buick Skylark is the only V-6 powered American compact.

High-Energy Ignition eliminates need for points and ignition condenser and contributes to extended spark plug change interval. Up to 22,500 miles.

Brake lining wear sensor on each in-board disc brake pad produces an audible squeak when replacement is needed.

Front Disc brakes. Standard on Skylark.

Extended transmission maintenance intervals. Under normal driving conditions, the transmission oil and filter need changing only after 30,000 miles.

Radial-tuned suspension on Skylark S/R uses computer-selected springs, front stabilizer bar and special suspension geometry, coordinated with radial tires.

DIMENSIONS.

Dimensions (inches, unless otherwise noted)	Hatchback Coupes	2-door Coupes	4-door Sedans
Wheelbase	111.0	111.0	111.0
Tread, front	59.1	59.1	59.1
Tread, rear	59.7	59.7	59.7
Length	200.3	200.3	200.3
Width	72.7	72.7	72.7
Height	52.1	52.1	53.1
Head room, front	38.3	38.3	39.3
Head room, rear	36.6	36.6	36.6
Leg room, front	41.7	41.7	41.7
Leg room, rear	33.4	33.4	35.3
Shoulder room, front	55.6	55.6	56.6
Shoulder room, rear	55.3	55.3	56.2
Hip room, front	55.2	55.2	55.9
Hip room, rear	55.0	55.0	54.9
Trunk volume (cu. ft.)		14.2	13.6
Cargo volume index (cu. ft.)	28.4		
Length of load floor (rear seat folded down)	76.2		

MODEL AVAILABILITY.

Skylark 'S'	- Coupe	-4XW27
Skylark	- Coupe	-4XB27
	- Hatchback	-4XB17
	- Sedan	-4XB69
Skylark S/R	- Coupe	-4XC27
	- Hatchback	-4XC17
	- Sedan	-4XC69

STANDARD EQUIPMENT.

Engine

- 3.8-litre (231 C.I.D.), 2bbl. V-6
- Catalytic converter
- Semi-closed cooling system
- High-Energy Ignition

Chassis

- 3-speed manual transmission fully synchronized in all forward gears (available only with six-cylinder engine and not available in California)
- Manual steering
- Manual brakes with front discs
- Step-on parking brake
- Separate front frame unit cushion-mounted to unitized body
- Bias-belted E78-14 tires on Skylark 'S', Skylark
- Steel-belted radial-ply FR78-14 whitewall tires on Skylark S/R
- Stowaway spare tire on Hatchback models

Interior

- Vinyl bench seat in Skylark 'S'
- Choice of vinyl bench or cloth bench seat in Skylark
- Special cloth bucket seats with reclining feature on passenger side in Skylark S/R
- Cut-pile carpeting—front and rear
- Load floor carpeting in Hatchback Coupes
- Rallye steering wheel in Skylark S/R
- Carpeted door trim with map pocket and reflector in Skylark S/R
- Combination turn signal and high/low beam control in Skylark S/R
- Sports shifting console in Skylark S/R
- Full-Flo ventilation
- Full-foam seat construction
- Front and rear ashtrays in Skylark & Skylark S/R

Appearance and Protection

- Strong reinforced front and rear energy-absorbing bumpers
- Stand-up hood ornament on Skylark S/R
- Roof drip moldings on Skylark & Skylark S/R

AVAILABLE EQUIPMENT.

Engine

- 4.3-litre (260 C.I.D.), 2-bbl. V-8
- 5.7-litre (350 C.I.D.), 2-bbl V-8 (N.A. in California)
- 5.7-litre (350 C.I.D.), 4-bbl V-8

Chassis

- Power front disc brakes
- Variable-ratio power steering
- Full-length operating console
- Turbo Hydra-matic transmission
- Steel-belted radial-ply whitewall tires
- Steel-belted radial-ply blackwall tires on Skylark 'S', Skylark
- Bias-belted whitewall tires on Skylark 'S', Skylark
- Steel-belted radial-ply white billboard lettered tires
- Positive-traction differential
- Firm ride and handling suspension (recommended for trailer towing)
- Rallye ride and handling suspension
- Heavy-duty cooling
- Engine block heater
- Dual horns
- Heavy-duty battery
- Trailer tow flasher and harness
- California assembly line emission testing (required in California)

Interior

- Vinyl bucket seats in Skylark
- Custom cloth bench seat in Skylark
- Custom vinyl bench seat in Skylark
- Carpet savers and handy mats
- Front carpet savers
- Carpeted door trim with map pocket and reflector

Comfort and Convenience

- AM radio
- AM radio and stereo tape player with single front and rear speakers

- AM-FM stereo and stereo tape player with single front and rear speakers
- AM-FM stereo radio with single front and rear speakers
- AM-FM radio
- Rear seat speaker
- Fuel usage indicator
- Climate-Control air conditioner
- 3-speed windshield wiper with low speed delay feature
- "Headlamps on" indicator
- Rear window defogger (blower)
- Remote-control outside rear view mirror
- Outside rear view sport mirrors (left remote, right manual)
- Outside rear view sport mirrors (left and right remote)
- Power windows
- Swing-out rear quarter vent window
- Soft-Ray tinted glass
- Cruise-Master speed control
- Tilt steering wheel
- Electric trunk release
- Electric door locks
- Accessory package—Day-night rear-view mirror and cigar lighter in Skylark 'S'
- Electric clock
- Rallye steering wheel

Appearance and Protection

- Color coordinated custom front and rear seat belts (3 each) and front shoulder belts (2)
- Front and rear bumper strips
- Bumper guards (front and rear)
- Bumper guards (front only)
- Door guards
- Deluxe wheel covers
- Chrome-plated wheels
- Body color styled wheels
- Deluxe wire wheel covers
- Wide rocker appearance group
- Custom door and window frame moldings
- Body side molding
- Rear deck lid molding
- Rocker panel moldings
- Appearance group (wheel opening and roof drip molding)
- Two-tone top
- Vinyl top
- Thickly-padded landau top
- White body side stripe
- Gold body side stripe
- Black body side stripe

YOUR ORDERING GUIDE. 1976 SKYLARK.

Model selected:

Be sure to consider: (mark your choices).

- 4.3-litre V-8
- 5.7-litre V-8 with 2-bbl. (N.A. in California)
- 5.7-litre V-8 with 4-bbl.
- Turbo Hydra-matic automatic
- Climate-Control air conditioner
- Air conditioning
- Power brakes
- Variable-ratio power steering
- Electric door locks
- Custom vinyl top
- AM radio
- AM radio and stereo tape player with single front and rear speakers
- AM-FM stereo radio and stereo tape player with single front and rear speakers
- AM-FM stereo radio with single front and rear speakers
- AM-FM radio

Write in additional selections here:

The 1976 Century: an inspection.

3.8-litre Buick V-6 offers economy and performance. Buick Century is the only mid-size American car powered by a V-6.

Variable-delay windshield wipers are available on Century. For light rain conditions, which don't require constant wiping, you can adjust the variable cycle control to wipe intermittently up to once every 15 seconds. Standard wipers have Demand-Wipe feature for misty conditions.

High-Energy Ignition eliminates need for points and ignition condenser and contributes to extended spark plug change interval. Up to 22,500 miles.

Inside hood-lock release helps prevent entry into engine compartment from outside the car.

Sound deadening. High-density sound deadening material is liberally applied throughout Century to give the kind of interior quiet you'd expect of a Buick.

Five layers of finish are applied to Century's exterior. One primer coat, one sealer and three coats of high-luster acrylic lacquer.

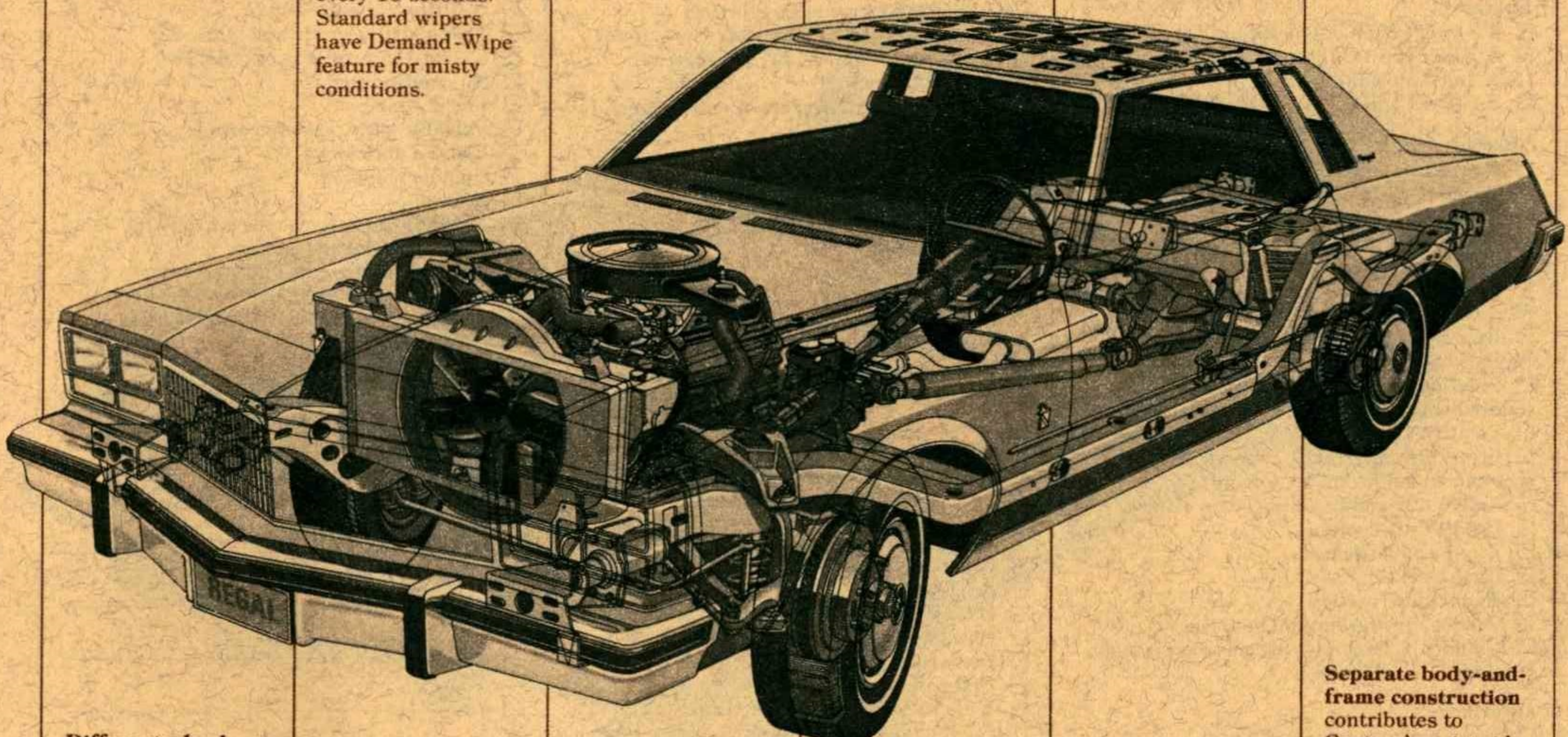

Different wheelbase lengths for Century Coupes and Sedans. The wheelbase on Century Sedans and Station Wagons is 4 inches longer than on Coupes, giving additional space for back seat passengers.

Extended transmission maintenance intervals. Under normal driving conditions, the transmission oil and filter need changing only after 30,000 miles.

Front disc brakes, standard on Century, offer stable stopping and resistance to fade. Power front disc brakes standard on Regal, Century Custom Sedan & Station Wagons.

Brake lining wear sensor on each inboard disc brake pad produces an audible squeak when replacement is needed.

Radial-tuned suspension uses computer-selected springs, front stabilizer bar and special suspension geometry, coordinated with radial tires.

Separate body-and-frame construction contributes to Century's quiet ride. The frame helps absorb road noise and vibration while the body is isolated from the frame by thick rubber body mounts. So road noise is reduced before it reaches passengers.

DIMENSIONS.

Dimensions (inches, unless otherwise noted)	Century Special, Century Custom & Regal Coupes	Century, Century Custom & Regal Sedans	Century Custom Station Wagons
Wheelbase	112.0	116.0	116.0
Tread, front	61.5	61.5	61.5
Tread, rear	60.7	60.7	60.7
Length	209.7	213.5	218.2
Width	77.0	79.0	79.0
Height	52.8 52.6*	53.6	55.8
Head room, front	37.2 37.0*	37.9	38.8
Head room, rear	36.7 37.1*	37.3	39.4
Head room, third seat	—	—	37.8
Leg room, front	42.4	42.4	42.8
Leg room, rear	32.9	37.1	36.8
Leg room, third seat	—	—	27.8
Shoulder room, front	59.6 58.8*	59.6	59.6
Shoulder room, rear	57.9 58.1*	58.9	58.9
Hip room, front	54.9	54.7	54.7
Hip room, rear	52.7	57.7	55.1
Trunk capacity (cu. ft.)	14.7	15.6	—
Cargo volume (cu. ft.)	—	—	85.1

*— Custom & Regal

MODEL AVAILABILITY.

Century Special	— Coupe-4AE37
Century	— Coupe-4AD37
	— Sedan-4AD29
Century Custom	— Coupe-4AH57
	— Sedan-4AH29
	— 2-seat Wagon-4AK35
	— 3-seat Wagon-4AK45
Century Regal	— Coupe-4AJ57
	— Sedan-4AJ29

STANDARD EQUIPMENT.

Engine

■ 3.8-litre (231 C.I.D.), V-6 in Century Special/Century/Century Custom/Regal Coupes & Century/Century Custom Sedans (N.A. in California)
 ■ 5.7-litre (350 C.I.D.), 2-bbl. V-8 in Regal Sedan (N.A. in California)
 ■ 5.7-litre (350 C.I.D.), 4-bbl. V-8 in Wagons

Chassis

■ 3-speed manual transmission in Coupes & Century/Century Custom Sedans (available only with V-6 engine and N.A. in California)
 ■ Turbo Hydra-matic in Regal Sedan & Wagons
 ■ Variable-ratio power steering
 ■ Manual front disc brakes (power assist on Custom Sedan, Regal & Wagons)
 ■ Steel-belted radial-ply GR78-15 tires (Coupes—except Special)(HR78-15 on Wagons)
 ■ Steel-belted radial-ply FR78-15 tires on Special, Century & Custom Sedans

Interior

■ Choice of cloth or vinyl bench seat in Century Special and Century
 ■ Choice of cloth or vinyl notchback seat in Century Custom Coupe, Sedan & Regal
 ■ Vinyl notchback seat in Wagons

Appearance and Protection

■ Bumper protective strips—(except Special)
 ■ "Tailgate ajar" warning light on Wagons

AVAILABLE EQUIPMENT.

Engine

□ 5.7-litre (350 C.I.D.), 2-bbl. V-8 (N.A. in California) (N.A. Century Special or Wagons, std. Regal Sedan)

□ 5.7-litre (350 C.I.D.), 4-bbl. V-8 (N.A. Century Special, Std. on Wagons)

Chassis

□ Power brakes (standard on some models)
 □ Full-length operating console
 □ Turbo Hydra-matic in Coupes & Century/Century Custom Sedans (required in Calif.)
 □ California assembly line emission testing (required in California)
 □ Steel-belted radial-ply whitewall tires
 □ Steel-belted radial-ply, white billboard-lettered, tires (N.A. Special)
 □ Positive-traction differential
 □ Firm ride and handling suspension—heavy-duty shock absorbers, springs, wheels and larger dia. front stabilizer bar (recommended for trailer towing)
 □ Automatic level control
 □ 80-amp Delcotron
 □ Freedom battery (maintenance free)
 □ Stowaway spare tire (standard on Special)
 □ Heavy-duty wheels (std. on Wagons)

Interior

□ Cloth notchback seat, vinyl notchback or vinyl bucket seats in Century and Special
 □ Vinyl bucket seats in Century Custom Sedan or Station Wagon
 □ Vinyl bucket seats, custom cloth notchback seat, custom vinyl notchback seat, custom 60/40 cloth notchback seat, custom 60/40 vinyl notchback or custom cloth bucket seats in Century Custom Coupe
 □ Custom cloth notchback seat, custom vinyl notchback seat, cloth 60/40 notchback seat, vinyl buckets in Regal Coupe & Sedan. Cloth S/R buckets (Regal Coupe only)
 □ Carpet savers and handy mats
 □ 6-way power seat (driver side only on buckets and 60/40 seats)
 □ Front and rear carpeting in Century Special
 □ Load floor area carpet in Wagons

Comfort and Convenience

□ AM radio
 □ AM radio and stereo tape player
 □ AM-FM stereo radio and stereo tape player
 □ AM-FM stereo radio
 □ AM-FM radio
 □ Rear seat speaker (single)
 □ Front and rear dual speakers
 □ Fuel usage gauge
 □ Climate-Control air conditioner

□ Custom-Aire air conditioner
 □ Speed alert
 □ 3-speed windshield wiper with low-speed delay feature
 □ "Headlamps on" indicator
 □ Electric rear window defogger
 □ Rear window defogger (blower, N.A. on Wagons)
 □ Soft-Ray tinted glass
 □ Sun roof—electric operation in Coupes
 □ Hurst Hatch on Custom & Regal Coupes
 □ Remote-control outside rear view mirror
 □ Outside rear view sport mirrors (left remote and right manual)
 □ Dome reading light
 □ Power windows
 □ Cruise-Master speed control
 □ Tilt steering wheel
 □ Electric trunk release
 □ Electric door locks
 □ Convenience group—Sunshade map, trunk, glove compartment, ash tray, and courtesy lights (on AD29 or AD37). Trunk and sunshade map lights (on AH29, AH57, AJ29 or AJ57). Sunshade map and rear compartment lights (on AK35 or AK45). Sunshade map light deleted when sun roof or dome reading light is ordered
 □ Electric clock
 □ Instrument gauges and electric clock
 □ Lighted visor vanity mirror
 □ Swing-out rear quarter vent windows (2-seat Wagon)
 □ Remote tailgate lock on Wagons
 □ Luggage rack on Wagons
 □ Air deflector on Wagons

Appearance and Protection

□ Color coordinated custom front and rear seat belts and front shoulder belts
 □ Bumper guards, front and rear (rear required in Calif., Md., Fla. on Wagons)
 □ Front and rear bumper strips on Special
 □ Custom or rallye steering wheel
 □ Deluxe wheel covers (standard on Regal)
 □ Chrome-plated wheels (N.A. Wagons)
 □ Body-color styled wheels
 □ Deluxe wire wheel covers
 □ Styled wheel covers
 □ Full, half or landau vinyl top (N.A. Wagons)
 □ Lower body side molding
 □ White, gold or black body side stripe
 □ Wood-grain vinyl applique on Wagons

YOUR ORDERING GUIDE. 1976 CENTURY.

Model selected:

Be sure to consider: (mark your choices).

□ 5.7-litre V-8 engine with 2-barrel carburetor in Coupes & Sedans (N.A. in California or on Century Special)
 □ 5.7-litre V-8 engine with 4-barrel carburetor in Coupes & Sedans (N.A. on Century Special)
 □ Turbo Hydra-matic automatic transmission in Coupes & Sedans
 □ Custom-Aire air conditioner
 □ Electric door locks and trunk release
 □ Cruise-Master speed control
 □ Heated glass rear window defogger
 □ Power windows
 □ AM-FM radio and stereo tape player
 □ AM-FM radio
 □ S/R package—(Regal Coupe)
 □ 6-way power seat

Write in additional selections here:

N.A.—Not available

The 1976 Riviera: an inspection.

Long spark plug life. Recommended change interval up to 22,500 miles. Due to use of no-lead fuel and Riviera's High-Energy Ignition System, which also eliminates points and ignition condenser.

Astrorooft with roll-away sunshade. Available on Riviera, it's actually three roofs in one. Closed, it's a regular roof. By sliding the inner shade back, you expose the tinted glass roof that lets in sunlight. Retract the glass roof, and you let in sunshine and outside air.

Available automatic door locking system. Move transmission selector to Park and all doors automatically unlock. Move it from Park and they lock automatically.

Air cushion-restraint system. Available on Riviera, it helps protect occupants in the front seat in the event of an accident.

Power windows, 2-way power seats, and a digital clock are standard on Riviera. The digital timepiece is controlled accurately by vibrations of tiny quartz crystal—vibrating at just under two million times each second.

Special paint. Stylish, two-tone treatment is available on Riviera in these combinations: Silver/Dark Red, Silver/Dark Blue, Silver/Black and Silver/Dark Gray.

DIMENSIONS.

Dimensions (inches, unless otherwise noted)	Riviera
Wheelbase	122.0
Tread, front	63.4
Tread, rear	64.0
Length	218.6
Width	79.9
Height	53.0
Head room, front	38.1
Head room, rear	37.1
Leg room, front	42.2
Leg room, rear	35.4
Shoulder room, front	63.6
Shoulder room, rear	62.4
Hip room, front	57.6
Hip room, rear	56.0
Trunk capacity (cu. ft.)	15.1

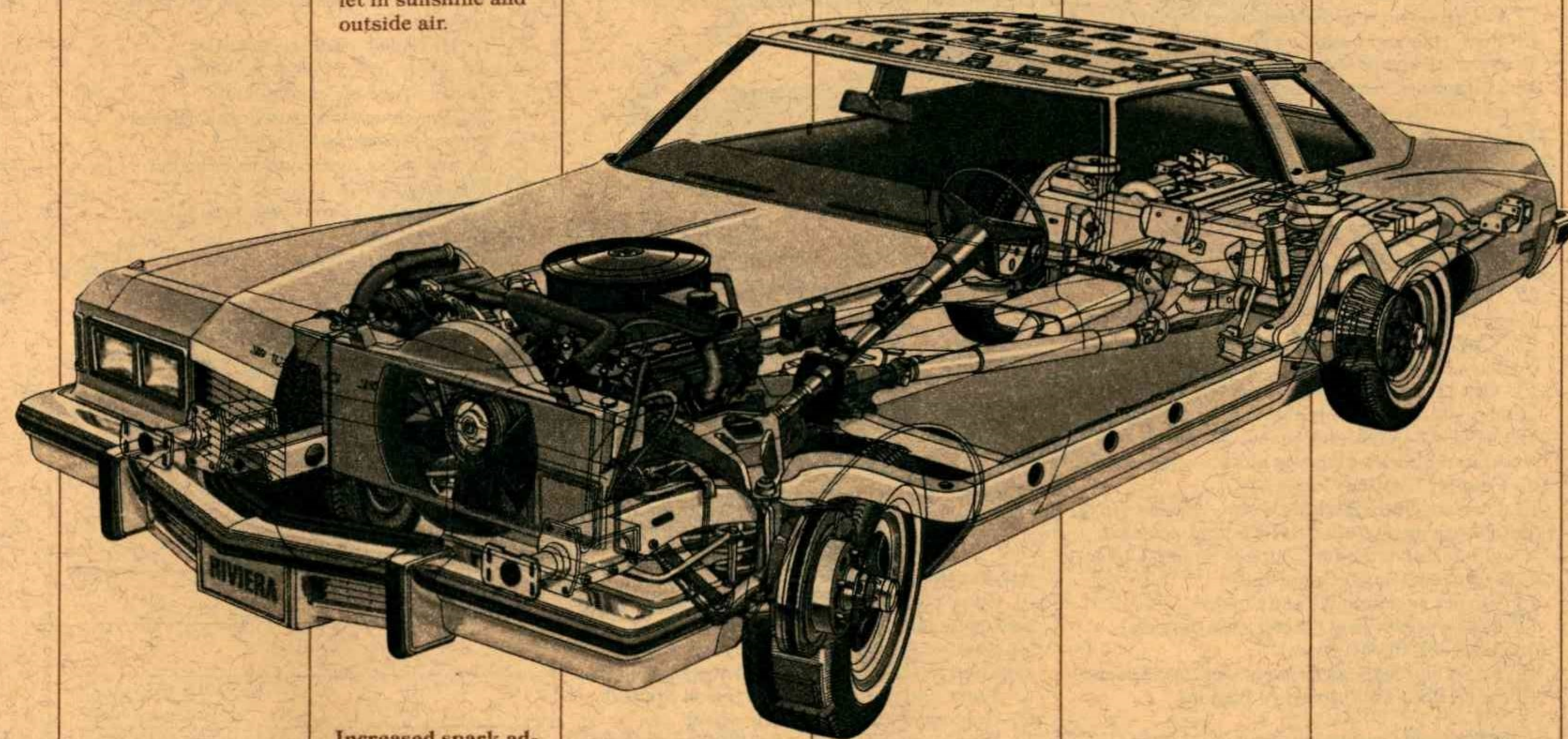

Sound deadening. High-density sound deadening material liberally applied throughout Riviera helps give the kind of interior quiet you would expect.

Increased spark advance on 7.5-litre V-8 engine improves gas mileage. With increased spark advance, fuel burns more completely, so you get the power you need out of the engine with less fuel.

Teflon coating inside shock absorbers helps reduce shock absorber wear and promotes smooth action on irregular road surfaces.

Power front disc brakes are standard on Riviera.

Full-foam seat construction gives both firm support and comfort.

Economy-ratio 2.56:1 rear axle contributes to improved overall fuel economy.

AVAILABLE MODEL.

Riviera Coupe-4EZ87

STANDARD EQUIPMENT.

Engine

- 7.5-litre (455 C.I.D.), V-8
- High-Energy Ignition
- Semi-closed cooling system
- Catalytic converter

Chassis

- Turbo Hydra-matic automatic transmission
- Variable-ratio power steering
- Power brakes with front discs
- Steel-belted radial-ply JR78-15 tires

Interior

- Cloth notchback seat
- Full-foam seat construction
- Power windows
- Full-Flo ventilation
- Cut-pile carpeting—front and rear
- Electronic, quartz-controlled digital clock
- Tilt steering wheel (not available with air restraint system)

Appearance and Protection

- Strong, reinforced front and rear energy-absorbing bumpers
- Front bumper guards
- Bumper protective strips—front and rear
- Inside hood-lock release offers theft protection
- Custom steering wheel
- Deluxe wheelcovers

AVAILABLE EQUIPMENT.

Chassis

- Full-length operating console
- California assembly line emission testing (required in California)
- Steel-belted radial-ply whitewall tires
- Steel-belted radial-ply wide whitewall tires
- Positive-traction differential
- Firm ride and handling suspension—

includes heavy-duty springs, wheels, shock absorbers and larger dia. front stabilizer bar (recommended for trailer towing)

- Automatic level control
- Rallye ride and handling (heavy-duty springs and shocks and rear stabilizer)
- Heavy-duty engine and transmission cooling (heavy-duty radiator, heavy-duty Delcotron, and thermal control fan)
- 80-amp. Delcotron
- Engine block heater
- 4-note horn
- Heavy-duty air cleaner
- Chrome-plated air cleaner
- Freedom battery (maintenance free)
- Heavy-duty wheels
- Trailer tow flasher and harness (5 wire)
- Trailer tow flasher and harness (7 wire)

Interior

- Leather 60/40 notchback seat, cloth 60/40 notchback seat, vinyl 60/40 notchback seat, vinyl 40/40 seats or cloth 40/40 seats in Riviera S/R
- 6-way power seat (bench seat, or driver side only with 60/40 and 40/40 seats)
- 6-way power seat (driver and passenger sides with 60/40 and 40/40 seats)

Comfort and Convenience

- AM radio
- AM radio and stereo tape player with front and rear dual speakers
- AM-FM stereo radio and stereo tape player with front and rear dual speakers
- AM-FM stereo radio with front and rear dual speakers
- AM-FM radio
- Rear seat speaker
- Automatic power antenna
- Front & rear dual speakers
- Fuel usage gauge
- Cornering lights
- Speed alert and trip odometer
- 3-speed windshield wiper with low-speed delay feature
- Soft-Ray tinted glass
- "Headlamps on" indicator
- Electric rear window defogger
- Rear window defogger (blower)
- Remote-control outside rear view mirror—right side
- Outside rear-view sport mirror

- Left remote mirror with outside thermometer
- Litter pocket
- Door courtesy and warning light
- Dome reading light
- Climate-Control air conditioner
- Automatic Climate-Control air conditioner
- Front and rear light monitors
- Cruise-Master speed control
- Tilt and telescoping steering column
- Electric trunk release
- Electric door locks
- Electric door and seatback locks
- Automatic electric door locks
- "Low fuel" indicator
- Sunshade map light
- Lighted visor vanity mirror
- Sunroof—electric operation
- Silver Astrorooft (sliding)
- Gold Astrorooft (sliding)
- Shadowlight Astrorooft (sliding)
- Rose Astrorooft (sliding)

Appearance and Protection

- Color coordinated custom front & rear seat belts (3 each) and front shoulder belts (2)
- Air-restraint system
- Bumper guards (rear only) (req. in Maryland, California and Florida)
- Door guards
- Chrome-plated wheels
- Super-deluxe wheel covers
- Deluxe wire wheel covers
- Styled wheel covers
- Protective body side moldings (front fender and body side)
- Riviera two-tone treatment:
 - Continental blue with silver
 - Judicial black with silver
 - Independence red with silver
 - Pewter gray with dark gray
- Trunk trim carpeting
- Blue body side stripe
- White body side stripe
- Gold body side stripe
- Black body side stripe
- Red body side stripe
- Long vinyl top
- Padded landau top
- Thickly-padded landau top and roof crown molding

YOUR ORDERING GUIDE. 1976 RIVIERA.

Be sure to consider: (mark your choices).

- Automatic Climate Control air conditioner
- 6-way power seat
- Tilt and telescoping steering wheel
- Astrorooft-glass sunroof
- Automatic level control
- Landau vinyl top with roof crown molding
- Positive-traction differential
- Firm ride and handling suspension
- AM radio with front and rear dual speakers
- AM-FM stereo radio with front and rear dual speakers
- AM-FM radio

Write in additional selections here:

The 1976 LeSabre: an inspection.

A new camshaft on LeSabre's standard 5.7-litre V-8 contributes to improved fuel economy this year.

Variable-delay windshield wipers are available on LeSabre. For light rain conditions, which don't require constant wiping, you can set the variable cycle control to wipe intermittently up to once every 15 seconds.

Inside hood-lock release helps prevent entry into LeSabre's engine compartment from the outside.

Full-foam seat construction gives both firm support and comfort.

Sound deadening. High-density sound deadening material is liberally applied throughout LeSabre, giving the kind of interior quiet you'd expect in a fine car.

LeSabre's paint. There are five layers of coating applied to LeSabre's exterior. One primer coat, one sealer and three coats of high-luster acrylic lacquer.

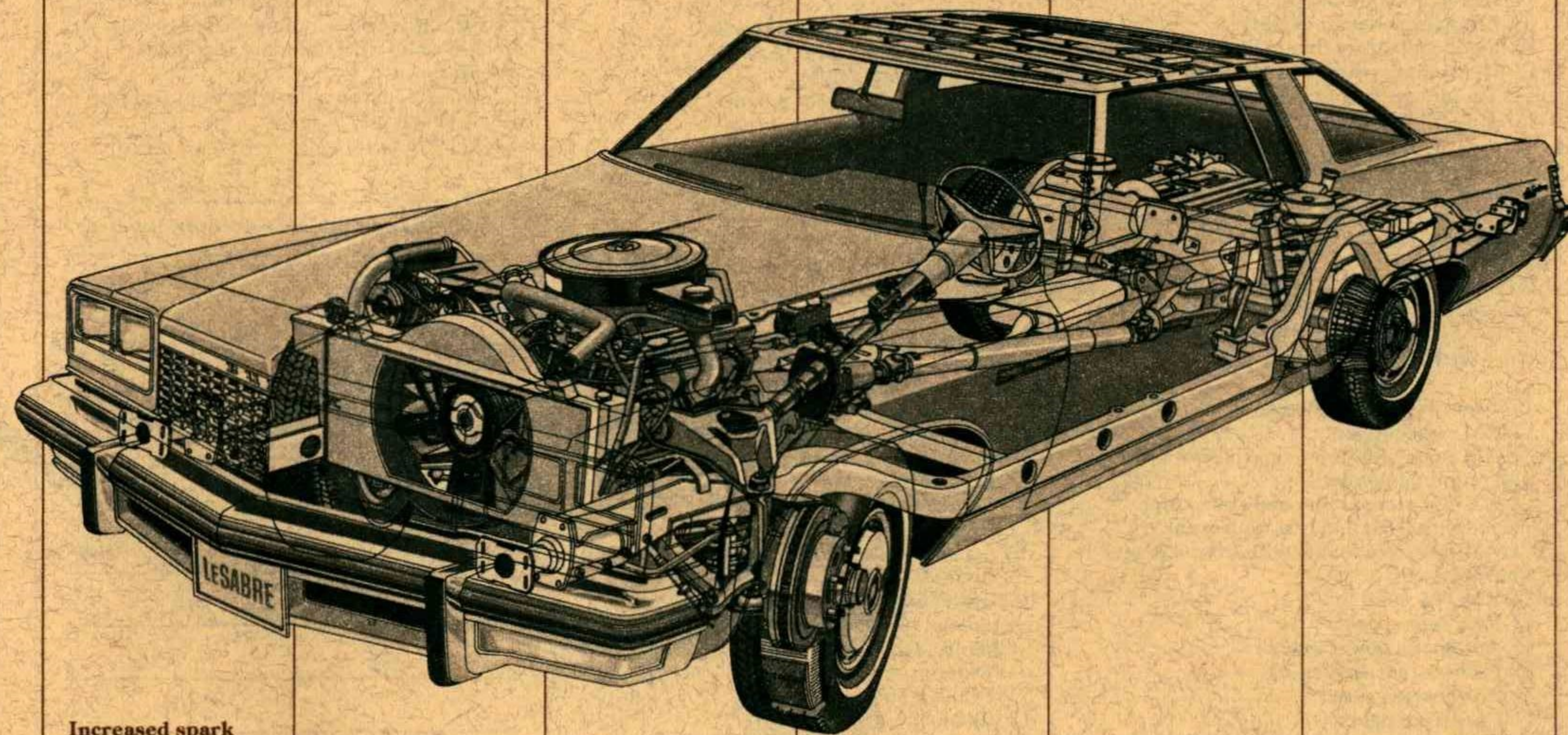

Increased spark advance on 5.7- and 7.5-litre V-8 engines improves gas mileage. With increased spark advance, fuel burns more completely so you get the power you need out of the engine from less fuel.

High-Energy Ignition eliminates need for points and ignition condenser and contributes to extended spark plug change interval. Up to 22,500 miles.

Brake proportioning valve varies front and rear braking forces, depending upon brake pedal effort, contributing to smooth stops.

Power front disc brakes. Standard on LeSabre.

Teflon coating inside shock absorbers helps reduce friction and wear and promotes smooth action on irregular road surfaces.

Economy 2.56 rear axle ratio contributes to improved overall fuel economy.

DIMENSIONS.

Dimensions (inches, unless otherwise noted)	LeSabre Custom Hardtop Coupe	LeSabre Custom Hardtop Sedan	LeSabre Custom 4-door Sedan
Wheelbase	124.0	124.0	124.0
Tread, front	63.4	63.4	63.4
Tread, rear	64.0	64.0	64.0
Length	226.8	226.8	226.8
Width	79.9	79.9	79.9
Height	53.2	53.3	54.0
Head room, front	38.1	38.4	38.9
Head room, rear	36.5	37.4	38.0
Leg room, front	42.1	42.1	42.1
Leg room, rear	35.8	38.8	38.8
Shoulder room, front	63.9	63.9	63.9
Shoulder room, rear	62.9	63.0	63.0
Hip room, front	59.4	59.4	59.4
Hip room, rear	56.0	59.6	59.6
Trunk capacity (cu. ft.)	17.5	16.8	16.8

MODEL AVAILABILITY.

LeSabre Custom —Coupe —4BP57
—Sedan —4BP69
—Hardtop Sedan—4BP89

STANDARD EQUIPMENT.

Engine

- 5.7-litre (350 C.I.D.), 4bbl. V-8
- High-Energy Ignition
- Semi-closed cooling system
- Catalytic converter

Chassis

- Turbo Hydra-matic automatic transmission
- Variable-ratio power steering
- Power brakes with front discs
- Steel-belted radial-ply HR78-15 tires (5.7-litre engine)
- Steel-belted radial-ply JR78-15 tires (7.5-litre engine)

Interior

- Choice of cloth notchback or vinyl notchback seats
- Full-foam seat construction
- Full-Flo ventilation
- Cut-pile carpeting—front and rear

Appearance and Protection

- Strong, reinforced front and rear energy-absorbing bumpers
- Bumper protective strips—front and rear
- Inside hood-lock release offers theft protection
- Deluxe wheelcovers

AVAILABLE EQUIPMENT.

Engine

- 7.5-litre (455 C.I.D.), 4bbl. V-8 engine

Chassis

- Steel-belted radial-ply whitewall tires
- Positive-traction differential
- Firm ride and handling suspension—includes heavy-duty springs, shock absorbers, wheels and larger dia. front

stabilizer bar (recommended for trailer towing)

- California assembly line emission testing (required in California)
- Heavy-duty engine and transmission cooling (heavy-duty radiator, heavy-duty Delcotron, thermal control fan, and fuel return lines on 350 C.I.D engine)
- 80-amp. Delcotron
- Engine block heater
- 4-note horn
- Heavy-duty air cleaner
- Heavy-duty battery
- Freedom battery (maintenance free)
- Heavy-duty wheels
- Trailer tow flasher and harness (5 wire)
- Trailer tow flasher and harness (7 wire)
- Automatic level control

Interior

- Cloth 60/40 notchback seat or vinyl 60/40 notchback seat
- Carpet savers and handy mats
- Front carpet savers
- Litter pocket
- 6-way power seat (on driver side only with 60/40 seats)
- 6-way power seat (on both driver and passenger sides with 60/40 seats)

Comfort and Convenience

- AM radio
- AM radio and stereo tape player with front and rear dual speakers
- AM-FM stereo radio and stereo tape player with front and rear dual speakers
- AM-FM stereo radio with front and rear dual speakers
- AM-FM radio
- Rear seat speaker
- Automatic power antenna
- Front and rear dual speakers
- Fuel usage gauge
- Climate-Control air conditioner
- Custom-Aire air conditioner
- Cornering lights
- Speed alert and trip odometer
- 3-speed windshield wiper with low-speed delay feature
- "Headlamps on" indicator
- Electric rear window defogger
- Rear window defogger (blower)
- Remote-control outside rear view mirror—left side

- Remote-control outside rear view mirror—right side
- Outside rear view sport mirrors (left and right)
- Left remote mirror with outside thermometer
- Door courtesy and warning light
- Dome reading light
- Power windows
- Front light monitors
- Cruise-Master speed control
- Tilt steering wheel
- Tilt & telescoping steering column
- Electric trunk release
- Electric door locks
- Electric door & seat back locks
- "Low fuel" indicator
- Accessory group—Sunshade map light, trunk light, courtesy light, electric digital clock (sunshade map light not included when right-hand remote-control mirror is ordered)
- Lighted visor vanity mirror
- Soft-Ray tinted glass
- Soft-Ray tinted windshield

Appearance and Protection

- Color coordinated custom front and rear seat belts (3 each) and front shoulder belts (2)
- Door guards
- Chrome-plated wheels
- Deluxe wire wheel covers
- Styled wheel covers
- Protective body side molding (front fender and body side)
- Custom window frame halo moldings
- Wide rocker appearance moldings
- Trunk trim covering (floor covering and side walls)
- Custom steering wheel
- Custom belt reveal molding
- Long vinyl top
- Landau top
- White body side stripe
- Gold body side stripe
- Black body side stripe
- Front & rear bumper guards

YOUR ORDERING GUIDE. 1976 LeSABRE CUSTOM.

Model selected:

Be sure to consider: (mark your choices).

- 7.5-litre V-8 with Turbo Hydra-matic
- Custom-Aire air conditioner
- Tilt and telescoping steering wheel
- 6-way power seat
- Power windows
- Freedom battery (maintenance free)
- Positive-traction differential
- AM radio
- AM radio and stereo tape player with front and rear dual speakers
- AM-FM stereo radio with front and rear dual speakers
- AM-FM radio

Write in additional selections here:

N.A.—Not available

The 1976 Electra: an inspection.

Sound deadening material around fender and shroud helps keep outside road noise from coming inside.

Astrorooft with roll-away shade. Available on Electra Coupes, it's actually three roofs in one. Closed, it's a regular roof. By sliding the inner shade back, you expose the tinted glass roof that lets in sunlight. Retract the glass roof, and you let in sunshine and outside air.

Variable-delay windshield wipers are available on Electra. For light rain conditions, which don't require constant wiping, you can set the variable cycle control to wipe intermittently up to once every 15 seconds.

Electra economy improvements include: increased spark advance, lower (2.56:1) rear axle ratio, and redesigned quadra-jet carburetor.

Available automatic door locking system. Move transmission selector to Park and all doors automatically unlock. Move it from Park and they lock automatically.

Four-link rear suspension for a smooth, quiet ride.

DIMENSIONS.

Dimensions (inches, unless otherwise noted)	Electra 225/Limited Hardtop Coupes	Electra 225/Limited Hardtop Sedans
Wheelbase	127.0	127.0
Tread, front	63.4	63.4
Tread, rear	64.0	64.0
Length	233.3	233.3
Width	79.9	79.9
Height	54.0	54.5
Head room, front	38.8	39.3
Head room, rear	38.1	38.2
Leg room, front	42.2	42.2
Leg room, rear	40.0	40.8
Shoulder room, front	64.0	64.0
Shoulder room, rear	63.4	63.1
Hip room, front	57.5	57.5
Hip room, rear	56.0	57.7
Trunk capacity (cu. ft.)	20.7	20.3

Altitude compensator on Turbo Hydra-matic transmission provides smooth, consistent shifting in varying altitudes. Which means your Electra shifts as smoothly in Denver as it does in Death Valley.

Teflon coating inside shock absorbers helps reduce shock absorber wear and promotes smooth action on irregular road surfaces.

High-Energy Ignition eliminates need for points and ignition condenser and contributes to extended spark plug change interval. Up to 22,500 miles.

Vapor return system routes unused fuel from fuel pump back to fuel tank via a vapor return line, thereby reducing the possibility of vapor lock.

A vibrating quartz crystal helps keep Electra's digital timepiece extremely accurate.

Rubber seals on ball joint assemblies protect bearing surfaces and help prevent dirt and moisture from entering ball joint.

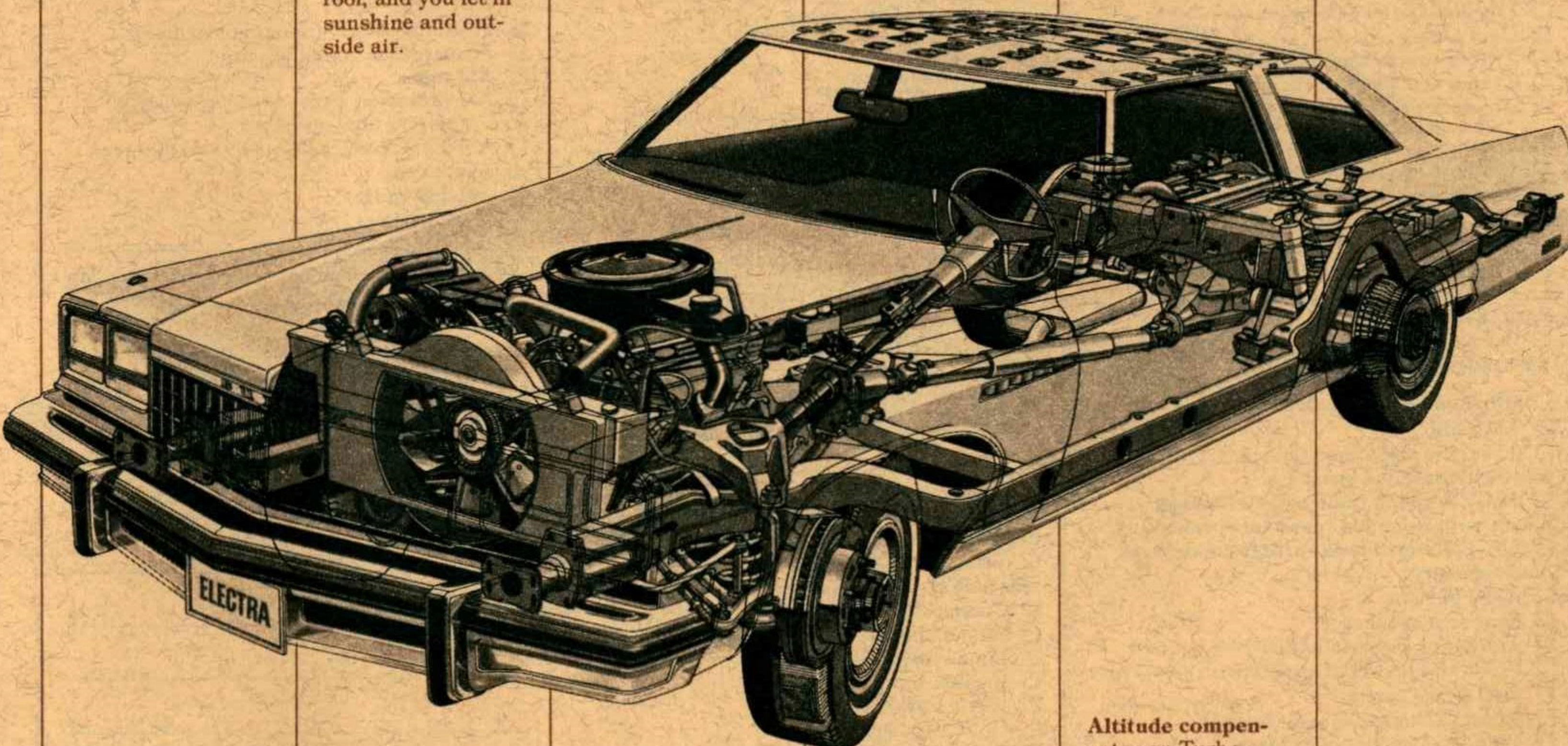

MODEL AVAILABILITY.

- Electra 225 — Coupe-4CV37
— Hardtop Sedan-4CV39
- Electra Limited — Coupe-4CX37
— Hardtop Sedan-4CX39
- Electra Park Avenue — Hardtop Sedan-Option

STANDARD EQUIPMENT.

Engine

- 7.5-litre (455 C.I.D.), V-8
- High-Energy Ignition
- Semi-closed cooling system
- Catalytic converter

Chassis

- Turbo Hydra-matic automatic transmission
- Variable-ratio power steering
- Power brakes with front discs
- Steel-belted radial-ply JR78-15 tires

Interior

- Choice of cloth bench or notchback seats, or vinyl notchback seat in Electra 225 Sedan
- Choice of cloth or vinyl notchback seat in Electra 225 Coupe
- Cloth 60/40 notchback seat in Limited models
- 2-way power seat in Limited
- Full-foam seat construction
- Fold-down center armrest for front seat
- Cut-pile carpeting—front and rear
- Power windows
- Full-Flo ventilation
- Dome reading lamp in Limited Sedan
- Custom seat and shoulder belts—color coordinated

Appearance and Protection

- Strong, reinforced front and rear energy absorbing bumpers
- Bumper protective strips—front and rear
- Wide rocker appearance moldings on Limited
- Inside hood-lock release offers theft protection

AVAILABLE EQUIPMENT

Chassis

- Steel-belted radial-ply whitewall tires
- Steel-belted radial-ply wide whitewall tires
- Positive-traction differential
- Firm ride and handling suspension—includes heavy-duty shock absorbers, springs, wheels and larger dia. front stabilizer bar (recommended for trailer towing)
- Automatic level control
- Heavy-duty engine and transmission cooling (heavy-duty radiator, heavy-duty Delcotron, and thermal control fan)
- Engine block heater
- 4-note horn
- Heavy-duty air cleaner
- 80-amp. Delcotron
- Trailer tow flasher and harness (5 or 7 wire)
- California assembly line emission testing (required in California)
- Freedom battery (maintenance free)

Interior

- Cloth 60/40 notchback seat or vinyl 60/40 notchback seat in Electra 225
- Leather 60/40 notchback seat in Electra Limited
- Cloth 40/40 seats or 60/40 seat in Limited Park Avenue
- Carpet savers and handy mats
- Front carpet savers
- Litter pocket
- 6-way power seat (bench seat, or driver side only with 60/40 or 40/40 seats)
- 6-way power seats (driver and passenger sides with 60/40 or 40/40 seats)

Comfort and Convenience

- AM radio
- AM radio and stereo tape player with front and rear dual speakers
- AM-FM stereo radio and stereo tape player with front and rear dual speakers
- AM-FM stereo radio with front and rear dual speakers
- AM-FM radio
- Rear seat speaker
- Automatic power antenna
- Front & rear dual speakers
- Fuel-usage gauge

- Automatic Climate Control air conditioner
- Climate Control air conditioner
- Cornering lights
- Speed alert and trip odometer
- 3-speed windshield wiper with low-speed delay
- "Headlamps on" indicator
- Electric rear window defogger
- Rear window defogger (blower)
- Remote-control outside rear view mirror—right side
- Left remote mirror with outside thermometer
- Door courtesy & warning light
- Dome reading light
- Front & rear light monitors
- Cruise-Master speed control
- Tilt steering wheel
- Tilt and telescoping steering column
- Electric trunk release
- Electric door locks
- Electric door and seat back locks
- Automatic electric door locks
- "Low fuel" indicator
- Sunshade map light
- Lighted visor vanity mirror
- Sun roof—electric operation
- Silver, gold, shadow light or rose Astrorooft (sliding)
- Soft-Ray tinted glass

Appearance and Protection

- Air restraint system
- Door guards
- Chrome-plated wheels
- Deluxe wire wheel covers
- Styled wheel covers
- Protective body side moldings
- Custom body side moldings
- Wide-rocker appearance moldings
- Trunk trim carpeting
- Coach stripe—gold, black or white
- Bumper guards (front & rear)
- Bumper system for Maryland, California & Florida
- Long vinyl top
- Thickly-padded landau top
- Long thickly-padded vinyl top
- Halo thickly-padded vinyl top
- Short landau top

YOUR ORDERING GUIDE. 1976 ELECTRA.

Model selected:

Be sure to consider: (mark your choices).

- Automatic Climate Control
- Astrorooft-glass sun roof
- Electric rear window defogger
- Cruise-Master speed control
- Cornering lights
- 3-speed windshield wiper with variable delay
- Firm ride and handling suspension
- AM-FM stereo radio with front and rear dual speakers
- AM-FM radio

Write in additional selections here:

The 1976 Estate Wagon: an inspection.

MODEL AVAILABILITY.

Estate Wagon
 -2-seat Station Wagon-4BR35
 -3-seat Station Wagon-4BR45

STANDARD EQUIPMENT.

Engine

- 7.5-litre (455 C.I.D.), V-8
- High Energy Ignition
- Semi-closed cooling system
- Catalytic converter

Chassis

- Turbo Hydra-matic automatic transmission
- Variable-ratio power steering
- Power brakes with front discs
- Steel-belted radial-ply LR78-15 tires
- Heavy-duty wheels

Interior

- Vinyl bench seat
- Full-Flo ventilation
- Cut-pile carpeting—front and rear
- Full-foam seat construction
- Power tailgate window
- Hidden storage compartment
- Glide-away tailgate
- Forward-facing third seat and divided second seat (3-seat model)

Appearance and Protection

- Deluxe wheel covers
- Strong, reinforced front and rear energy-absorbing bumpers
- Bumper protective strips—front and rear
- Inside hood-lock release offers theft protection

AVAILABLE EQUIPMENT

Chassis

- Steel-belted radial-ply whitewall tires
- Positive-traction differential
- Firm ride and handling suspension—includes heavy-duty shock absorbers, springs and larger dia. front stabilizer bar (recommended for trailer towing)
- Automatic level control
- California assembly line emission testing

(required in California)

- Heavy-duty engine and transmission cooling (heavy-duty radiator, heavy-duty Delcotron, and thermal control fan)
- 80-amp Delcotron
- Engine block heater
- Heavy-duty air cleaner
- Freedom battery (maintenance free)
- Trailer-tow flasher and harness (5 or 7 wire)

Interior

- Cloth notchback seat
- Cloth 60/40 notchback seat
- Vinyl notchback seat
- Vinyl 60/40 notchback seat
- Custom seat and shoulder belts—color coordinated
- Carpet savers and handy mats
- Litter pocket
- 6-way power seat (bench seat or driver side only on 60/40 seats)
- Load floor area carpet

Comfort and Convenience

- AM radio
- AM radio and stereo tape player with front and rear dual speakers
- AM-FM stereo radio and stereo tape player with front and rear dual speakers
- AM-FM stereo radio with front and rear dual speakers
- Rear seat speaker (single)
- Automatic power antenna
- Fuel usage gauge
- Climate-Control air conditioner
- Custom-Aire air conditioner
- Cornering lights
- Speed alert and trip odometer
- 3-speed windshield wiper with low-speed delay feature
- Electric rear window defogger
- Door courtesy & warning light
- Dome reading light
- Power windows
- Power tailgate door
- Luggage rack
- Luggage locker with lock
- Remote-control outside rear view mirror—left side
- Remote-control outside rear view mirror—right side
- Left remote mirror with outside thermometer

- Cruise-Master speed control
- Tilt steering wheel
- Tilt and telescoping steering column
- Electric door locks
- "Low fuel" indicator
- Accessory group—Digital clock, sunshade, map light, license plate frame and rear door jamb switch
- Lighted visor vanity mirror
- Soft-Ray tinted glass
- Front light monitors

Appearance and Protection

- "Headlamps on" indicator
- Chrome-plated wheels
- Styled wheels or wire wheel covers
- Protective body side molding (front fender and body side)
- Custom rocker panel, rear quarter lower, front and rear wheel opening and front fender lower molding
- Wood-grain vinyl applique (wide rocker panel, tailgate, wheel opening and front & rear quarter lower moldings)
- Tailgate moldings
- Bumper guards (front and rear)
- Door guards
- Vinyl top

DIMENSIONS.

Dimensions (inches, unless otherwise noted)	Estate Wagon 2-seat	Estate Wagon 3-seat
Wheelbase	127.0	127.0
Tread, front	63.4	63.4
Tread, rear	64.0	64.0
Length	231.8	231.8
Width	79.9	79.9
Height	57.8	57.0
Head room, front	39.6	39.6
Head room, rear	39.3	39.4
Leg room, front	42.1	42.1
Leg room, rear	39.4	37.4
Shoulder room, front	64.0	64.0
Shoulder room, rear	63.1	63.1
Hip room, front	59.4	59.4
Hip room, rear	59.0	59.0
Cargo Volume (cu. ft.)	105.7	105.7

YOUR ORDERING GUIDE. 1976 ESTATE WAGON.

Model selected:

Be sure to consider: (mark your choices).

- Automatic level control
- Heavy-duty cooling
- Positive-traction differential
- Firm ride and handling suspension
- Custom-Aire air conditioner
- Remote tailgate door
- Cruise-Master speed control
- Power windows
- Tinted glass
- Luggage rack
- Electric door locks
- AM radio and stereo tape player with front and rear dual speakers
- AM-FM stereo radio with front and rear dual speakers
- AM-FM radio

Write in additional selections here:

1976 Buick safety features.

OCCUPANT PROTECTION

Seat belts with pushbutton buckles for all passenger positions

Two front combination seat and inertia reel shoulder belts for driver and right front passenger (with reminder light and buzzer)

Energy absorbing steering column

Passenger guard door locks

Safety door latches and hinges

Folding seat back latches

Energy absorbing padded instrument panel and front seat back tops (Including intermediate seat back tops on three-seat station wagons)

Contoured windshield header

Thick laminate windshield

Safety armrests

Safety steering wheel

Cargo Guard (except Hatchbacks and Station Wagons)

Contoured roof inner panel

Glove box and console door latch impact security

Smooth contoured door and window regulator handles

Soft, low profile window control knobs, coat hooks, dome lamp

Automatic locking front and rear outboard seat belt retractors

Shoulder belt anchorages for rear seat outboard occupants

Pressure lock radiator cap

High strength front seat anchorages and construction

High strength rear seat retention

Stamped steel door hinges

Air Cushion Restraint System for front seat occupants available at extra cost on Buick Riviera, Electra and LeSabre.

ACCIDENT PREVENTION

Side marker lights and reflectors

Parking lamps that illuminate with headlamps

Four way hazard warning flasher

Backup lights

Lane change feature in direction signal control

Windshield defrosters, washer and dual speed wipers

Wide view inside mirror (vinyl edged, shatter resistant glass and deflecting support)

Outside rear view mirror

Dual master cylinder brake system with warning light

Starter Safety Switch

Dual action safety hood latches (front opening hoods)

Headlamp aiming access provision

Low glare instrument panel top, inside windshield mouldings, wiper arms and blades, and steering wheel metallic surfaces

Safety wheel rims

Uniform shift quadrant

No-winged wheel nuts, discs and caps

Front disc brakes with audible wear indicators

Self-adjusting brakes

Illumination of windshield wiper and washer, heater and defroster controls

Pressure relief gas cap

ANTI-THEFT

Anti-theft ignition key reminder buzzer

Anti-theft steering column lock

Anti-theft key system (one key for ignition only, other key for glove compartment, doors, trunk and tailgate)

Visible vehicle identification

Tamper resistant odometer with telltale feature

Buick. Dedicated to the Free Spirit in just about everyone.



All illustrations and specifications contained in this catalog are based on the latest product information available at time of publication approval. The right is reserved to make changes at any time, without notice, in prices, colors, materials,

equipment, specifications and models, and to discontinue models. Some of the equipment shown or described throughout this catalog is available at extra cost. Check with your Buick dealer for complete information.

