

The new Škoda Felicia.

The change goes on.



GLXi Hatch



GLXi Estate



Volkswagen Group

We've changed the company. We've changed the car.

"The Felicia shines with its new-found quality feel."

What Car? August 1995

"Škoda has come of age - this car puts its recent past behind it. The Felicia earns our Honour for Best Budget Car of the year."

Auto Express - 28/7/95

"The interior is a revelation: squeak - free, with good switchgear, clear instruments, excellent seats, a nice driving position and loads of headroom."

Richard Simpson, The Guardian - 6/5/95

"The Felicia is tidily compact but still spacious, while you notice its superb build quality even before turning the key."

Auto Express - 28/7/95

"The Škoda Felicia . . . is a seriously good car."

Matthew Carter, The Mail on Sunday - 23/4/95

Why we had to change.

To understand the changes at Škoda, you have to know that for the first half of this century we were one of the world's greatest marques. We built Hispano-Suiza, one of the most elegant cars on the road. As early as 1905 our Laurin and Klement Type A was a huge success but the cold war stopped all that, and the years of isolation took their toll.

We had become too inward-looking, making the cars we wanted to make, rather than the cars most customers wanted. Sure, our cars were tough and rugged, with a rally history of being out in front, time after time. In the Acropolis Rally and the Monte Carlo Rally, we'd won our class every year for almost a quarter of a century. Right up to 1994 when a Škoda won the FIA World Championship.

But our cars never had a "fashionable" image. Conclusion: we had to change.

Volkswagen invested a huge amount of cash and expertise.

With their input, we revolutionised

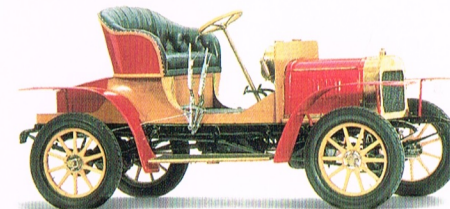

our quality control systems. Totally revised our design processes. Everything was scrutinised, everything. Thanks to them, we've changed even the way we think.

The future's already here.

We've turned the company around. In fact at Škoda over the past four years, we've managed to change more than any car maker in the world.

The results are there for all to see in the new generation of Škoda cars. First, with 1995's launch of the Škoda Felicia Hatch. And now, today, with the brand new Škoda Felicia Estate.

We're going to keep on changing at Škoda. Changing to meet your needs, and the needs of your family. We're going to continue combining Volkswagen design and engineering skills with Škoda's toughness and rugged build quality.

Because we know that when a car company changes, it can only be judged by the cars which are actually produced. The Felicia 1.3 Hatch and the new Estate are evidence of that change.



Volkswagen Group

Changing up.

Introducing the 1.3 Hatch and the new Škoda Felicia Estate.

This new Škoda generation of cars doesn't look the way most people expect a Škoda to look. They don't feel the way most people expect a Škoda to feel. And they don't drive the way you'd expect a Škoda to drive. In short, these are some of the finest cars we've ever made. We've gone for a look and styling which is definitely European in character, but with the unique individuality you look for in a car today. The front end is wedge shaped, with round-edged headlamps and integrated indicators. The flush mounted, large-size



bumpers can absorb an impact of up to 3mph and spring right back. And when it comes to performance, the 1.3 litre engine gives you the performance you want in a Hatch today - with all the convenience that five doors can truly afford. The new generation of Škodas are robust in every detail. Just what you'd expect from the tough, rugged engineering quality which is Škoda and Volkswagen together. But it's really only when you get inside that you can appreciate what's so different about the new Škoda range...



Volkswagen Group



LXi Plus Estate (Roof rails will become available as a dealer fitted option on this model)



GLXi Hatch (alloy wheels are a dealer fitted option.)

Enjoy the change.

Sit down in one of the new Škodas and the first thing you'll notice is a changed level of comfort. The ergonomically designed seat will keep you as happy on a long motorway journey, as on a short trip to the shops. Also, there's a look and feel about the interior which you'd simply never expect from a Škoda. From the attractive design of the upholstery, to the pleasing clunk of the door closing. Those important first impressions are impressive indeed.

Once you start to look around the inside, you'll find there's an unusually generous amount of room available. Tall drivers in particular will notice increased headroom and legroom - and more shoulder space too. Best of all, the interior design of the Hatch ensures there's a surprisingly

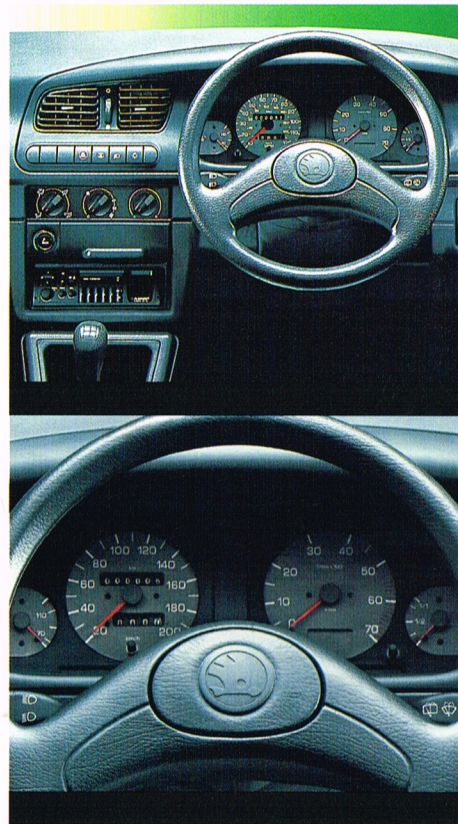

spacious fit for five people in a car of its size. As for the Estate, the interior space available has to be seen to be believed.

Padded doors increase the feeling of comfort.

When it comes to actually enjoying the drive, feedback from the latest ergonomic research has been used to position the controls and to design the instrument panel to be virtually reflection-free. You'll recognise everything at a glance.

The newly developed heating and ventilation system is an important contribution to your driving pleasure, allowing you to change the interior climate rapidly to suit your needs. It's all done to enable you to relax and simply enjoy driving the new Škoda.



More than you'd ever expect from Škoda.

A higher level of engineering than ever before.

We know that car drivers are rightly becoming more and more demanding.

So we aim to provide engine technology that's a little ahead of its time.

Škoda and Volkswagen engineers have responded to the challenge with transverse engines, made of aluminium to save on weight. These engines are approximately 25% lighter than a conventional car engine with the same capacity, they conduct heat better, take less time to warm up and consequently use less fuel.

We've also specified a Bosch Monomotronic injection system. Intelligent enough to improve consumption figures and provide cleaner exhaust emissions at the same time. A three-way catalytic converter is now fitted as standard and reduces exhaust pollution by up to 90%.

Our engines already meet the new European Commission Stage II emission regulations which will not come into force until 1996.



Monomotronic. This intelligent injection system cuts down on fuel consumption and provides cleaner exhaust emissions.



The regulated three-way catalytic converter with lambda probe reduces emissions, in particular carbon monoxide and nitrogen oxides.

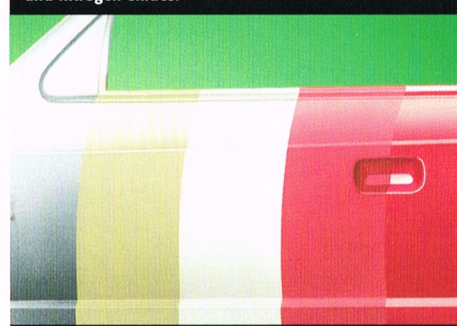

Long life guaranteed: doors, bonnet, and other vulnerable components are galvanised to protect against corrosion.

Revolutionised standards of quality.

To guarantee quality standards, we make sure that the entire car undergoes rigorous testing, by Škoda and Volkswagen engineers working together.

This means over half a million test miles from the Arctic circle to Africa over mud and gravel tracks, months of corrosion tests, and the most punishing durability trials imaginable. Including sixty long days in a punishing heat and humidity chamber at 50°C and at an air humidity of 90%.

Doors and wings have been galvanised, bodywork is protected with a multi-coat paint process, and wax injected into body cavities to give it the best guard against corrosion.

Thanks to these steps, we can confidently offer a six year anti-perforation warranty.

No annual bodywork inspections are necessary.

On the Hydropulse device, the car undergoes a gruelling series of test cycles which simulate driving conditions on the roughest roads. Škoda and Volkswagen engineers can gather valuable data about driving performance and the strength of the bodywork.

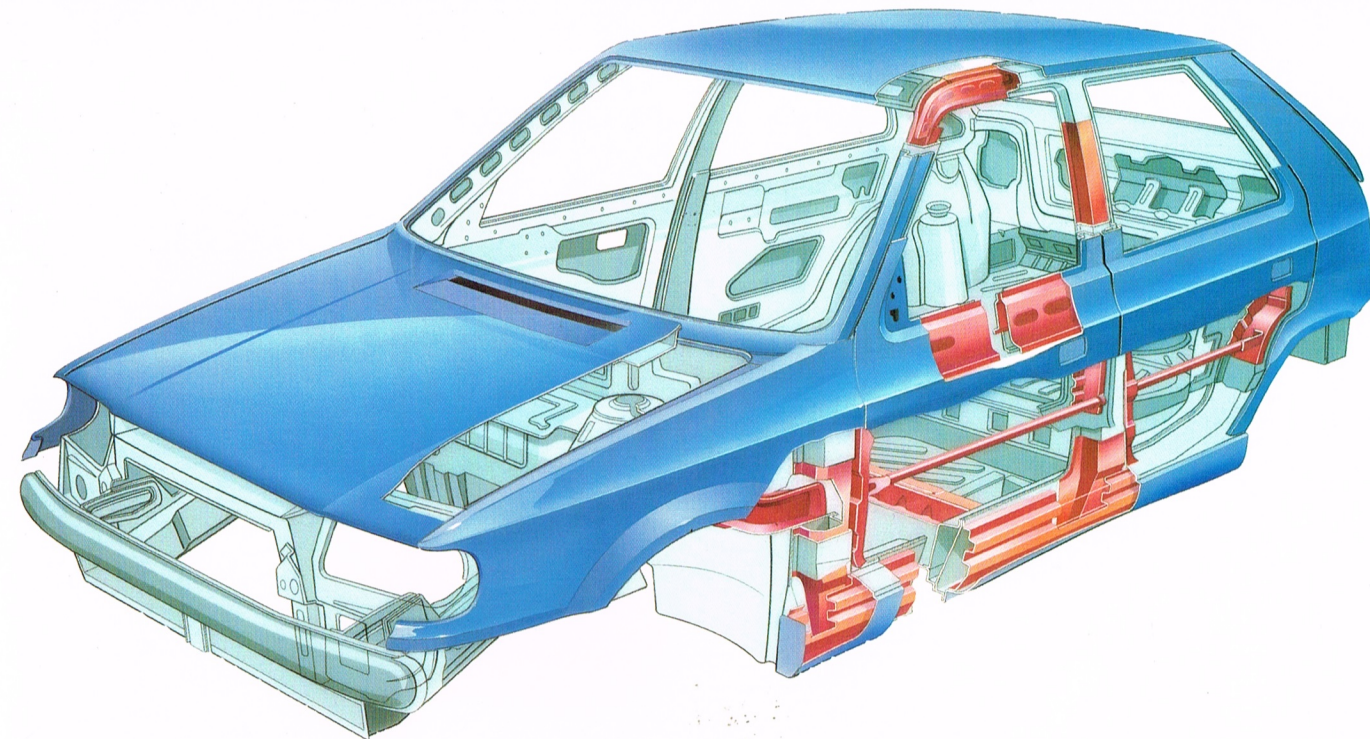

A new door design minimises the damage in the event of impact from the side.



The 1.3 litre fuel injected engine is designed for excellent all-round performance and long life, available in 54 bhp (Hatch) and 68 bhp (Hatch and Estate) versions.

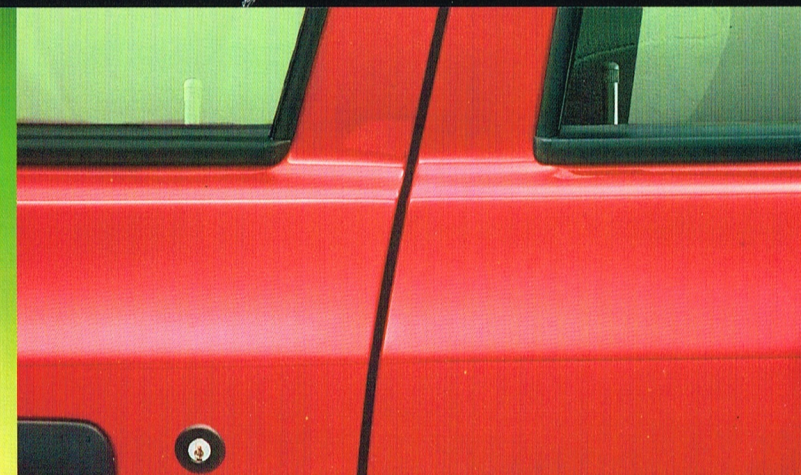

All design elements are checked in accordance with strict quality guidelines. Improved tolerances between panels help reduce wind noise.

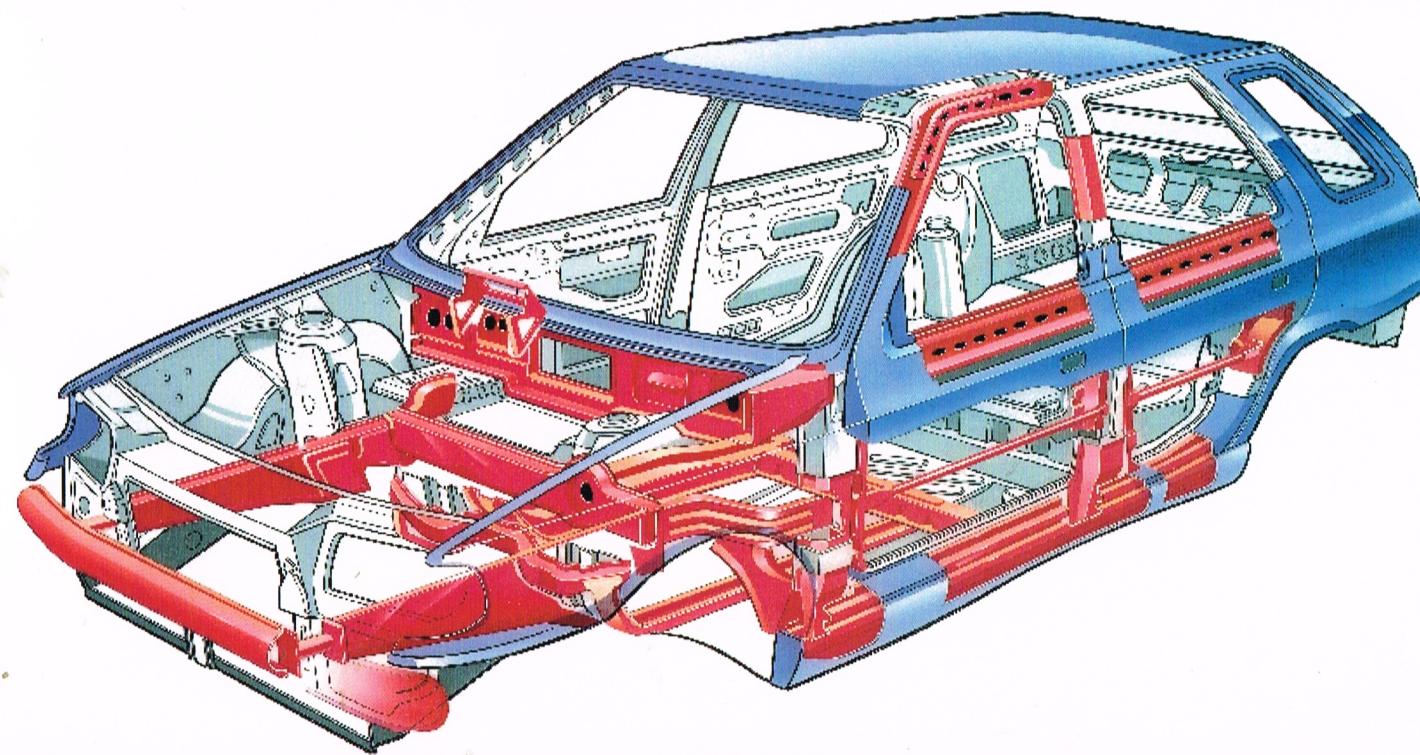

Front and rear crumple zones are built into the car, surrounding a computer-designed passenger safety cell.

More space.

The new generation of Škoda has been designed with space in mind. More car for your money is no idle boast - experience the roomy interiors for yourself and you'll agree. And when you open the boot you couldn't fail to be impressed.

Doors are wide-angle in their design, and tailgates too. These are built to lift high, so bumping your head is less likely.

When you're carrying five passengers in the Estate, there's still an impressive 15.6 cu.ft. of boot space. Fold down the rear seat and before you know it there's an astonishing



47.8 cu.ft. to play with. You can also remove the rear seat which will then give you an incredible 51.6 cu ft of available space.

We maximised the size of the boot opening too, to make sure that life's easier when you're loading anything. And we didn't stop there. We've designed in some options knowing that all those things you'll want to carry, for business or pleasure are unlikely to come in standard shapes and sizes.

The sill is placed low, to make sliding anything in much more straightforward. And if you've got something really unwieldy to carry, you can fold the rear seat two thirds, or one third split.

That should see you sailing off with everything from stepladders to skis.



GLXi Estate (Roof rails will become available as a dealer fitted option on this model).



More safety.

Safety in the new Škoda has been very carefully considered - both from the point of view of protecting the occupants of the car, and also to actively contribute to the safety of other road users.

With this in mind, all potential impact surfaces are large and rounded, with wipers, door handles and mirrors designed to be recessive in the event of a collision.

On the inside, there's the all-important passenger safety cell. Height-adjustable seat belts. And unusually for cars in this class, head restraints fitted as standard both front and rear.

The less obvious safety details haven't been neglected either. Impact from the side is now the second most common form of car accident. So the insides of the doors have been strengthened with a thickened steel bar, and the whole door design changed to help deflect side-impact collision energy away from the car occupants.



Head restraints are fitted as standard both front and rear.



The safety steering column deflects crash energy away to the side to minimise danger.

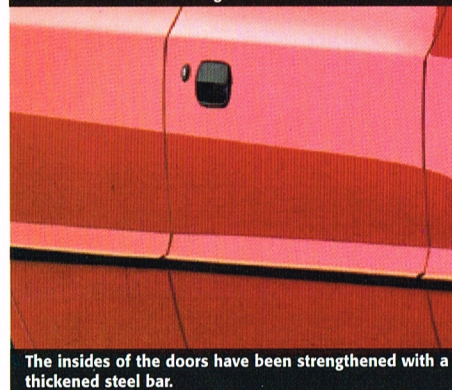

The insides of the doors have been strengthened with a thickened steel bar.

In the event of a head-on crash, or the all-too-common impact from the rear, front and rear deformation zones have been built in. The steering wheel and column are designed to buckle under stress. The steering wheel itself is both large and padded with a recessed boss to help minimise impact damage.

The underlying safety principle is to provide this new generation of Škoda cars with a "hard" passenger cell surrounded by skilfully-engineered "softer" zones to absorb collision energy.

With all these safety features built in, the sheer value for money the new Škoda represents is nothing short of amazing.

Yet that's what you can expect from the combination of Volkswagen's standards of quality, and Škoda's tradition for value.

With every one of our new Škodas, all the new European standards for safety have been passed with ease.



Volkswagen Group

More attractive features.

Now that you know a little more about the enormous changes which have been happening at Škoda, you can see what it means in real terms. Clearly, to say that the new Škodas offer good value for money would be something of an understatement. Especially as we've made sure that you get an extensive range of features built in as standard.



The Boston, Verona and Montreux radios from Blaupunkt ensure optimum sound quality. Check with your dealer which radio is fitted as standard (if applicable) to the Škoda of your choice. All radios include a roof aerial with built-in amplifier.



Ask your Škoda dealer about giving your Škoda that special sporty flair. Choose from several types and styles of alloy wheels.



Volkswagen Group

We don't want you to have to ask for those things which we all now regard as essential.

But everyone likes to customise their own car to an extent - perhaps just to add a little individual touch of personality.

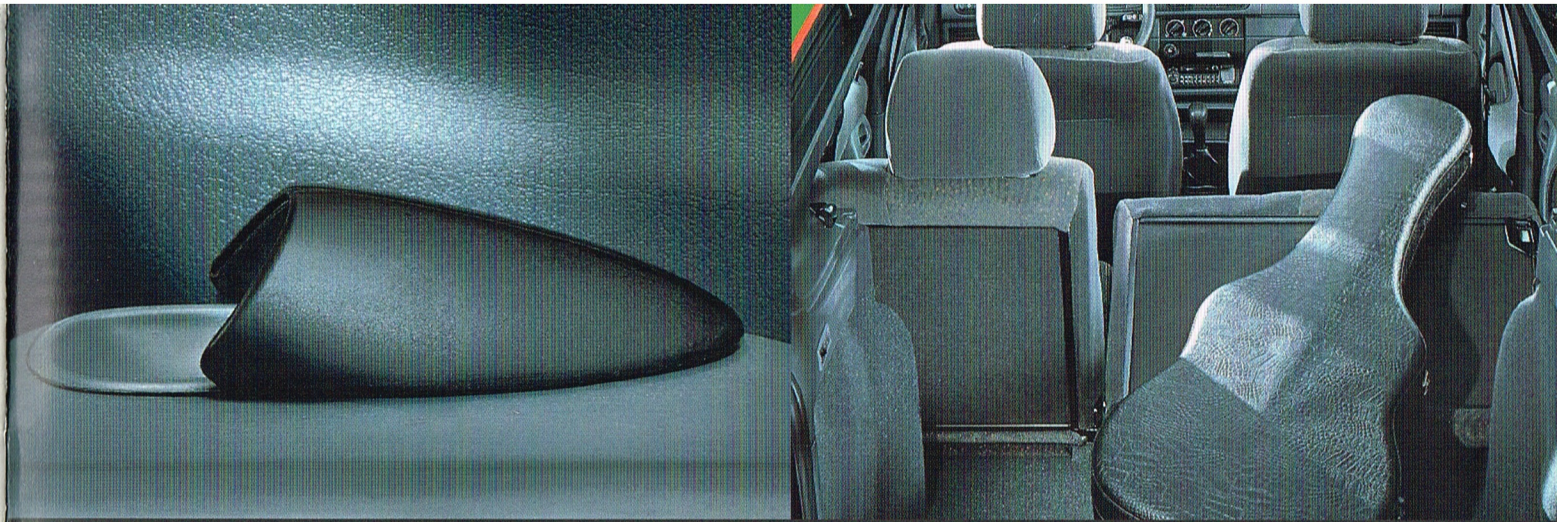

REAR HATCH REMOTE CONTROL

The remote boot release makes the Felicia even more convenient. Standard fitting on both LXi Plus and GLXi models.

PARTITIONED REAR SEAT

The rear seat is split two thirds/one third, so you can change the size of the load space just as you please. Standard fitting on the LXi Plus and GLXi Hatch and Estate.



TINTED WINDOWS

Cool in summer and good-looking all the year round. Standard fitting on GLXi Hatch and Estate.

CENTRAL LOCKING SYSTEM

The Škoda Felicia can be fitted with a central locking system. Quick and convenient. Standard fitting on GLXi Hatch and Estate.



SUNROOF

With the new detachable flap-back sunroof, the Felicia is even greater fun to drive in the summer. Standard fitting on GLXi Hatch and Estate. Dealer fitted option on other models.

FOGLAMPS

Fog lamps are standard on the GLXi Hatch and Estate. Also available as dealer fitted option on all other models.

Better designed, all round.

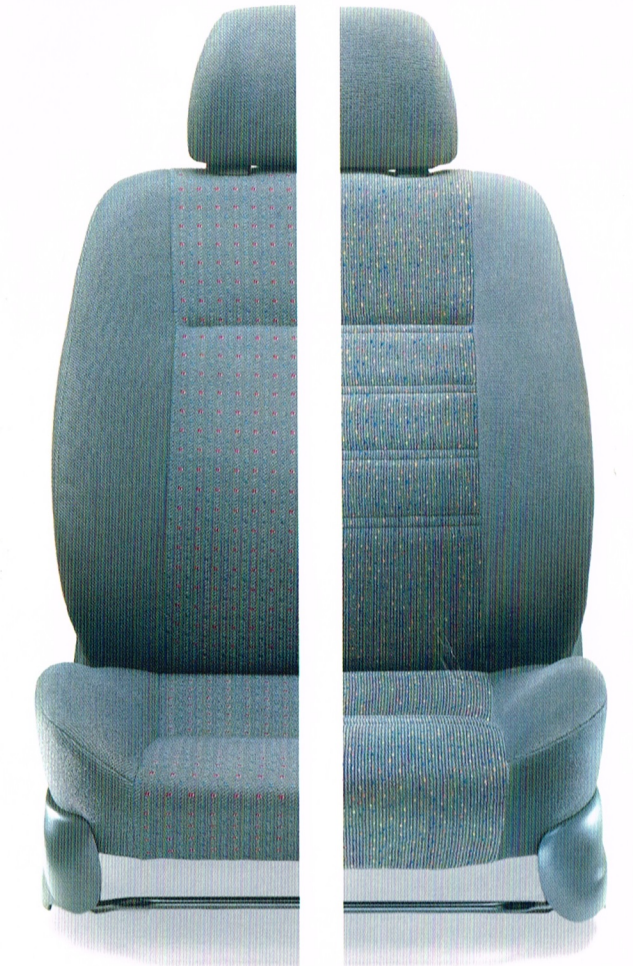

It wasn't enough for us to give you a radically changed look on the outside of the new Škodas. We were determined that our new levels of quality should be clearly on display on the inside, too.

Every detail has been carefully considered.

It took us three years to develop the seats alone. Tests prove they provide excellent support even on the longest journey.

And the fabric in the seat covers doesn't just look good - it's designed to take rough treatment as well as "breathe" for your personal comfort.

We wanted this change, in particular, to be as good as the rest.

Change, beautiful change.



ice blue metallic - 94 51

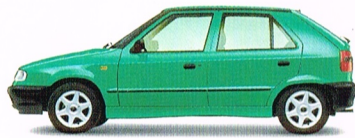

atlantic green - 52 60



arctic blue - 46 20



dark green metallic - 95 90



royal blue - 47 10



pearl white - 10 88



romantic red - 82 90



silver metallic - 91 03



purple metallic - 98 80



brilliant black - 19 99

The new Škodas are available in ten different colours

And thanks to Volkswagen's technical know-how, the standard of finish provides beauty which is more than skin deep.

Whatever colour you choose, a series of exhaustive checking procedures makes sure the final coat is free from defects - including an examination under light eight times brighter than sunlight.

Škoda has never ever looked so good. And that's a change you'll love.



Volkswagen Group

Even more reason to change.

One thing we won't be changing is an excellent dealer network. There are more than 230 Škoda dealers throughout the UK, so there's bound to be one near you. Which means faster service when you need it, help and advice whenever it's called for, including ready stocks of spare parts, and a guarantee to provide absolutely any part normally within just 24 hours.

2 year unlimited mileage warranty.

The new Škoda Felicia is covered by a full two year warranty, regardless of mileage, against defects in material or manufacture. The paintwork is also covered by this warranty, and the bodywork has a full 6 year anti-perforation warranty with no annual inspection charges.

2 year AA membership.

In addition to your Škoda Felicia warranty there is a special two year Assistance programme which you can access through a dedicated Freephone number. This includes Roadside Assistance, Home Start Relay Recovery and Relay Plus.

A Special and Exclusive Insurance Package.

Škoda Felicia owners can obtain motor insurance at attractive rates from the Volkswagen Insurance Company (GB) Ltd., a company which has been specialising in UK motor insurance for over 30 years.

The service includes a 24-Hour Accident Helpline, financial help with legal representation and a free recovery service for uninsured losses.

No other insurance scheme guarantees to have your Škoda repaired to the manufacturers standard. Check our Quotations Hotline on 0345 616161, or ask your Škoda dealer for details.

Attractive ways to finance your purchase.

Volkswagen Financial Services has an enormous amount of experience in helping people buy cars in the UK.

We can now put this at your disposal when buying a Škoda, and help you find just the right financial package to suit your monthly budget. Simply ask your Škoda dealer which package is right for you.

Škoda Solutions.

Driving a new Škoda has never been easier. From the outset, the amount you pay per month, the level of initial deposit, and even the Final Payment (Guaranteed Minimum Value) - which can help protect you against future car resale risks - can be decided by you at the start of the contract. Flexibility and peace of mind is at the heart of Škoda Solutions. You decide the model which meets your needs, and choose your ideal 'tailored package'. Ask your local Škoda dealer for details.

Škoda Solutions - The new way to drive a Škoda.

Škoda Mobility

People in receipt of the Higher Mobility Component of the Disability Living Allowance receive special help from Škoda. Preferential prices or low cost contract hire is available through your local approved Mobility Dealer. For full details contact your local dealer.

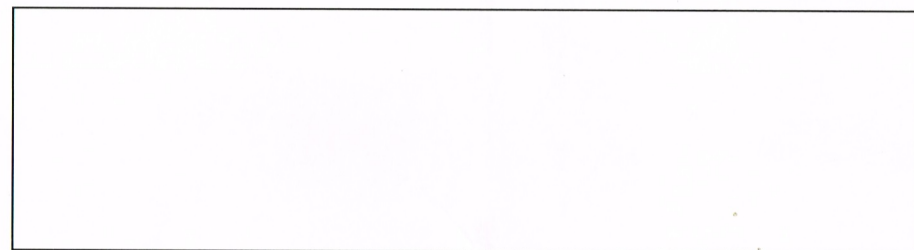

Volkswagen Group

We've changed the car. Can you change your mind?

Škoda UK, Garamonde Drive, Great Monks Street, Wymbush, Milton Keynes MK8 8NZ.

Telephone 0345 745745

For further information and the location of your local Škoda dealer.