

Ford trucks

DA.2418—114 W.B.ARTIC

D.1618—Rigid

Max. GVW's 28,000 lb. 29,120 lb. 32,000 lb.

Max. GCW 54,000 lb. 60,000 lb.(114" W.B. only)

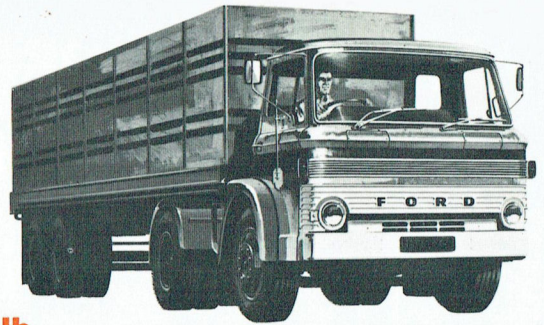

This model previously called D1000

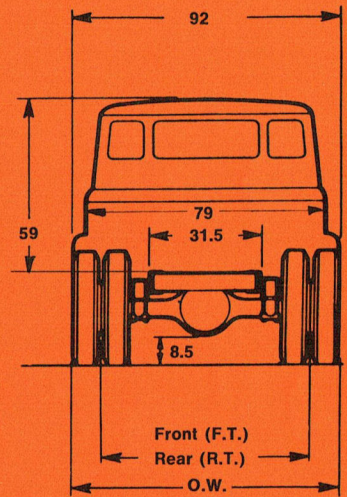
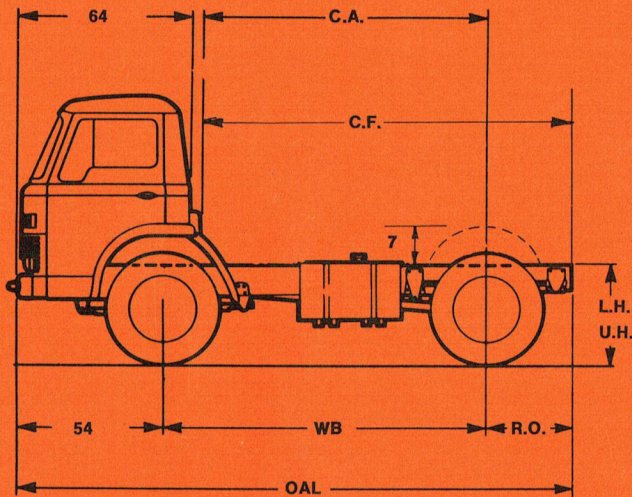

All measurements above are in inches.

WB (in)	OAL (in)	C.A. (in)	R.O. (in)	O.A. (in)	C.F. (in)	U.H. (in)	L.H. (in)	R.T. (in)	O.W. (in)
114	198	102	30	102	132	37.5	34.5	69	93
179	290	167	57	167	224	38	35.5	70	92
226	356	214	76	216	294	38	35.5	70	92

GVW (lb)	WHEELBASE (in)	APPROXIMATE KERB WEIGHT			APPROXIMATE AVAILABLE FOR PAYLOAD, EQUIPMENT, ETC.		NOMINAL PAYLOAD
		FRONT	REAR	TOTAL			
28,000	114*	6145 lb.	4020 lb.	10,165 lb.	17,835 lb.		7½ tons
29,120	114*	6425 lb.	4005 lb.	10,430 lb.	18,691 lb.		7½ tons
32,000	114*	6450 lb.	4045 lb.	10,495 lb.	21,505 lb.		9 tons
29,120	179	6346 lb.	3764 lb.	10,110 lb.	19,010 lb.		7½ tons
32,000	179	6366 lb.	3804 lb.	10,170 lb.	21,830 lb.		8½ tons
29,120	226	6566 lb.	3970 lb.	13,536 lb.	18,584 lb.		7 tons
32,000	226	6586 lb.	4016 lb.	10,602 lb.	21,398 lb.		8 tons

*Add 55 lb. to front & 50 lb. to rear for RT610 Transmission.

Specifications

Max. GVW's 28,000 lb. 29,120 lb. 32,000 lb.

Max. GCW 54,000 lb. 60,000 lb. (114" W.B. only)

	(114" WB)	(179" WB)	(226" WB)
Min. recommended body length	11'0"	16'6"	20'0"
Nom. recommended body length	11'0"	18'6"	24'0"
Max. legal body length	14'0"	21'6"	25'6"
Max. O/A length — legal	19'4"	26'6"	31'0"
Engine: Diesel. Make — Cummins. Displacement (C.I.D.) — 470. Compression ratio — 18:1. Max. gross B.H.P./R.P.M. — 185/3300. Max. nett B.H.P./R.P.M. — 176/3300. Max. gross torque lb.ft./r.p.m. — 328/1900. Max. nett torque lb.ft./r.p.m. — 323/1900. R.A.C. horsepower — 68. Bore and stroke — 4.62" x 3.5".			
Engine Specifications: Cylinder block — Alloy cast iron. Cylinder head — Alloy cast iron. Camshaft — Alloy steel. Main bearings — 5 replaceable insert. Pistons — Alum. alloy. Valves: intake — Stainless steel. Valves: exhaust — Stainless steel.			
Cooling System: Pressurized. Capacity — 64.5 pts. Fan: no. blades/dia. — 6, 21".			
Fuel System: Carburettor — Fuel pump — Pressure time control. Fuel pump drive — Gear. Firing order — 1 5 4 8 6 3 7 2.			
Lubricating System: Oil filter — Full flow replaceable element. Oil pump — Gear 65 p.s.i. Oil refill capacity — 20 pints.			
Electrical System: Type — 24V. Injector pump — Cummins. Starter motor — Axial type ign. key op. Alternator — 30A. Battery — 2 No. 120A — 15 plate. Injectors — PT-B.			
Engine Equipment: Air cleaner — 10" cyclopak. Air intake — Stackpipe.			
Clutch: Type — Twin disc dry plate. Size: dia. — 12"; area — 252 sq. ins.			
Driveline: Universal joint size — Hardy Spicer 1600.			
Transmission:			
Type	Turner T5C 4007 (54000 G.C.W.)	Fuller RT610 (60000 G.C.W.)	
Ratios — 1st	6.75	1st 9.0 6th 2.62	
2nd	3.24	2nd 7.02 7th 2.05	
3rd	1.81	3rd 5.48 8th 1.6	
4th	1.182	4th 4.26 9th 1.24	
5th	1.0	5th 3.43 direct 1.0	
Rev.	6.63	Rev. 2.7 & 9.5	
Both boxes Synchronised — all gears except 1st. Power take-off opening T5C and RT610 — L/R.H.S. No. 6 S.A.E.			
Front Axle: Type — Ford Solid I-Beam. Capacity — 10640 lb. (114" WB.). Track 74.5". 15700 lb. (all other WB.). Track — 75.5".			
Rear Axle: Type — Eaton 18220. Capacity — 22500 lb. Ring gear dia. — 16.5". Ratio — 6.5/8.87 (7.17/9.75 option) - (7.17 — 60,000 G.C.W.) Track — 69.12" (Narrow Track) (W/10640 FA), 70.12" (W/15700 FA) (Wide Track).			
Frame:			
	114" W.B.	179"/226" W.B.	
Yield point — p.s.i.	51,500	51,000	
Section modulus	14.18	15.12	
Depth — ins.	10.63	12.0	
Steering: Type — Worm and peg (power assisted on 15700 FA).			
Ratio	28:1		
Steering wheel dia.	19.81"		
	114" WB.	179" WB.	226" WB.
Turning circle: outside of tyre	39'0"	56'5"	69'5"
wall to wall	43'5"	61'0"	74'0"
Brake System: Type Dual full air			
Size — front	15.5 x 6.0 (15700 F/A)	6.0 (15700 F/A)	
rear	15.5 x 7.0 (wide track)	7.0 (wide track)	
Area	667 sq. ins.	788 sq. ins.	
Parking brake — type	Mech. power assisted		
area	325 sq. ins.	425 sq. ins.	
Suspension:			
Front springs	12 leaf		
Pad capacity	4500 lb. (10640 F/A), 6200 lb. (15700 F/A)		
Rear springs	12 leaf		
Pad capacity	8000 lb. (114 WB.), 9000 lb. (179 WB.), 11000 lb. (226 WB.)		
Auxiliary	4 leaf		
Pad capacity	1810 lb. (114-179 WB.)		
Shock Absorbers: Double acting telescopic at front.			
Wheels:			
Size — type — no. studs	114" WB. B6: 5 x 20-10	179"/226" WB. B7: 5 x 20-10	
Bolt circle dia.		13.189"	
Offset		5.75"	
Tyres:			
Size — front std.	(28000 G.V.W.) 9.00 x 20-12	(29120 G.V.W.) 10.00 x 20-12	(32000 G.V.W.) 11.00 x 20-12
rear std.	9.00 x 20-12	10.00 x 20-12	11.00 x 20-12
Fuel Tank: Capacity — 90 galls. 114" WB. (45 galls. 179"-226" WB.).			
Spare Wheel Carrier: Locn. — winch type, near side (179 & 226 wheel bases only)			
Instruments: Shrouded bezel contains printed circuit instrument cluster of speedometer — odometer — fuel — temperature gauges — low air warning buzzer — beam — direction — ignition — oil pressure — low air pressure — hand brake engagement warning lights. Tachometer — oil pressure and battery condition gauges also standard.			
Lighting: Sealed beam headlights — front parking/clearance lamps — two-way front turn indicators — composite tail/turn indicator/stop/number plate lamps — cab courtesy light and instrument illumination.			
Features: Custom tilt cab includes — washable roof and rear wall lining — rubber floor mat and insulation pad — full width padded dual sun visors and dash panel — two coat hooks — lockable glove compartment — chromed door pulls — chromed grab handles — heater/demister and lockable opening quarter vents — fully adjustable driver's seat and two-place passenger seat — dash mounted hand brake — dual electric horns — front towing eyes — chromed windshield surround — front bumper bar and cab trim strip — west coast rear vision mirrors — trailer brake coupling — driver's lap seat belt and all lap/sash seat belt anchorages — self-parking dull surfaced windshield wipers — zone toughened one-piece curved windshield (laminated glass option) — external door locks and push-button handles both sides — tail light stone guard and number plate bracket — stowage pockets within doors — battery cover.			
Colours: Red, grey, green and white.			
Options: Fuller RT610 Transmission (114" WB. only)			

The specifications referred to above were in effect at the time this publication was approved for printing; however, Ford Motor Company of Australia Limited and/or Ford Sales Company of Australia Limited reserve the right, subject to the laws of any state or territory and the regulations of any

competent authority which may be applicable at the time, at its discretion and without notice, to change specifications and prices of the products referred to herein at any time and without incurring any liability whatsoever to any purchaser thereof.

FORD SALES COMPANY OF AUSTRALIA LIMITED Reg. Office: 1735 Sydney Road, Campbellfield, Vic.

