

Ford Cortina.

The lively medium
for today's way of driving.

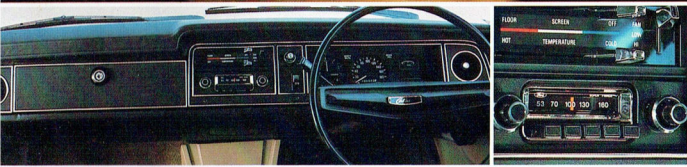



'76 Cortina-more features, better value-for-money.

Cortina is getting better all the time. With sporty blackout grille and co-ordinated interior colour schemes. The economy Cortina L and the superbly appointed Cortina XL now have more legroom for rear seat passengers than before. Even the luxurious Cortina XLE has been improved!

Cortina can be whatever you make it. With a thrifty 2 litre four, or smooth 3.3 and 4.1 litre six cylinder engines. With sporty 4 on the floor manual or convenient T-Bar automatic transmission. What's more, you have the convenience of national Ford Dealer back-up service.

Cortina XL. True car comfort in a size for today.

If you can't afford to buy big,

yet you can't shoehorn your family into something small... Cortina XL is your logical choice! Cortina XL's high level of standard equipment has made it the most popular Cortina. There's carpets, reclining bucket seats, deluxe push-button radio, electric clock. Convenient steering column control stalks put turn indicators, lane change, high-low beam, head-light flasher, horn and windscreen wiper/washer action at your fingertips.

And for '76, Cortina XL has rectangular quartz halogen headlamps, radial ply tyres and electrically heated rear window. How's that for features?

Other Standard Equipment items are: 2 litre 4 cylinder overhead cam engine, 4 speed floor shift, front power disc brakes, inertia reel front seat belts, centre console with armrest, folding centre armrest in rear, full wheel covers.

Printed March 1976



Cortina L and XL Wagons.

The medium-sized Wagons that are big on features.

Cortina wagon is the most accommodating in its class. There's ample room for a family and almost 1 cubic metre of load space.

Fold the rear seat down and the load space increases to 1.8 cubic metres. For easy-opening convenience, Cortina wagon has a one-piece counter-balanced rear door.

Now, '76 Cortina Wagons look classier than ever. With sporty grille and co-ordinated interior colour combinations. '76 Cortina L and XL Wagons have quartz halogen headlamps. Inside, the 'L' model has bigger armrests and '76 Cortina XL Wagon has radial ply tyres, a rear window demister plus all the comfort and convenience features of the XL sedan!

Standard Equipment highlights common to L and XL Wagons:

2 litre overhead-cam four teamed with 4 on the floor transmission and power front disc brakes . . . front inertia reel seat belts . . . steering column stalk controls for turn indicators, lane change, high/low beam, headlight flasher, horn, 2-speed wind-screen wipers and washers . . . Contoured and reclining, high-backed front bucket seats . . . Carpeting Ventilation system with individual ball vent controls, separate foot level vents . . . 2 speed heater/demister . . . Cigarette lighter . . . Courtesy lights . . . Reversing lights . . . Right hand exterior rear vision mirror.

Additional XL Wagon highlights:

. . . Push button radio . . . electric lock . . . carpeted load space . . . rear window demister . . . radial ply tyres . . . styled wheel covers . . . console with storage bin and package tray between front seats . . . glove box light.

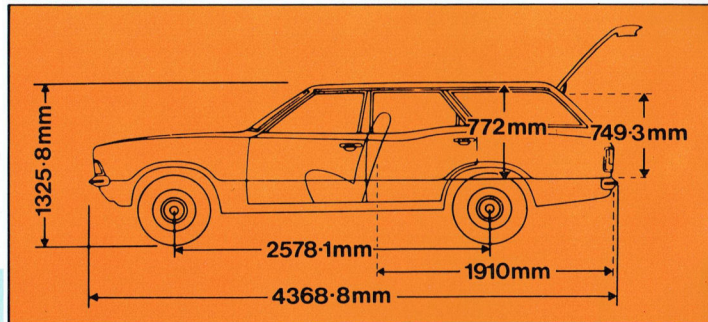
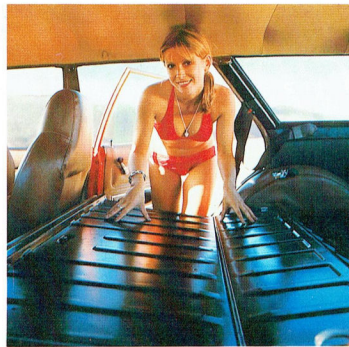

Printed March 1976



Cortina L.

A "Rallye" Pack turns it into a sporty-looking machine.

You'll have trouble convincing your friends that '76 Cortina L is the low-priced model. Look what you get — carpets, reclining bucket seats, European style steering column control stalks, power front disc brakes and the lusty 2 litre OHC four cylinder engine matched with a slick four speed floor shift. Of course, you can specify '76 Cortina L with either of the big sixes, and T-Bar automatic.

Cortina L is getting better all the time, too. For '76, there's rectangular quartz halogen headlamps, sporty blackout grille and colour keyed interior combinations. The optional "Rallye" pack comprises: 8 spoke sports road wheels, rocker panel blackouts, black door handles and bumpers, leather-bound steering wheel, tachometer, simulated leather

gear shift knob, quartz halogen driving lights.

Sports handling suspension is optional too. Of course, you can specify the "Rallye" pack with the '76 Cortina XL sedan and wagon too.

L Standard Equipment Highlights:
Contoured, cushioned high-backed reclining bucket seats . . . Carpeting . . . Rectangular quartz halogen headlights . . . Power front disc brakes . . . Steering column control stalks for turn indicators, lane change, high/low beam, headlight flasher, horn, 2-speed wipers and washers . . . Ventilation system with individual ball vents and separate foot level vents . . . Front inertia reel seatbelts . . . Interior courtesy lights operated by front doors . . . Cigarette lighter . . . Styled right hand exterior rear view mirror.

Illustrated right: Cortina L interior with optional T-bar automatic transmission (Available at extra cost).

Illustrated below: Cortina L with optional "Rallye" pack and 4.1 litre 6-cylinder engine (available at extra cost).

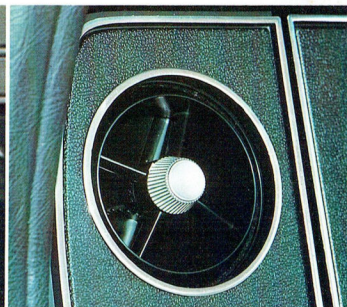

Cortina XLE.

Your own special world of luxury.

A car with as many standard features as Cortina XLE had seemed very hard to improve. But we did, for '76. Cortina XLE is getting better all the time.

The 2 litre OHC four cylinder engine is now optional at reduced cost. Similarly you can specify four on the floor manual gear at reduced cost, in lieu of the standard T-Bar automatic. '76 Cortina XLE includes cut-pile carpeting and keyed interior colour combinations. *XLE Standard Equipment Highlights:* 4.1 litre "six" . . . 3-speed, T-Bar Automatic transmission . . . Power assisted front disc brakes . . . Radial ply tyres . . . Deep-cushioned, high backed reclining bucket seats . . . Centre console with armrest, storage bin, electric clock . . . Push button radio . . . Special cloth and vinyl upholstery . . . Deep cut-pile

carpeting . . . "Woodgrain finish" instrument panel . . . Ventilation system with individual ball vent controls, separate foot level vents . . . Electrically heated rear window demister . . . Boot light, interior courtesy lights operated by all doors . . . tachometer, metric speedometer/odometer, trip meter, fuel, oil and temperature gauges . . . Quartz halogen headlights . . . Rubber bumper over riders front and rear . . . Rear seat map pockets . . . Vinyl roof . . . Steering column stalk controls, right hand for turn indicators, lane change, high/low beam, headlight flasher and horn, left hand for 2-speed windscreen wipers and 4 jet washers . . . Remote control right hand exterior mirror . . . Leather bound steering wheel . . . Seat belt warning light . . . Full length body side mouldings . . . XLE emblem on rear pillar . . . Cigarette lighter . . . Dual-tone horns.

Printed March 1976

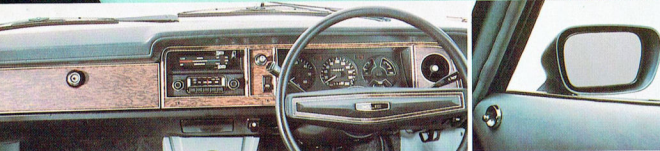

Engine and Transmission Availability

Combinations		L	XL	XLE
2.0 litre OHC 4 cylinder	All-synchro 4-speed manual	STD	STD	O/R
	T-bar automatic	OPT	OPT	O/R
3.3 litre (200 CID) 6 cylinder	All-synchro 3-speed manual	OPT	OPT	NA
	All-synchro 4-speed manual T-bar automatic	OPT	OPT	NA
4.1 litre (250 CID) 6 cylinder	All-synchro 3-speed manual	OPT	OPT	NA
	All-synchro 4-speed manual T-bar automatic	OPT	OPT	O/R STD

Engine Specifications

	2.0 litre	3.3 litre	4.1 litre
Displacement — cubic centimetres	1998 ³⁰	3280	4100
Bore/Stroke	96.4 mm (3.56") x 76.7 mm (3.02")	93.4 mm (3.68") x 79.5 mm (3.13")	93.4 mm (3.68") x 99.3 mm (3.91")
Compression ratio	9.2:1	9.1:1	9.3:1
Carburettion	2 barrel	Single	Single

Optional Equipment

	L		XL		XLE
	Sedan	Wagon	Sedan	Wagon	Sedan
1. "Rallye" Pack (a)	O	O	O	O	NA
2. Sports Road Wheels (mag type)	O	O	O	O	O
3. LH styled Exterior Mirror	O	O	O	O	O
4. Remote control ext. mirror (RH)	O	O	O	O	STD
5. Leather-bound sports steering wheel	O	O	O	O	STD
6. Tinted/laminated windscreen	O	O	O	O	O
7. Push-button radio	O	O	STD	STD	STD
8. Heated rear window demister	O	NA	STD	STD	STD
9. Sliding steel sunroof (b)	O	NA	O	NA	O
10. Styled full wheel covers	O	O	STD	STD	STD
11. Vinyl Roof — Black, Brown, Beige	O	NA	O	NA	STD
12. White painted roof	O	NA	O	NA	O
13. Cloth seat trim	NA	NA	O	NA	STD
14. Body protection group (c)	O	NA	O	NA	STD
15. 175 SR 13 Radial ply tyres (d)	O	O	STD	STD	STD
16. BR70 H13 Radial ply tyres	O	O	O	O	O

Code for above: O means optional at extra cost, STD means standard equipment, NA means not available, O/R means optional at reduced cost.

NOTE: (a) The "Rallye" Pack consists of special black paint treatment and decal, sports road wheels, LHS rear view mirror, driving lights, leather-bound sports steering wheel, tachometer and simulated gear shift knob. (b) A vinyl roof cannot be specified with a sliding sunroof. (c) Body protection group includes full length side protection strips, and front and rear bumper over-riders. (d) 175 SR 13 radial ply tyres are a mandatory option with 4.1 litre 6-cyl. engine.

FORD WARRANTY:

Subject to such other conditions, warranties and/or undertakings which may apply from time to time under the laws of Australia and/or any applicable State or Territory thereof, FORD'S WARRANTIES with respect to each new passenger or light commercial vehicle sold by Ford, that for a period of 12 months or 20,000 kilometres (whichever first occurs) from the date of original retail sale, FORD WILL repair or replace free of charge any part of such vehicle (except tyres) found to be defective in factory materials or workmanship under normal use and operation within Australia, PROVIDED THAT:—

- (i) the vehicle has been properly used, operated, maintained and cared for within the manufacturer's operation and capacity limitations, and
- (ii) the repair or replacement is carried out by an authorised Ford Dealer.

**"Ford" means, Ford Sales Company of Australia Limited.

PLEASE NOTE:

The illustrations, information and specifications presented and referred to herein were correct at the time when this publication was approved for printing; however, Ford Motor Company of Australia Limited and/or Ford Sales Company of Australia Limited reserve (or the right, subject to the laws of Australia and/or any applicable State or Territory thereof and/or the regulations of any competent authority which may apply from time to time, at their or its discretion, and without notice, to discontinue or change the specifications, design and prices of the products referred to herein and any options therefor at any time without incurring any liability whatsoever to any purchaser thereof.

Some of the items illustrated or referred to herein are optional at extra cost. Some options may be required in combination with other options. Always consult your Ford Dealer for the latest information on models, specifications, features, prices, options and availability.

FORD MOTOR COMPANY OF AUSTRALIA LIMITED
FORD SALES COMPANY OF AUSTRALIA LIMITED
1755 Sydney Road, Campbellfield, Victoria

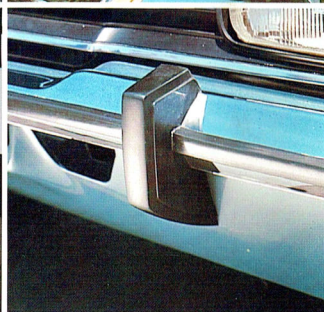
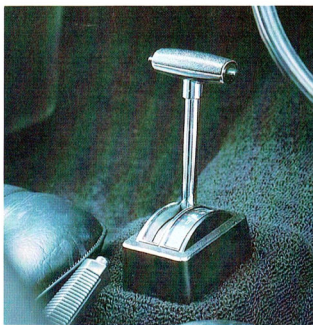

Extra cost options illustrated above: T-bar automatic transmission, sliding sunroof, sports road wheels and bumper over-riders.

Driver and passenger protection features:

"Safety" glass all round with zone toughened area in front of driver • Windscreen mounted, break-away anti-glare rear view mirror • Articulated windscreen wiper action for wide-screen wiping • Dual-line braking system with instrument warning light • "Friction-disc" steering column isolates road shock and collapses on reaching predetermined level of impact load • 2-speed windscreen wipers and washers with control stalk on steering column • High-intensity quartz halogen headlights • Wrap-around front turn indicator and parking lights • Power assisted front disc brakes incorporating strong disc pads • Radial ply tyres and rear window demister on XL and XLE models • "Safety-cage" passenger compartment — front and rear ends absorb impact shock progressively before it reaches the passenger compartment • Styled driver's side exterior rear view mirror • Double-lock door locks • "Child proof" locks on rear doors help prevent accidental opening • Reversing lights and wrap around tail, brake and turn indicators • Wide 5.0 x 13 inch "safety" rim wheels • Inertia reel front seat belts.

Dimensions/Capacities...

SEDANS:

Overall — length (a) 4260 mm (167.7")
width 1706 mm (67.1")
height (b) 1315 mm (51.8")
Wheelbase 2578 mm (101.5")
Track — front 1422 mm (56.0")
— rear 1422 mm (56.0")
Turning circle 9.7 m (31.8ft)
Ground clearance 147.3 mm (5.8")
Fuel Tank capacity 54 litres (12.0 gals)
Luggage capacity (c) .34 m³ (12.0 cu ft)

Note: All dimensions above, except (a) (b) and (c) are identical for sedans and wagons.

WAGONS:

Overall — length 4361 mm (171.6")
— height 1325 mm (52.2")
Load capacity
— to front seat .95 m³ (33.2 cu ft)
— to rear seat 1.81 m³ (63.8 cu ft)

Printed March 1976

FORD CORTINA





Cortina XLE. Your own special world of luxury.

A car with as many standard features as Cortina XLE had seemed very hard to improve. But we did, for '76 Cortina XLE is getting better all the time.

The 2 litre OHC four cylinder engine is now optional at reduced cost. Similarly you can specify four on the floor manual gear at reduced cost, in lieu of the standard T-Bar automatic. '76 Cortina XLE includes cut-pile carpeting and keyed interior colour combinations. **XLE Standard Equipment Highlights:** 4.1 litre "six" . . . 3-speed, T-Bar Automatic transmission . . . Power assisted front disc brakes . . . Radial ply tyres . . . Deep-cushioned, high backed reclining bucket seats . . . Centre console with armrest, storage bin, electric clock . . . Push button radio . . . Special cloth and vinyl upholstery . . . Deep cut-pile

carpeting . . . "Woodgrain finish" instrument panel . . . Ventilation system with individual ball vent controls, separate foot level vents . . . Electrically heated rear window demister . . . Boot light, interior courtesy lights operated by all doors . . . tachometer, metric speedometer/odometer, trip meter, fuel, oil and temperature gauges . . . Quartz halogen headlights . . . Rubber bumper over riders front and rear . . . Rear seat map pockets . . . Vinyl roof . . . Steering column stalk controls, right hand for turn indicators, lane change, high/low beam, headlight flasher and horn, left hand for 2-speed wipers and 4 jet washers . . . Remote control right hand exterior mirror . . . Leather bound steering wheel . . . Seat belt warning light . . . Full length body side mouldings . . . XLE emblem on rear pillar . . . Cigarette lighter . . . Dual-tone horns.

Printed March 1976



Engine and Transmission Availability

Combinations	L	XL	XLE	
2.0 litre OHC 4 cylinder	All-synchro 4-speed manual T-bar automatic	STD OPT	STD OPT	O/R O/R
3.3 litre (200 CID) 6 cylinder	All-synchro 3-speed manual All-synchro 4-speed manual T-bar automatic	OPT OPT OPT	OPT OPT OPT	NA NA NA
4.1 litre (250 CID) 6 cylinder	All-synchro 3-speed manual All-synchro 4-speed manual T-bar automatic	OPT OPT OPT	OPT OPT OPT	NA NA O/R

Engine Specifications

	2.0 litre	3.3 litre	4.1 litre
Displacement — cubic centimetres	1998	3280	4100
Bore/Stroke	96.4 mm (3.56") x 76.7 mm (3.02")	93.4 mm (3.68") x 79.5 mm (3.13")	93.4 mm (3.68") x 99.3 mm (3.91")
Compression ratio	9.2:1	9.1:1	9.3:1
Carburettion	2 barrel	Single	Single

Optional Equipment

	L		XL		XLE
	Sedan	Wagon	Sedan	Wagon	Sedan
1. "Rallye" Pack (a)	O	O	O	O	NA
2. Sports Road Wheels (mag type)	O	O	O	O	O
3. LH styled Exterior Mirror	O	O	O	O	O
4. Remote control ext. mirror (RH)	O	O	O	O	STD
5. Leather-bound sports steering wheel	O	O	O	O	STD
6. Tinted/laminated windscreen	O	O	O	O	O
7. Push-button radio	O	O	STD	STD	STD
8. Heated rear window demister	O	NA	STD	STD	STD
9. Sliding steel sunroof (b)	O	NA	O	NA	O
10. Styled full wheel covers	O	O	STD	STD	STD
11. Vinyl Roof — Black, Brown, Beige	O	NA	O	NA	STD
12. White painted roof	O	NA	O	NA	O
13. Cloth seat trim	NA	NA	O	NA	STD
14. Body protection group (c)	O	NA	O	NA	STD
15. 175 SR 13 Radial ply tyres (d)	O	O	STD	STD	STD
16. BR70 H13 Radial ply tyres	O	O	O	O	O

Code for above: O means optional at extra cost, STD means standard equipment, NA means not available, O/R means optional at reduced cost.
NOTE: (a) The "Rallye" Pack consists of special black paint treatment and decal, sports road wheels, LHS rear view mirror, driving lights, leather-bound sports steering wheel, tachometer and simulated gear shift knob. (b) A vinyl roof cannot be specified with a sliding sunroof. (c) Body protection group includes full length side protection strips, and front and rear bumper over riders. (d) 175 SR 13 radial ply tyres are a mandatory option with 4.1 litre 6-cyl. engine.

FORD WARRANTY:
 Subject to such other conditions, warranties and/or undertakings which may apply from time to time under the laws of Australia and/or any applicable State or Territory thereof, FORD WARRANTS with respect to each new passenger or light commercial vehicle sold by Ford, that for a period of 12 months or 20,000 kilometres (whichever first occurs) from the date of original retail sale, FORD WILL repair or replace free of charge any part of such vehicle (except tyres) found to be defective in factory materials or workmanship under normal use and operation within Australia,
PROVIDED THAT:—

- the vehicle has been properly used, operated, maintained and cared for within the manufacturer's operation and capacity limitations, and
- the repair or replacement is carried out by an authorised Ford Dealer.

"Ford" means, Ford Sales Company of Australia Limited.

PLEASE NOTE:
 The illustrations, information and specifications presented and referred to herein were correct at the time when this publication was approved for printing; however, Ford Motor Company of Australia Limited and/or Ford Sales Company of Australia Limited reserve(s) the right, subject to the laws of Australia and/or any applicable State or Territory thereof and/or the regulations of any competent authority which may apply from time to time, at their or its discretion, and without notice, to discontinue or change the specifications, design and prices of the products referred to herein and any options therefor at any time without incurring any liability whatsoever to any purchaser thereof.
 Some of the items illustrated or referred to herein are optional at extra cost. Some options may be required in combination with other options. Always consult your Ford Dealer for the latest information on models, specifications, features, prices, options and availability.

FORD MOTOR COMPANY OF AUSTRALIA LIMITED
 FORD SALES COMPANY OF AUSTRALIA LIMITED
 1735 Sydney Road, Campbellfield, Victoria

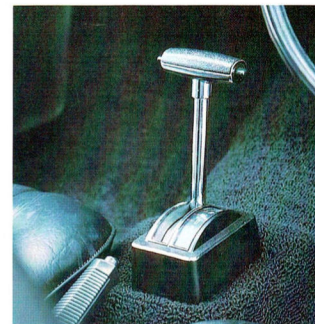

Extra cost options illustrated above: T-bar automatic transmission, sliding sunroof, sports road wheels and bumper over-riders.

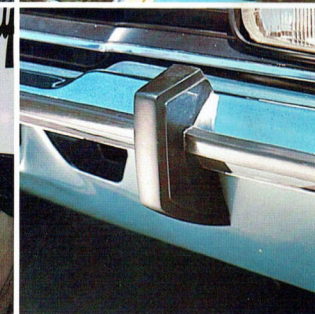

Driver and passenger protection features:

"Safety" glass all round with zone toughened area in front of driver • Windscreen mounted, break-away anti-glare rear view mirror • Articulated windscreen wiper action for wide-screen wiping • Dual-line braking system with instrument warning light • "Friction-disc" steering column isolates road shock and collapses on reaching predetermined level of impact load • 2-speed windscreen wipers and washers with control stalk on steering column • High-intensity quartz halogen headlights • Wrap-around front turn indicator and parking lights • Power assisted front disc brakes incorporating strong front disc pads • Radial ply tyres and rear window demister on XL and XLE models • "Safety-cage" passenger compartment — front and rear ends absorb impact shock progressively before it reaches the passenger compartment • Styled driver's side exterior rear view mirror • Double-lock door locks • "Child proof" locks on rear doors help prevent accidental opening • Reversing lights and wrap around tail, brake and turn indicators • Wide 5.0 x 13 inch "safety" rim wheels • Inertia reel front seat belts.

Dimensions/Capacities...

SEDANS:
 Overall — length (a) 4260 mm (167.7")
 width 1706 mm (67.1")
 height (b) 1315 mm (51.8")
 Wheelbase 2578 mm (101.5")
 Track — front 1422 mm (56.0")
 — rear 1422 mm (56.0")
 Turning circle 9.7 m (31.8ft)
 Ground clearance 147.3 mm (5.8")
 Fuel Tank capacity 54 litres (12.0 gals)
 Luggage capacity (c) .34 m³ (12.0 cu ft)

Note: All dimensions above, except (a) (b) and (c) are identical for sedans and wagons.

WAGONS:
 Overall — length 4361 mm (171.6")
 height 1325 mm (52.2")
 Load capacity
 — to front seat .95 m³ (33.2 cu ft)
 — to rear seat 1.81 m³ (63.8 cu ft)

Printed March 1976

FORD CORTINA



Ford Cortina.

The lively medium
for today's way of driving.

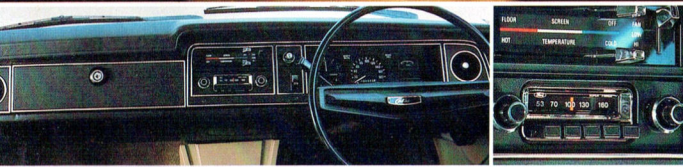

'76 Cortina-more features, better value-for-money.

Cortina is getting better all the time. With sporty blackout grille and co-ordinated interior colour schemes. The economy Cortina L and the superbly appointed Cortina XL now have more legroom for rear seat passengers than before. Even the luxurious Cortina XLE has been improved!

Cortina can be whatever you make it. With a thrifty 2 litre four, or smooth 3.3 and 4.1 litre six cylinder engines. With sporty 4 on the floor manual or convenient T-Bar automatic transmission. What's more, you have the convenience of national Ford Dealer back-up service.

Cortina XL. True car comfort in a size for today.

If you can't afford to buy big,

yet you can't shoehorn your family into something small... Cortina XL is your logical choice! Cortina XL's high level of standard equipment has made it the most popular Cortina. There's carpets, reclining bucket seats, deluxe push-button radio, electric clock. Convenient steering column control stalks put turn indicators, lane change, high-low beam, head-light flasher, horn and windscreen wiper/washer action at your fingertips.

And for '76, Cortina XL has rectangular quartz halogen headlamps, radial ply tyres and electrically heated rear window. How's that for features?

Other Standard Equipment items are: 2 litre 4 cylinder overhead cam engine, 4 speed floor shift, front power disc brakes, inertia reel front seat belts, centre console with armrest, folding centre armrest in rear, full wheel covers.

Printed March 1976

Cortina L and XL Wagons. The medium-sized Wagons that are big on features.

Cortina wagon is the most accommodating in its class. There's ample room for a family and almost 1 cubic metre of load space.

Fold the rear seat down and the load space increases to 1.8 cubic metres. For easy-opening convenience, Cortina wagon has a one-piece counter-balanced rear door.

Now, '76 Cortina Wagons look classier than ever. With sporty grille and co-ordinated interior colour combinations. '76 Cortina L and XL Wagons have quartz halogen headlamps. Inside, the 'L' model has bigger armrests and '76 Cortina XL Wagon has radial ply tyres, a rear window demister plus all the comfort and convenience features of the XL sedan!

Standard Equipment highlights common to L and XL Wagons: 2 litre overhead-cam four teamed with 4 on the floor transmission and power front disc brakes... front inertia reel seat belts... steering column stalk controls for turn indicators, lane change, high/low beam, headlight flasher, horn, 2-speed windscreen wipers and washers... Contoured and reclining, high-backed front bucket seats... Carpeting Ventilation system with individual ball vent controls, separate foot level vents... 2 speed heater/demister... Cigarette lighter... Courtesy lights... Reversing lights... Right hand exterior rear vision mirror.

Additional XL Wagon highlights:... Push button radio... electric clock... carpeted load space... rear window demister... radial ply tyres... styled wheel covers... console with storage bin and package tray between front seats... glove box light.

Printed March 1976

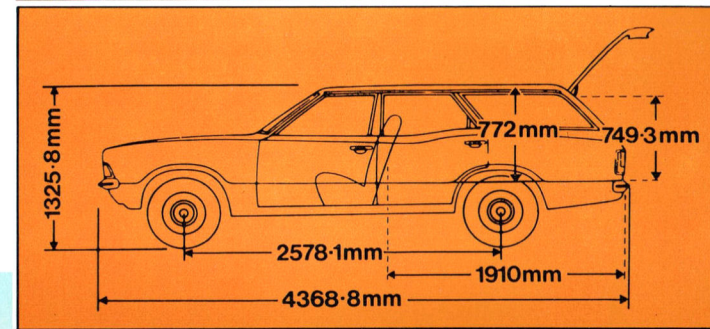

Cortina L. A "Rallye" Pack turns it into a sporty-looking machine.

You'll have trouble convincing your friends that '76 Cortina L is the low-priced model. Look what you get - carpets, reclining bucket seats, European style steering column control stalks, power front disc brakes and the lusty 2 litre OHC four cylinder engine matched with a slick four speed floor shift. Of course, you can specify '76 Cortina L with either of the big sixes, and T-Bar automatic.

Cortina L is getting better all the time, too. For '76, there's rectangular quartz halogen headlamps, sporty blackout grille and colour keyed interior combinations. The optional "Rallye" pack comprises: 8 spoke sports road wheels, rocker panel blackouts, black door handles and bumpers, leather-bound steering wheel, tachometer, simulated leather

gear shift knob, quartz halogen driving lights.

Sports handling suspension is optional too. Of course, you can specify the "Rallye" pack with the '76 Cortina XL sedan and wagon too.

L Standard Equipment Highlights: Contoured, cushioned high-backed reclining bucket seats... Carpeting... Rectangular quartz halogen headlamps... Power front disc brakes... Steering column control stalks for turn indicators, lane change, high/low beam, headlight flasher, horn, 2-speed windscreen wipers and washers... Ventilation system with individual ball vents and separate foot level vents... Front inertia reel seatbelts... Interior courtesy lights operated by front doors... Cigarette lighter... Styled right hand exterior rear view mirror.

Illustrated right: Cortina L interior with optional T-bar automatic transmission (Available at extra cost). Illustrated below: Cortina L with optional "Rallye" pack and 4.1 litre 6-cylinder engine (available at extra cost).

