



Inspiring Performance

**MOHAVE**





## Urban charisma

The energy of the city and the demands of the great outdoors bring out the personality of the new Mohave. With its strength, comfort, style and functionality it's born to thrive in and beyond the urban jungle.







## City escape

A strong and purposeful front image sends out the message loud and clear: Mohave takes ownership of the city streets. The smooth ride and elevated driving position put you at the head of the pack.





## Forward thought

As the Mohave passes by it exudes an air of majestic confidence; a muscular lion on the prowl. Its inner power is never in doubt with its sculpted stance pitched forwards by smooth flowing lines.





The perfect driving position

The Mohave cockpit has been fashioned to make a world of difference to your driving experience, day or night. From the textures and colours of the dash to the positioning of each button and dial, you'll appreciate Kia's attention to detail.



## Putting you in the driving seat

To feel in complete control when you're navigating off-road as well as cruising the city, you need every technological and practical advantage at your fingertips. The Mohave's cockpit gives you this and more. It combines a modern sports utility feel with high-tech embellishments across the dash to create an image that's as strong as the exterior. The interior design concept ensures you appreciate the volume you'd expect from a large SUV with the luxury and comfort of a high-specification sedan. Ergonomic controls have jog-type switches for ease of use. The balanced design ensures excellent visibility of the road ahead in addition to the well-styled and futuristically red-lit gauges, placing you firmly in the driving seat.



### Mood lamp

The mood lamps located within the door trim provide reassuring interior lighting within the cabin in the dark.





Sound and vision in unity

## Equipped for the future

Step into the Mohave and you'll see a glimpse of the inner future of the SUV. From the centre fascia to the gauge cluster and temperature control units, the Mohave embraces the Kia mantra of 'exciting and enabling'. The driver's controls embody modern and high-tech thinking which elevates the already state of the art technology. The sporty red lighting infuses distinctive and sophisticated energy across the audio centre, with a graphic user interface you would expect to see on high-end marques as standard in this vehicle. The supervision cluster option displays priority information for optimum driver support, while a simple push of the smart button ignition control fires up your Mohave - and your imagination.



Smart Key



### Manual air conditioner

Control the interior climate with manual air-conditioning as standard, with rear air conditioning and heater plus climate control options available.

### Smart key system with push button start

You can forget fumbling for keys with the keyless entry system and smart button ignition, where a simple push controls the start and stop of the engine.

### Analog Cluster

The stylish in-dash gauge cluster is much more than a sophisticated piece of design. It is placed in a way that emphasized simplicity and cleanness, allowing the driver to quickly scan basic information.

### ► Supervision Cluster

The supervision cluster option puts valuable driver information in immediate view to enable the driver to make optimum decisions.



▲ Trip computer





## Room with a view

Mohave defines a new standard in SUV comfort zones. The interior is spacious and the seating and suspension ensure all seven occupants ride in relaxed comfort, whatever life's journey has in store.





## Take it to the extreme

Be sure about one thing. The Mohave can tame the most extreme elements of nature. This new SUV has been developed and tested on the most challenging terrain to provide a driving experience that takes life off-road. Kia Mohave is born and bred in the Mohave Desert, and has pushed its capabilities to the limit in the harshest environments - and has truly earned its name.







Putting the pulse into power

▲ V6 3.8 Gasoline engine

The innovative Lambda engine delivers improved fuel efficiency, reduced emissions and overall improved engine performance.



▲ V8 4.6 Gasoline engine

The advanced Tau engine offers maximum performance, with optimal torque, air intake and smoother engine power delivery.

## The power to perform

You choose the power, and Mohave delivers. From the robust and fuel-efficient 3.0-litre diesel to the Lambda 3.8-litre and Tau 4.6-litre gasoline powerhouses, the engine options are designed to suit your lifestyle and driving style. The 3.8 and Tau 4.6 engines are mated to responsive gate-type automatic transmission systems, 5-speed in the case of the 3.8 and 6-speed with the 4.6. The 3.0 diesel is mated to a high-torque 8-speed automatic. The advanced four-wheel drive system customizes power distribution to the front and rear wheels based on road conditions and your driving habits. You can switch between full-time 4WD, which automatically adjusts power using sensors, and part-time 4WD for manual decisions on stability and fuel economy. Kia's Rough Road Escape Apparatus locking differential gear will help Mohave retain traction and cope with the most difficult terrain including snow, ice and unpaved roads.



**V6 3.0 CRDi Diesel engine**

The S 3.0-litre diesel combines a fuel-efficient CGI (Compacted Graphite Iron) cylinder block and 2<sup>nd</sup> generation piezo dual common rail system to minimize emissions and promote power output.

**8-speed automatic transmission**

The 8-speed is mated to the 3.0-litre diesel engine for maximum torque and greater fuel efficiency.

**2WD**

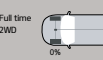

**4WD**

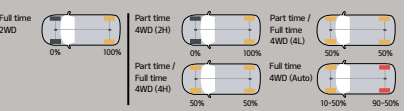





Redefining safety inside and out

## Safety when you need it most

No one can predict a collision occurring, but you can trust Mohave will protect you should the unforeseen happen. The Mohave body shell and innovative frame-type structure is designed to absorb the energy of an impact while the rigidity of the body structure and chassis gives occupants maximum protection. The extra strength of the dual dash panel contributes further to driver and passenger safety, enhanced by the Depowered airbag system - including safer depowered dual front airbags that have lower pressure impact. The curtain and side airbags feature rollover sensors which anticipate and engage airbags simultaneously to cradle and protect passengers. The front seats have an active headrest option which works with the body to move forwards and upwards during a rear impact collision, thereby preventing neck and head injury.

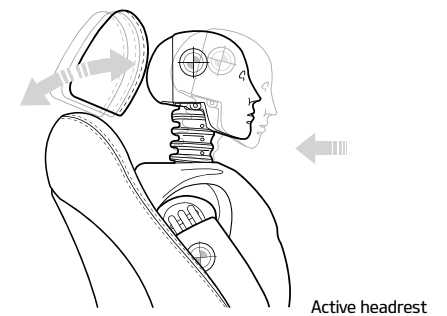

### Auto light control system

Visibility during a period of poor light can be a safety concern, so an automatic feature switches on Mohave's side lights when it senses it is too dark.

### Rear display room mirror

The Mohave gives you a clear view with the rear display room mirror. It will display rear images on a 3.3 inch LCD panel located on the ECM mirror for maximum safety.

### Rear parking assist system

The fender-mounted parking assist sensors help prevent collisions when reversing by identifying objects or obstructions (including people) and emitting an audible warning signal.



### ▲ Side and curtain / front airbags

Depowered airbag system features dual front, side and curtain airbags which protect occupants in the front, middle and rear seats during side impact or vehicle rollover.





## Conquering the ups and downs

Even on city streets it is essential that a capacious vehicle like the Mohave has the agility to climb and descend hills and deal with sharp turns. Mohave promises safer maneuvering thanks to systems like Electronic Stability Control (ESC), which responds to abrupt turns, acceleration and braking particularly on low friction road surfaces. Using real time electronic inputs, factors such as brake pressure and engine output are controlled, thereby increasing driving stability. As the Mohave descends hills you can count on DBC (Downhill Brake Control).

It automatically maintains constant speed without operation of the brake pedal and improves handling performance with concentrated steering power. When the Mohave needs to climb steeply it uses HAC (Hill-start Assist Control) to prevent slipping during stop and go on the incline.



▲ DBC (Downhill Brake Control)

DBC controls the braking mechanism on steep slopes or downhill conditions, maintaining a safe constant speed of 8 km/h.



▲ HAC (Hill-start Assist Control)

Using HAC, braking is sustained for two seconds during the brake-to-drive transition to improve driving stability and prevent roll-back and slipping which could endanger the vehicle and other road users.





A move forward for comfort and protection

## Driven to enhance your safety

Kia understands that the safety of your passengers and other road users is paramount, and the Mohave truly delivers the safest advancements in braking and suspension technology on. The Driving Safety System combines ABS brake control to enable you to maintain steering while braking; TCS accelerator control to prevent skidding as you accelerate; and ESC (Electronic Stability Control) yawing and rolling control to keep the Mohave stable and avoid rollover and lane veering by monitoring engine output, wheel motion and external conditions. In addition to rear electronic stability air suspension, the Mohave has double wishbone front suspension for excellent stability and ride comfort, and independent multi-link rear suspension for superior load handling and impact damping.

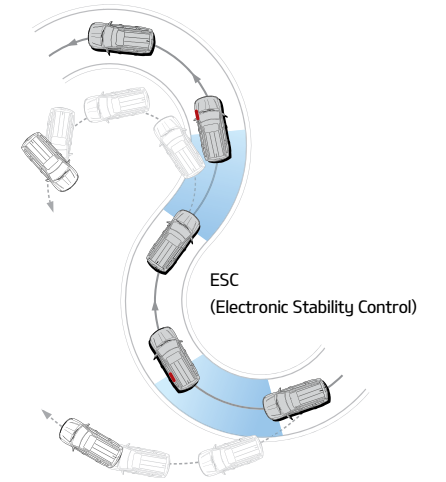

### Disc brake

Front and rear disc brakes form the 17 inch mass brake system, alongside electronic BAS (Braking Assist) which amplifies physical braking power. This gives Mohave unsurpassed all-disc stopping capability of 100 km/h to stop in 42.6 meters in Kia tests.



### Front suspension

The double wishbone front suspension focuses on the Mohave's ability to combat sharp inclines and retain turning stability, providing a firm and comfortable ride whether off-road on on-street.



### Rear suspension

Multi-link suspension dampens the shock of rough road surfaces, keeps Mohave stable when turning and maximizes interior space for all-round occupant comfort.

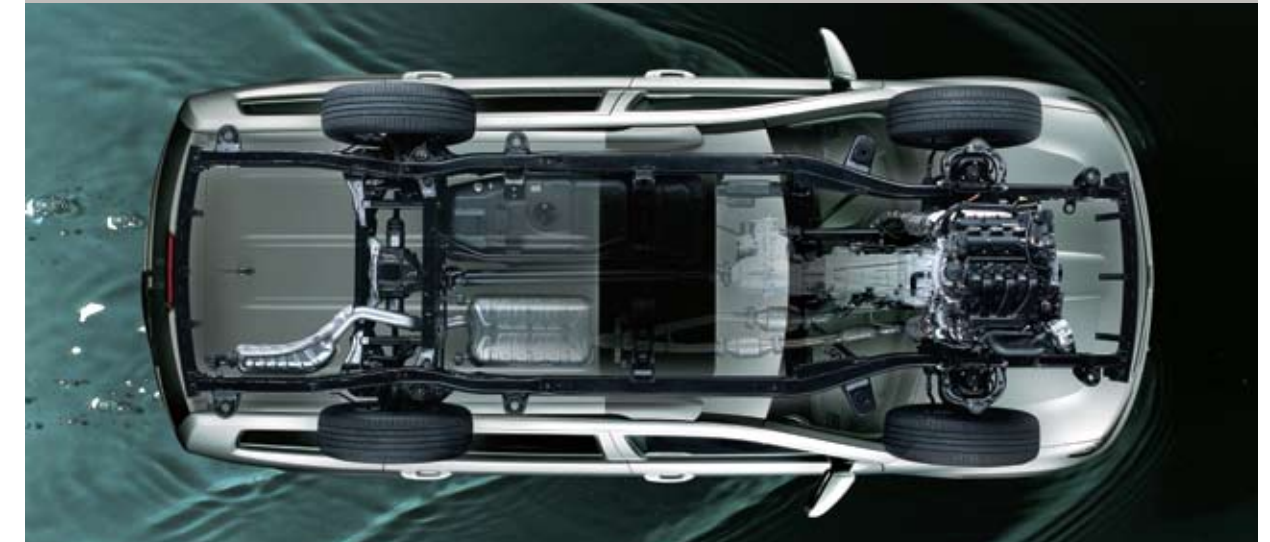





## Active safety in any environment

If you're heading off-road you'll be taking some serious active safety systems with you. The Mohave features the latest advancements in chassis and suspension technology, combined with enhanced braking capability, which will retain Mohave's grip and stability over the roughest terrain. Smart electronics ensure that suspension, wheel motion and engine output combine to minimize roll-over risk and keep the Mohave agile, responsive and adaptable to the conditions. The electronic tilt and telescopic steering wheel improves wheel rigidity and ease of use. Even the accelerator pedal has electronic motion control to prevent driver fatigue and keep you and your passengers as safe as possible.



### ▼ Rear electronic control air suspension

Driving stability and ride comfort are improved with rear electronic control air suspension. It enables the continuous maintenance of vehicle height regardless of the load and number of passengers. You can manually choose off-road driving mode to elevate the rear to avoid damage to the back end of the Mohave, and loading mode to lower the rear for convenience.

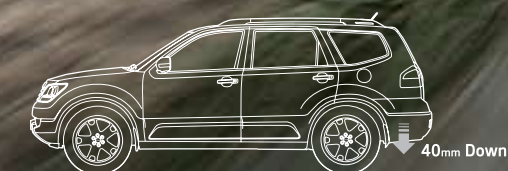



# Comfort and capacity inside

In the Mohave you will experience the luxurious interior of a high-end sedan yet with the functional amenities of an SUV for a practical, pleasurable driving experience. There is creative storage space and convenience at every glance, fulfilling every imaginable function. Luxury comes with a sharp eye for design detail, quality craftsmanship and prioritization of every driver and passenger's preference. The 10-way adjustable driver's seat is a typical example of this, ensuring you achieve a perfectly relaxed driving position at the light push of the control switch. The seat adjusts in 8 directions, offering excellent support to all areas of the back with a drum-type adjuster for a snug, customized lumbar fit and greater comfort for all driving conditions.



**Overhead console:** The unique overhead console provides more practical storage space for front and rear seat occupants. As well as housing the interior courtesy lamps there are three drop-down sunglasses holders which open with a simple push and fold away so neatly you may not even notice they are there.



**Door map pocket:** Keeping maps and tickets close at hand is important to a driver, which is why a convenient map pocket can be found within the front door trim. The pocket includes a smart niche in which to store drinks bottles without spillages.



**Seat warmer:** On a frosty day the seat warmer comes into its own. At the push of a switch it gently warms the seat cushion and backrest. For passenger comfort a seat warmer option is available for the second row seats.



**Centre console:** The centre console is far more than a comfortable armrest. Beneath is a spacious storage box, mounting for the rear ventilation ducts, and a cup holder.



**Cup holder:** The larger size of the centre cup holder allows for the safe and spill-free storage of mugs and cups. There are also convenient cup holders within the second row armrest, the floor console and rear seat storage areas.



**Glove box:** The large-sized glove box compartment provides enhanced convenience and sophistication. It features a locking mechanism for safekeeping of items, a lamp to help illuminate items in the dark and a damper for smooth and controlled opening.

**Seat variation:** The beauty of a sports utility vehicle is its flexibility, giving you the ability to be prepared for the unexpected. With seven seats you can carry your extended family or friends in comfort and safety, with all the modern conveniences that Kia has included in the Mohave. The seat folding arrangements increase the possibilities, enabling you to combine storage options for lengthy or bulky items alongside your passengers. You can fold the second and third rows completely flat; split the back row 50/50; or split the centre row 60/40 as required. The large tailgate opening makes loading a breeze, and combines with an automatic locking system to ensure the tailgate locks with the very slightest push.



3<sup>rd</sup> row folding



Partial 2<sup>nd</sup> row & 3<sup>rd</sup> row folding



2<sup>nd</sup> & 3<sup>rd</sup> row partial folding



Partial 3<sup>rd</sup> row folding



**Second row walk-in:** The Mohave seating features improved entry into the vehicle's third row with an easy to maneuver access lever located on the right side of the second row seat. This row also features 60/40 seat back and cushion, full fold flat sliding and double reclining.



**Cargo under floor storage compartment:** Convenience is paramount in a family vehicle, and the under floor storage compartment at the rear is valuable. It enables you to store useful items out of sight, out of light and keep them handy at all times.



**Cargo net:** It is vital to keep loose objects contained within the rear storage area, both to protect the occupants and items. The cargo net is a great way to hold the items safe and is large enough for storing even large objects upright and secure.



**Automatic tailgate:** The innovative locking system closes the tailgate completely with just a slight push. The sport touch feature of the outer handle also translates into higher customer convenience and easier opening capability, requiring only minimal strength be applied.





# The advantages of friendly technology



**IMS (Integrated Memory Seat) system:** Mohave electronically records settings for two different driver seating positions for automatic readjustment of the driver seat, outside mirrors and steering wheel. The steering wheel selects the most recent position when the ACC start button is activated, and the seat moves back 5 cm when P gear is selected to enable easy access.



**Sunvisor:** The pull-down sunvisor ensures less eye strain from sun brightness when driving, and also features a sliding mirror cover and separate illumination lamp. This combines with the windshield's tinted glass to help keep the cabin temperature cooler and subdue the sun's rays.



**Telescope wheel & electronic tilt :** The electronic tilt and telescopic steering wheel allows you to adjust its position for perfect driving ergonomics. It forms part of the Integrated Memory System, and retreats for entrance and exit when the engine is off and returns back to its desired position in ACC status.



**USB, AUX and iPod®:** The modern era of sound technology has boosted the popularity of MP3, mobile CD, DVD players and other electronic devices. Mohave ensures you're prepared with built-in USB and AUX sockets to enable you to take compatible devices on the road with you.



**Power window:** The one-touch power window is operated from the convenience of the armrest controls. The option of safety power windows is available, where the window will retract when it detects an obstruction, which is especially valuable for child safety.



**Centre room lamp:** The front and rear centre lamp console provides bright illumination on entry and exit of the vehicle if selected, with fade-out operation, or permanent lighting for map reading. Also featured within the front lamp console is a convenient drop-down sunglass storage case.



**Electric motion control pedal:** An electronic system can maintain the optimal driving position of the accelerator pedal by controlling the pedal height to prevent driver fatigue. It can be activated using the transmission lever and has an operating range of 75 mm.



**Rear seat air conditioner and heater:** Mohave some with an air-conditioning or climate control option that you may expect for front passengers. But additionally your rear passengers can enjoy the same level of luxury with air-conditioning and heating to help them adjust their preferred climate.

**Front cooled seat:** Summer driving becomes a breeze - literally - with the innovative Kia-designed ventilated driver's seat in the Mohave. The system has been developed through rigorous testing under conditions of maximum discomfort: temperatures of 38°C and 80% humidity. It is highly efficient and lightweight, with air blown directly from within the seat unlike the ventilated systems found in some high-end sedans. The controls allow for adjustable levels of cooling. At the push of a button the three-level blower draws in air and distributes it through the ventilated mats within the seat cushion and backrest. This will keep you cool even during extended periods of driving, and in combination with the heater element gives you perfect driving comfort all year round.



**HID (High Intensity Discharge) / Projection type headlamps:** The HID headlamps provide more intense clean light for a better view of the road for the driver, and a better view of the Mohave by other motorists. You also benefit from longer-lasting lamp life. (Running change (From Aug in 2008))



**LED rear combination lamps:** Application of these LED Lamps ensures excellent rear visibility, emphasizes the Mohave's luxurious image, and even promotes energy efficiency with longer lasting bulbs.



**LED repeater:** Road safety begins with clear indicators, and none are as clear as on the Mohave. The side repeater is mounted within the wing mirror, providing a highly visible signal. It features LED light for crystal clear vision and longevity.



**High mounted stop lamp:** Studies have shown that a high mounted stop light is a major contributor to road safety, making your intentions to slow down clearer to other road users. The Mohave's high-mounted LED stop light is located within the tailgate.



**Electric chromic mirror + compass:** Your view of the road ahead can be distorted by the glare of lights from behind. The electronic chrome rear-view mirror automatically adjusts to reduce glare from vehicle headlights behind you, and features a handy compass to help you gauge your orientation on journeys.



**Outside mirror (reverse with IMS):** When transmission is positioned R, the outside mirror is adjusted downward automatically so that the rear sight can be secured for safety.



## Take a load off your mind

As you would expect from a powerful four-wheel drive SUV, the Mohave has the flexibility to be a hobbyhorse or workhorse. From towing a quad bike or laden trailer at the rear to carrying a windsurfer board or packed roof box on the roof rails, Mohave makes heavy work look like a breeze.





## Colour combinations

### ► Beige two-tone

The beige colour combination provides a warm and relaxed interior with the stunning contrast of the black dash with metal and oak woodgrain trim. Whether you choose the fabric and leather seat combination or the rich full leather, the result is classic and elegant luxury.

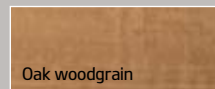
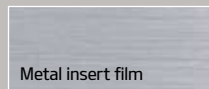

### ► Black one-tone

Modern and contemporary, the all-black interior provides a cool and fresh feel throughout the cabin. You have the choice of a leather and fabric seat combination, or full leather seating to complement the black woodgrain and metal insert trim.

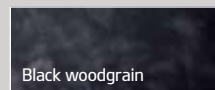
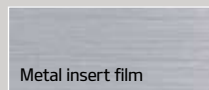



# The Mohave is...

**CONCEPT** The Mohave is a forward-looking Sports Utility Vehicle that combines the refinement and luxury of a high-end sedan with the rugged and sporty feel of an off-road four-by-four. It marries a robust body-on-frame structure with powerful engine options to fulfill a go-anywhere mentality, while having the refinements and technology to place Mohave in the upper echelon of its segment. High levels of performance and economy combine with segment-leading occupant safety to achieve a vehicle that sets a standard in functionality while making a statement that this is a true outdoor family vehicle.

**DESIGN** The Mohave shares the contemporary exterior design features that are desired in a modern SUV, but adds many unique and sculpted touches that set it apart from the rest of the pack. It has clean symmetry with linear square lines and moulding that frame its sturdy volume but also enhance its dynamic feel. Strong wheel arches and clean cut lines, from the chiseled hood to the flared rear headlamps, enhance its muscular appeal and ensure this big car retains its sporty credentials. Inside Mohave has a modern look that would be at home in a high-end sedan segment, with cleverly designed use of space, clean and crisp fit and technology that complements driver and occupant ergonomics.

**COMFORT** Driver comfort begins with the 10-way adjustable seating with Integrated Memory System to ensure the perfect position of seat, wing mirrors and steering wheel. The leather and fabric or full leather seating options give the Mohave a rich and elegant feel, with air-conditioning as standard plus climate control and rear air-conditioning options for all-round cabin comfort. Audio is of the highest quality with the superb Infinity sound system and built-in AUX and USB sockets to take your media with you. The carefully considered volume of the interior ensures ample head and legroom for all seven occupants, with storage and convenience throughout.

**SAFETY** The Mohave is one of the safest SUVs available. Active safety features include combined Electronic Stability Control, ABS anti-lock braking and Electronic Brakeforce Distribution to manage efficient cornering and braking performance. Downhill Brake Control and Hill-start Assist Control also provide improved stability and handling on slopes. Passive safety includes robust frame rigidity and crumple zones for impact resilience, and an advanced airbag system that includes dual front airbags, curtain and side airbags with rollover sensors plus active headrest option.

**PERFORMANCE** The Mohave provides three engine choices to suit your driving style. The Lambda 3.8-litre gasoline engine provides 274 ps at 6,000 rpm and 36.9 kg-m maximum torque at 4,400 rpm, and is mated to a fuel-efficient 5-speed automatic transmission. The powerful Tau 4.6-litre gasoline engine delivers 340 ps at 6,000 rpm and 44.4 kg-m maximum torque at 3,500 rpm, and is mated to a high-performance 6-speed automatic transmission. The S 3.0-litre diesel engine delivers 255 ps at 3,800 rpm and 56.0 kg-m maximum torque at 2,000 rpm and is mated to a high-torque 8-speed automatic transmission. The Mohave has full- and part-time 4 wheel-drive to enable it to combat rough terrain and maximize fuel economy.

**REFINEMENT** The Mohave's off-road capability is enhanced by double wishbone front suspension, rear-wheel multilink suspension and rear electronic control air suspension which maintains continuous vehicle height regardless of load and passengers, with manual adjustment for city, off-road and loading. Mohave's body-on-frame structure provides maximum comfort, reduced vibration and noise reduction in all terrain. Interior refinements include supervision cluster for enhanced gauge visibility, electronic tilt and telescopic steering wheel, and Integrated Memory System for driver's seat and steering wheel position.

## Specifications

Dimensions (mm)			
Overall length	4,880	Interior width	1,595
Overall width	1,915	Interior height	1,200
Overall height (Including roofrack)	1,810	1 <sup>st</sup> Row Headroom	1,015
Wheelbase	2,895	2 <sup>nd</sup> Row Headroom	990
Wheeltrack (Front)	1,630	3 <sup>rd</sup> Row Headroom	965
Wheeltrack (Rear)	1,640	1 <sup>st</sup> Row Shoulder room	1,530
Overhang (Front)	875	2 <sup>nd</sup> Row Shoulder room	1,500
Overhang (Rear)	1,110	3 <sup>rd</sup> Row Shoulder room	1,415
Interior length	2,660	1 <sup>st</sup> Row Legroom	1,060
		2 <sup>nd</sup> Row Legroom	950
		3 <sup>rd</sup> Row Legroom	835
		Interior volume 1 <sup>st</sup> Row (litres)	1,675
		Interior volume 2 <sup>nd</sup> Row (litres)	1,370
		Interior volume 3 <sup>rd</sup> Row (litres)	1,045
		Cargo volume Row (litres)	350
		Min. Ground clearance	217
		Fuel tank capacity (litres)	82

### Engine

#### 4.6-litre engine

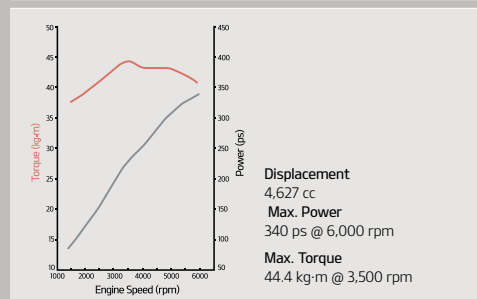

#### 3.8-litre engine

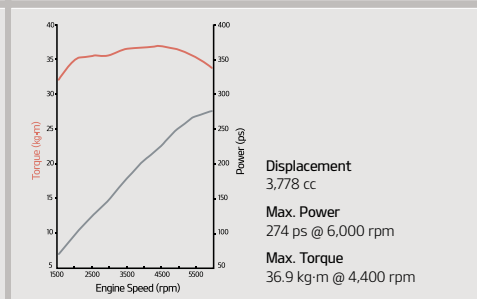

#### 3.0-litre CRDi engine

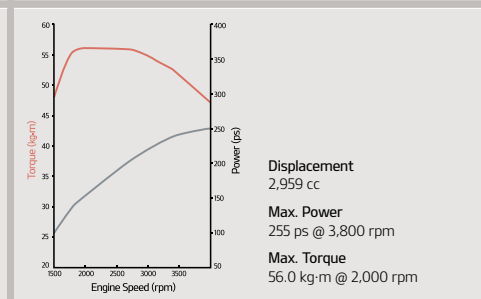

## Body colours and wheels

The Mohave has the paint colour choices to ensure you make a statement. You also have two wheel options (17 inch or 18 inch alloys) to complement your style.



Snow White Pearl (SWP)



Clear White (UD)



Bright Silver (3D)



Titanium Silver (IM) • Available until Jun. 2012  
Glittering Metal (K3G) • Available from Jul. 2012



Temptation Red (K3R)



Golden Beat (K3N)



Ebony Black (EB) • Available until Jun. 2012  
Aurora Black (ABP) • Available from Jul. 2012



245 / 70R17



265 / 65R18

## Dimensions (mm)

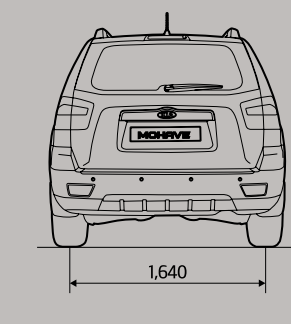
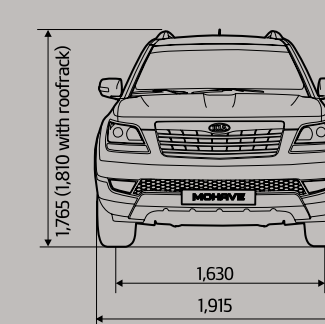
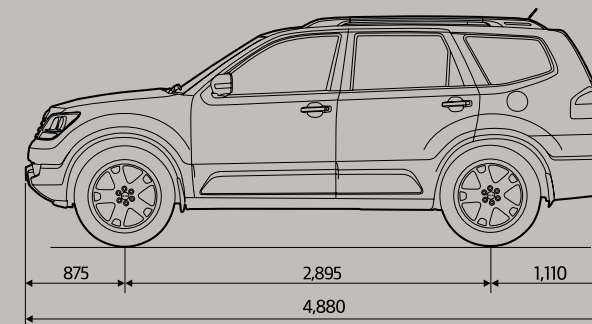

※ All information and illustrations are based on data available at the time of publication and subject to change without notice. Contact your local Kia dealer for current information.





### Kia Motors Corporation

231 Yangjae-dong, Seocho-gu, Seoul, 137-938, Korea

[www.kiamotors.com](http://www.kiamotors.com)

1205-JS-SW/GE-LHD

## The Power to Surprise

Kia is the newest and most exciting force of change in the automotive world and we are ready to change the way you feel and think about driving. More than just a promise, we are committed to making driving a true pleasure for customers across the globe. With youthful styling and the latest in advanced technologies, Kia cars are turning heads the world over with the power to surprise. From the Picanto to the Mohave, Kia offers a full lineup of sedans, SUVs and MPVs that are not only practical but downright exhilarating to drive. Keep your eyes on Kia because our best has yet to come.

### About Kia Motors Corporation

Kia Motors Corporation ([www.kiamotors.com](http://www.kiamotors.com)) -- a maker of quality vehicles for the young-at-heart -- was founded in 1944 and is Korea's oldest manufacturer of motor vehicles. Over 2.5 million Kia vehicles a year are produced in 15 manufacturing and assembly operations in eight countries which are then sold and serviced through a network of distributors and dealers covering 172 countries. Kia today has over 47,000 employees worldwide and annual revenues of over US\$39 billion. It is the major sponsor of the Australian Open and an official automotive partner of FIFA -- the governing body of the FIFA World Cup™. Kia Motors Corporation's brand slogan -- "The Power to Surprise" -- represents the company's global commitment to surpassing customer expectations through continuous automotive innovation.



Facebook  
Become a fan of kia

<http://www.facebook.com/Kiamotorsworldwide>



Twitter  
Follow us

[http://twitter.com/Kia\\_Motors](http://twitter.com/Kia_Motors)



Kia BUZZ  
<http://Kia-buzz.com>