

NEW FORD

MONEY- MAKERS

F500

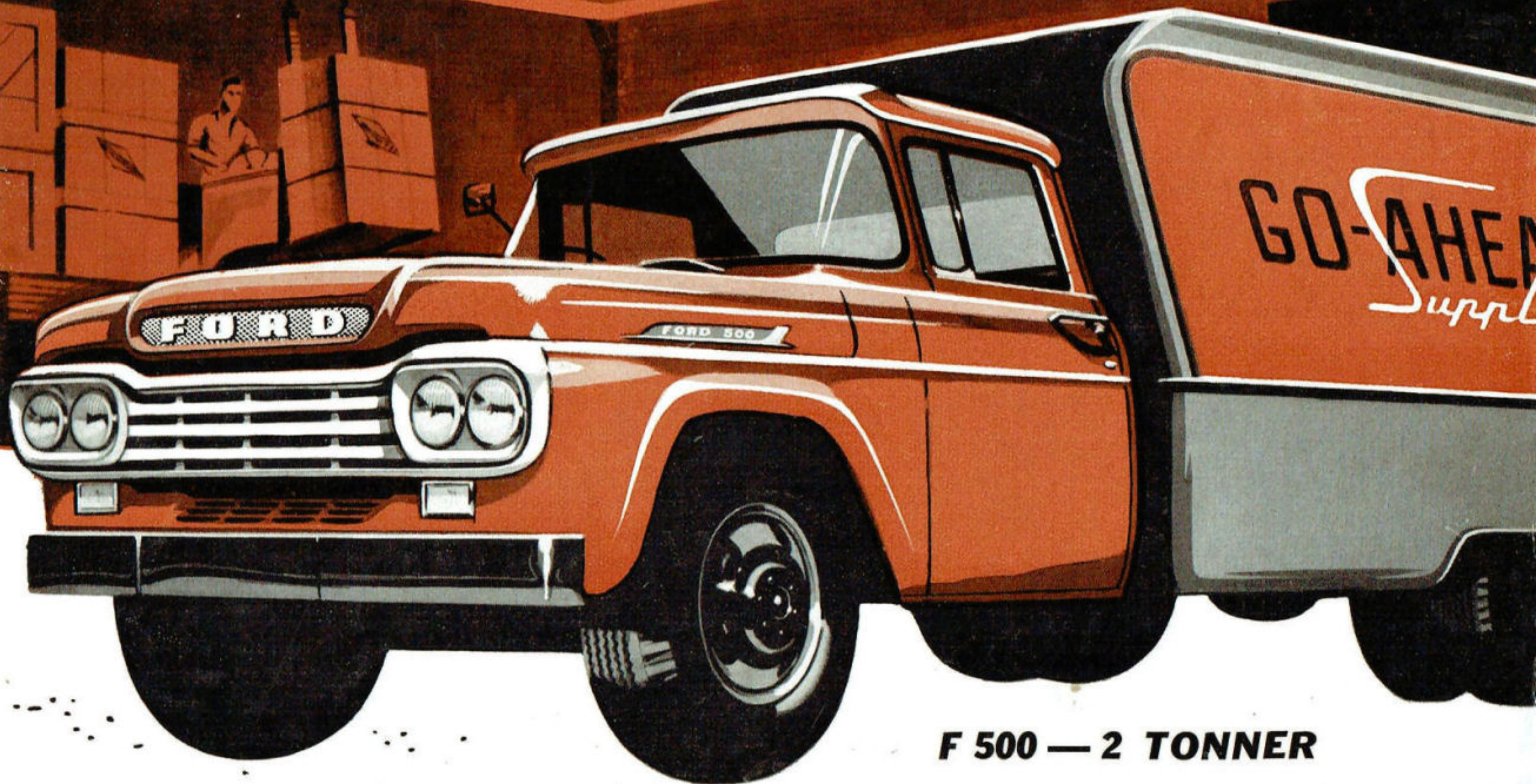

F 500 — 2 TONNER

FORD O.H.V. V8 TRUCKS

Money-saving O.H.V. V8 power

Ford's O.H.V. V8 engine gives you the fullest benefit of modern Short Stroke design. Thanks to Ford's Short Stroke design, pistons travel shorter distances, at slower speeds — resulting in less wear, less power-wasting friction, and more usable power is delivered to the wheels to do your

job. In addition, moving parts last longer to keep operating costs lower! And Deep-Block construction gives greater rigidity for long life and dependable performance. This is the most efficient V8 truck engine Ford has ever built, and Ford has built more V8 engines than any other manufacturer.

Precision-moulded rocker arms for greatest durability.

Free-turn valves (both intake and exhaust) for self-cleaning, better seating, longer life.

High-turbulence combustion chambers with higher compression for greater power output.

Full-floating piston pins for longer life.

Aluminium alloy autothermic pistons with steel struts for best performance.

Full-length water jackets reduce wear. Higher capacity water pump increases cooling at low speeds.

Long-lived, copper-lead main and connecting rod bearings.

Deep engine block for greater structural rigidity, smoother engine performance.

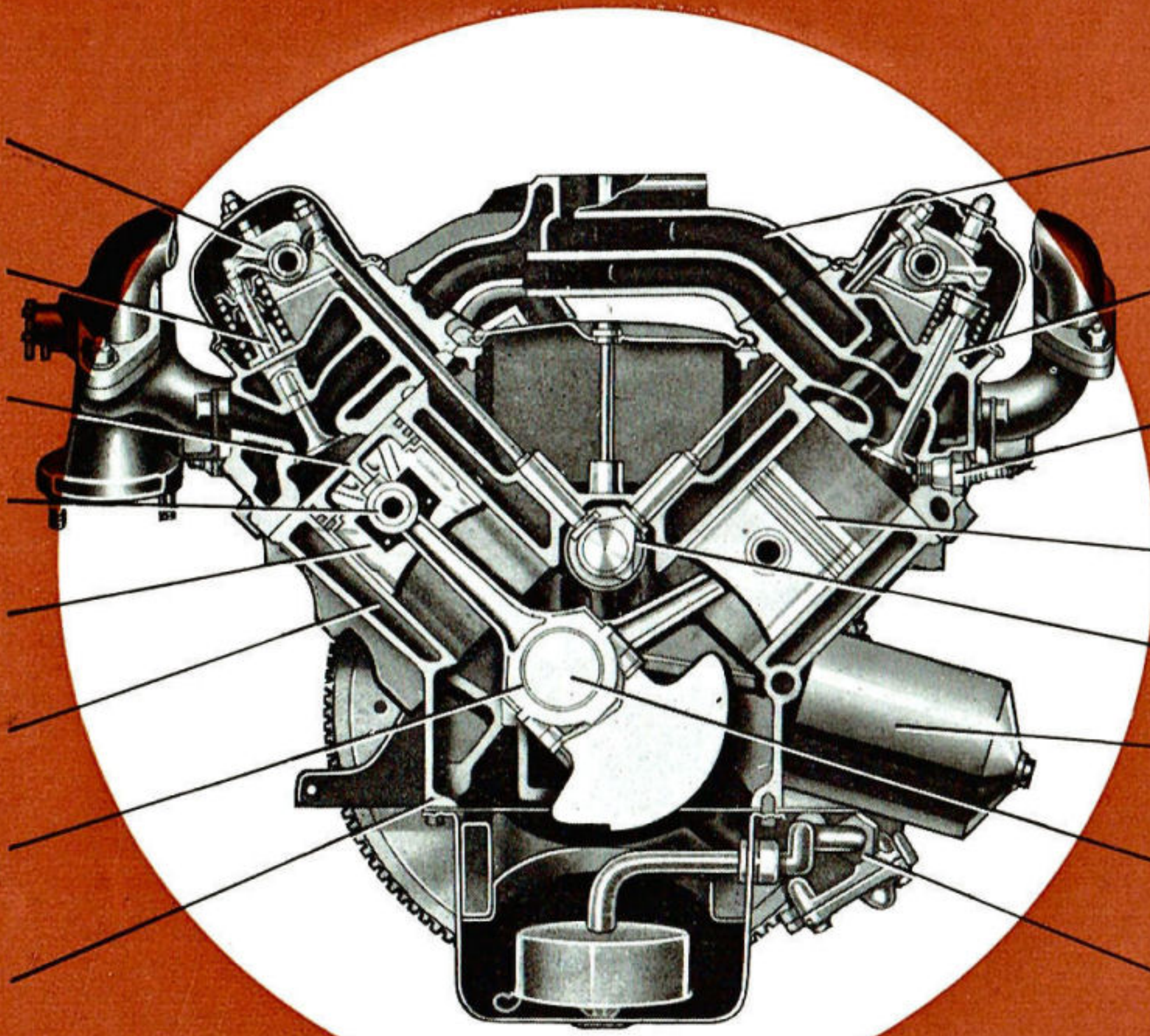

Larger short-reach intake manifold for quick, uniform fuel charge, easy starting.

Integral valve guides enable valves to run cooler, last 50% longer.

18-mm. "Turbo-Action" spark plugs — A Ford First, resist fouling with light loads, prolong peak power at full load.

Chrome-plated top ring prevents scuffing during break-in.

High-lift camshaft for wide valve opening.

Full-flow filter cleans all the oil, lengthens engine life.

Full-pressure lubrication of all crankshaft and connecting rod bearings for longer life.

High-capacity oil pump for positive lubrication, long life.

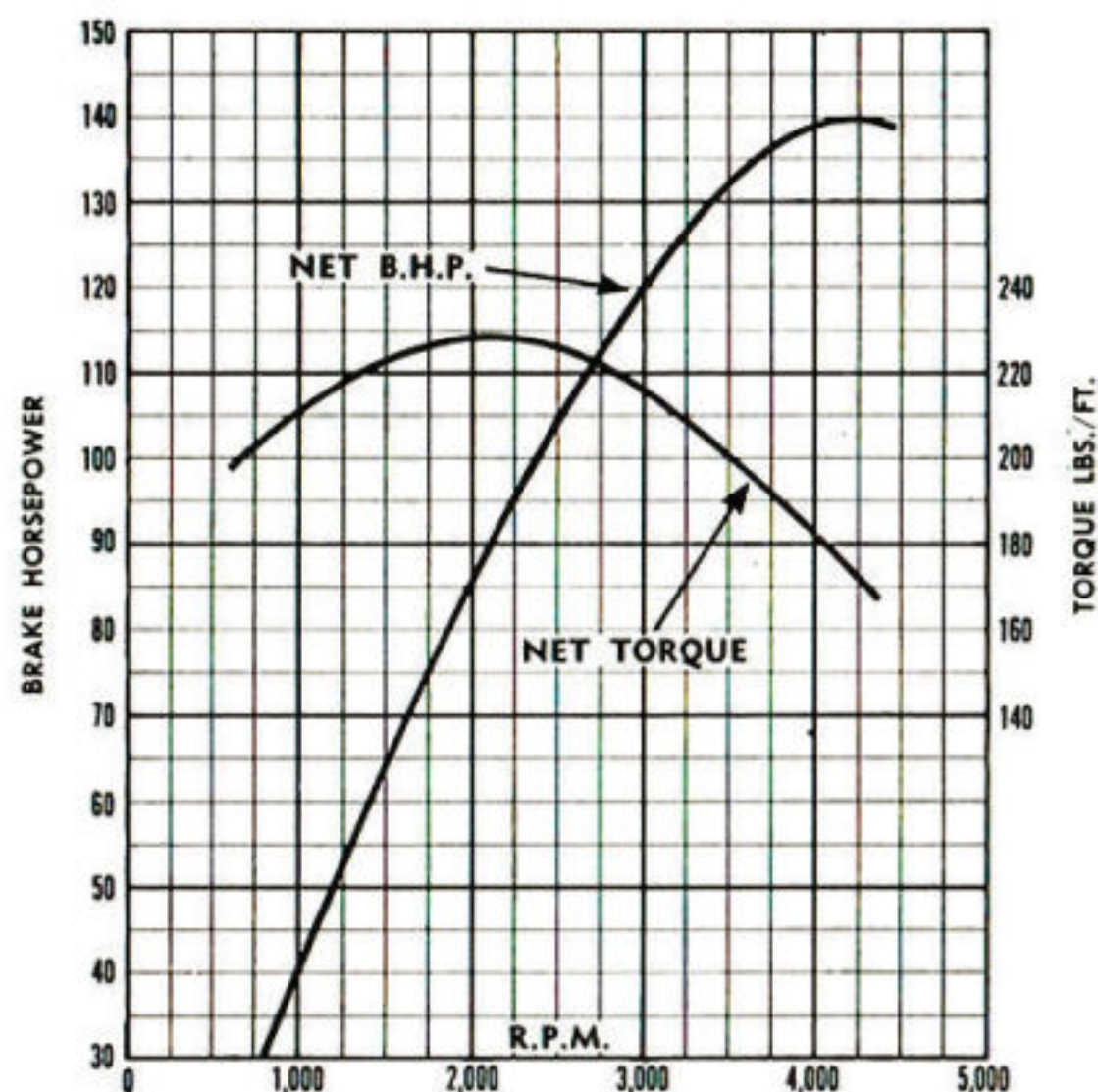

... plus the highest torque and b.h.p. in its field!

Here is far more horsepower per cubic inch displacement, and higher, more sustained torque for tough work, long hauls, and easier cruising speeds under heavy load conditions. Net maximum b.h.p. is 139 @ 4,200 r.p.m., and the high net torque of 227 ft. lbs. is attained at the low revolutionary rate of 2,200 r.p.m. Other reasons why Ford gives you more horsepower per pound are . . . 7.1:1 compression ratio . . . 12-volt electrical system . . . iron-alloy camshaft . . . exceptionally rigid crankshaft . . . and many other engineering advances.

Greatest cab value ever — with the most in comfort, safety, and convenience

Ford Driverized Cabs are big, comfortable, and extra strong. Features are engineered in to reduce fatigue, lessen tension, and provide the nearest ride yet to sedan-like comfort.

- 1 Full wrap-around windscreen.** Now there's 1,020 square inches in Ford's wider, full wrap-around windscreen. Vision is unobstructed forward, down and to the sides.
- 2 Look at the dimensions.** There's no squeeze in this cab . . . there's more shoulder room, leg room and added head room to make driving-comfort and passenger-comfort more relaxing, less fatiguing.
- 3 Inboard step.** Ford has moved the cab step up inside the door making it easier to climb aboard. It provides extra protection against water and slush—increases over-all cab strength.
- 4 Doors open wide.** Doors open almost a full yard wide—are held open by door checks. It's the easiest cab to get into and out of on the road.
- 5 Complete weather sealing.** Doors and wing vents are completely encircled by tight fitting rubber seals . . . keeping out dust, fumes, moisture and draughts.

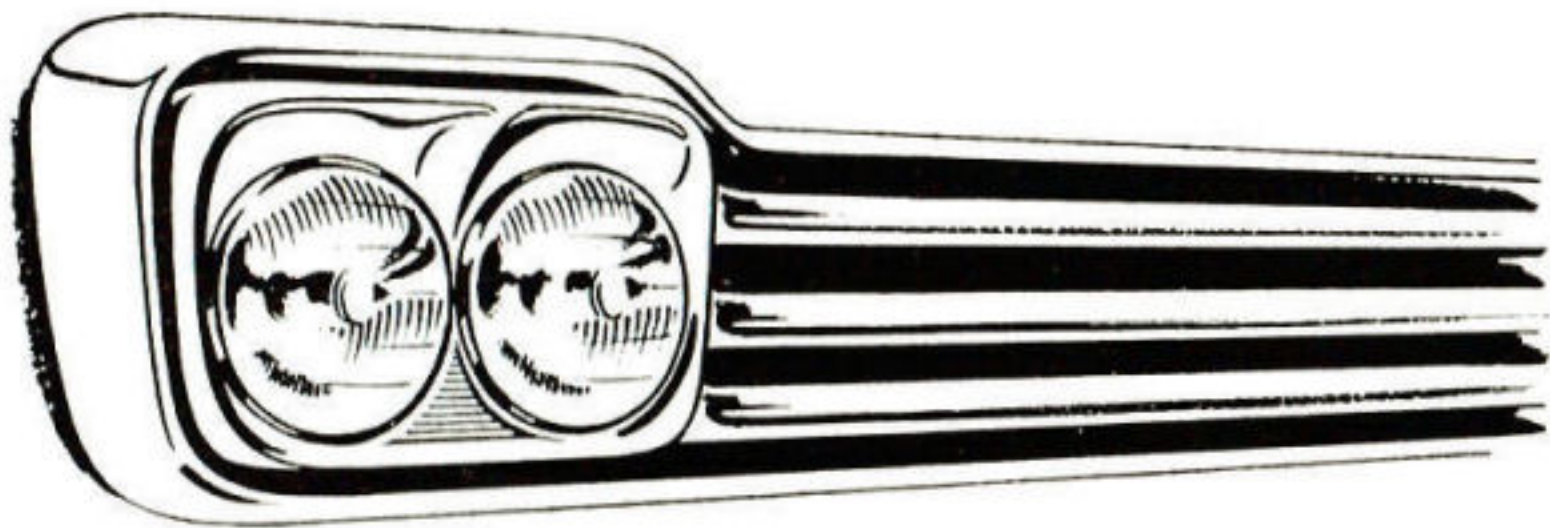
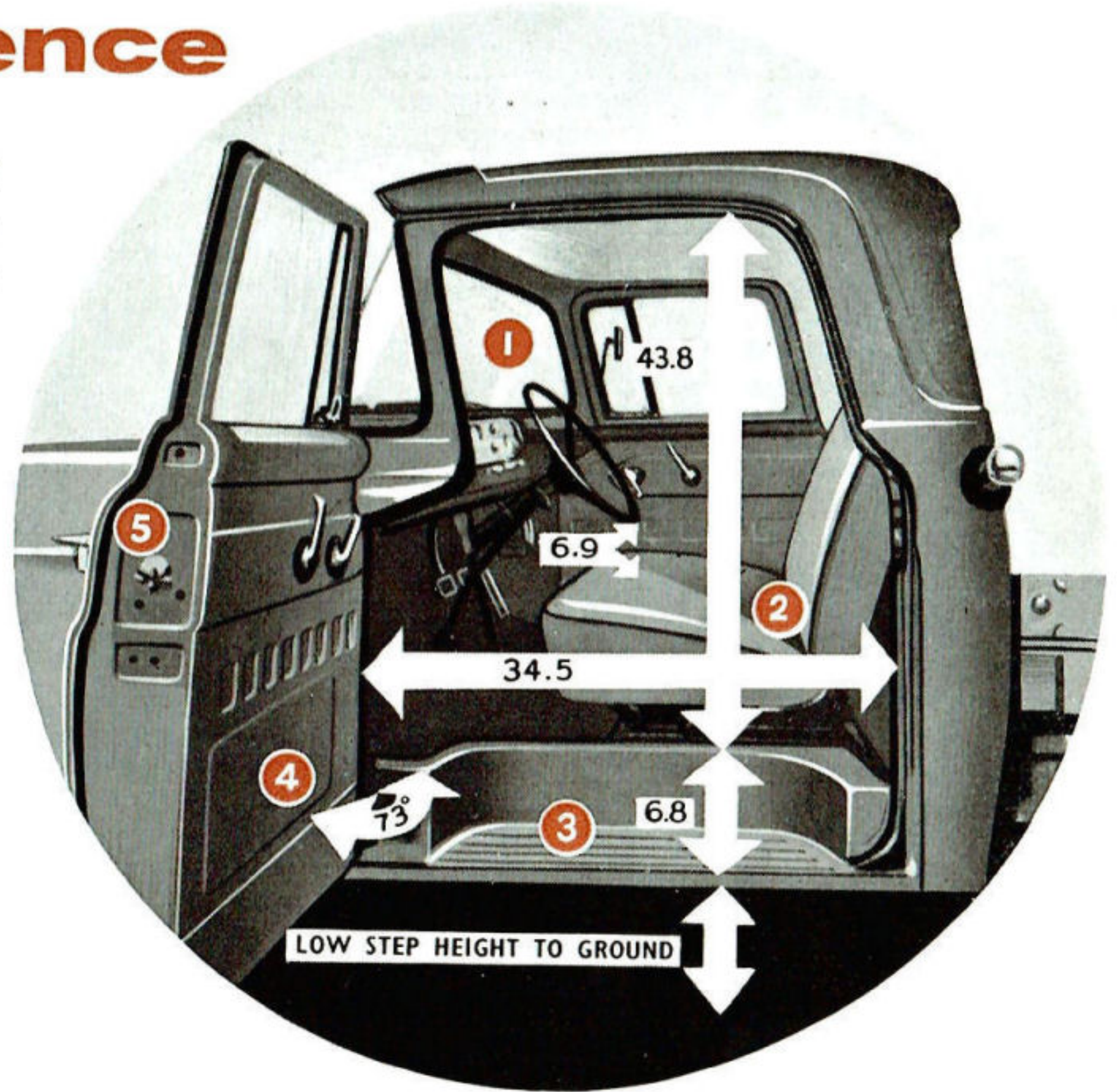

Dual headlights for safety and smartness

The dual headlight system on all Ford V8 trucks present a major improvement in lighting efficiency together with positive lighting control for added safety. Long range driving lights utilize four fixed filaments — one in each headlamp lens. The dipped beam has fixed focus spread pattern control in the outboard lights only, giving improved low-beam visibility.

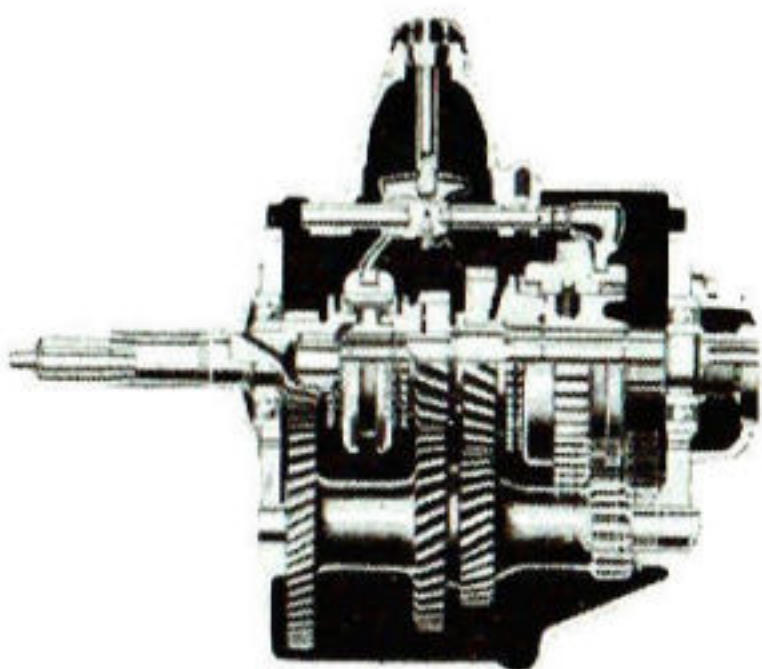

4-SPEED HEAVY DUTY SYNCHRO-SILENT TRANSMISSION

Standard equipment, it provides more "pulling" ability plus more flexible and economical operation with heavy loads than 3-speed transmissions.

Eliminates "Double-clutching", provides more safety in down shifting. One-piece clutch and fly wheel housing provides smoother, more reliable power flow and more strength for longer life.

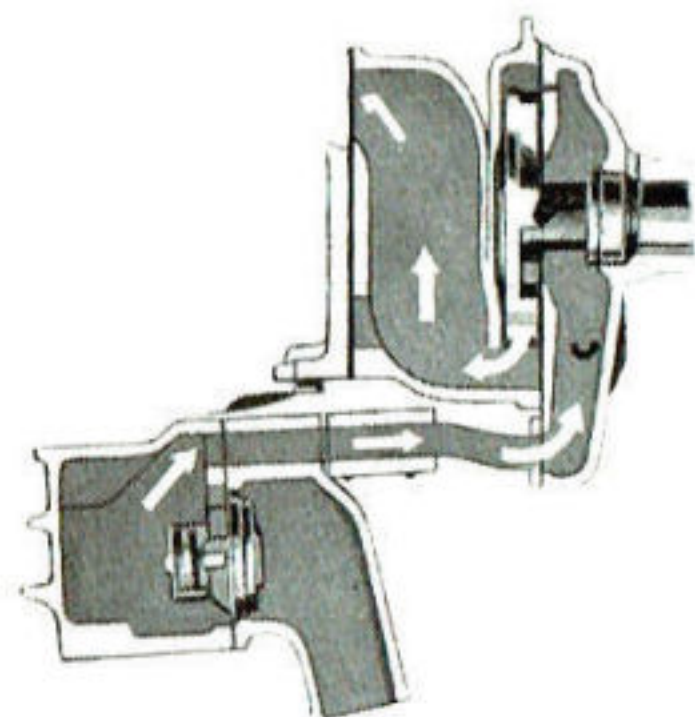

High capacity water pump

Ford's highly efficient water pump increases the water flow, reducing the possibility of heating at low speed or idling. The positive-action thermostat is unaffected by varying pressures, and constantly regulates the coolant.

Ford's rugged chassis design cuts ton mile costs!

Parallel ladder-type frame construction features heavy gauge channel side members and flanged "U" type cross members. Frames are of SAE standard 34" width to facilitate mounting of standard or custom-built bodies. Deep, wide-flanged side members extend beyond the front cross member to permit direct attachment of the front bumper which also serves as a cross member. And all cross members are strategically placed in frames to resist torsional stress.

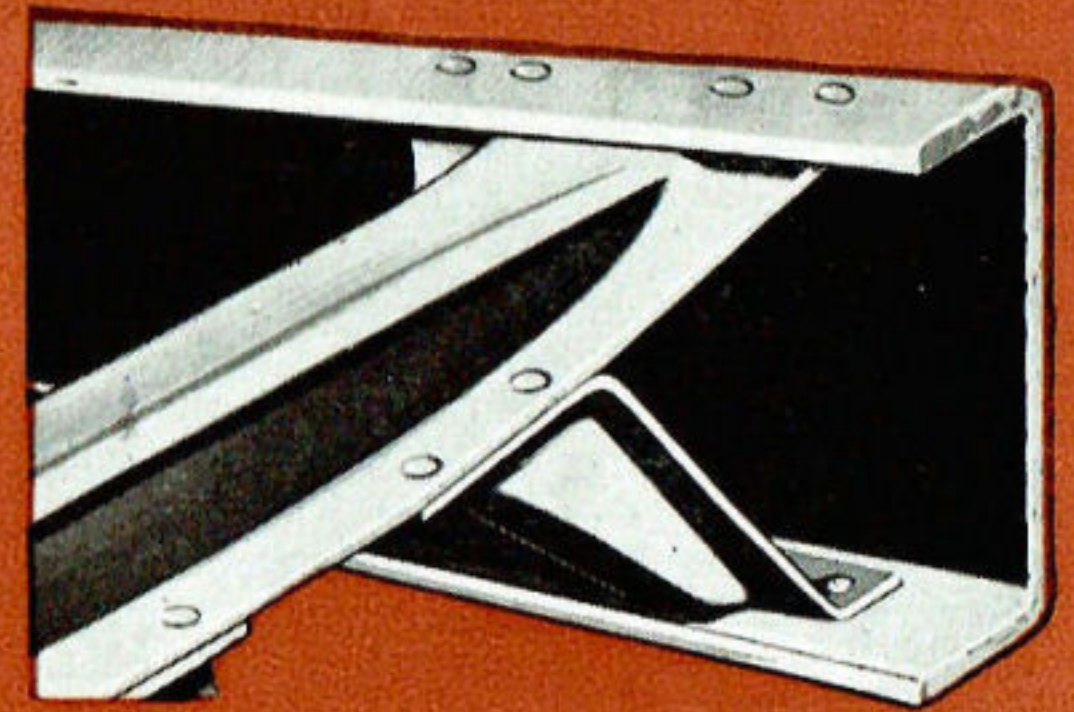

Wheelbases	Max. Side Rail Section	Section Modulus	Number of Cross Members
130"	7.08" x 2.77" x 0.25"	6.24"	5
154"	9.25" x 2.94" x 0.25"	9.45"	6

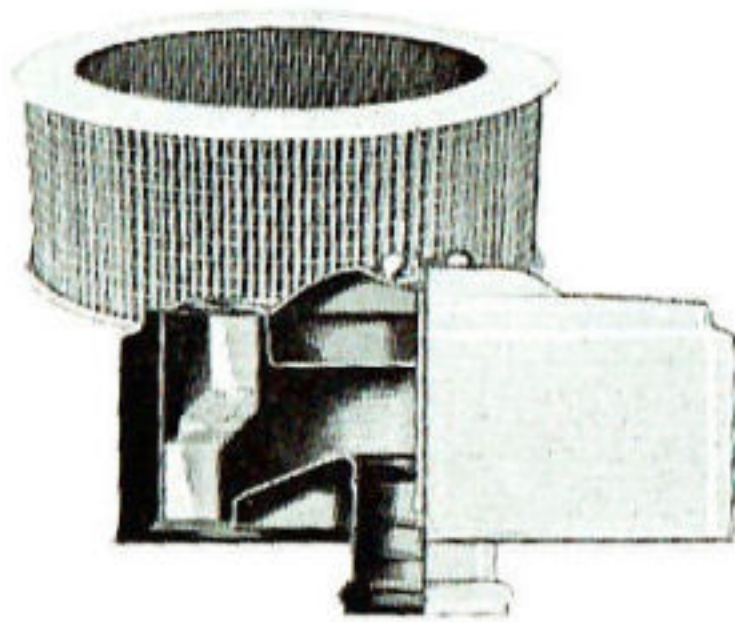

New Super Air Cleaner

Ford's new dry element Air Cleaner is pleated in accordion-fashion and is up to 90% more efficient than the oil-bath type cleaner. The filter is re-usable too, cleaning being easily accomplished by removing the element from housing and tapping firmly on a flat surface.

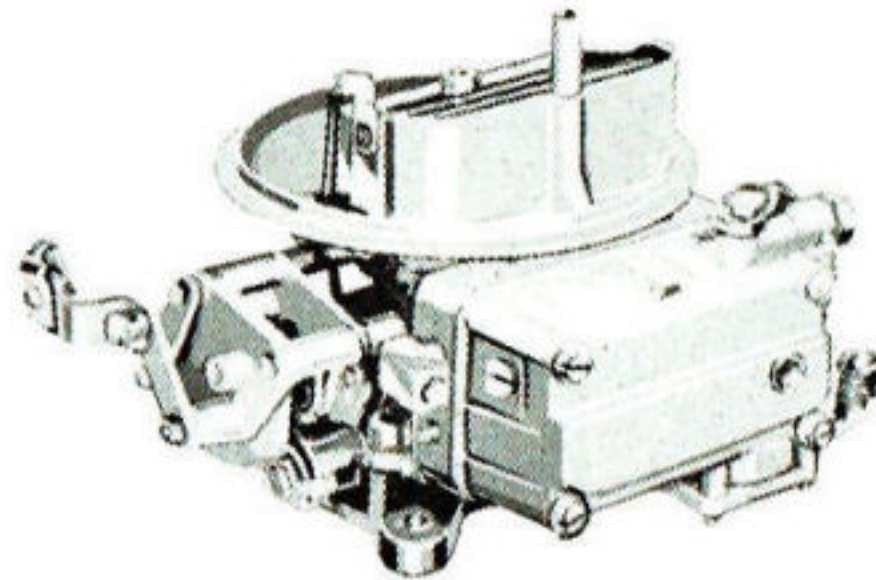

New Carburettor

The new dual-venturi carburettor is of low silhouette type—unique for its compactness and convenient unit construction. It provides a more efficient mixing of air and petrol, and its position, at the front of the engine clear of the exhaust manifold, minimises the possibility of vapour-locking.

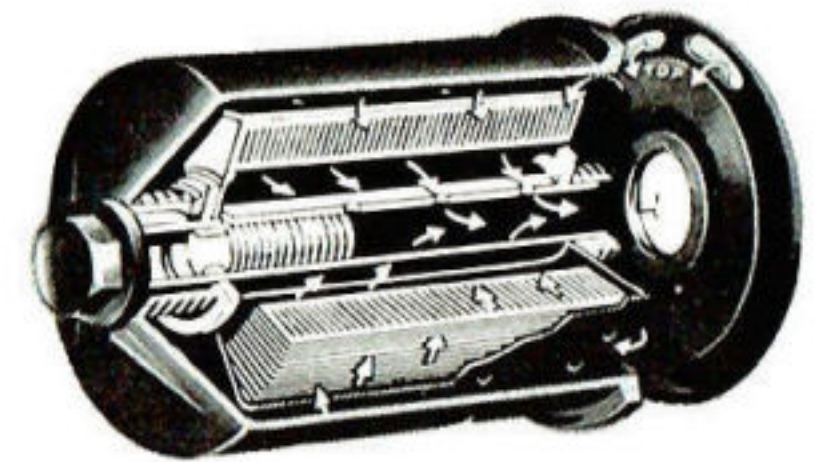

Full-flow Oil Filter

FULL-FLOW OIL FILTER cleans all oil before it reaches bearing surfaces, reducing cylinder wall and piston ring wear and contributing to long bearing and engine life. High capacity oil pump is of efficient gear type for positive discharge . . . quiet operation . . . long life . . . and has integral pressure-regulation valve.

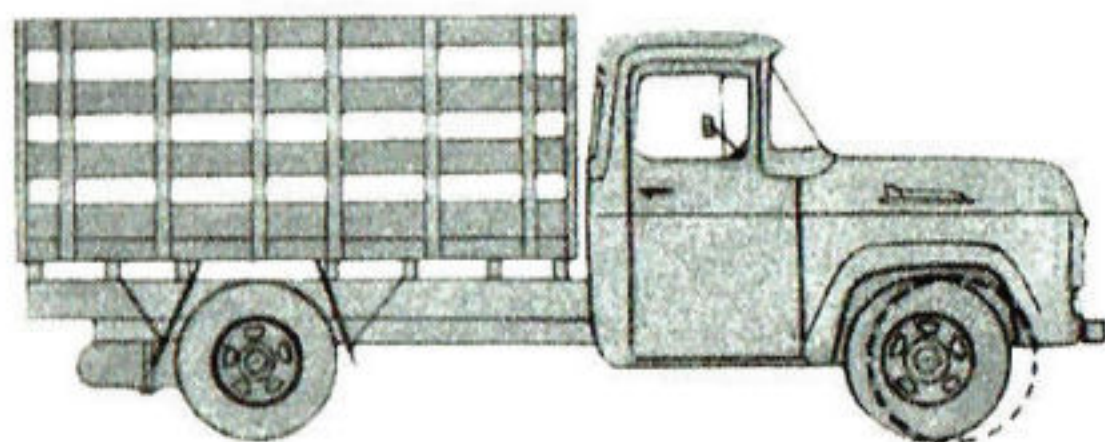

Big advantages in set-back front axle and wider track . . .

The front axle is moved back providing a shorter wheelbase with greater manoeuvrability. Body load centre is moved forward and larger-capacity front axle supports a larger share of the load for better weight distribution. Wider track provides increased stability, and also provides the greater handling ease of Ford's turning angle of up to 39 degrees.

FORD O.H.V. V8 TRUCKS

More usable power

More chassis strength

Lasts longer, too!

Abridged Specifications

FORD O.H.V. V8 TRUCKS

ENGINE:

V8 for high operating efficiency with push rod operated overhead valves operating in special alloy iron detachable cylinder heads. Short stroke engine design.

Bore 3.62 Stroke 3.30. Capacity 272 cubic inches. Compression ratio 7.1:1 R.A.C. and S.A.E rating 42.05 H.P. Maximum B.H.P. Gross 166 @ 4400 r.p.m. Net 139 @ 4200 r.p.m. Maximum torque: Gross 240 lbs. per ft. @ 2200-2600 r.p.m. Net 227 lbs. per ft. @ 1800-2400 r.p.m. Engine mounted at 4 points with rubber insulated bearers.

Cylinder block and crankcase cast in one piece, of high grade chrome-nickle alloy iron. Crankcase extends $2\frac{3}{4}$ " below centre of crankshaft for exceptional rigidity and better oil pan and crankcase sealing. 5 main bearing precision moulded alloy iron crankshaft. Each crankshaft is dynamically balanced to provide smooth engine performance and long engine life. Replaceable steel backed copper lead main and big end bearings.

PISTONS:

Tin-plated skirt aluminium alloy pistons of the autothermic design. Chrome plated top piston ring, phosphate coated lower compression ring and three piece oil control ring consisting of a serrated spring between two chrome plated rails that exert "triple pressure" for excellent oil control.

CYLINDER HEAD:

Special alloy iron cylinder heads have unusually uniform distribution of metal and water passages with improved circulation for efficient cooling and maximum stability. Made of the same high grade material as the cylinder block, they have the same rate of expansion and contraction with temperature variations, thus providing freedom from distortion and leakage.

ENGINE LUBRICATION:

High pressure from high capacity rota type pump with pressure feed to all main and camshaft bearings via drilled passages in engine block and to all connecting rod bearings through drilled leads in crankshaft.

OIL FILTRATION:

Full flow oil filtration through a replaceable cartridge type filter element. Filter assembly base mounted integral with cylinder block on lower left-hand side of engine completely eliminating external oil lines.

CRANKCASE VENTILATION:

Direct flow crankcase ventilation removes corrosive vapours by continuous circulation of clean air through the engine. Due to the location of the outlet, the system effects a self-induced flow of air so that ventilation does not depend wholly upon blast from fan and is perfected to the extent that the air flow is divided, firstly to the upper part of the engine around the rocker mechanism, then down to the crankcase, secondly around the timing chain and then to the crankcase.

OIL CAPACITY:

8 pints plus 1 pint for filter absorption.

FUEL:

Holley dual downdraught low silhouette carburettor with externally adjusted fuel level setting. Acceleration pump, diaphragm operated and power valve vacuum operated for maximum power with fuel economy performance. Manually controlled choke with stroke and throttle controls interconnected.

FUEL SUPPLY:

By mechanical pump, driven from engine camshaft. Special filter element fitted in glass bowl protects fuel supply to engine and is readily removable for periodic service or maintenance.

FUEL TANK CAPACITY:

14.5 Imperial gallons.

COOLING SYSTEM:

High capacity series flow cooling system resulting in direct water flow at high velocity from the front to rear of block on each bank then through connecting passages in the cylinder heads over each combustion chamber and back to the outlet at the front for closer temperature control and eliminating hot spots, with the consequent reduction of tendency for engine to detonate. Four-bladed fan, diameter 18 ins. with pressed steel cowling.

COOLING SYSTEM CAPACITY:

17.5 Imperial quarts.

ELECTRICAL:

Coil and distributor with combined centrifugal and vacuum control for automatic advance and retard. Conical tapered seat 18 mm. spark plugs. The conical tapered plug seat eliminates the need for gaskets and once the plug is properly tightened, no torque loss is encountered providing positive seating under high combustion pressures. 12-volt electrical system with dual headlighting system.

BATTERY:

12 volt 55 amp. per hr. capacity at 20 hr. rate. Negative terminal grounded.

CLUTCH:

Single dry disc type. Diameter 11 ins. Spring loaded centre for smooth drive. Frictional area 123.7 sq. ins.

GEARBOX:

Cast iron casing. Four forward one reverse speed standard equipment. Synchromesh on top, third and second. Constant mesh helical gears in top three speeds.

GEAR BOX RATIOS:

Four-speed—First 6.40:1 Second 3.09:1
Third 1.69:1 Fourth 1:1
Reverse 7.82:1

POWER TAKE OFF:

Six bolt S.A.E. Power take-off on right-hand side of transmission.

GEARBOX CAPACITY:

6.7 Imperial Pints.

DRIVE LINES:

Two open propeller shaft provides smooth flow of power from the transmission to the rear axle. All units of the drive line are carefully designed and installed in the chassis with the proper inclination to

produce straight line drive with minimum angularity between light and loaded positions.

REAR AXLE:

Full floating axle. Shafts forged integral with outer flanges. Axle shafts are chrome molybdenum steel forgings, heat-treated for toughness and high torsional strength. The rear axle utilises a hypoid type drive gear and pinion. Axle ratio—5.83:1.

FRONT AXLE:

Front axles feature high-strength, heat-treated forged alloy steel; axle centres of rigid I-beam type construction. Sections are increased at all high stress points. Reverse Elliot steering knuckles feature bolted-on stronger steering arms as well as stronger spindles.

FRAME:

Deep channel section side-members, parallel ladder-type frame construction. Cross members flanged "U" type with Alligator Jaw and Channel Sections. The parallel type frame allows installation of both engine and steering gear mechanism within the protection of side rails.

SPRINGS:

Semi-elliptic springs front and rear. Front springs are wide span with low deflection rate for desirable riding qualities and stability. The rear springs are long and wide for proper resilience and to carry the recommended load capacity under the most severe conditions.

Dimensions — Front: 45" x 2"
Rear: 52" x 2.5"

STEERING BOX:

Worm and roller-type steering gear design provides quick response to wheel, steady handling ease and rugged construction. Both worm and sector shaft are adjustable to provide long dependable service. The sector shaft in steering mechanism has a long bearing surface and bronze bushings. Steering gear ratio 20.4:1.

STEERING WHEEL:

Steel core with hard moulded rubber cover and grip. 18 in. diameter, centre horn button.

STEERING BALL SOCKETS:

Tie-rod ends are spring loaded, ball socket type for automatic take-up of normal ball-socket wear.

STEERING BOX CAPACITY:

.625 Imperial Pints.

TURNING CIRCLE DIAMETERS:

130" W/B 45.3' Right 44.5' Left
154" W/B 52.1' Right 50.0' Left
All measurements approximate—taken to centre line of outer wheel.

BRAKES:

Full hydraulic system, vacuum boosted, operated by pedal acting on front and rear wheels. Total area drum lining front and rear combined, 364.8 sq. ins.

HAND BRAKES:

Equalised Parking Brake operates the rear wheel brakes mechanically by means of

Abridged Specifications

FORD O.H.V. V8 TRUCKS

steel cables. An equaliser between the cables applies uniform pressure to each rear brake for straight-line emergency stops.

FRONT BRAKES:

Single anchor duo-servo self energising type.

Dimensions — (Drum diameter and lining width — thickness) 13" x 2 1/4" — 1/4".

REAR BRAKES:

Single anchor duo-servo self energising type.

Dimensions — (Drum diameter x lining width thickness) 15" x 4" — 3/8".

WHEELS AND TYRES:

Wheels are of the 2-piece pressed steel disc-type with split spring steel locking rings. Rim sizes — 5.0 x 20 — 7 wheels. Standard tyre equipment — front, rear. (All tube and tyre combination.)

Tyre sizes — 6 6.50 x 20 — 6 ply
6.50 x 20 — 8 ply (optional extra cost).

CAB:

All steel welded structure of 3 man design. Boxed section construction in windshield header and filler posts for maximum safety and durability.

CAB MOUNTING:

Rubber pads and rubber insulated bolts at each front corner and level-action links in torsion-type rubber bushings at rear corners, provide 4-point stability, insulating cab from vibration, noise and frame weave.

INSTRUMENT PANEL:

Curved panel with easy-to-read full vision instrument cluster containing fuel gauge, oil pressure and charge indicator lights, speedometer and temperature gauge.

DOORS:

All steel construction mounted on concealed goose-necked hinges. Door checks built into hinges hold doors in open position. Push button handles with rugged rota-type safety latches. Continuous weather stripping around doors with weather sealed Air Wing Vents.

WINDOWS:

Wrap-around windshield, full width rear window over 4 ft. wide, large door windows giving total glass area of 2100 sq. ins. for all-round visibility.

SEATING:

Full width seat with non-sag coil springs. Improved basic construction gives added support for back and knees. 4-inch finger tip seat adjustment. Cushion and back rest covered in durable Vinyl.

VENTILATION:

Hi-Dri cowl type ventilation. Air flow through cowl side panel vents fully controlled by controls on instrument panel.

CHASSIS EQUIPMENT:

Included as standard in addition to items mentioned above: Hood, cowl and dash assembly; front fenders; Hi-dri cowl ventilators; steel toe Board; Instrument panel; speedometer; water temperature gauge; oil pressure warning light; fuel gauge; ash receptacle; glove box; Horn; Electric windshield wipers; treadle-type accelerator pedal; long arm outside rear view mirror on chassis cab; internal sun visor; standard tools in bag, hydraulic jack.

Ford Motor Company of Australia Pty. Ltd., whose policy is one of continuous improvement, reserves the right, subject to such regulations as may from time to time apply, to change specifications and prices at any time without notice or incurring liability to purchasers.

GENERAL DIMENSIONS: F500, 2-tonner

Wheelbase	130"	154"
Track, Front	62.75	62.75
Track, Rear	66.5	66.5
Max. Overall Length (to end of frame)	204	228
Max. Height (to top of Cab — Loaded)	79.80	79.80
Max. Width of Vehicle (bumpers)	77.6	77.6
Max. Length along Loading Floor		
Max. Width across Loading Floor		
Max. Width above Wheel arches		
Max. Width inside Wheel Arches		
Across Loading Floor Max. Height of Sides from Loading Floor to Tonneau Cover		
Width of Tailgate Opening		
Width across Front seat	56.70	56.70
Back of Cab to End of Frame	99.02	123.02

} OWING TO THE VARIANCE BODY TYPES SPECIFICATIONS SUPPLIED ON REQUEST

CHASSIS DIMENSIONS

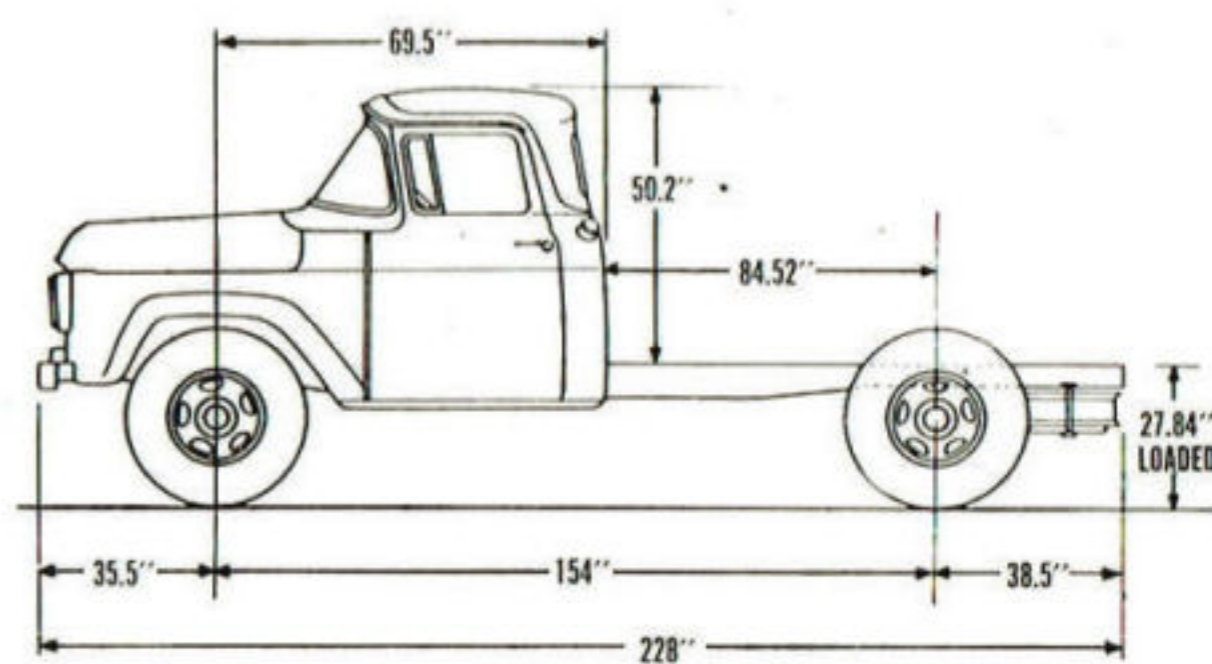
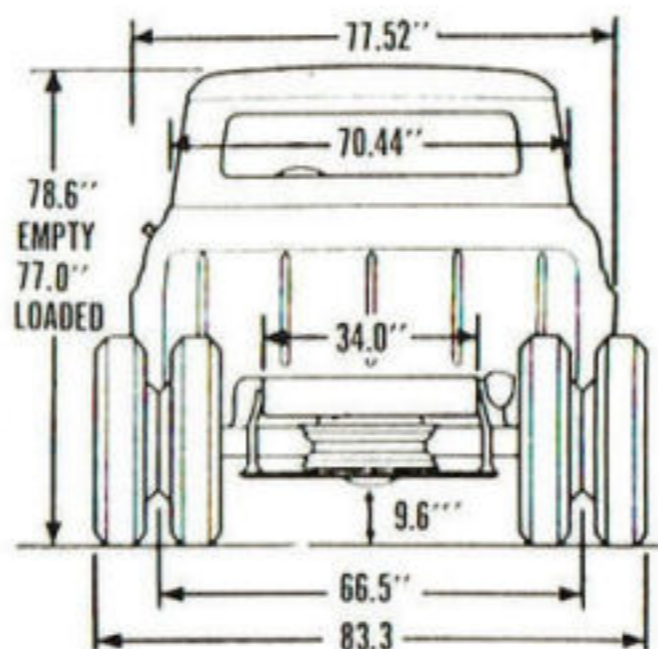
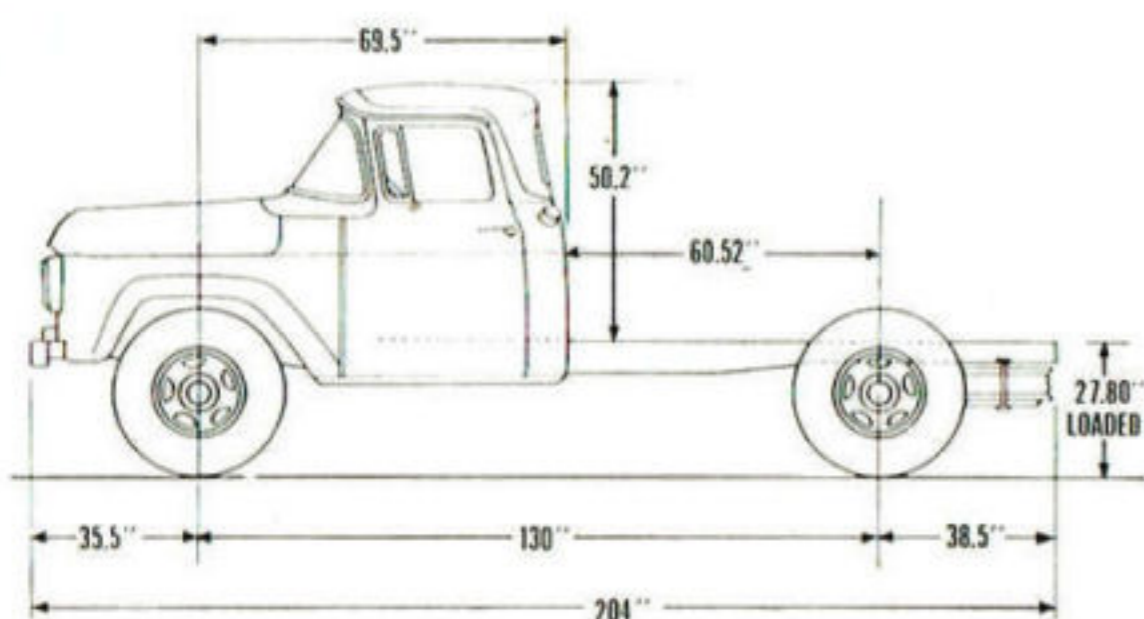

DM 37/59

FORD MOTOR COMPANY OF AUSTRALIA PTY. LTD.

(Incorporated in Victoria) Reg. Office: Geelong, Victoria

Abridged Specifications FORD O.H.V. V8 TRUCKS

ENGINE:
V8 for high operating efficiency with push rod operated overhead valves operating in special alloy iron detachable cylinder heads. Short stroke engine design.

Bore 3.62 Stroke 3.30. Capacity 272 cubic inches. Compression ratio 7.1:1 R.A.C. and S.A.E rating 42.05 H.P. Maximum B.H.P. Gross 166 @ 4400 r.p.m. Net 139 @ 4200 r.p.m. Maximum torque: Gross 240 lbs. per ft. @ 2200-2600 r.p.m. Net 227 lbs. per ft. @ 1800-2400 r.p.m. Engine mounted at 4 points with rubber insulated bearers.

Cylinder block and crankcase cast in one piece, of high grade chrome-nickel alloy iron. Crankcase extends 2 3/4" below centre of crankshaft for exceptional rigidity and better oil pan and crankcase sealing. 5 main bearing precision moulded alloy iron crankshaft. Each crankshaft is dynamically balanced to provide smooth engine performance and long engine life. Replaceable steel backed copper lead main and big end bearings.

PISTONS:
Tin-plated skirt aluminium alloy pistons of the autothermic design. Chrome plated top piston ring, phosphate coated lower compression ring and three piece oil control ring consisting of a serrated spring between two chrome plated rails that exert "triple pressure" for excellent oil control.

CYLINDER HEAD:
Special alloy iron cylinder heads have unusually uniform distribution of metal and water passages with improved circulation for efficient cooling and maximum stability. Made of the same high grade material as the cylinder block, they have the same rate of expansion and contraction with temperature variations, thus providing freedom from distortion and leakage.

ENGINE LUBRICATION:
High pressure from high capacity rota type pump with pressure feed to all main and camshaft bearings via drilled passages in engine block and to all connecting rod bearings through drilled leads in crankshaft.

OIL FILTRATION:
Full flow oil filtration through a replaceable cartridge type filter element. Filter assembly base mounted integral with cylinder block on lower left-hand side of engine completely eliminating external oil lines.

CRANKCASE VENTILATION:
Direct flow crankcase ventilation removes corrosive vapours by continuous circulation of clean air through the engine. Due to the location of the outlet, the system effects a self-induced flow of air so that ventilation does not depend wholly upon blast from fan and is perfected to the extent that the air flow is divided, firstly to the upper part of the engine around the rocker mechanism, then down to the crankcase, secondly around the timing chain and then to the crankcase.

OIL CAPACITY:
8 pints plus 1 pint for filter absorption.

FUEL:
Holley dual downdraught low silhouette carburettor with externally adjusted fuel level setting. Acceleration pump, diaphragm operated and power valve vacuum operated for maximum power with fuel economy performance. Manually controlled choke with stroke and throttle controls interconnected.

FUEL SUPPLY:
By mechanical pump, driven from engine camshaft. Special filter element fitted in glass bowl protects fuel supply to engine and is readily removable for periodic service or maintenance.

FUEL TANK CAPACITY:
14.5 Imperial gallons.

COOLING SYSTEM:
High capacity series flow cooling system resulting in direct water flow at high velocity from the front to rear of block on each bank then through connecting passages in the cylinder heads over each combustion chamber and back to the outlet at the front for closer temperature control and eliminating hot spots, with the consequent reduction of tendency for engine to detonate. Four-bladed fan, diameter 18 ins. with pressed steel cowling.

COOLING SYSTEM CAPACITY:
17.5 Imperial quarts.

ELECTRICAL:
Coil and distributor with combined centrifugal and vacuum control for automatic advance and retard. Conical tapered seat 18 mm. spark plugs. The conical tapered plug seat eliminates the need for gaskets and once the plug is properly tightened, no torque loss is encountered providing positive seating under high combustion pressures. 12-volt electrical system with dual headlighting system.

BATTERY:
12 volt 55 amp. per hr. capacity at 20 hr. rate. Negative terminal grounded.

CLUTCH:
Single dry disc type. Diameter 11 ins. Spring loaded centre for smooth drive. Frictional area 123.7 sq. ins.

GEARBOX:
Cast iron casing. Four forward one reverse speed standard equipment. Synchronism on top, third and second. Constant mesh helical gears in top three speeds.

GEAR BOX RATIOS:
Four-speed—First 6.40:1 Second 3.09:1
Third 1.69:1 Fourth 1:1
Reverse 7.82:1

POWER TAKE OFF:
Six bolt S.A.E. Power take-off on right-hand side of transmission.

GEARBOX CAPACITY:
6.7 Imperial Pints.

DRIVE LINES:
Two open propeller shaft provides smooth flow of power from the transmission to the rear axle. All units of the drive line are carefully designed and installed in the chassis with the proper inclination to

produce straight line drive with minimum angularity between light and loaded positions.

REAR AXLE:
Full floating axle. Shafts forged integral with outer flanges. Axle shafts are chrome molybdenum steel forgings, heat-treated for toughness and high torsional strength. The rear axle utilises a hypoid type drive gear and pinion. Axle ratio—5.83:1.

FRONT AXLE:
Front axles feature high-strength, heat-treated forged alloy steel; axle centres of rigid I-beam type construction. Sections are increased at all high stress points. Reverse Elliot steering knuckles feature bolted-on stronger steering arms as well as stronger spindles.

FRAME:
Deep channel section side-members, parallel ladder-type frame construction. Cross members flanged "U" type with Alligator Jaw and Channel Sections. The parallel type frame allows installation of both engine and steering gear mechanism within the protection of side rails.

SPRINGS:
Semi-elliptic springs front and rear. Front springs are wide span with low deflection rate for desirable riding qualities and stability. The rear springs are long and wide for proper resilience and to carry the recommended load capacity under the most severe conditions.

Dimensions — Front: 45" x 2"
Rear: 52" x 2.5"

STEERING BOX:
Worm and roller-type steering gear design provides quick response to wheel, steady handling ease and rugged construction. Both worm and sector shaft are adjustable to provide long dependable service. The sector shaft in steering mechanism has a long bearing surface and bronze bushings. Steering gear ratio 20.4:1.

STEERING WHEEL:
Steel core with hard moulded rubber cover and grip. 18 in. diameter, centre horn button.

STEERING BALL SOCKETS:
Tie-rod ends are spring loaded, ball socket type for automatic take-up of normal ball-socket wear.

STEERING BOX CAPACITY:
.625 Imperial Pints.

TURNING CIRCLE DIAMETERS:
130" W/B 45.3' Right 44.5' Left
154" W/B 52.1' Right 50.0' Left
All measurements approximate—taken to centre line of outer wheel.

BRAKES:
Full hydraulic system, vacuum boosted, operated by pedal acting on front and rear wheels. Total area drum lining front and rear combined, 364.8 sq. ins.

HAND BRAKES:
Equalised Parking Brake operates the rear wheel brakes mechanically by means of

Abridged Specifications FORD O.H.V. V8 TRUCKS

steel cables. An equaliser between the cables applies uniform pressure to each rear brake for straight-line emergency stops.

FRONT BRAKES:
Single anchor duo-servo self energising type. Dimensions — (Drum diameter and lining width — thickness) 13" x 2 1/4" — 1/4".

REAR BRAKES:
Single anchor duo-servo self energising type. Dimensions — (Drum diameter x lining width thickness) 15" x 4" — 3/8".

WHEELS AND TYRES:
Wheels are of the 2-piece pressed steel disc-type with split spring steel locking rings. Rim sizes — 5.0 x 20 — 7 wheels. Standard tyre equipment — front, rear. (All tube and tyre combination.)
Tyre sizes — 6 6.50 x 20 — 6 ply
6.50 x 20 — 8 ply (optional extra cost).

CAB:
All steel welded structure of 3 man design. Boxed section construction in windshield header and filler posts for maximum safety and durability.

CAB MOUNTING:
Rubber pads and rubber insulated bolts at each front corner and level-action links in torsion-type rubber bushings at rear corners, provide 4-point stability, insulating cab from vibration, noise and frame weave.

INSTRUMENT PANEL:
Curved panel with easy-to-read full vision instrument cluster containing fuel gauge, oil pressure and charge indicator lights, speedometer and temperature gauge.

DOORS:
All steel construction mounted on concealed goose-necked hinges. Door checks built into hinges hold doors in open position. Push button handles with rugged rota-type safety latches. Continuous weather stripping around doors with weather sealed Air Wing Vents.

WINDOWS:
Wrap-around windshield, full width rear window over 4 ft. wide, large door windows giving total glass area of 2100 sq. ins. for all-round visibility.

SEATING:
Full width seat with non-sag coil springs. Improved basic construction gives added support for back and knees. 4-inch finger tip seat adjustment. Cushion and back rest covered in durable Vinyl.

VENTILATION:
Hi-Dri cowl type ventilation. Air flow through cowl side panel vents fully controlled by controls on instrument panel.

CHASSIS EQUIPMENT:
Included as standard in addition to items mentioned above: Hood, cowl and dash assembly; front fenders; Hi-dri cowl ventilators; steel toe Board; Instrument panel; speedometer; water temperature gauge; oil pressure warning light; fuel gauge; ash receptacle; glove box; Horn; Electric windshield wipers; treadle-type accelerator pedal; long arm outside rear view mirror on chassis cab; internal sun visor; standard tools in bag, hydraulic jack.

Ford Motor Company of Australia Pty. Ltd., whose policy is one of continuous improvement, reserves the right, subject to such regulations as may from time to time apply, to change specifications and prices at any time without notice or incurring liability to purchasers.

GENERAL DIMENSIONS: F500, 2-tonner

Wheelbase	130"	154"
Track, Front	62.75	62.75
Track, Rear	66.5	66.5
Max. Overall Length (to end of frame)	204	228
Max. Height (to top of Cab — Loaded)	79.80	79.80
Max. Width of Vehicle (bumpers)	77.6	77.6
Max. Length along Loading Floor		
Max. Width across Loading Floor		
Max. Width above Wheel Arches		
Max. Width inside Wheel Arches		
Across Loading Floor: Max. Height of Sides from Loading Floor to Tonneau Cover	OWING TO THE VARIANCE BODY TYPES SPECIFICATIONS SUPPLIED ON REQUEST	
Width of Tailgate Opening		
Width across Front seat	56.70	56.70
Back of Cab to End of Frame	99.02	123.02

CHASSIS DIMENSIONS

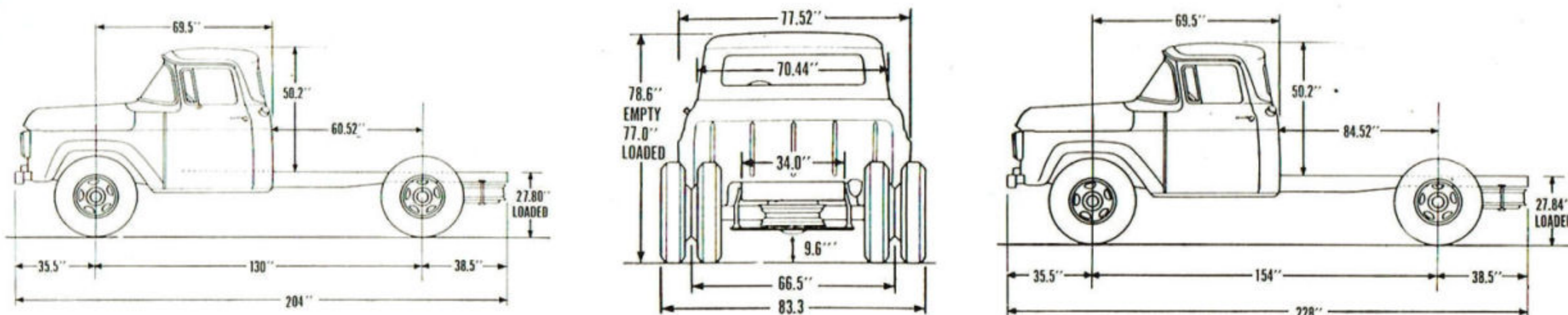

FORD MOTOR COMPANY OF AUSTRALIA PTY. LTD.
(Incorporated in Victoria) Reg. Office: Geelong, Victoria

NEW FORD

MONEY-MAKERS

F500

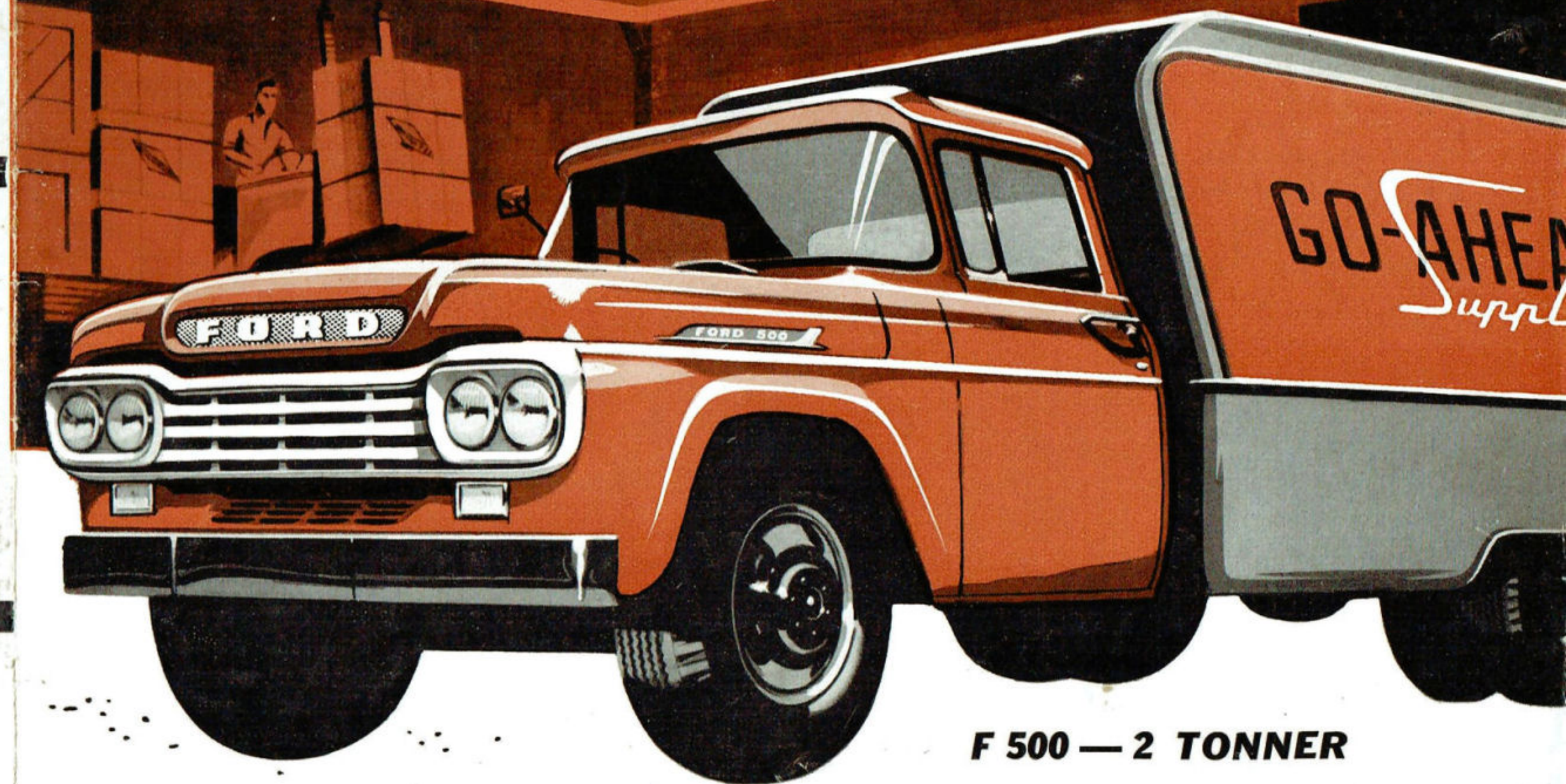

F 500 — 2 TONNER

FORD O.H.V. V8 TRUCKS

Money-saving O.H.V. V8 power

Ford's O.H.V. V8 engine gives you the fullest benefit of modern Short Stroke design. Thanks to Ford's Short Stroke design, pistons travel shorter distances, at slower speeds — resulting in less wear, less power-wasting friction, and more usable power is delivered to the wheels to do your

job. In addition, moving parts last longer to keep operating costs lower! And Deep-Block construction gives greater rigidity for long life and dependable performance. This is the most efficient V8 truck engine Ford has ever built, and Ford has built more V8 engines than any other manufacturer.

Precision-moulded rocker arms for greatest durability.

Free-turn valves (both intake and exhaust) for self-cleaning, better seating, longer life.

High-turbulence combustion chambers with higher compression for greater power output.

Full-floating piston pins for longer life.

Aluminium alloy autothermic pistons with steel struts for best performance.

Full-length water jackets reduce wear. Higher capacity water pump increases cooling at low speeds.

Long-lived, copper-lead main and connecting rod bearings.

Deep engine block for greater structural rigidity, smoother engine performance.

Larger short-reach intake manifold for quick, uniform fuel charge, easy starting.

Integral valve guides enable valves to run cooler, last 50% longer.

18-mm. "Turbo-Action" spark plugs — A Ford First, resist fouling with light loads, prolong peak power at full load.

Chrome-plated top ring prevents scuffing during break-in.

High-lift camshaft for wide valve opening.

Full-flow filter cleans all the oil, lengthens engine life.

Full-pressure lubrication of all crankshaft and connecting rod bearings for longer life.

High-capacity oil pump for positive lubrication, long life.

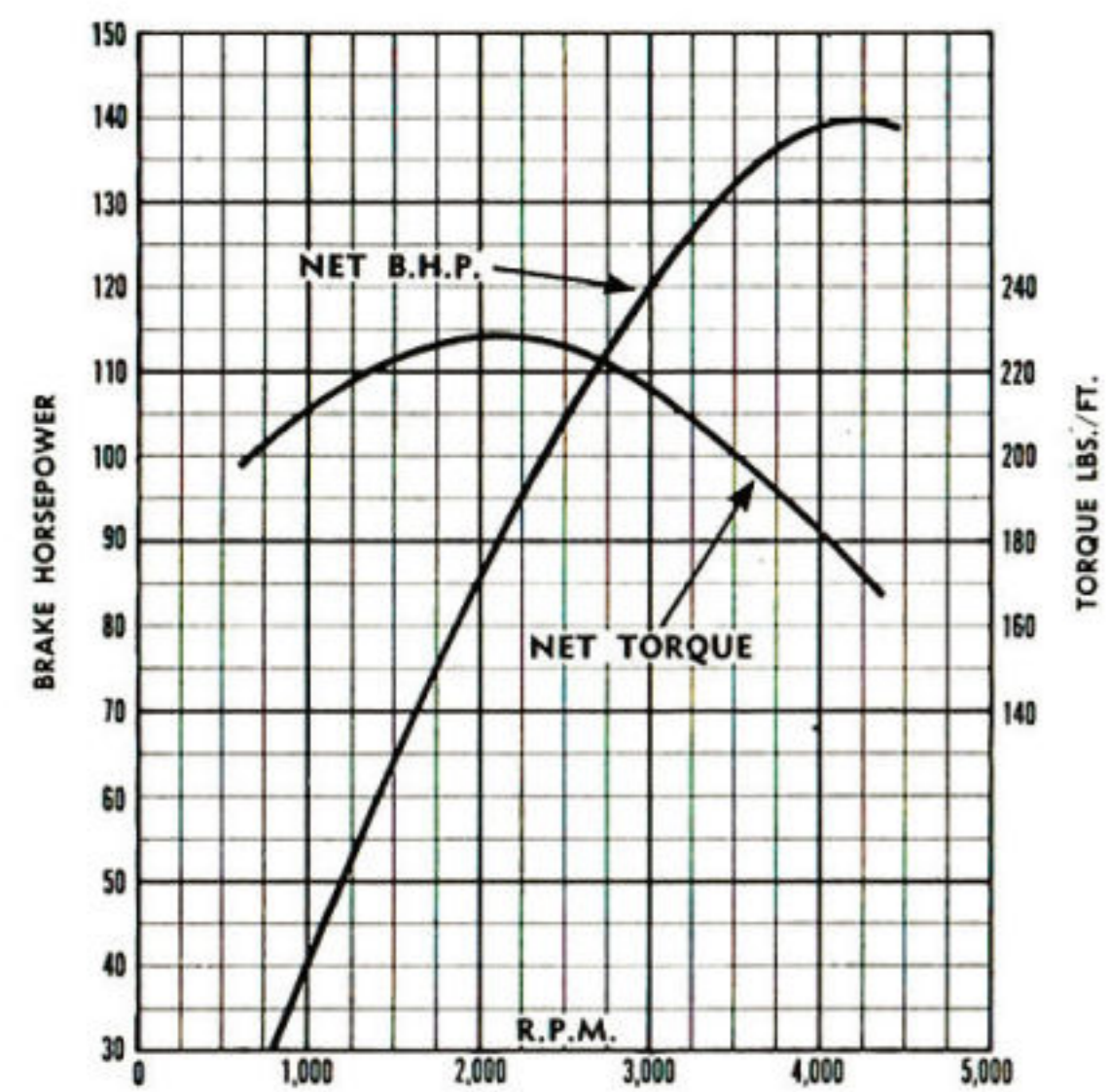
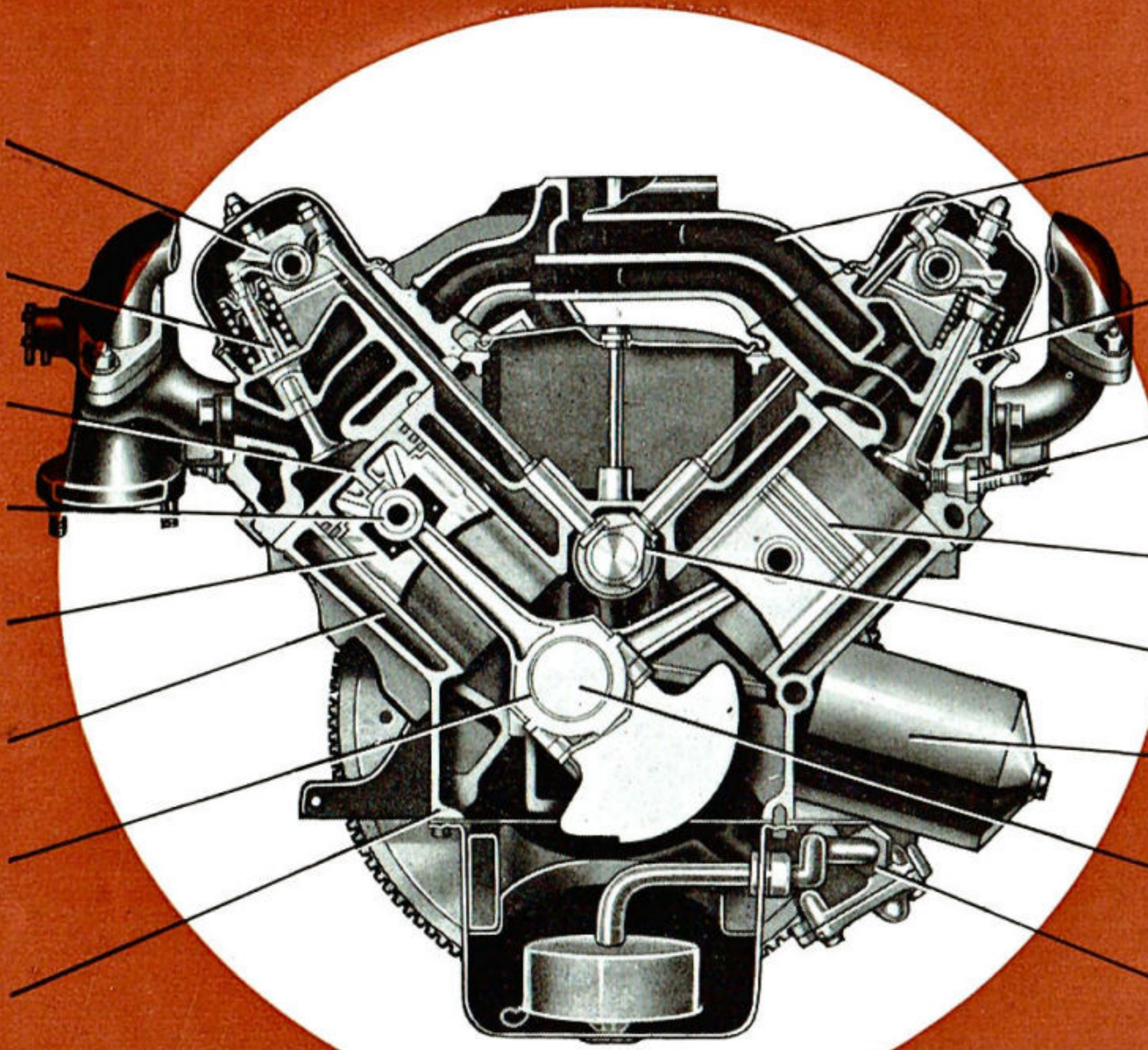

...plus the highest torque and b.h.p. in its field!

Here is far more horsepower per cubic inch displacement, and higher, more sustained torque for tough work, long hauls, and easier cruising speeds under heavy load conditions. Net maximum b.h.p. is 139 @ 4,200 r.p.m., and the high net torque of 227 ft. lbs. is attained at the low revolutionary rate of 2,200 r.p.m. Other reasons why Ford gives you more horsepower per pound are . . . 7.1:1 compression ratio . . . 12-volt electrical system . . . iron-alloy camshaft . . . exceptionally rigid crankshaft . . . and many other engineering advances.

Greatest cab value ever — with the most in comfort, safety, and convenience

Ford Driverized Cabs are big, comfortable, and extra strong. Features are engineered in to reduce fatigue, lessen tension, and provide the nearest ride yet to sedan-like comfort.

- 1 Full wrap-around windscreen.** Now there's 1,020 square inches in Ford's wider, full wrap-around windscreen. Vision is unobstructed forward, down and to the sides.
- 2 Look at the dimensions.** There's no squeeze in this cab . . . there's more shoulder room, leg room and added head room to make driving-comfort and passenger-comfort more relaxing, less fatiguing.
- 3 Inboard step.** Ford has moved the cab step up inside the door making it easier to climb aboard. It provides extra protection against water and slush—increases over-all cab strength.
- 4 Doors open wide.** Doors open almost a full yard wide—are held open by door checks. It's the easiest cab to get into and out of on the road.
- 5 Complete weather sealing.** Doors and wing vents are completely encircled by tight fitting rubber seals . . . keeping out dust, fumes, moisture and draughts.

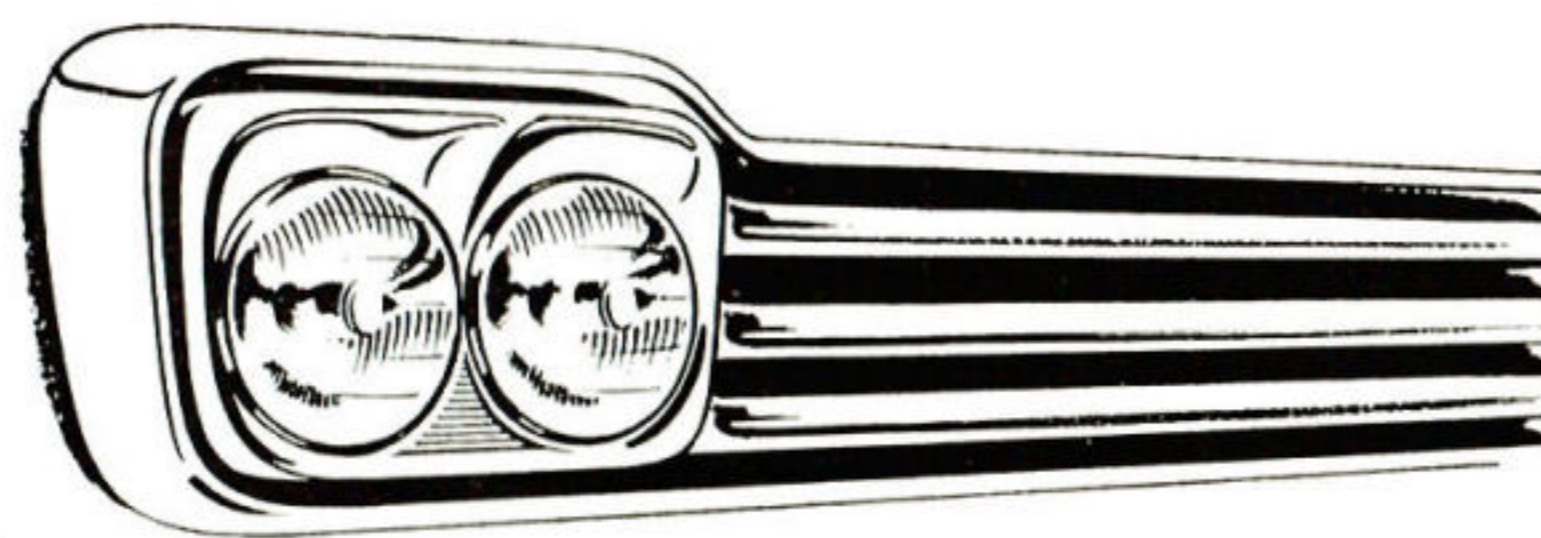
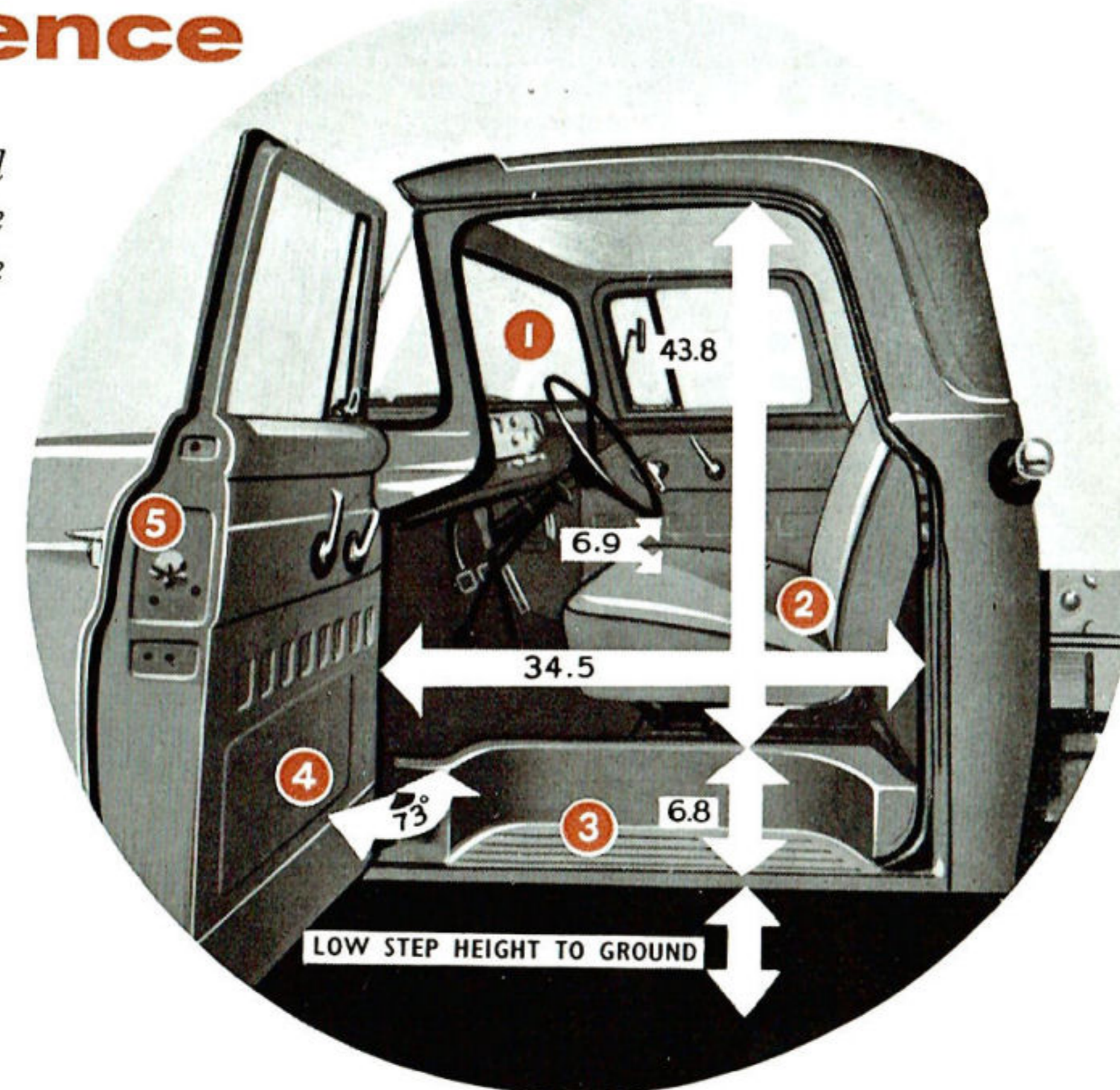

Dual headlights for safety and smartness

The dual headlight system on all Ford V8 trucks present a major improvement in lighting efficiency together with positive lighting control for added safety. Long range driving lights utilize four fixed filaments — one in each headlamp lens. The dipped beam has fixed focus spread pattern control in the outboard lights only, giving improved low-beam visibility.

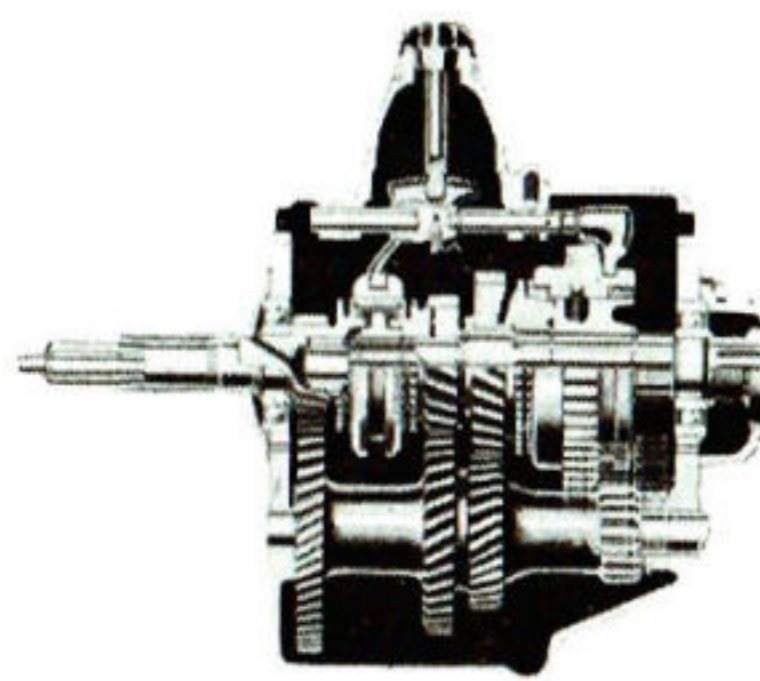

4-SPEED HEAVY DUTY SYNCHRO-SILENT TRANSMISSION

Standard equipment, it provides more "pulling" ability plus more flexible and economical operation with heavy loads than 3-speed transmissions.

Eliminates "Double-clutching", provides more safety in down shifting. One-piece clutch and fly wheel housing provides smoother, more reliable power flow and more strength for longer life.

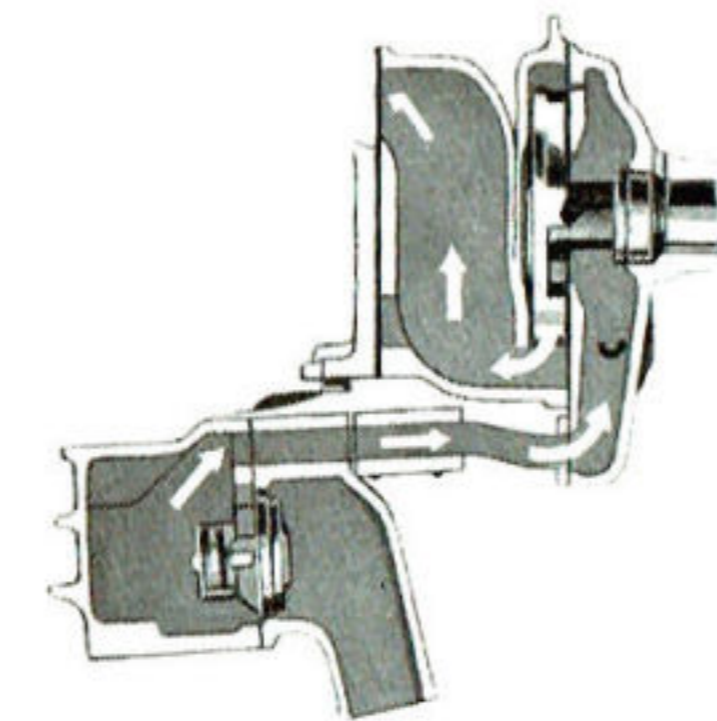

High capacity water pump

Ford's highly efficient water pump increases the water flow, reducing the possibility of heating at low speed or idling. The positive-action thermostat is unaffected by varying pressures, and constantly regulates the coolant.

Ford's rugged chassis design cuts ton mile costs!

Parallel ladder-type frame construction features heavy gauge channel side members and flanged "U" type cross members. Frames are of SAE standard 34" width to facilitate mounting of standard or custom-built bodies. Deep, wide-flanged side members extend beyond the front cross member to permit direct attachment of the front bumper which also serves as a cross member. And all cross members are strategically placed in frames to resist torsional stress.

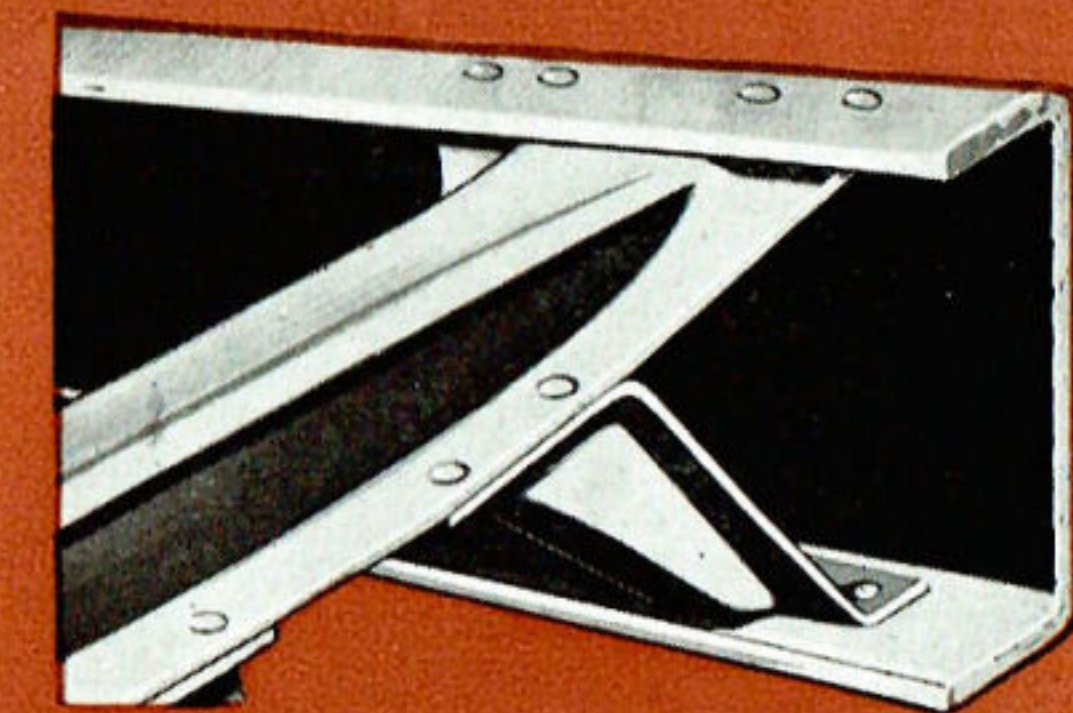

Wheelbases	Max. Side Rail Section	Section Modulus	Number of Cross Members
130"	7.08" x 2.77" x 0.25"	6.24"	5
154"	9.25" x 2.94" x 0.25"	9.45"	6

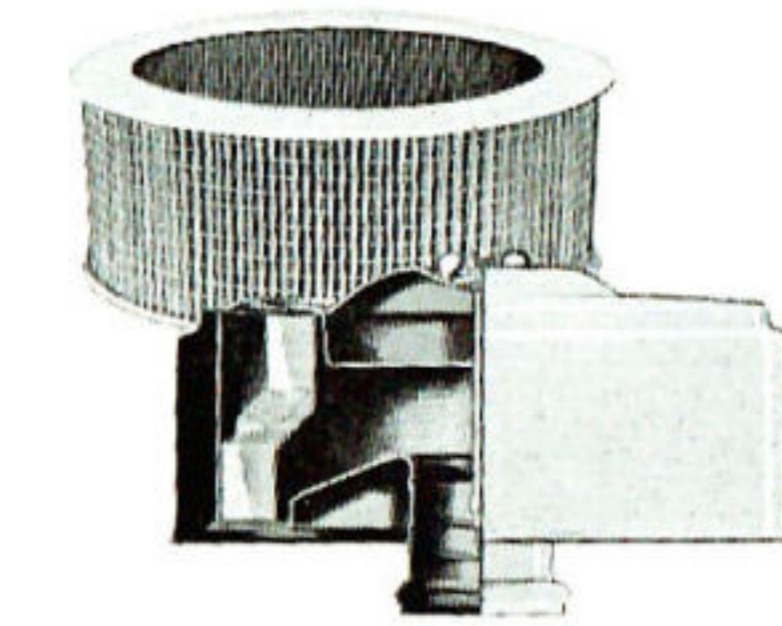

New Super Air Cleaner

Ford's new dry element Air Cleaner is pleated in accordion-fashion and is up to 90% more efficient than the oil-bath type cleaner. The filter is re-usable too, cleaning being easily accomplished by removing the element from housing and tapping firmly on a flat surface.

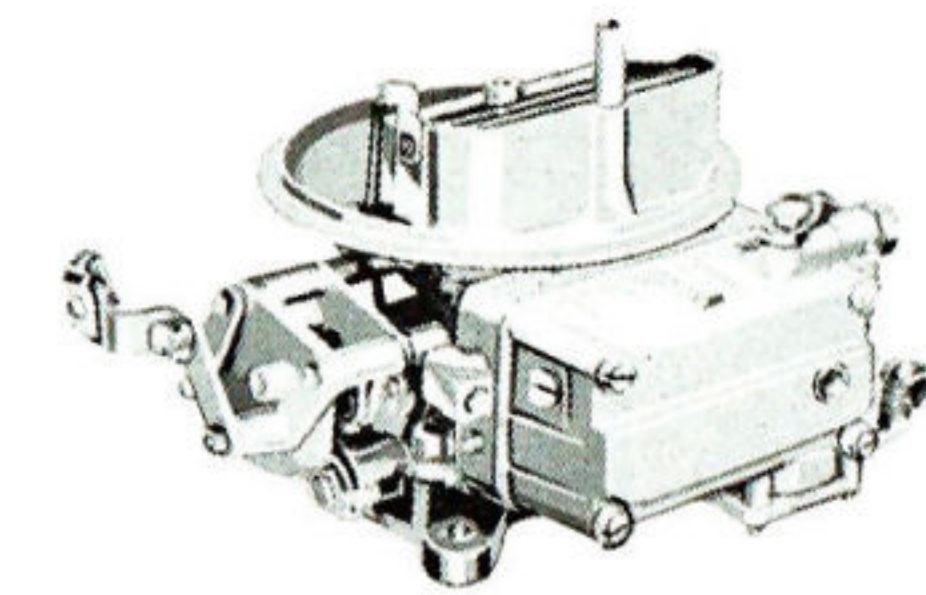

New Carburettor

The new dual-venturi carburettor is of low silhouette type—unique for its compactness and convenient unit construction. It provides a more efficient mixing of air and petrol, and its position, at the front of the engine clear of the exhaust manifold, minimises the possibility of vapour-locking.

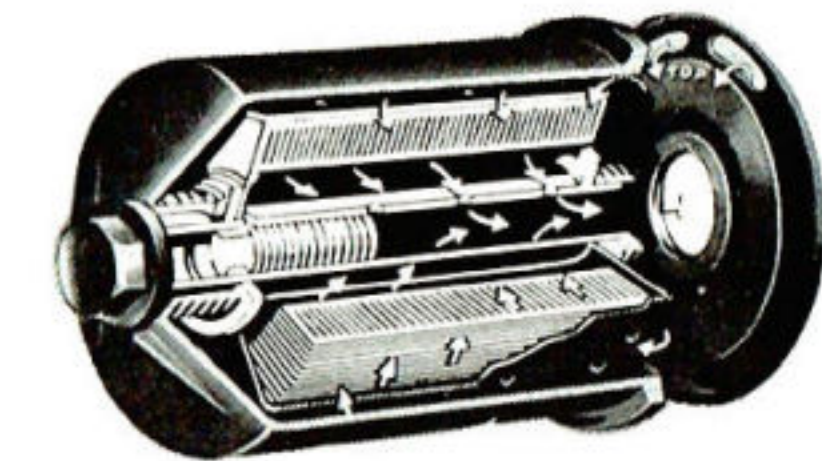

Full-flow Oil Filter

FULL-FLOW OIL FILTER cleans all oil before it reaches bearing surfaces, reducing cylinder wall and piston ring wear and contributing to long bearing and engine life. High capacity oil pump is of efficient gear type for positive discharge . . . quiet operation . . . long life . . . and has integral pressure-regulation valve.

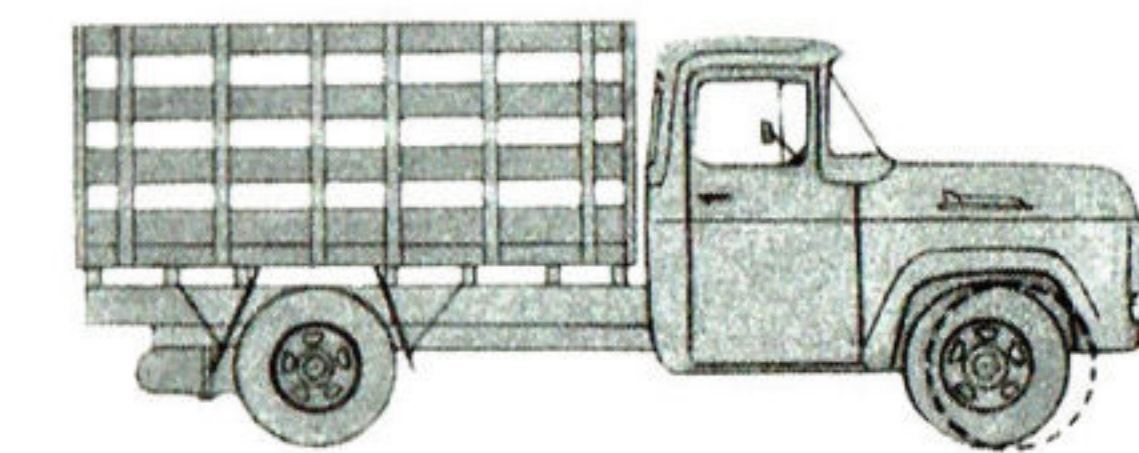

Big advantages in set-back front axle and wider track . . . The front axle is moved back providing a shorter wheelbase with greater manoeuvrability. Body load centre is moved forward and larger-capacity front axle supports a larger share of the load for better weight distribution. Wider track provides increased stability, and also provides the greater handling ease of Ford's turning angle of up to 39 degrees.

FORD
O.H.V. V8 TRUCKS

More usable power
More chassis strength
Lasts longer, too!