

AUSTRALIA'S MOST CARE-FREE CAR

AUSTRALIA'S BEST-SELLING FINE CAR

Fairlane 500 — Australia's biggest-selling fine car — is now even finer for '63.

As you see on the left, it has a clean new look of action.

Out on the road — you'll find that even Fairlane's previous unequalled smoothness of ride and handling ease have been made even better.

You'll experience, too, the greatest performance-team ever built into a car of Fairlane's size and price — a dynamic new 'Challenger 260'* V8 engine perfectly in tune with the world's best-known and smoothest of all automatics — Fordomatic Drive.

Inside, there are even richer, more luxurious interiors, with deep pleated seats, new fabrics and, of course, Fairlane's generous room for six people.

Fairlane's care-free features promise service savings, mile after mile. (You'll read all about them when you turn this page.)

Only Ford brings you a car so fine, at a price so low. See and drive the 1963 Fairlane 500 at your Ford Dealer's now! You'll find Fairlane 500 ownership a most rewarding experience.

'63 FORD FAIRLANE 500

*Optional extra cost. Whitewall tyres, shown, also optional extra cost.

1963 FORD FAIRLANE 500

Australia's most carefree car . . . Australia's best-selling fine car.

beautifully built to take care of itself . . .

Fairlane 500 is Australia's most care-free car, its unique take-care-of-itself features mean the average Fairlane owner will normally need to see his Ford Dealer only twice a year for maintenance.

1. It lubricates itself. New nylon bearings and a newly developed grease let you go 36,000 miles between lubrications of major chassis components such as suspension, steering-linkage, front wheel bearings and universal joints.

2. It adjusts its own brakes. The carefree Fairlane 500 adjusts its own brakes, too, for safer driving, less maintenance . . . no need to have brakes mechanically adjusted for the life of the linings.

luxury . . . that opens a new world of elegance . . .

Fine yarns are woven together in Fairlane's brocade upholstery material — selected to give the 1963 Fairlane interiors a high-fashion look of contemporary elegance. Color-matched vinyls are painstakingly tested to prove their durability. All upholstery is meticulously fitted,

quality . . . that is unsurpassed in the industry . . .

With the pride and pleasure of driving a new Ford Fairlane 500 comes the satisfaction of knowing that here is a car built to meet the most exacting standards. From drafting board to assembly line, careful attention is devoted to detail. Only high-quality materials and the most

3. It cleans its own oil. Fairlane 500's full-flow filtering system allows you to go 6,000 miles between oil changes.

4. It protects its own body. All Fairlane's vital under body parts are specially processed to resist rust and corrosion — even the body panels beneath the doors are galvanized.

5. It takes care of its own finish. Fairlane's lustrous new baked-enamel finish lasts and lasts. Just wash it and it shines like new.

6. It's protected by Ford's 12/12 warranty. Ford Dealers give a 12-month or 12,000-mile warranty, whichever comes first, with Fairlane 500. Simple proof that Fairlane 500 is built for reliability . . . built for keeps.

assuring tailored luxury. Spacious comfort is provided for both front and rear seat passengers. Appointments include wall-to-wall carpeting, electric clock, color-keyed steering wheel plus many other items to add to your convenience and driving pleasure.

up-to-date manufacturing techniques go into the new Fairlane 500 . . . and continuous inspections, tests and evaluations throughout every phase of design, production and assembly result in a quality-crafted car, for your lasting pleasure now, and for many miles to come.

power . . . that sets a new standard for performance . . .

You have your choice of two Ford V8 engines — the Challenger "221" V8 (standard), and the really hot-performing Challenger "260" V8 (optional extra cost). The extra measure of performance engineered into the Challenger "260" V8 makes it the finest performing V8 available — puts you in command of *any* driving situation.

It combines rocketing power with luxurious smoothness and quietness to please the most exacting performance fan. At the same time it provides exceptionally high economy for an engine of its capacity . . . you'll enjoy *both* action *and* economy in this lively, liquid-smooth power plant.

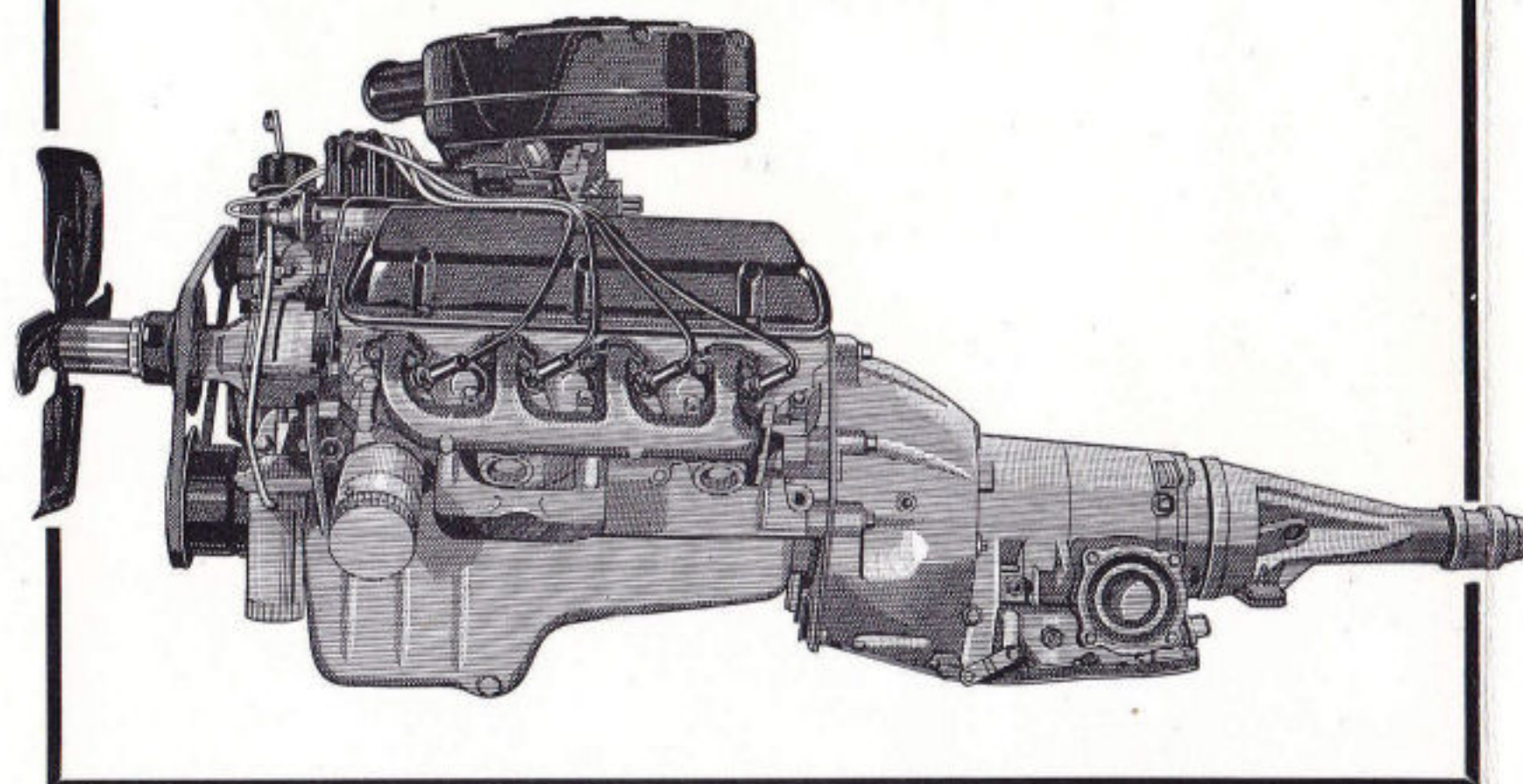

world-famous Fordomatic Drive

Only Fairlane 500 has it in the big-car field — Fordomatic Drive with the world's finest reputation for efficiency, smoothness, and "flowing" power. It's *standard* equipment on Fairlane 500 . . . and when teamed with the Challenger "260" V8 provides a standard of driving-ease and motoring enjoyment that can't be equalled by any other car irrespective of price.

SPECIFICATIONS



FAIRLANE DESIGN. Welded integral body and frame, quietness and high-strength weight ratio. Completely sealed and insulated. Special torque boxes at each corner of the main underbody structure absorb road shock, sound and vibrations. Safety-reinforced roof with sturdy cross braces at front, centre and rear. Zinc coated rocker panels and main underbody members for extra long life. Bolt on front fenders for reduced replacement cost. Rear hinged, counter-balanced hood with outside safety latch. Corrosion resistant anodized aluminium grill. Cowl-top ventilation system. Wide angle windshield with forward slanting pillars. Large wide-opening doors with bronze-bushed hinges, automatic assist springs on all doors. Double yoke safety door locks. Posture control front seat, adjustable to eight positions in 4" travel. 29 cubic feet luggage compartment with counter balanced boot lid. 13 $\frac{3}{4}$ gallon petrol tank, at rear.

ENGINES: 145 h.p. Challenger V8 — 221 cubic inch displacement. 3.50" bore. 2.87" stroke; 8.7:1 compression ratio premium fuel, two barrel carburettor, automatic choke, oil capacity with filter change 4.0 quarts.

OPTIONAL: 164 h.p. Challenger V8 — 260 cubic inch displacement. 3.80". 2.87" stroke; 8.7:1 compression ratio; premium fuel, two barrel carburettor, automatic choke, oil capacity with filter change — 4 quarts.

ENGINE FEATURES. For greater economic and longer life Fairlane engines have short stroke, low friction design; wedged type combustion chambers, hydraulic lifters for automatic valve adjustment; alternate intake and exhaust ports; water jacketed carburettor spacer for fuel mixture heat control; three ring aluminium alloy pistons with full chromed top ring and heat dam groove above top ring; precision moulded crankshaft with four main bearings; rotor type oil pump; super air cleaner with re-usable dry-type elements, high-capacity in-line 36,000 mile fuel filtering system; full-pressure lubrication system with full-flow disposal-type oil filter; cooling system with 180°F positive-action thermostat; 12 volt electrical system; weatherproof ignition with static-ban constant resistance wiring and ventilated distributor points; 18 m.m. turbo-action spark plugs; 54 plate, 40 amp. hr. battery; positive engagement starter; fully aluminized muffler.

FORDOMATIC DRIVE. Improved design, lightweight cast aluminium construction, minimum servicing. Torque con-

verter in combination with planetary gear set; transmission fluid water-cooled vacuum controlled throttle valve in transmission for smoother, more precisely co-ordinated shifting and reduced maintenance requirements. Two forward speeds, one reverse. Gear ratios (to 1) low 1.82, direct 1.00, reverse 1.75. Selector lever and quadrant on instrument panel; sequence P, R, N, D, L. In "D" range Fordomatic gives brisk, smooth starts in low ratio. Effective engine braking in "L" position.

REAR AXLE. Semi-floating type with offset hypoid gears, straddle-mounted drive pinion. Induction-hardened forged shafts with permanently lubricated bearings. Axle ratio 3.00:1.

FRONT SUSPENSION. Angle-poised ball-joint design with coil springs mounted on upper arms. Strut-stabilized lower arms. Ball joints packed with special 36,000 mile lubricant retained by long life seals. Built-in anti-dive control. Internally mounted double-acting hydraulic shock absorbers with rebound cutoff. Link-type, rubber-bushed ride stabilizer. Tapered roller wheel bearings lubricated for 36,000 miles.

REAR SUSPENSION. Longitudinal, semi-elliptic leaf springs with rubber-bushed front eye and compression-type rear shackles, giving variable-rate characteristics for a softer, more levelized ride under all road and load conditions. Asymmetrical design with rear axle located forward from centre of springs for anti-squat control on take-off. Rubber insulation at axle. Spring tip liners between all but bottom leaves—no lubrication required. Diagonally mounted double-acting shock absorbers.

STEERING. Low-friction, recirculating ball-type steering gear for easy steering. Flexible steering shaft coupling; dampens road shock vibration. Anti-friction bearings throughout. Steering-linkage system lubricated for 36,000 miles. Overall steering ratio 27.6 to 1. Turning diameter 39.5 ft.

BRAKES. Single anchor, self-adjusting, internal expanding, self energizing hydraulic brakes of double-sealed design. Easy operating suspended pedal. Dash-mounted master cylinder. Grooved 10" composite drums for maximum cooling. Total lining area 154.2 sq. in. Offset "T" handle parking brake at right of steering column.

TYRES. 7.00 x 14 — 4 ply.

DIMENSIONS. Wheelbase 115.5". Tread — front 57", rear 56". Overall length 197", Height 55.5". Overall width 71.3".

The specifications contained herein were in effect at the time this catalogue was approved for printing. Ford Motor Company of Australia Pty. Ltd., whose policy is one of continuous improvement, reserves the right, subject to such regulations as may from time to time apply, to change specifications and prices at any time without notice or incurring liability to purchasers. Some of the items illustrated or referred to are optional at extra cost.

FAIRLANE 500 DIMENSIONS

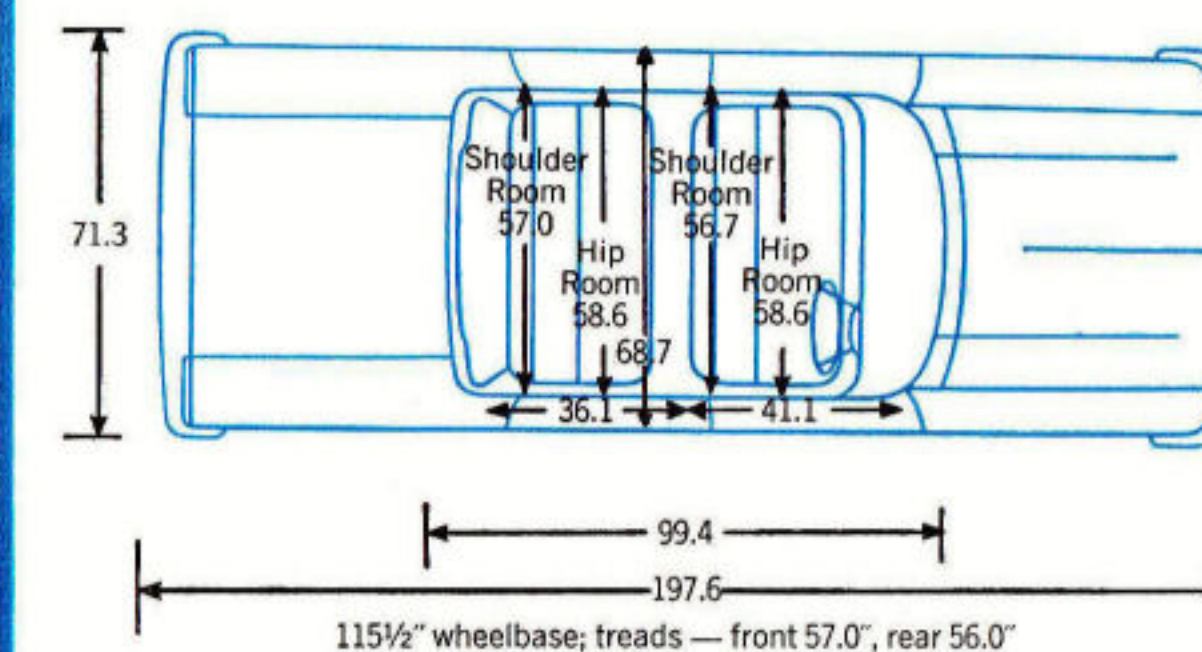
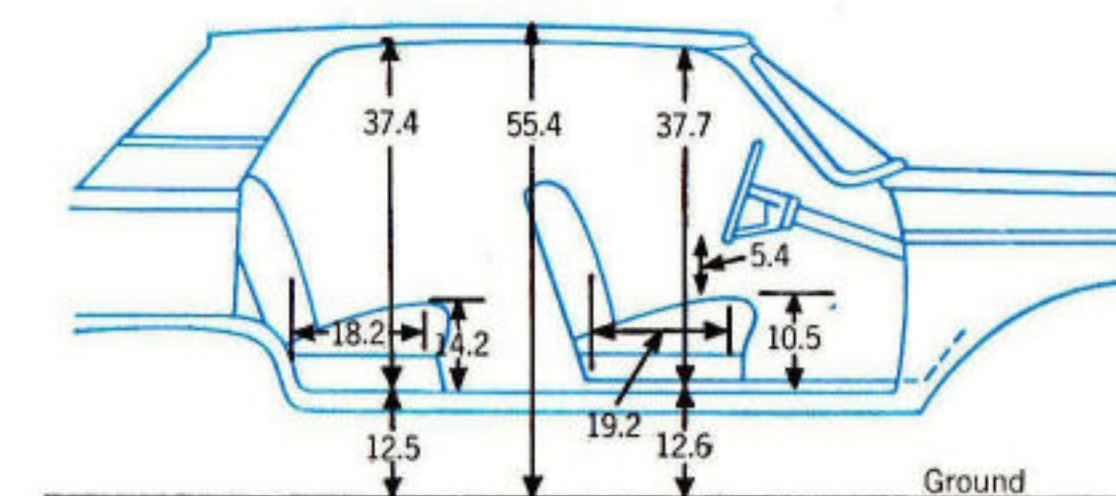

FORD 12/12 WARRANTY

One of the rewards of fine-car craftsmanship is the Ford 12/12 warranty which automatically goes with Fairlane 500. For 12,000 miles or 12 months, whichever comes first, your Fairlane 500 is warranted against faulty workmanship and materials. This covers both parts and labour. You remain responsible during this period only for normal maintenance service and the routine replacement of maintenance items.

DM 51—1/63

FORD MOTOR COMPANY OF AUSTRALIA PTY. LTD.
Shell Corner, 155 William Street, Melbourne, C.1.

