

INNOVA

toyota.com.my

PRESTIGE PERFECTED

Indulge in the luxurious new Captain Seats



TOYOTA

ALL ABOUT THE DRIVE

Actual vehicle may vary from printed image

INNOVA 2.0X

The new Innova 2.0X now comes with new second row captain seats, luxurious black combination leather seats and a stylish crossover design.



Actual vehicle may vary from image shown



2nd-row Captain Seats



Retractable Cup Holders



17" Alloy Rims



LED Ambient Lighting*



8-way Power Adjustable Driver Seat



**Premium Black Combination Leather Seats
(7-seater Arrangement)**



**Automatic LED Projector Headlamps (with
Follow Me Home Function), LED Daytime Running
Lights (DRL) and Front LED Fog Lamps**



**DVD-AVX (Audio Visual Auxiliary)
System with Reverse Camera***



Instrument Panel with Luxurious Wooden Trim*

*2.0X & 2.0G only
Image(s) shown may vary for different variants

INNOVA 2.0G

The Innova can comfortably accommodate your whole family with 8 seats and a spacious interior.



Power Adjustable & Retractable
Wing Mirrors with Turn Signal Lamp
& Puddle Lamp*



Shark Fin Antenna



Easy Closer Back Door*



16" Alloy Rim**

SAFETY



Have greater peace of mind with **BEST-IN-CLASS** safety features in all variants of the Innova.

Image(s) shown may vary for different variants

7 SRS Airbags

Driver, front passenger, side, curtain and driver's knee airbags provide complete protection for driver and passengers in the event of a collision.

ACTIVE SAFETY

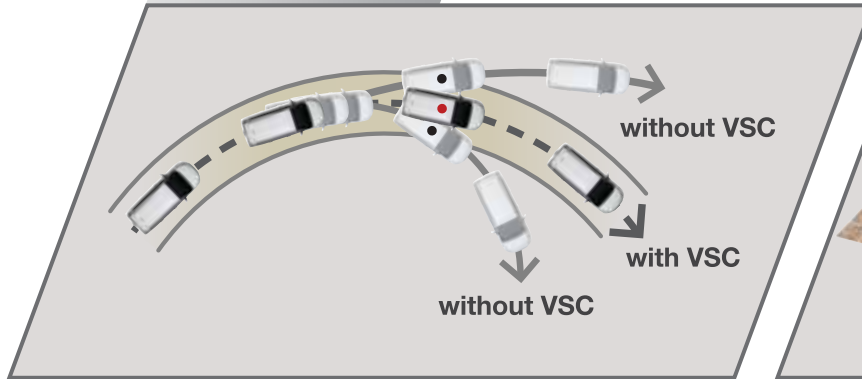

Vehicle Stability Control (VSC)
Intelligently brakes individual wheels to prevent understeer and oversteer.

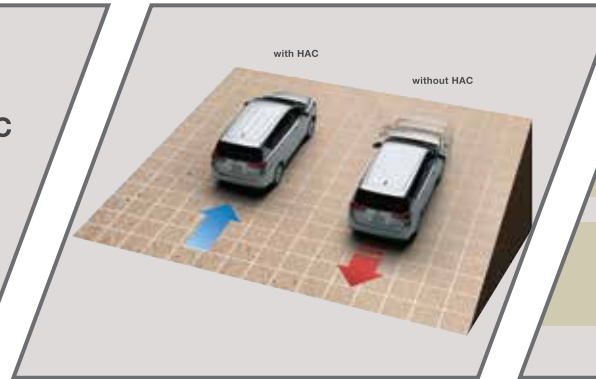

Hill-start Assist Control (HAC)
Prevents the Innova from rolling backwards when moving forward up a steep slope from standstill.

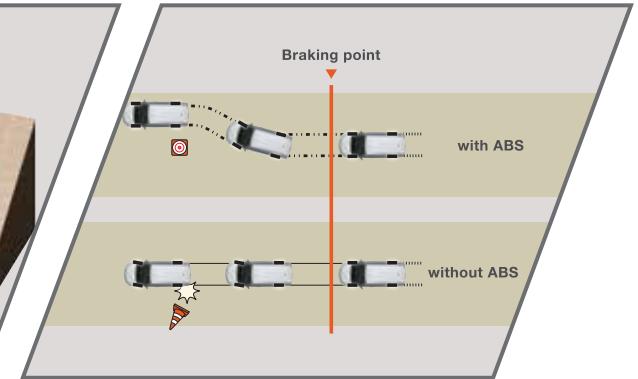

Anti-lock Brake System (ABS) with Electronic Brake-force Distribution (EBD) and Brake Assist (BA)

Prevents tyres from locking during braking, for more stable stops especially on slippery road surfaces. Brake Assist automatically applies a large braking force when sudden braking is detected.

PASSIVE SAFETY

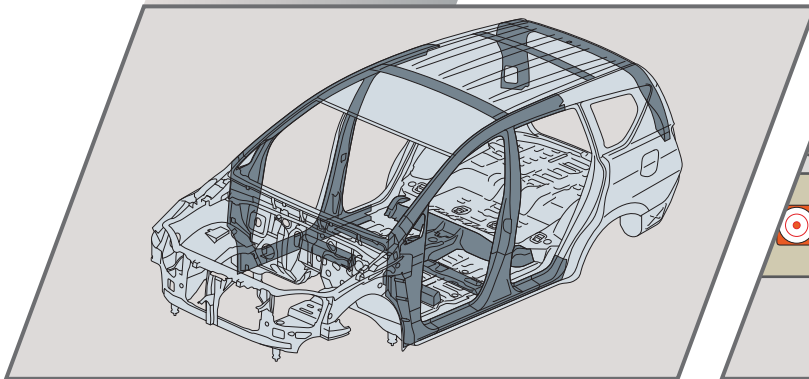

Impact Absorbing Body & Frame Structure
The Innova's body structure is made of high-tensile steel sheets and supplementary materials to absorb impact in the event of a collision.

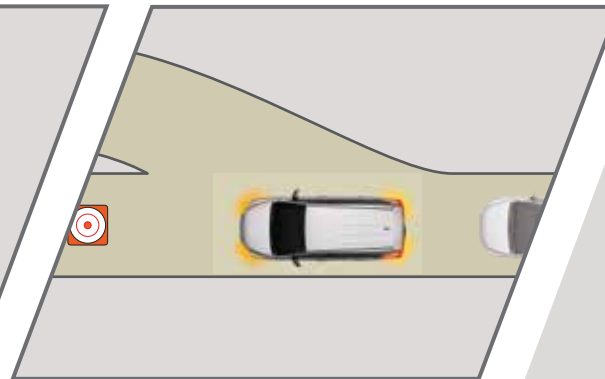

Emergency Stop Signal
Hazard warning lights are activated when sudden braking is detected to warn vehicles behind.



Innova has been awarded a 5-star rating in the Adult Occupant Protection category.



Smart Entry & Start System*



Front & Rear Automatic Air-conditioning*



Optitron Meter with 4.2" Colour Multi-information Display*



Spacious 8-seater**



Multiple Storage Spaces



Auto Up/Down Power Window with Jam Protection for all windows*



Foldable 2nd-row Seat Back Table*



Upper Glovebox with Cooler Function

*2.0X & 2.0G only **2.0G & 2.0E only
Image(s) shown may vary for different variants

PERFORMANCE

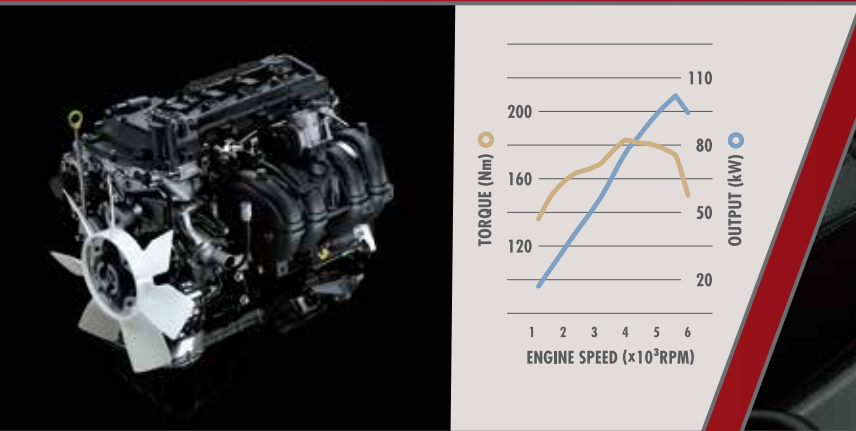

2.0L 1TR-FE Dual VVT-i Engine

The 2.0L VVT-i engine provides enhanced fuel efficiency and midrange torque for more fun wherever you go.



6-speed AT Transmission

Standard in all automatic variants, the wider gear ratio spread provides more power during acceleration, and low cruising RPM for better fuel efficiency and reduced noise.



Drive Mode Switch

Choose from 3 drive modes:

Normal: The best balance between fuel efficiency and performance for everyday use.

ECO: Reduces power consumption and optimizes A/C cooling for maximum efficiency.

Power: Enhances acceleration for a more exciting drive.

INTERIOR



COLOUR SELECTION

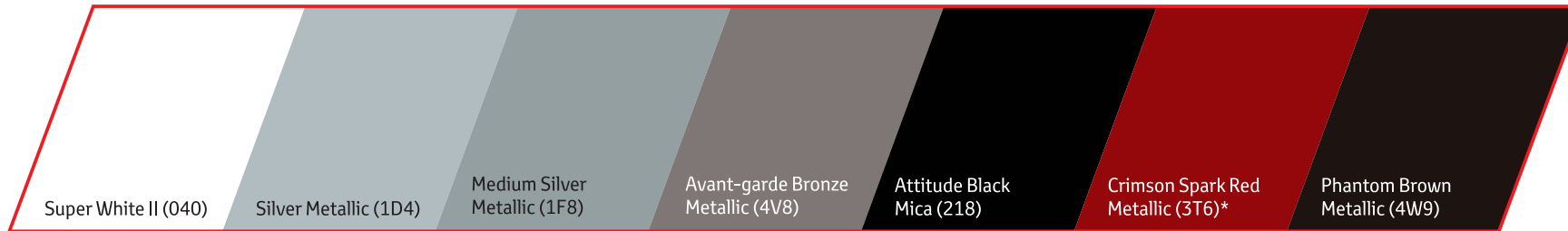

*2.0X only

OPTIONAL ACCESSORIES



Panoramic View Monitor (PVM)

360° view that allows you to be aware of hazards surrounding your vehicle during parking.



Digital Video Recorder (DVR)

Always feel at ease thanks to the Digital Recorder that records every detail of your journey.



DVD-AVN (Audio Visual Navigation) System With Reverse Camera

DVD Player with 8" Capacitive Touch Screen, Smartphone Connectivity**, Wi-Fi, Internet Browser, Voice Recognition, HDMI, USB, Bluetooth®, Navigation & Reverse Camera.

**Functions may vary depending on smartphones



DVD-AVX (Audio Visual Auxiliary) System With Reverse Camera***

DVD Player with 8" Capacitive Touch Screen, Smartphone Connectivity**, Wi-Fi, Internet Browser, Voice Recognition, HDMI, USB, Bluetooth® & Reverse Camera.

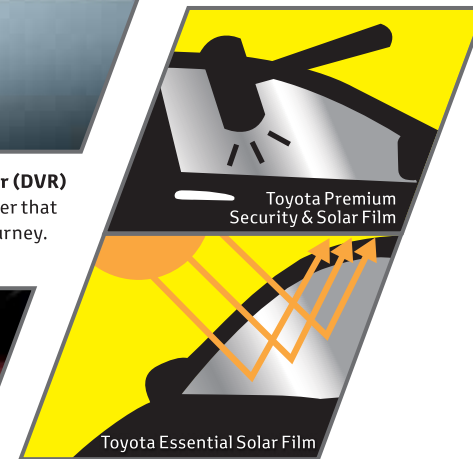

Window Tint

Protect yourself and your passengers from harmful UV and infrared rays, and glare.

***2.0E only

Image(s) shown may vary for different variants

SPECIFICATIONS

VARIANT	2.0X (AT)	2.0G (AT)	2.0E (AT)	
ENGINE				
Model	1TR-FE			
Type	4-cylinder In-line, 16-valve DOHC with Dual VVT-i			
Displacement (Bore x Stroke)	cc (mm)	1,998 (86.0 x 86.0)		
Max. Output (SAE-NET)	kW (PS) / rpm	102 (139) / 5,600		
Max. Torque (SAE-NET)	Nm / rpm	183 / 4,000		
TRANSMISSION				
Type	6-speed Automatic with Sequential Shifter			
CHASSIS				
Tyres & Rims (Including Spare Wheel)	215/55R17, Alloy	205/65R16, Alloy		
MEASUREMENTS				
Weight	Kerb / Gross (kg)	1,740 / 2,320	1,715 / 2,360	
Fuel Capacity	(litre)	55		
EXTERIOR FEATURES				
Enhancement Package	With (Front & Rear Bumper Spoiler, Overfenders & Rocker Lower Moulding)	Without		
Headlamps	Type	Automatic LED Projector (with Follow Me Home Function)	Automatic Halogen Multi-reflector (with Follow Me Home Function)	
	Levelling	Automatic	Manual	
Daytime Running Lights	With (LED)	With (Bulb)		
Fog Lamps	Front / Rear	With (LED) / With	Without / With	
Radiator Grille		Chrome with Black Paint	Chrome with Silver & Black Paint	
Wing Mirrors		Power Adjustable & Retractable with Turn Signal Lamp & Puddle Lamp	Power Adjustable with Turn Signal Lamp	
Door Handles		Chrome	Body Colour	
Rear Spoiler		With (With LED High Mount Stop Lamp)		
Wipers	Front / Rear	Intermittent with Time Adjustable & Mist / With	Intermittent & Mist / With	
INTERIOR FEATURES				
Meter Panel	Type	Optitron with Illumination Control	Back Light	
	Multi-information Display (MID)	With (4.2" Colour TFT)	With	
Instrument Panel		Wood and Silver Trim	Black and Silver Trim	
Audio System	Type	DVD Player with 8" Capacitive Touch Screen, Smartphone Connectivity*, Wi-Fi, Internet Browser, Voice Recognition, HDMI, USB, Bluetooth® & Reverse Camera	CD Player with Tuner, MP3, AUX-Jack, USB & Bluetooth®	
	Speakers	6		
Air-conditioning	Front & Rear	Automatic	Manual	
Steering Wheel	Type	3-spoke Leather Wrapped with Wood & Silver Trim, Tilt & Telescopic Adjustable	3-spoke Urethane with Silver Trim, Tilt & Telescopic Adjustable	
	Switches	Audio, MID, Bluetooth® Hands-free		
Smart Entry & Start System		With	Without (with Jack Knife Key)	
Power Windows		With (Auto Up / Down with Jam Protection for All Windows)	With (Driver Side Auto Up / Down with Jam Protection)	
Sunvisor	Driver & Passenger	With (Mirror & Lamp)	With (Mirror)	
Drive Mode		With (Normal, ECO & Power Mode)		
Gear Knob		Leather Wrapped with Silver Ornament	Urethane	
Accessory Power Outlet		With (12V x 2)		
Assist Grips		Roof x 6		
Door Trim		Fabric Wrapped with Silver, Piano Black & Wood Trim	Fabric Wrapped with Silver & Piano Black Finish	
Seats	Material	Combination Leather (Black)	Fabric (Black)	
	Seating Capacity	7	8	
	Front Seats	Driver Seat	8-way Power Adjustable	6-way Manual Adjustable
		Front Passenger	4-way Manual Adjustable	
	2nd Row	Type	Captain Seats, One Touch Tumble	60:40 Split Fold, One Touch Tumble
		Headrests	2	3
		Armrest	With	With (with Cup Holders)
3rd Row	Type	50:50 Split Fold, One Touch Easy Space Up		
	Headrests	3		

- UMW Toyota Motor reserves the right to alter any details of specifications and equipment without notice.
- Details of specifications and equipment are also subject to change to suit local conditions and requirements.
- Vehicle and specifications in this catalogue may vary from models available locally. Vehicle body and accessory colours might differ slightly from the printed photos in this catalogue.
- Optional accessories are available at extra cost.
- All images are used for illustrative purposes.



5 years warranty from the date of first registration with unlimited mileage. Terms and Conditions apply.



Innova has been awarded a 5-star rating in the Adult Occupant Protection category



For Your Auto-Financing Needs

For more information, please contact:

MO9/Y18

VARIANT	2.0X (AT)	2.0G (AT)	2.0E (AT)	
INTERIOR FEATURES				
Storage	Centre Console Box	With (Soft Lid & Wood Trim)	With (Soft Lid)	
	Rear USB Ports	With		
	Lower Glove Box	With (With Lock & Damper)		
	Upper Glove Box	With (With Cooler Function)		
	Sunglass Holder	With		
	Front Seat Back Pockets	With (With Wood Trim Foldable Seatback Table & Shopping Hook)	With (With Foldable Seatback Table & Shopping Hook)	With (With Shopping Hook)
	Cup Holders	With		
Lamps	Personal Front / Rear	With / With		
	Dome Lamp	With		
	Luggage Room	With		
	Ignition Key / Push Start Button	With		
	Roof Ambient Lighting	With (LED)	Without	
Easy Closer Back Door	With	Without		
SAFETY				
ACTIVE				
Anti-lock Brake System (ABS)	With Electronic Brake-force Distribution (EBD) & Brake Assist (BA)			
Vehicle Stability Control (VSC)	With Traction Control (TRC), Hill-start Assist Control (HAC), Emergency Stop Signal (ESS)			
Parking Sensors	With (Front & Rear)			
PASSIVE				
SRS Airbags	7 (Driver, Front Passenger, Side, Curtain & Driver's Knee)			
Seatbelts	Front	3-point ELR x 2 with Pretensioner & Force Limiter		
	2nd Row	3-point ELR x 2	3-point ELR x 3	
	3rd Row	3-point ELR x 3		
Height Adjustable Seatbelt Anchor	With (Front)			
ISOFIX (Child Restraint System)	With (Outboard 2nd Row Seats)			
SECURITY				
Alarm System	2 Remote Control Keys, Immobiliser, Siren with Backup Battery, Ultrasonic Sensor, Glass Break Sensor, Double Locking & Speed Auto Door Lock			
OPTIONAL				
DVD-AVX System with Reverse Camera	With	DVD Player with 8" Capacitive Touch Screen, Smartphone Connectivity*, Wi-Fi, Internet Browser, Voice Recognition, HDMI, USB, Bluetooth® & Reverse Camera		
DVD-AVN System with Reverse Camera	DVD Player with 8" Capacitive Touch Screen, Smartphone Connectivity*, Wi-Fi, Internet Browser, Voice Recognition, HDMI, USB, Bluetooth®, Navigation & Reverse Camera			
Window Tint	Toyota Premium Security & Solar Film / Toyota Essential Solar Film			
Panoramic View Monitor (PVM)	Optional			
Digital Video Recorder (DVR)	Optional			

*Functions may vary depending on smartphones. For details, please contact your nearest Toyota showroom.

