

# Fargo

**SOLID.. AND BUILT TO LAST**





# Fargo

Fargo trucks are engineered for solidity, staying power and to make driving safe and comfortable . . . that covers practically everything you could wish for in a truck. But Fargo goes a step further than this.

Whether you handle 2½-3 tons, 5 or 6 tons, work way outback or in the city, your Fargo model has the inbuilt strength to match that job . . . match your working conditions . . . and with something in reserve.

Fargo has been engineered by Chrysler Australia . . . specially for Australia . . . engineered with you in mind, and this model Fargo is the best we've ever built.

**Chrysler Australia Limited**

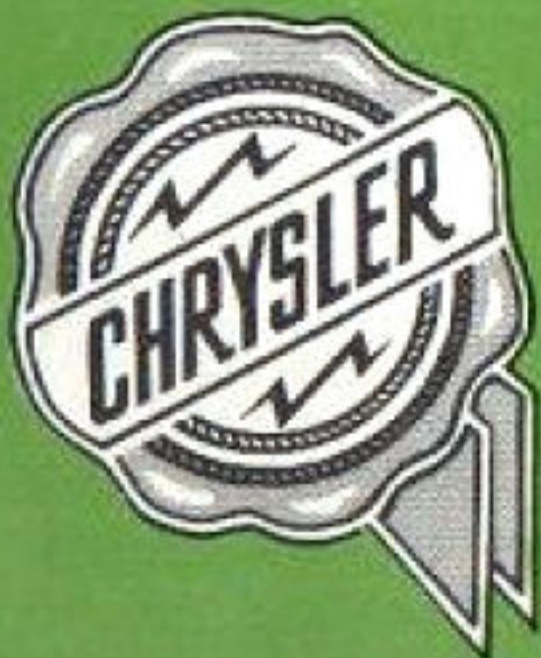

**.. gives  
the power  
you want**

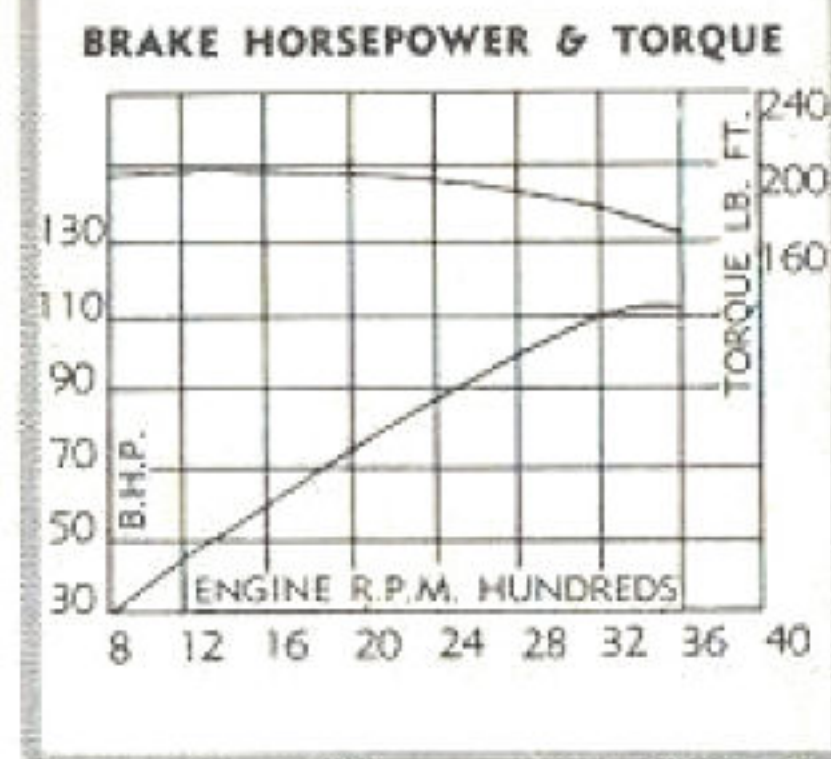

B.H.P. 112 at 3600 r.p.m.,  
torque 198 lbs. ft. at 1400 r.p.m.

This engine has reserve power in all speed ranges, the result of specially shaped combustion chambers. The 6.6 to 1 compression ratio is just right for greatest efficiency, even on normal fuel, and it avoids excessive heat and stresses. Precision engineering everywhere saves repairs, time off the road. Chrome plating of the top ring makes cylinder walls and piston rings last longer. Special heat-resistant alloy steel valves last longer, too - are effectively cooled, have exhaust valve seat inserts. There's full pressure lubrication even at engine speeds of 800 r.p.m.-and the oil circulates free from grit and sediment. Cooling is heavy duty, eliminates hot spots, provides even warm-up. In every way, here is the power - and power unit you want.

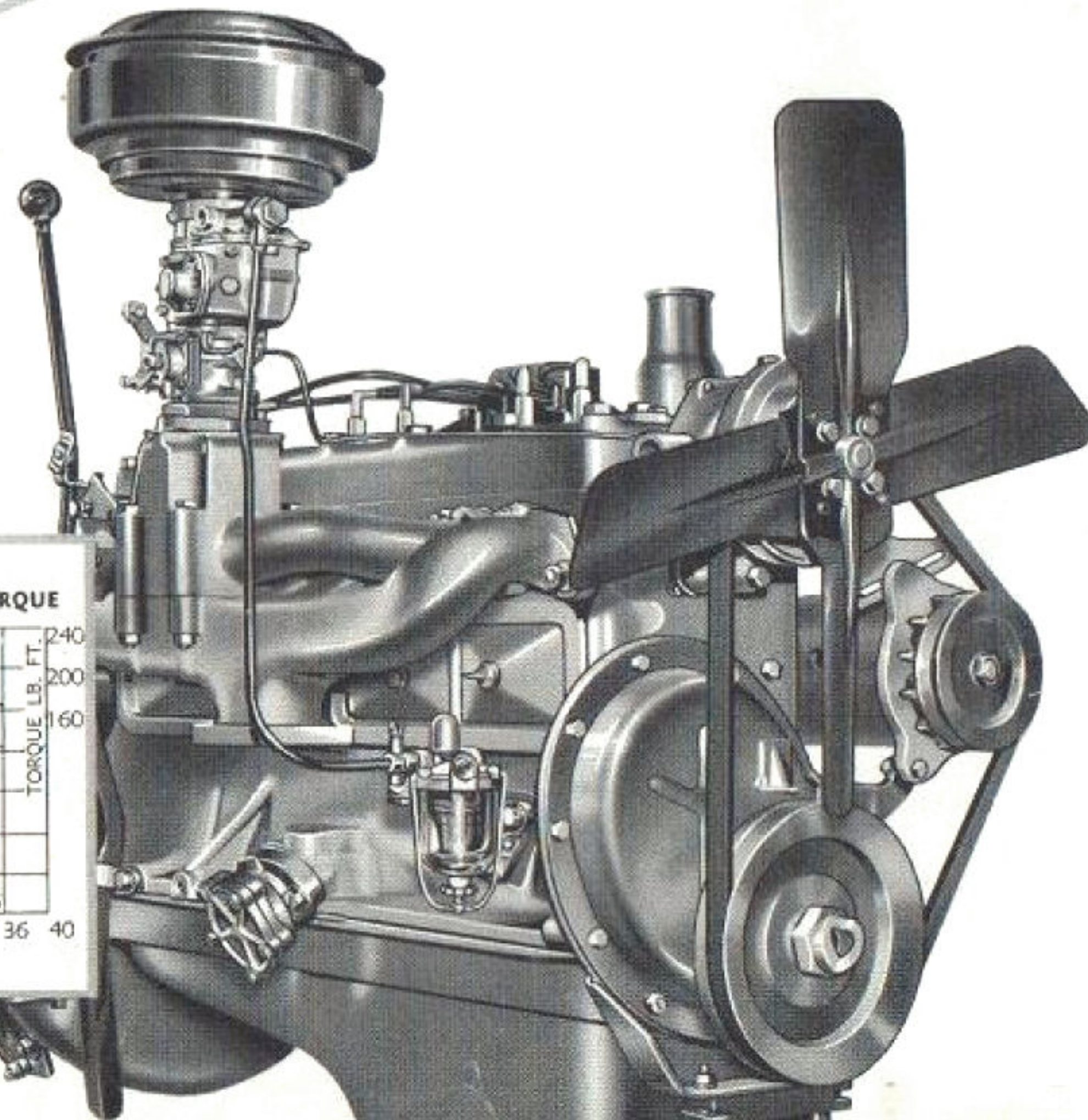





**..has the cab with the comfort and safety you need**

Now you can drive with greater ease, greater peace of mind. Enjoy three-man seating comfort in this roomiest of cabs. Seats are wide and at the right height for maximum comfort and to get full advantage from the all-round expanse of safety glass. There's a big, new, one-piece windshield, a rear window 25½" plus rear quarter windows. It's the safest visibility ever provided in a truck. Safe vision . . . safe, all-steel body construction, too. Box section door posts and other structural units give extra rigidity—brace the whole cab against the thump and bump of rugged work. Yes, this is the cab designed in every detail to give you more of what you need for your job.

The Pilot-house cab lets you see in all directions—and you don't have to twist and turn to see what is coming behind or at the sides. How much safer it is to drive, especially in heavy traffic . . . how much easier it is when backing in and out of narrow spaces. This cab has every feature you need to ease the strain of long hours of driving.

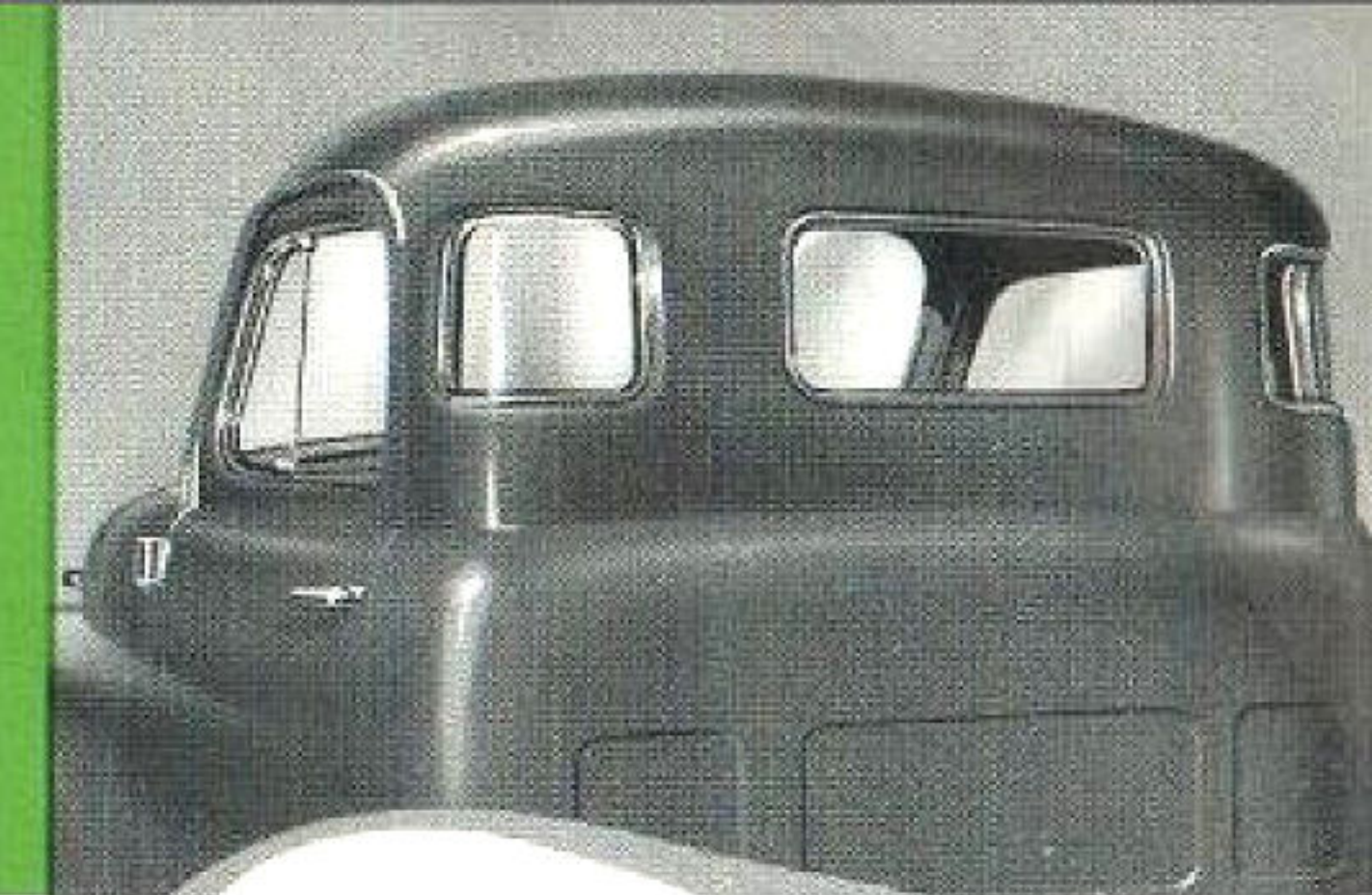

It's good to drive a good looking truck . . . and here's the styling that will add prestige to any business . . . give new pride to every driver. Once again, Chrysler has set the pace in functional design and features . . . But there's a very practical aspect of this smartness, an aspect important to owners who take pride in the continued good appearance of their trucks. With Chrysler Australia producing all its truck sheet metal, any panels damaged beyond repair are readily available.

**..style that adds prestige to your business!**





# Fargo

*2½ - 6 ton trucks*

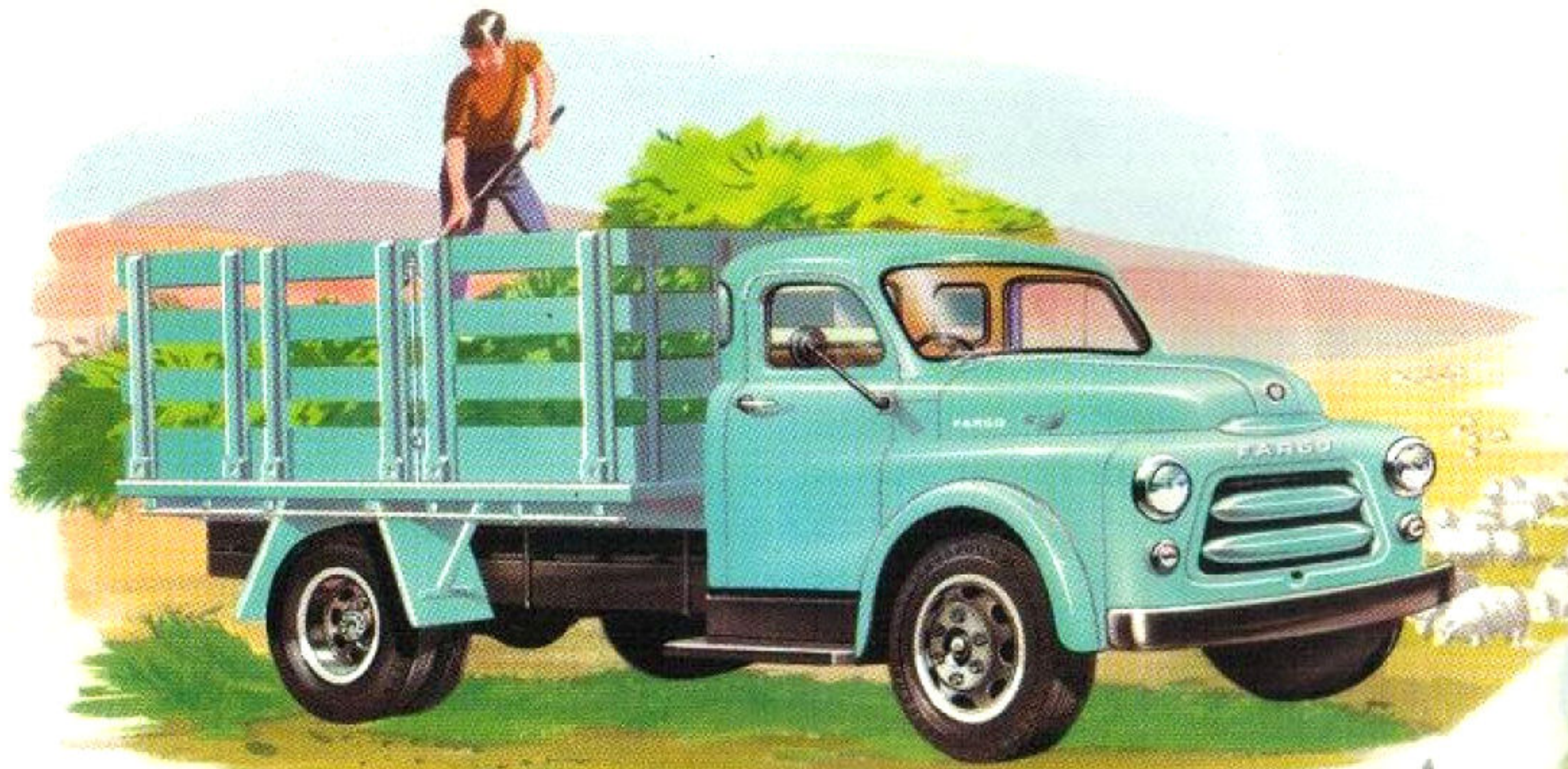

**2½ -- 3 TONS**  
**12,320 lbs. G.V.W.**

**5 TONS**  
**18,500 lbs. G.V.W.**

With the choice of a single speed 6.66 to 1 rear axle or Eaton 2-speed, this model can match practically any job in 5-ton haulage . . . city running or general needs outback - long distance haulage or constant work in hilly country. The long 171¼" wheelbase and cab to axle measurement of 103¼" allows a really generous size tray to be mounted and still maintain correct load distribution.

Here is the truck with every answer to every need in this payload range. The cab to axle dimension of 91" allows a big loading area without dangerous overhang of the body. The 250.6 cub. in. capacity engine with 5.85 to 1 ratio rear axle gives all the pulling power necessary for the load and with maximum economy. The powerful hydraulic braking system, incorporating two leading shoes on front wheels, adds to ease of handling - a particular benefit in city delivery work.





## 6 TONS 21,000 lbs. G.V.W.

Two wheelbases are available in this payload capacity - 165" for tipping bodies and semi-trailer work or the 171½" wheelbase for timber, wheat, wool, cement or general heavy merchandise. Both models have 6.66 to 1 axles, with heavy duty two-speed axles as optional equipment, ratio 6.14 and 8.52 to 1.



## 6 TONS (DIESEL)

Power unit is the Perkins P-6 which is known, proven and accepted by truck owners the world over. Engine develops 77 B.H.P. (nett) at 2,400 r.p.m. and 196 lbs. ft. torque at 1,500 r.p.m. Engine features include dry, replaceable cylinder liners, 5 ring pistons, 7 bearing crankshaft, combination direct and indirect injection for easy starting. Truck wheelbase is 171½" and heavy duty 2-speed axle standard equipment.

Product of



For lighter loads there are 15 cwt. DeLuxe and Standard utilities, Panel Van, Express, Suburban . . . 25 cwt. and 30 cwt. trucks.





Check these chassis dimensions and you'll choose...

# Fargo

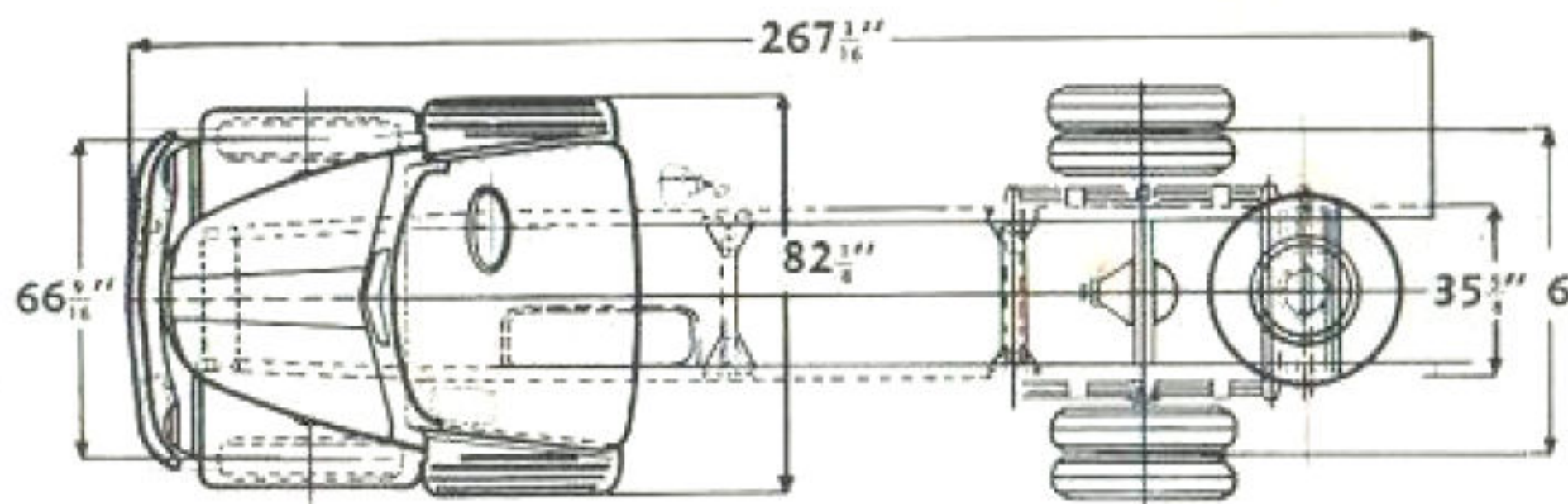
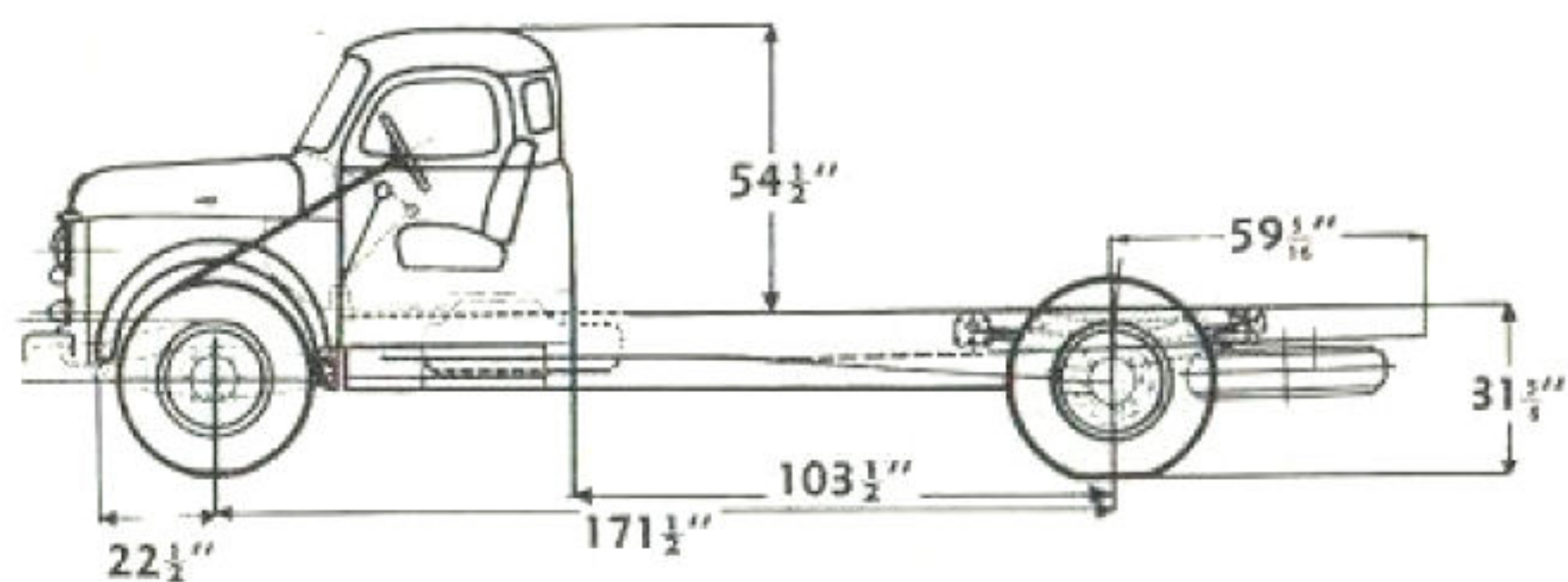

171 1/2  
in.  
W.B.  
CHASSIS

165  
in.  
W.B.  
CHASSIS

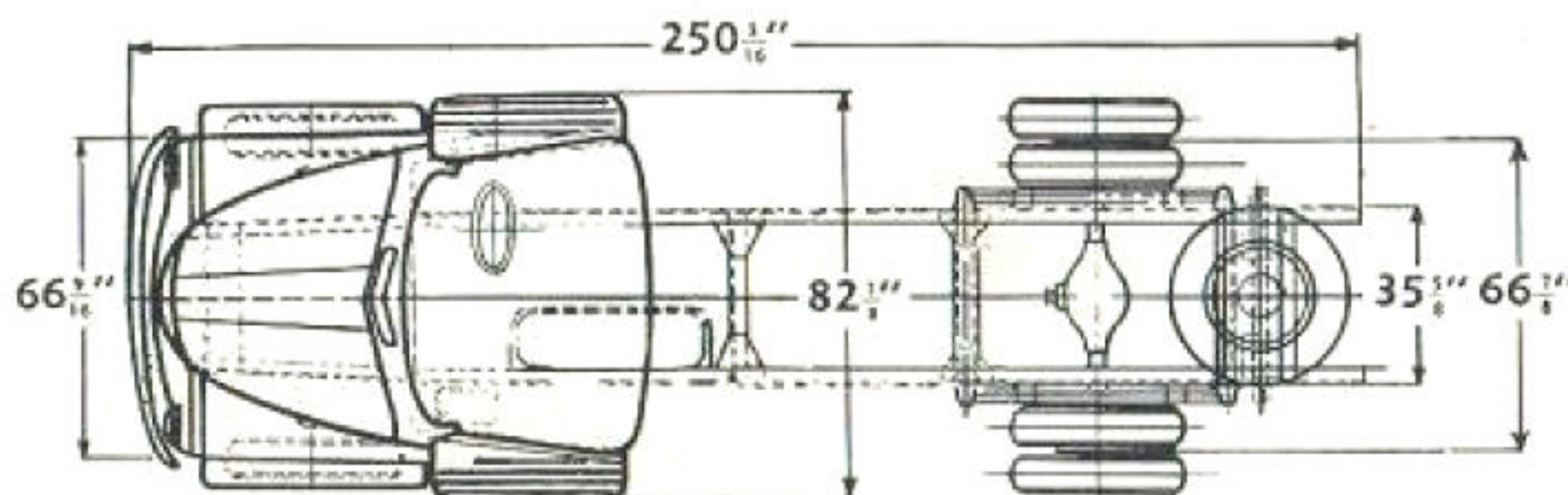
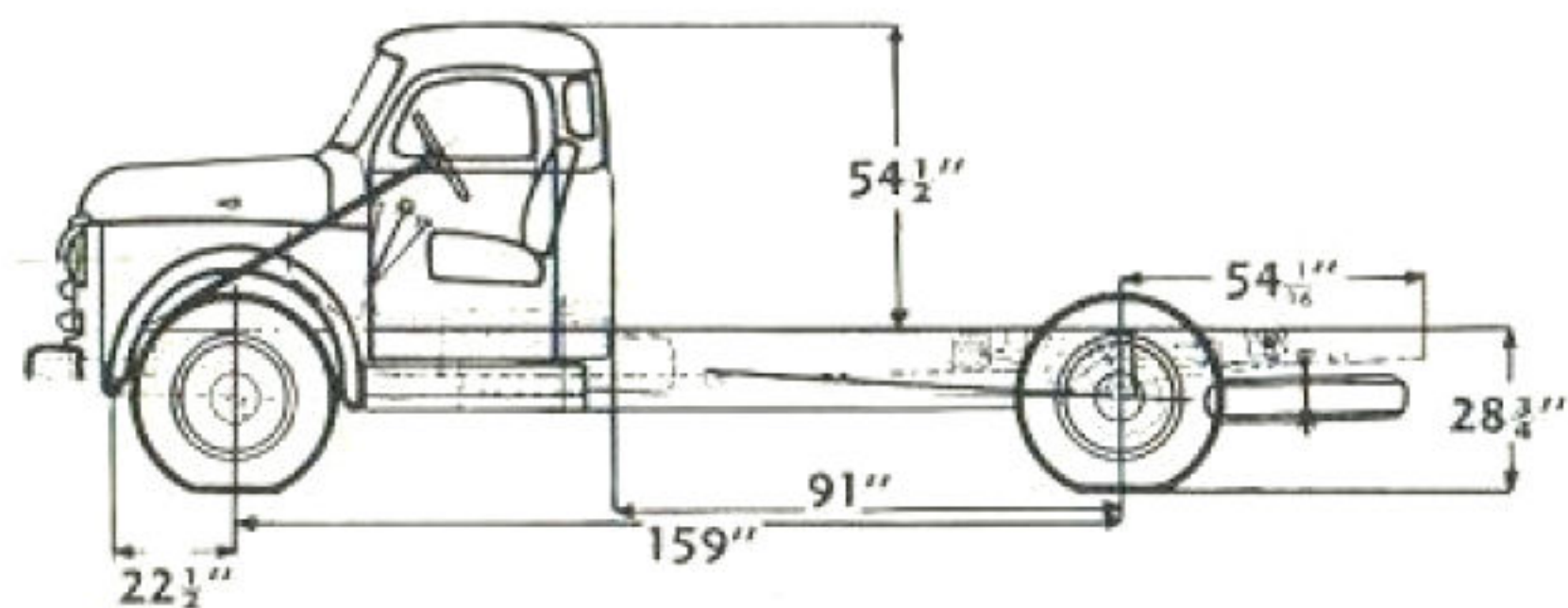
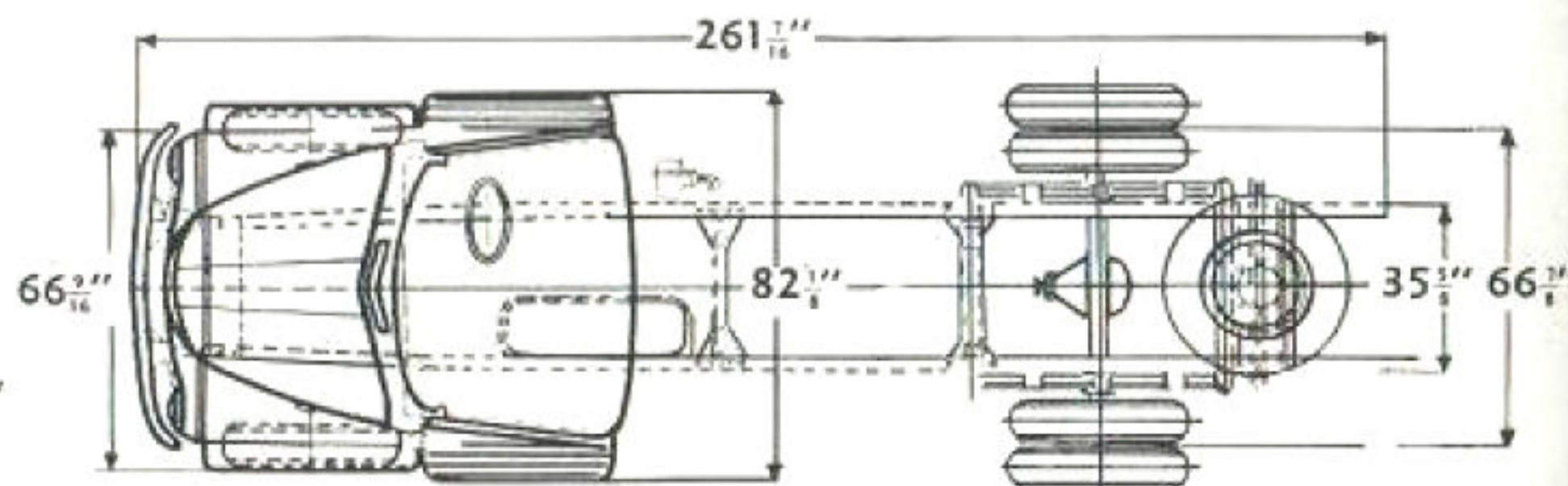
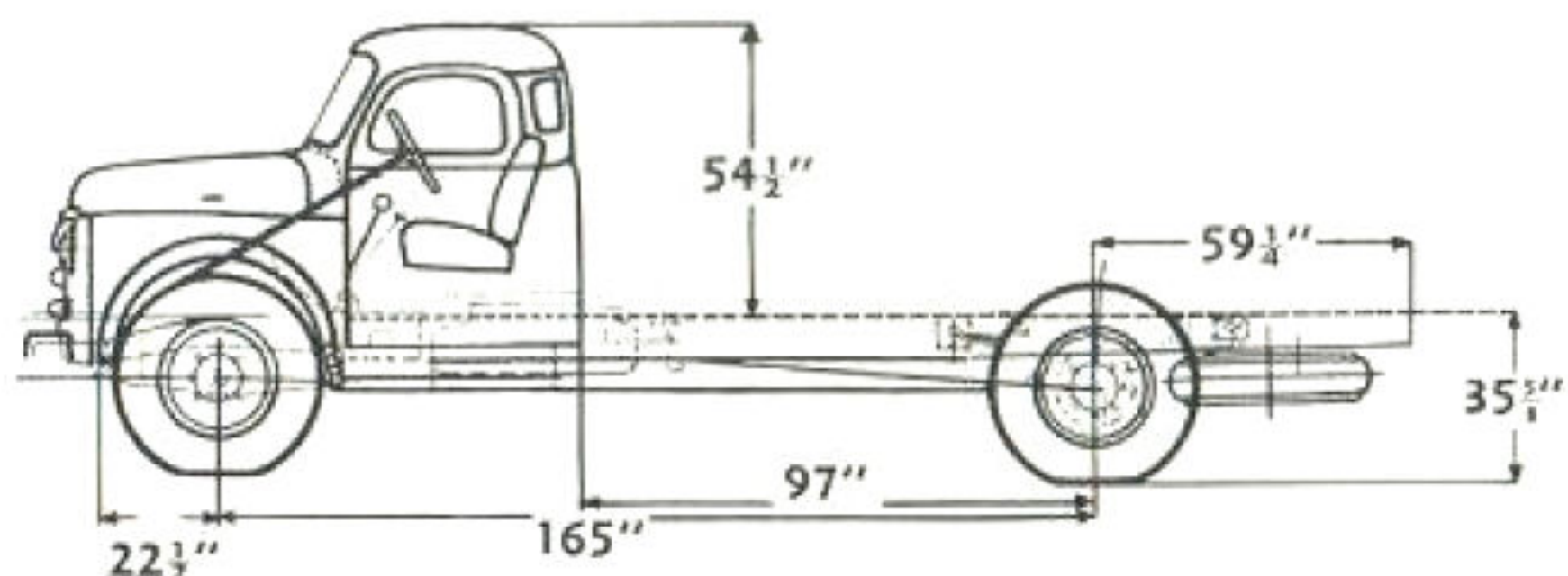

159  
in.  
W.B.  
CHASSIS



**FUEL SYSTEMS—Petrol Engine**—Downdraft Solex carburettor with mechanical fuel pump and oil bath air cleaner. 15 Imp. gall. fuel tank with filtered petrol feed. Electric fuel gauge on instrument panel.

**Diesel Engine**—Pneumatically governed fuel injection pump and two spray atomisers. Two-stage fuel feed filter system. Heavy duty oil bath air cleaner. Fuel tank capacity 15 Imp. galls. Electric fuel gauge on instrument panel.

**COOLING SYSTEMS**—Heavy duty all models. Full length water jackets and direct cooling to exhaust valve seats by distributing tube. Radiator frontal area 462 sq. ins. Capacity 4 galls. (3½ galls. Diesel). 4 blade 19" dia. fan (Diesel 6 blade 18" dia. fan). Centrifugal water pump actuates circulation. V-belt drive. Thermostatically controlled by-pass.

**ELECTRICAL—Petrol Engine**—12 volt, 9 plate, 60 A.H. MoPar Battery. **Diesel**—two 6 volt, 17 plate, 120 A.H. MoPar Batteries in series.

**FRAMES**—Cold squeeze riveted. Pressed steel side members. Heavy channel section front bumper attached directly to ends of side members. All frames engineered for the G.V.W.

**SPRINGS**—Silico manganese steel, semi-elliptic front and rear. All springs engineered for maximum riding comfort consistent with capacity to carry full payloads. Auxiliary springs as standard equipment all models.

**STEERING**—Model 3-59 cam and lever type, ratio 16 to 1. Other models, cam and roller type, ratio 18 to 1. 18" dia. steel reinforced steering wheel.

**TRANSMISSION**—Models 3-59 and 6-71: 1st 6.4 to 1, 2nd 3.09 to 1, 3rd 1.69 to 1, 4th Direct, Reverse, 7.82 to 1. Oil capacity 5 pints. Models 8-65, 8-71, 8-71D: 1st 7.58 to 1, 2nd 4.38 to 1, 3rd 2.40 to 1, 4th 1.48 to 1, 5th Direct, Reverse 7.51 to 1. Oil capacity 9 pts.

#### TYRE EQUIPMENT

Model	Standard	Optional
3-59	6-7.00 x 20 x 8 ply	6-7.00 x 20 x 10 ply. 6-7.50 x 20 x 8 ply.
6-71	6-8.25 x 20 x 10 ply	6-8.25 x 20 x 12 ply.
8-65	6-9.00 x 20 x 10 ply.	6-9.00 x 20 x 12 ply.
8-71		6-8.25 x 20 x 12 ply.
8-71D		

Road lug tyres available for rear wheels, models 6-71, 8-65, 8-71, 8-71D.

#### WHEELS

Model	Size	Studs
3-59	7-20 x 5.00	6
6-71	7-20 x 6.00	8
8-65, 8-71 & 8-71D	7-20 x 6.50	8

#### WHEELBASES

Model 3-59 (2½ to 3 ton)	159"
Model 6-71 (5 ton)	171½"
Model 8-65 (6 ton)	165"
Model 8-71 (6 ton)	171½"
Model 8-71 Diesel (6 ton)	171½"

**EQUIPMENT**—Chassis is equipped with engine hood with ornament and rugged front fenders. Prefocused headlamps, separate parking lights. Short running boards; Vibrator-type electric horn; Foot operated headlamp dipper; Combination tail and stoplight, instrument panel light, electric fuel gauge, speedometer, ammeter, oil pressure gauge, engine heat indicator, ignition switch with lock, choke, throttle control. Heavy front bumper. Licence brackets. Complete tool equipment includes hydraulic jack.

**CAB**—Solidly welded, all-steel, combining driver comfort, strength and safety. "Pilothouse" corner windows and large windshield give maximum all-round vision. Armour-plate safety glass fitted to windshield, doors and rear window. Well sprung, adjustable chair height seat comfortably accommodates three big adults.

All specifications and acceptance of orders subject to change without notice and without responsibility to Chrysler Australia Limited.

For longer engine life and greatest possible fuel economy, engine speeds should not exceed 3000 r.p.m.

#### AXLES (Front)

Model	Type	Capacity
3-59	Reversed Elliot I beam	3750 lbs.
6-71		6000 lbs.
8-65		6000 lbs.
8-71	Elliot I Beam	6000 lbs.
8-71D		6000 lbs.

#### AXLES (Rear)

Model	Capacity	Ratio
3-59 F.F. Spiral Bevel	9,000 lbs.	5.85 to 1
6-71 Single Speed full floating hypoid	16,500 lbs.	6.66 to 1
Optional 2-speed F.F. Spiral Bevel 8-65 and 8-71	15,500 lbs.	5.83 & 8.11 to 1
Single Speed full floating hypoid	16,500 lbs.	6.14 & 8.52 to 1
Optional 2-speed F.F. Spiral Bevel	16,500 lbs. heavy duty	6.14 & 8.52 to 1
8-71D 2-speed F.F. Spiral Bevel	16,500 lbs. heavy duty	6.14 & 8.52 to 1

All 2-speed axles have electric shift mechanism.

**BRAKES**—Foot brake hydraulically actuates two leading shoes on front wheels and two, fully floating, self centring shoes on rear wheels. On models 6-71 and up, brakes vacuum-servo assisted. Fully compensated mechanical handbrake operates on rear wheels (all models).

**CLUTCH**—Borg and Beck single plate, spring loaded, moulded asbestos linings. Release bearing permanently sealed and lubricated. Dimensions: Models 3-59, 6-71, 8-65, 8-71, outside dia. 11", frictional area 123.7 sq. ins. Model 8-71 Diesel, outside dia. 12", frictional area 149 sq. ins.

**DRIVE**—Hotchkiss, through springs to frame. Tubular propeller shaft, cross and trunnion universal joint and centre bearing.

**THE ENGINES—Petrol**—6 cyl. L-head, bore 3-7/16", stroke 4½", displacement 250.60 ins., taxable H.P. 28.35, B.H.P. 112 at 3600 r.p.m., torque 198 lbs. ft. at 1400 r.p.m., compression ratio 6.66 to 1. **Crankshaft**—precision balanced at rest and in motion. Four bearings, 9 counterweights. **Pistons**—tin-plated aluminium alloy, 4 rings, top ring chrome plated. **Valves**—heat resisting alloy steel. Inserts for exhaust valve seats. Exhaust valves with "Stellite" face and hardened stem tips. Effective valve cooling assured through large water passages and water distributing tube. **Main and connecting rod bearings**—steel-backed babbit metal. All bearings can be replaced quickly, simply. **Continuous pressure lubrication** to all vital engine parts. Oil pump delivers full 40 lbs. pressure at 800 r.p.m.; Floating oil intake; Filtered crankcase ventilation; Oil filter has replaceable element; Oil capacity 9 pints including filter.

**Diesel Engine** flexibly mounted six cylinder unit, bore 3½", stroke 5", displacement 288.6 cubic inches. Taxable horsepower 29.4. Compression ratio 16.8 to 1. Max. B.H.P. 79 at 2,400 r.p.m. Max. torque 198 lbs.-ft. at 1,500 r.p.m. Cylinder block and crankcase cast in one piece in nickel chrome iron. Replaceable dry cylinder liners. Four-bearing camshaft carried high up in offside of cylinder block. Aluminium alloy pistons with five rings each. Fully balanced seven-bearing crankshaft machined from a nickel chrome molybdenum steel forging. Steel-backed copper lead main and big end bearings. Triple roller timing-chain incorporating automatic damping and tensioning device. Pressure lubrication to all bearings and valve gear. Kigass primer and induction heater.

Make a  
detail check  
of these  
features





# Fargo

**Built For The  
Australian Job  
For Lasting Value**

FULL FLOATING SPIRAL BEVEL 2  
SPEED AXLE OPTIONAL ON 6-71 AND  
8-71 PETROL MODELS AND STAND-  
DARD ON DIESEL MODELS

HEAVY DUTY COOLING SYSTEM WITH FULL  
LENGTH WATER JACKETS, THERMOSTATIC-  
ALLY CONTROLLED BYPASS AND AUTOMATIC  
WARM-UP VALVE PROTECTS ENGINE, REDUCES  
WEAR

LARGE CAPACITY OIL-BATH AIR  
CLEANER FILTERS DUST AND DIRT  
FROM INTAKE AIR, PROLONGS ENGINE  
LIFE.

15 GALL. CAPACITY FUEL TANK POSI-  
TIONED WITHIN CHASSIS FRAME FOR  
GREATER PROTECTION AND EFFICI-  
ENT FUME DISPERSAL.

112 H.P. ENGINE DEVELOPS MAX.  
TORQUE OF 198 LBS. FT. AT 1400 R.P.M.

RUGGED, HEAVY-DUTY FRAMES  
CHANNEL SECTION REINFORCEMENT  
8-1/16" X 2-25/32 X 3/16" ON 5 AND 6  
TON MODELS PROVIDES GREATER  
STRENGTH

TWO LEADING SHOES FOR INCREASED  
BRAKING POWER AND STRAIGHT LINE  
STOPS.

SPRINGS ARE ENGINEERED FOR MAXI-  
MUM STABILITY AND RIDING COMFORT  
—HEAVY DUTY AUXILIARY SPRINGS  
STANDARD ON ALL MODELS.

VACUUM POWER ASSISTANCE FOR THE  
HYDRAULIC BRAKES ON 5 AND 6 TON  
MODELS—REDUCES DRIVER FATIGUE  
AND PROMOTES GREATER SAFETY.

TUBULAR PROPELLER SHAFT WITH  
CROSS AND TRUNNION UNIVERSAL  
JOINT AND CENTRE BEARING.

WIDE BASE RIMS ENSURE LONGER  
TYRE LIFE AND GREATER STABILITY  
TO VEHICLE WHEN CORNERING.



The only replacement parts re-  
commended and guaranteed by  
Chrysler Australia for Fargo.

Product of  
**CHRYSLER AUSTRALIA LIMITED**  
ADELAIDE, S.A.