



# 2022 RAM PROMASTER CITY



# PEOPLE AND CARGO MOVER

**CARGO HAULER MEETS PEOPLE CARRIER.** Every day, business owners strive to lower costs, increase efficiencies and make sure they're using the best tools for the job. With commercial-grade capabilities, a robust powertrain, must-have technology and multiple business-friendly features, Ram ProMaster City® hits every target. Available in Cargo Van and Wagon, each one offers customizable interiors perfectly suited for businesses, organizations, shuttles, families and weekend warriors. Spec out your own ProMaster City at [ram.com/promastercity](https://ram.com/promastercity)



WAGON

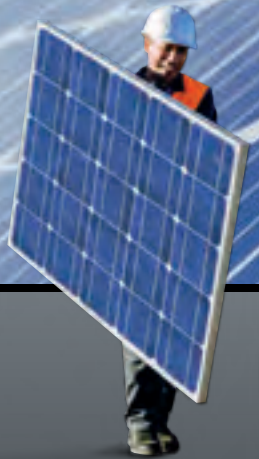

CARGO VAN



# CONTENT LEGEND

HIGHLIGHTS/CLAIMS .....	4-5	60/40-SPLIT REAR DOORS .....	23
PERFORMANCE .....	6	INTERIOR CAPABILITY .....	24
POWERTRAIN .....	7	UCONNECT®/RADIOS .....	25
CAPABILITY .....	8-9	WAGON .....	26-27
PAYLOAD .....	10	INTERIOR .....	28
TIE-DOWNS .....	11	DRIVEABILITY .....	29
INTERIOR VERSATILITY .....	12-13	BUYER'S GUIDE .....	30
CONFIGURATIONS .....	14	DOOR/WINDOW CONFIGURATIONS .....	31
MOPAR® ACCESSORIES .....	15	COLORS, WHEELS AND FABRIC .....	32
ROOF CAPABILITY .....	16-17	SPECIFICATIONS .....	33
MECHANICAL HIGHLIGHTS .....	18-19	BUSINESS SUPPORT .....	34
SAFETY .....	20-22	RAM MERCHANDISE .....	35
		DISCLOSURES/RAM SOCIAL .....	36
			37





# EFFICIENCY THAT WORKS FOR YOU

AMERICA'S  
MOST EFFICIENT  
WORK VAN<sup>1\*</sup>

**BEST-IN-CLASS**

**178 HP & 174 LB-FT OF TORQUE<sup>2</sup>**

2.4L TIGERSHARK<sup>®</sup> MULTIAIR<sup>®</sup>2 I-4

CARGO VAN

**BEST-IN-CLASS**

**28 MPG HWY FUEL ECONOMY<sup>3</sup>**

2.4L TIGERSHARK MULTIAIR2 I-4

**CLASS-EXCLUSIVE**

**9-SPEED  
AUTOMATIC  
TRANSMISSION<sup>2</sup>**

CARGO VAN **UNSURPASSED**

**2,000-LB**

MAXIMUM TOWING<sup>4</sup>

**CLASS-EXCLUSIVE**

**BI-LINK REAR  
SUSPENSION<sup>2</sup>**

OUTSTANDING COMFORT  
& STABILITY

ENGINE OIL CHANGE INTERVALS  
UP TO **10,000 MILES**

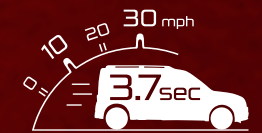

**0-30 MPH IN 3.7 SEC<sup>5</sup>**



\*All disclosures can be found on the last page.





CARGO VAN  
**BEST-IN-CLASS**

**131.7-CU-FT**  
CARGO CAPACITY<sup>6</sup>

CARGO VAN  
**BEST-IN-CLASS**

**1,890-LB**  
MAXIMUM PAYLOAD<sup>2</sup>

ACCOMMODATING  
**OVER 4 FT**  
BETWEEN THE WHEEL WELLS

**STANDARD**  
UCONNECT<sup>®</sup> 3 WITH  
**5-INCH**  
TOUCHSCREEN DISPLAY

CONVENIENT  
**60/40-SPLIT REAR DOORS**  
DOORS OPEN 180 DEGREES  
Designed to accept a standard pallet

**OUR NUMBERS SPEAK VOLUMES**



CARGO VAN  
**BEST-IN-CLASS**  
**28 MPG**  
HWY FUEL ECONOMY<sup>3</sup>



## THE BOTTOM LINE: EFFICIENCY

**LEAN PERFORMANCE BOOSTS THE BOTTOM LINE.** Miles count. Efficiency matters. When you pilot a Ram ProMaster City<sup>®</sup>, you can count on **best-in-class 28 mpg highway fuel economy<sup>3</sup>**. But make no mistake, the robust performance the Ram Brand is known for hasn't been sacrificed. You still get **best-in-class horsepower and torque<sup>2</sup>**, as well as a **best-in-class payload<sup>2</sup>**. That's what's known as Ram tough.

**AERODYNAMIC EXTERIOR.** Thoroughly wind tunnel-tested, Ram ProMaster City delivers a super-low drag coefficient (CD)—it's a mere 0.30. While this helps enable a remarkably quiet interior, reducing wind resistance also acts as a major contributor to impressive efficiency.





# ONE-TWO POWER PUNCH

## 2.4L TIGERSHARK® MULTIAIR® 2 I-4

**BEST-IN-CLASS 178 HORSEPOWER<sup>2</sup>** @ 6,400 RPM

**BEST-IN-CLASS 174 LB-FT OF TORQUE<sup>2</sup>** @ 3,800 RPM

- 3.7 seconds from a full stop to 30 mph<sup>5</sup>
- Smart pulse-width modulation technology on the alternator and fuel pump helps contribute to operating efficiency
- Individual-piston oil squirters help keep internal temperatures in the ideal range
- Position of the exhaust manifold helps minimize noise in the engine compartment
- Runs on 87-octane gasoline
- 5-Year/60,000-Mile Powertrain Limited Warranty<sup>7</sup>

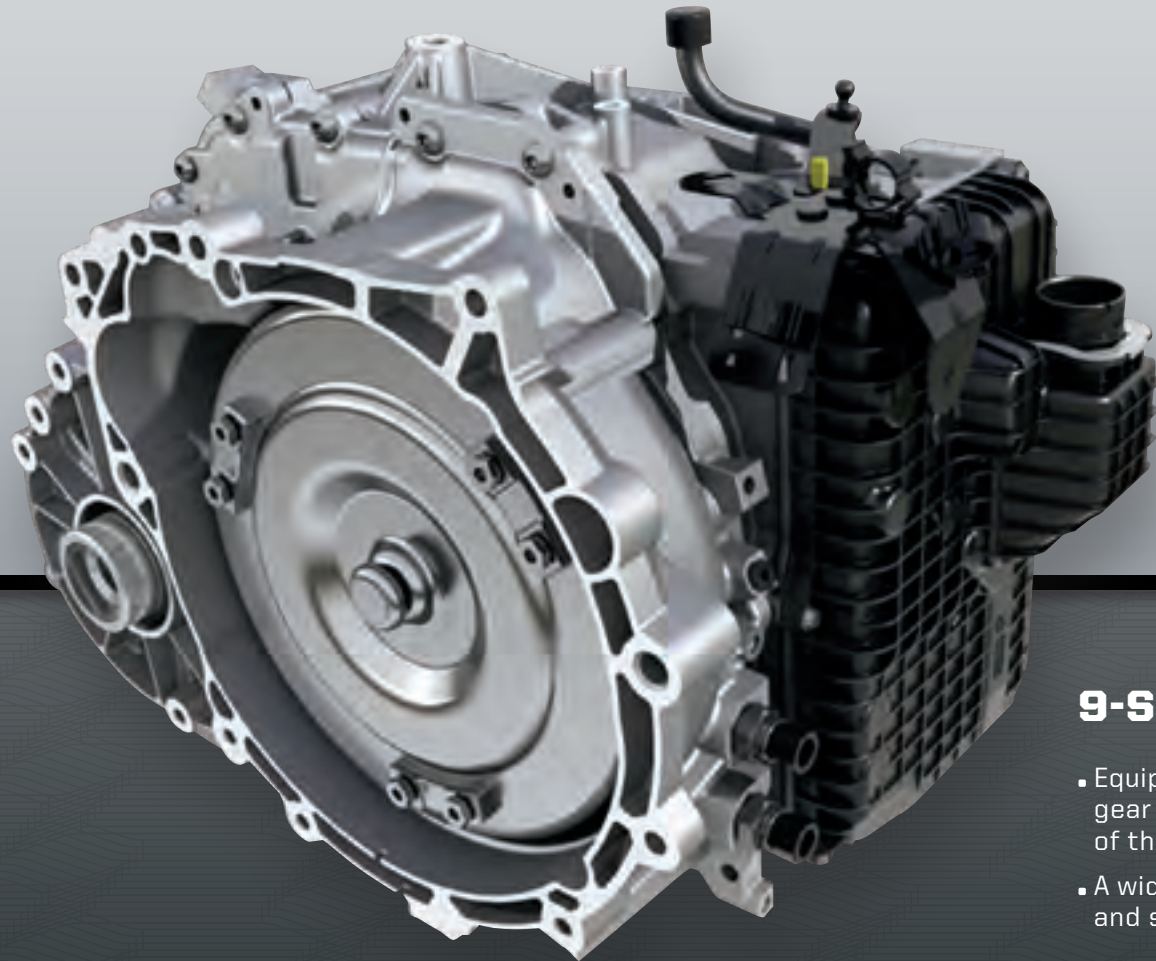

<b>HORSEPOWER</b>	<b>BEST-IN-CLASS 178 HP<sup>2</sup></b> @ 6,400 rpm
<b>TORQUE</b>	<b>BEST-IN-CLASS 174 LB-FT<sup>2</sup></b> @ 3,800 rpm
<b>CONFIGURATION</b>	In-line 4-cylinder
<b>DISPLACEMENT</b>	144 cu in (2,360 cc)
<b>BORE x STROKE</b>	3.46 x 3.82 in (88 x 97 mm)
<b>BLOCK MATERIAL</b>	Aluminum
<b>CYLINDER HEAD MATERIAL</b>	Aluminum
<b>AIR INDUCTION</b>	Naturally aspirated
<b>VALVE TRAIN</b>	Chain-driven DOHC, 16-valve
<b>FUEL DELIVERY</b>	Sequential, multiport injection
<b>RECOMMENDED FUEL</b>	Unleaded regular (87-octane)
<b>COMPRESSION RATIO</b>	10.0:1
<b>ALTERNATOR</b>	160-amp
<b>OIL CAPACITY</b>	5.5 quarts

## 9-SPEED AUTOMATIC TRANSMISSION.

- Equipped with Electronic Range Select (ERS)—an electromechanical gear selection system that provides you with manual shift control of the transmission
- A wide 9.79 ratio spread brings outstanding launch characteristics and smooth, nearly indiscipherable transfer between gears
- Shorter mid-range gears ensure quick transitions, and higher gears—7th, 8th and 9th transitions—relate to lower engine speeds
- High efficiency in all gears and speeds, thanks to nested carriers, dog clutches and advanced hydraulic control unit architecture





**DESIGNED TO DELIVER**

**BEST-IN-CLASS**  
**131.7-CU-FT**  
**CARGO CAPACITY<sup>6</sup>**



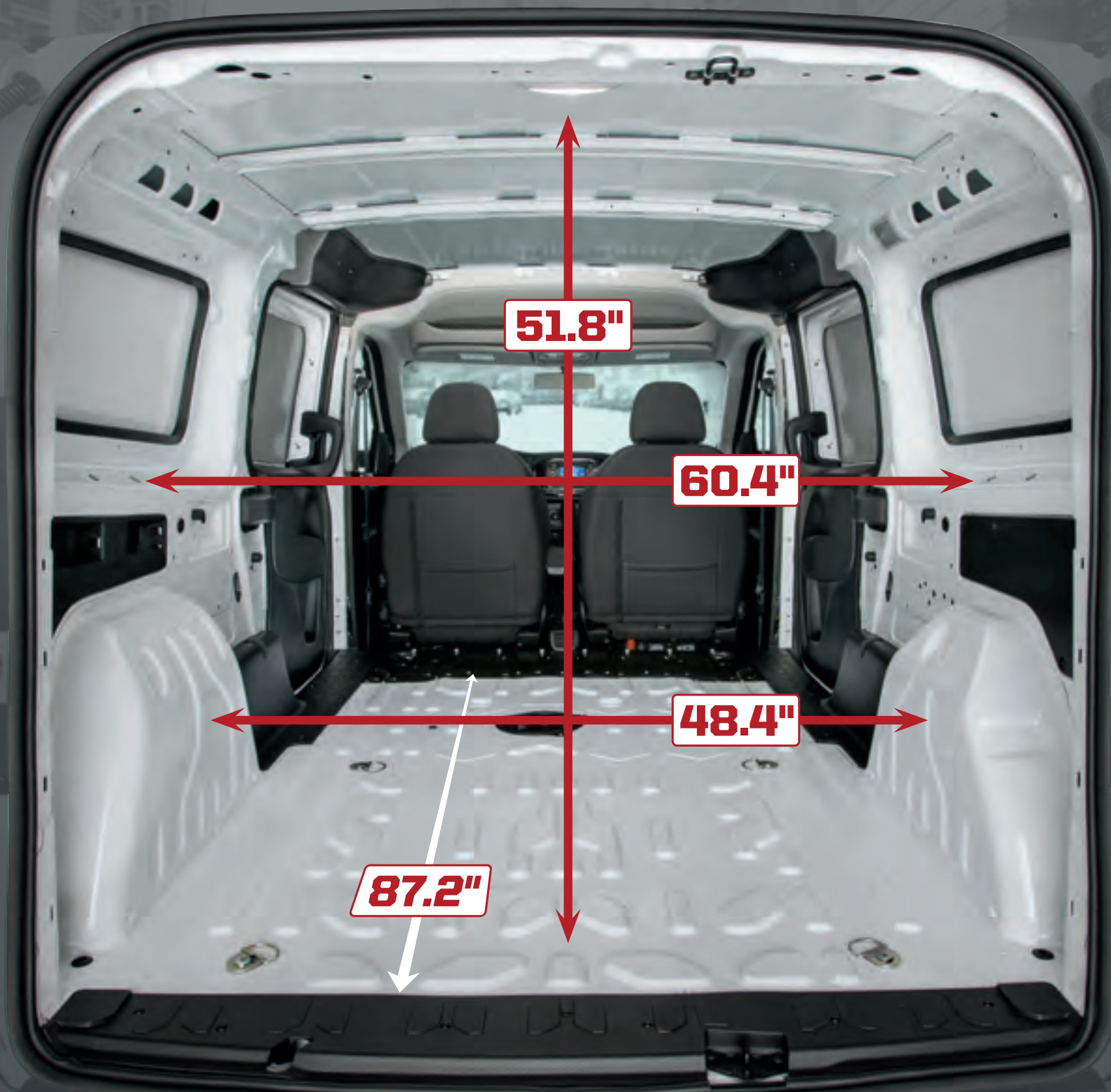

**WORK WITH THE RIGHT EQUATIONS.** Ram ProMaster City® Cargo Van boasts more than 4 feet between the rear wheel wells, allowing building materials, pallets and bulky supplies to be loaded easily. The nearly vertical side-panel construction offers a width of more than 5 feet. Combine that with an interior roof height greater than 4 feet and the result is best-in-class cargo capacity of 131.7 cu ft.<sup>6</sup>

# DIMENSIONS OF CONVENIENCE



# BEST-IN-CLASS MAX PAYLOAD: 1,890 LB<sup>2</sup>



<b>PAYLOAD/TOWING</b>	<b>WAGON</b>	<b>TRADESMAN<sup>®</sup> CARGO VAN</b>
<b>GVWR<sup>8</sup></b>	5,395	5,395
<b>GCWR<sup>8</sup></b>	5,900	5,900
<b>CURB WEIGHT</b>	3,683	3,500
<b>MAXIMUM PAYLOAD<sup>9</sup></b>	1,710	1,890
<b>MAXIMUM TOWING<sup>9</sup></b>	1,870	2,000

Notes regarding this chart: weights given in lb. Trailer Weight Rating and Tow Vehicle Trailing Weight are calculated as specified in SAE J2807. Driver and passenger weight = 300 lb. Trailer Equipment Weight = 50.7 lb for conventional hitch. Specifications subject to change. See dealer for details.





**6 IN-FLOOR TIE-DOWN RINGS**  
(STANDARD ON CARGO VAN)

**4 IN-FLOOR  
TIE-DOWN RINGS**  
(STANDARD ON WAGON)





Shown with aftermarket upfit.

**READY FOR NEARLY EVERY POSSIBILITY**





# INTERIORS THAT WORK FOR YOU

**IT'S MADE TO BE WHATEVER YOU MAKE OF IT.** From the first sketch on the design board, the focus was threefold: make it big, make it user-friendly, make it versatile. This is why you'll find a huge interior made for customized upfits, an easy-to-load floor height, and near-vertical side walls that are upfitter-friendly and make installing specialized commercial shelves or storage racks a breeze. When you're in and out of your van all day long, you'll appreciate a low lift-in height of 23.3 inches at the rear and a step-in height of 21.5 inches at the side. Enjoy easy loading and unloading at the sides with dual sliding doors that open up to an ample 25.8 inches wide and a flat load floor.

Shown with aftermarket upfits.







**OPEN TO CABIN**  
Standard on Tradesman® Cargo Van



**PARTITION WITH WINDOW**  
Available for Tradesman Cargo Van

## CONFIGURE FOR THE TASK AT HAND

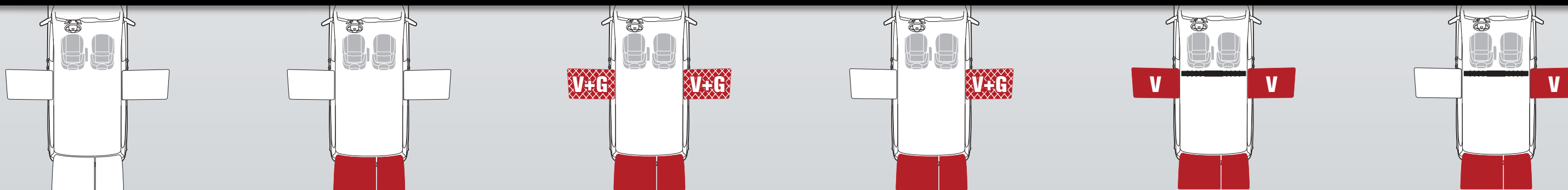

### RAM PROMASTER CITY® CARGO VAN DOOR/WINDOW CONFIGURATIONS

All Ram ProMaster City Cargo Vans can be outfitted with or without a partition. However, due to Federal Safety Regulations (FMVSS), Ram ProMaster City Cargo Vans equipped with side windows without grates require the inclusion of a partition. Above, you will find all available window configurations for 2022MY.

#### LEGEND



SOLID PANEL



FIXED GLASS



VENTED WINDOW



VENTED WINDOW WITH GRATE



PARTITION

Go to **PAGE 32** for complete door/window combination information.



# RAM PROMASTER CITY<sup>®</sup> AUTHENTIC ACCESSORIES

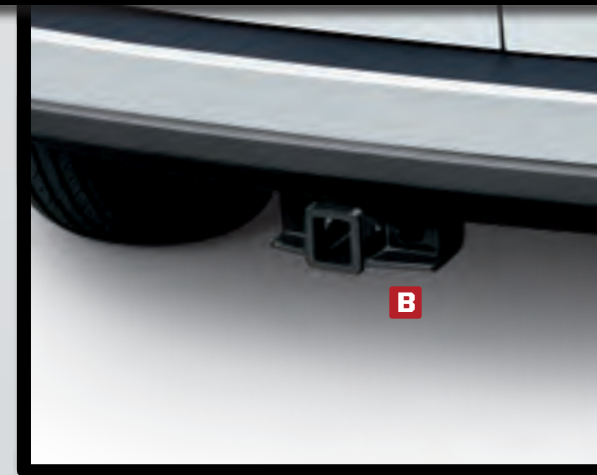

- A.** LED Cargo-Area Lights
- B.** Hitch Receiver<sup>10</sup>
- C.** Molded Splash Guards
- D.** All-Weather Floor Mats, Second Row
- E.** All-Weather Floor Mats, First Row



**WHEN IT COMES TO RAM PROMASTER CITY,** not all parts and accessories are created equal. As the official service, parts and customer care provider for the Ram Brand, only Mopar<sup>®</sup> Parts and Accessories can ensure the proper fit, finish and functionality. That's because they're original equipment, engineered by the same people who designed your vehicle, which means you can personalize your ride with complete confidence.

Mopar is also more than parts and accessories. We're here to help you properly maintain and care for your vehicle. Our certified technicians are trained to know your vehicle best, and our Mopar Express Lane service departments are set up to get you in, out and back on the road. From parts and accessories to expert service and more, always be sure to choose Mopar. Learn more at [mopar.com](https://www.mopar.com)



# 150-LB

ROOF WEIGHT CAPACITY<sup>9</sup>



Shown with aftermarket upfit.

## TOP-LEVEL CARGO MANAGEMENT.

Every Ram ProMaster City<sup>®</sup> has a max roof weight rating of 150 lb<sup>9</sup> that accommodates a variety of available aftermarket equipment to help make sure you can get where you're going with everything you need loaded. The six ready-to-use anchor points make it easy.



**ROOF CAPACITY THAT UPS YOUR GAME**



A top-down view of a white cargo van roof. Six red arrows point to specific anchor points: three on the top edge and three on the bottom edge. The roof has a horizontal ribbed texture. A black handle is visible on the right side.

## **6 READY-TO-USE ROOF ANCHOR POINTS**

(STANDARD ON CARGO VAN AND WAGON. MAX 150-LB<sup>9</sup> ROOF WEIGHT CAPACITY)



# MECHANICAL STRENGTH AND CAPABILITY

## **CARRY BIG PAYLOAD WITH BEST-IN-CLASS GROSS VEHICLE WEIGHT RATING (GVWR) OF 5,395 LB<sup>2,8</sup>:**

To support that big payload, you need a solid foundation. Our chassis is fortified by large-diameter, twin-tube hydraulic MacPherson struts (52 mm) and unibody frame construction. We also added GVWR-tuned, high-performance, stamped-steel, clamshell-sectioned control arms, steel crossmembers, specifically tuned springs, a solid 26-mm-diameter stabilizer bar with cast iron knuckles and large coil springs. Optimized performance gives you real-world capability, nimble maneuverability and a comfortable ride.

**FRAME STRENGTH:** The Ram ProMaster City<sup>®</sup> foundation is a steel unibody design. This architecture helps minimize curb weight and contributes to this vehicle's best-in-class payload up to 1,890 lb<sup>2</sup>; unsurpassed towing up to 2,000 lb<sup>2</sup>; best-in-class GVWR of 5,395 lb<sup>2,8</sup> and an impressive Gross Combined Weight Rating (GCWR) of 5,900 lb<sup>9</sup>.

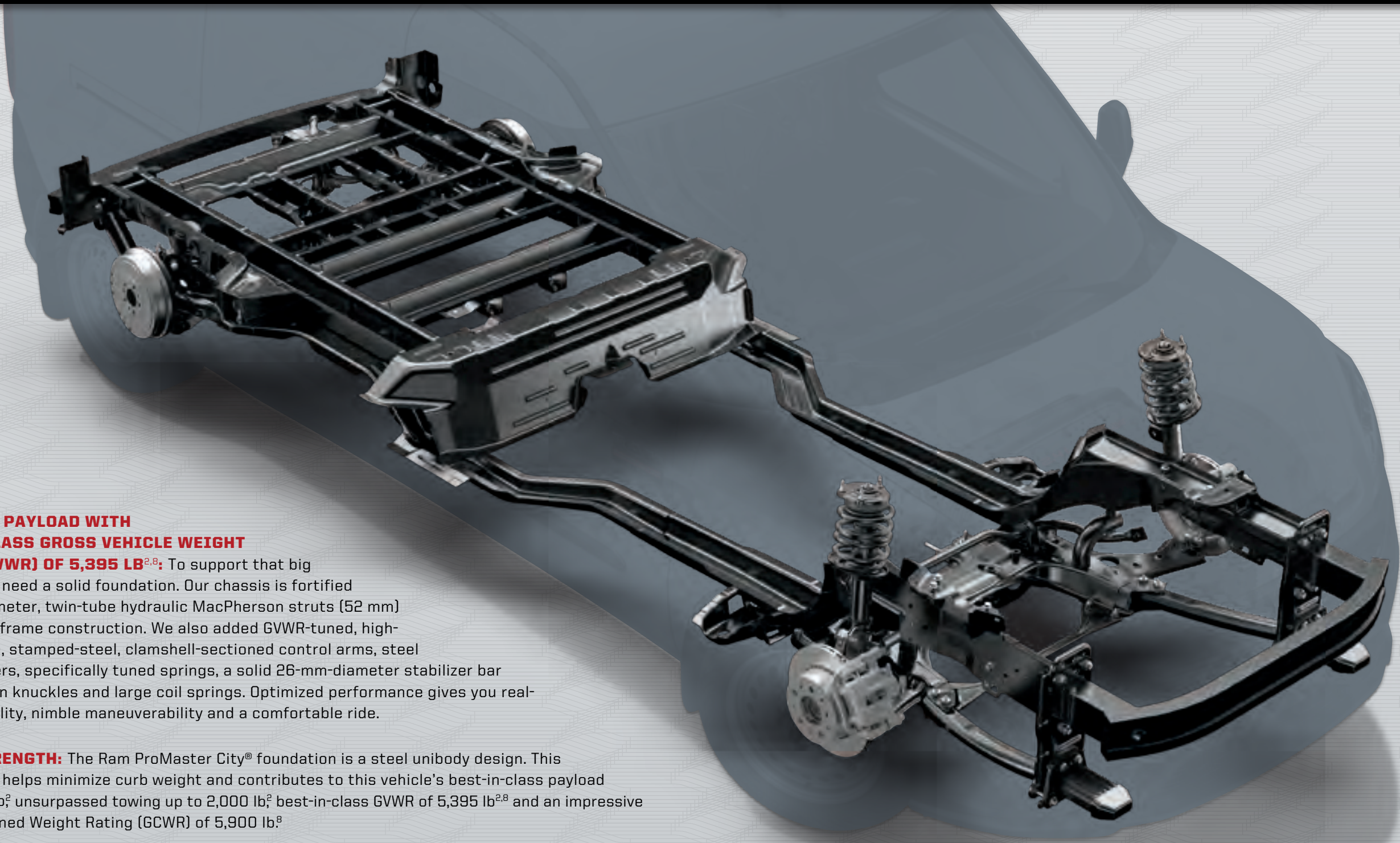





**RACK AND PINION STEERING AND FRONT-WHEEL DRIVE (FWD).**

We teamed rack and pinion steering with FWD to give you multiple advantages: a low flat-floor cargo area, low step-in height and a turning diameter of only 42 feet. Our hydraulic-assist system features a premium steering gear tuned for commercial-level demands. The standard adjustable tilt/telescoping steering column is a welcome convenience in the commercial class.

Shown with aftermarket upfit.

**THE BI-LINK REAR SUSPENSION.**

The Ram ProMaster City® rear suspension employs a steel crossmember with an optimum weight/stiffness ratio to help improve reaction to lateral loads. The results are confident hauling with enhanced stability and handling. Cargo-rated steel coil springs supply high-fatigue endurance, while a 16-mm solid stabilizer bar with optimized torsional stiffness helps ensure long-lasting durability.



**AGILITY AND CONTROL: STANDARD**



# READY IF CALLED UPON

## SEVEN STANDARD AIR BAGS<sup>11</sup> INCLUDING THE CLASS-EXCLUSIVE DRIVER-SIDE KNEE AIR BAG<sup>2,11</sup>

Our system includes dual-stage driver and front-passenger air bags,<sup>11</sup> supplemental side air bag<sup>11</sup> inflatable curtains, supplemental front-seat-mounted thorax air bags,<sup>11</sup> the driver-side knee air bag,<sup>11</sup> dual front seat belt pretensioners and seat belt load limiters. Wagon shown. Second-row seating not available in Cargo Van and supplemental driver- and front-passenger side-curtain air bags<sup>11</sup> only cover first row.

**7** STANDARD  
AIR BAGS<sup>11</sup>

**CLASS-EXCLUSIVE<sup>2,11</sup>**



# A PICTURE MAKES ALL THE DIFFERENCE



## **PARKVIEW® REAR BACK-UP CAMERA<sup>12</sup>**

The standard ParkView Rear Back-Up Camera<sup>12</sup> automatically shows the rear scene in the Uconnect® 3 with 5-inch touchscreen display when in Reverse. The on-screen grid lines help when backing up to docks and trailers or into parking spaces.

## **PARKSENSE® REAR PARK ASSIST SYSTEM<sup>13</sup>**

The standard ParkSense Rear Park Assist System<sup>13</sup> is an invaluable asset to help keep the driver alert to his or her surroundings. Activated under 8 mph when in Reverse, it detects objects up to 55 inches away (from the center of the rear fascia) and projects audible warnings that increase in intensity as the vehicle nears obstructions to the rear.





**FORWARD LIGHTING.**

Headlamps are mounted high above common damage areas to help reduce damage (and costs) in the event of a collision. The system includes the Follow Me Home function, keeping the headlamps lit for a preset time after the engine is shut down to help illuminate your path in the dark.



**ELECTRONIC STABILITY CONTROL (ESC).<sup>14</sup>**

Every Ram ProMaster City<sup>®</sup> boasts standard Electronic Stability Control (ESC).<sup>14</sup> This system integrates the Antilock Braking System (ABS) with a variety of All-Speed Traction Control technologies that enable all four corners of the vehicle to respond to lateral movement and the steering input from the driver. ESC<sup>14</sup> helps maintain control under conditions such as wet or snow-covered roads, during tight turns and when the driver must utilize evasive maneuvers to help counter the unexpected. Calibrated to engine output, ESC<sup>14</sup> includes four-channel ABS, Brake/Lock Differential, a full-function All-Speed Traction Control system, Brake Assist, Trailer Sway Damping,<sup>15</sup> Hill Start Assist and Electronic Roll Mitigation.<sup>14</sup>

**INTELLIGENT SECURITY DETAIL**



# 60/40

## SPLIT REAR DOORS



Shown with aftermarket upfit.



**OFFSET DOORS ARE DESIGNED TO BE SIMPLE AND CONVENIENT.** The 60/40-split rear doors were crafted so the larger door swings open toward the road. Not only does this design help shield workers from passing vehicles, it also prevents blocking the path to the curbside of the van. Both doors open 90 degrees initially and can swing out 180 degrees by pressing the release button on the door latch. The latch automatically re-engages when the door is closed.





## CRAFTED FOR MILES OF COMFORT



### STORAGE THAT KEEPS THE CLUTTER AWAY.

From the huge in-door pockets (with sculpted bottle holders) to specialized trays to oversized glove compartments, it's all here—even an overhead shelf, two 12-volt auxiliary power outlets, a USB port and connections to charge on-the-go electronics.





# TECHNOLOGY THAT CAN GET YOU THERE

## UCONNECT® 3 WITH 5-INCH DISPLAY

The standard Uconnect 3 with 5-inch color display radio system delivers true fidelity with easy-to-access info through Bluetooth® technology and the color touchscreen.



### UCONNECT 3 AT A GLANCE.

- AM/FM Stereo
- MP3 Capability with USB Input
- Integrated Voice Command
- 5-inch Color Touchscreen
- 4-speaker Sound System
- ParkView® Rear Back-Up Camera<sup>12</sup>

## UCONNECT 3 NAV WITH 5-INCH DISPLAY

The available Uconnect 3 NAV with 5-inch color display delivers precise, Web-based GPS Navigation.



### UCONNECT 3 NAV AT A GLANCE.

All features of the Uconnect 3 with 5-inch display, plus:

- GPS Navigation
- Points-of-interest Accessibility
- Turn-by-turn Navigation

Uconnect®





# RAM PROMASTER CITY<sup>®</sup> WAGON

**PERFECT FOR BUSINESSES, PERFECT FOR FAMILIES.** However you choose to use your Ram ProMaster City Wagon, we're committed to providing plenty of flexibility, convenience and comfort for the drive.





## PEOPLE, PLACES AND THINGS

**PACK FOR ADVENTURE.** Ram ProMaster City<sup>®</sup> Wagon is ready for adventure. The spacious interior comfortably seats five passengers. Dual side sliding doors provide easy access to rear seats, while the 60/40-split rear door design lets you load gear with ease. Whether you're hitting the campsite, the beach or somewhere in between, a 1,870-lb<sup>9</sup> towing rating lets you bring your toys along.

**LEAVE NO ONE BEHIND.** The confined spaces of the traditional family vehicle are long gone. The area behind Wagon's upright second-row seats is 74.1 cu ft<sup>9</sup>; fold them down, and the space opens up to 101.7 cu ft<sup>9</sup>.

Animals should always be safely and properly secured while vehicle is in motion.







## ROOM TO RELAX AND PACK

**AMPLE ROOM FOR PEOPLE AND CARGO.** If you think we didn't put thought into seating just because this is a wagon, we have some news to share. The tubular seats feature spring suspensions and adjustable headrests with reclining seatbacks and super durable fabrics.

Manual supports for the driver seat are standard, and heated surfaces for both front seats are available. Rear seats feature innovative Fold-and-Tumble operation with up to nine configurations. Impressive storage, huge cargo room and comfort for everyone make this the wagon of choice.





## UNCOMPROMISING FLEXIBILITY

**CONFIGURE THE RIGHT MIX.** With an interior this flexible, the only thing you're locked into is an interior that adapts to your needs. When rear seats are folded, you've got a cavernous 101.7 cu ft<sup>9</sup> of max cargo room. At full five-person occupancy, you still have a generous 74.1 cu ft<sup>9</sup> of cargo room behind the second-row seats.

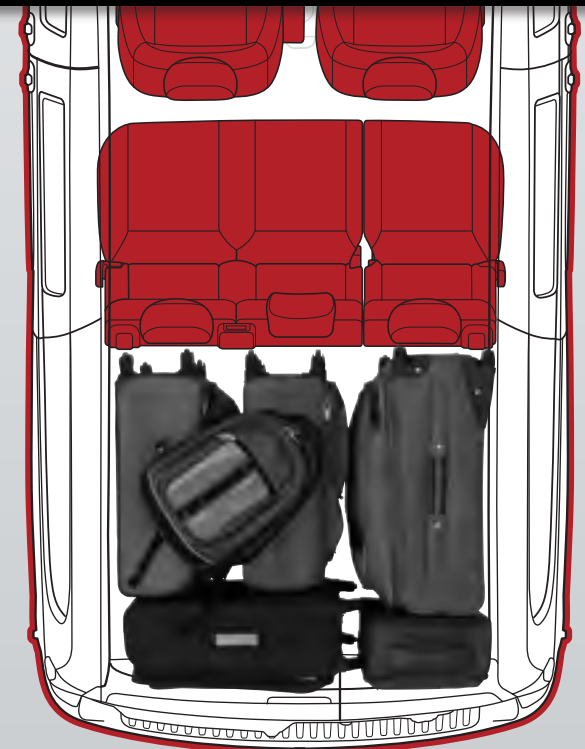
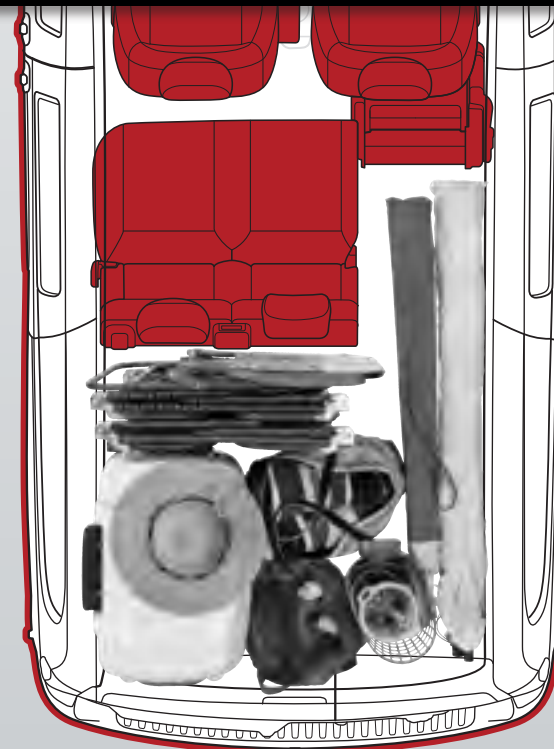
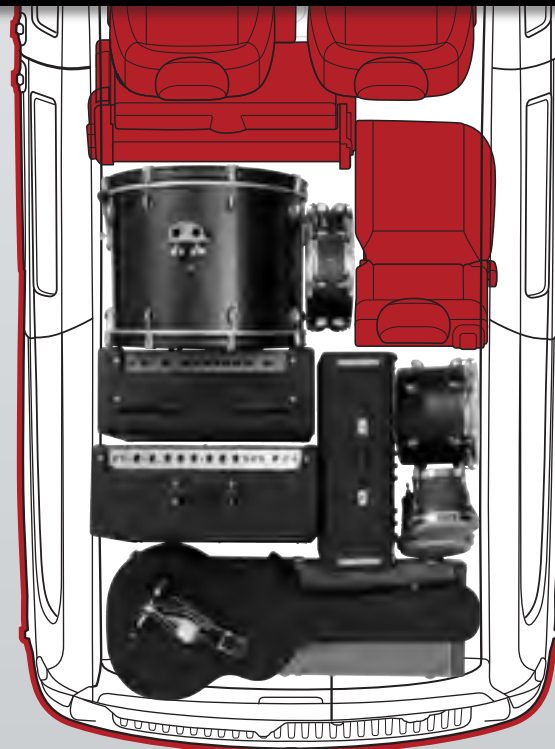
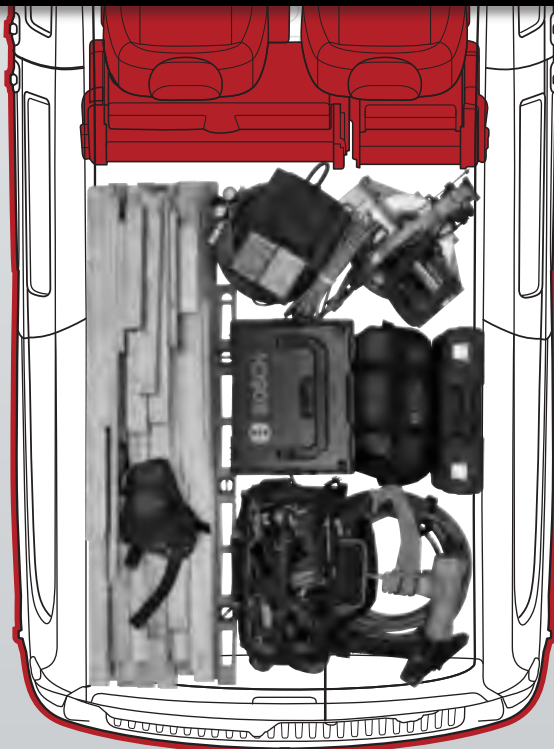



# ADAPT TO ALL POSSIBILITIES



**ADAPTIVE EQUIPMENT UPFITS.** The true measure of adaptability is to satisfy challenging demands with dignity, grace and style. Count on Ram ProMaster City® and the FCA DriveAbility Program to help you achieve it.

Expansive side door openings provide huge, unimpeded access to the interior. The flat floor and big 60/40-split rear doors make wheelchair access and mounting an apparatus simple. Standard in-floor D-rings (four on Wagon, six on Cargo Van) ensure secure anchoring—and incentives offered by the DriveAbility Program are pocketbook-friendly. Think comfort and operational ease—because our starting point was to make a van that's all about you.

Shown with aftermarket upfits.



# RAM PROMASTER CITY® BUYER'S GUIDE

## ENGINE/TRANSMISSION

2.4L Tigershark® MultiAir®2 I-4 engine/9-speed automatic transmission

SALES CODE  
Wagon  
Tradesman®  
Cargo Van

ED6/DFH • •

## MECHANICAL FEATURES

ALTERNATOR – 160-amp

BAB • •

BATTERY – 700-amp, maintenance-free

BC8 • •

BRAKES – 4-wheel antilock

BGK • •

FUEL TANK – 16-gallon

NFZ • •

UPFIT INTERFACE CONNECTOR

BC3 0 0

## EXTERIOR FEATURES

RAM GRILLE

ME6 • •

BODYSIDE MOLDING – Black

MJA • •

BUMPERS – Front and rear, body-color

MLA • •

DAYTIME RUNNING LAMPS

LMK • •

DOORS/WINDOWS – SEE COMPLETE CHART ON NEXT PAGE

– Window Group 01 - Includes rear hinged doors with fixed glass and sliding side doors with vented glass (Wagon models only)

GC4 • –

– Window Group 03 - Includes side and rear doors with solid panels

GC1 – •

– Window Group 04 - Includes left and right sliding door panels/rear doors with fixed windows

GC2 – 0

– Window Group 05 - Includes left and right sliding cargo doors with grates and vented glass/rear doors with fixed windows

GCY – 0

– Window Group 06 - Includes left and right sliding doors with vented side windows/rear doors with fixed windows (requires Cargo Partition Package - Solid or Cargo Partition Package - Window)

GC3 – 0

– Window Group 07 - Includes left sliding cargo door panel/right sliding door with grate and vented window/rear doors with fixed windows

GCP – 0

– Window Group 08 - Includes left sliding cargo door panel/right sliding cargo door with vented glass/rear doors with fixed windows (requires Cargo Partition Package - Window or Cargo Partition Package - Solid)

GCT – 0

– Rear doors with 180-degree opening

GLG • •

FOG LAMPS – Front (packaged with Lights and Wheels Group)

LNJ P P

GLASS – Deep-tint (included with Rear Wiper/Defroster and Deep-Tint Glass Group)

GEG P P

HEADLAMPS – Halogen

LMA • •

MIRRORS – Remote, manual-adjustable

GTZ • •

– Power-adjustable, folding, heated (included with Heated Seats and Power Mirror Group)

GTS P P

TIRES – 215/55R16XL BSW All-Season

TMC • •

WHEELS – 16-inch steel painted Silver with center cap

WDL/WME • •

– 16-inch aluminum (packaged with Lights and Wheels Group)

WDN P P

– Full-size spare tire (not available with Full-size Spare Tire and Inflator Kit)

TBB 0 0

– Full-size Spare Tire and Inflator Kit

ACF 0 0

– Tire Service Kit (includes puncture sealant and portable air compressor)

XAH • •

## INTERIOR FEATURES

AIR CONDITIONING

HAA • •

DOOR LOCKS – Power, speed-sensitive

JPH • •

FLOOR MATS – All-Weather Front and Rear (by Mopar®)

CLF 0 –

LIGHTING – Map/courtesy/cargo lamps

LBC • •

– LED Cargo Area Lighting (by Mopar)

LCP – 0

SEATS – 60/40-split Fold-and-Tumble 3-person rear bench

CFF • –

– Heated front (included with Heated Seats and Power Mirror Group)

JPM P P

– Premium cloth bucket with driver-side manual lumbar and height adjusters

\*C7 • •

SPEED CONTROL

NHM • •

STEERING COLUMN – Tilt/telescoping

SUD • •

STEERING WHEEL – Base

SCK • •

– Leather-wrapped with audio controls (included with Uconnect® 3 NAV with 5-inch display)

SCG P P

WINDOWS – Front, power with 1-touch up/down

JP3 • •

## UCONNECT MULTIMEDIA

UCONNECT 3 WITH 5-INCH DISPLAY – Includes AM/FM and Integrated Voice Command with Bluetooth®

UAA • •

UCONNECT 3 NAV WITH 5-INCH DISPLAY AND NAVIGATION – Includes AM/FM/NAV and leather-wrapped steering wheel with audio controls

UAB 0 0

SPEAKERS – 4

RCD • •

## SAFETY & SECURITY

AIR BAGS<sup>11</sup> – Driver and front-passenger

CGT/CGE • •

– Driver inflatable knee bolster

CGY • •

– Supplemental front-seat side

CJ1 • •

– Supplemental side-curtain for 1st and 2nd rows

CJ2 • –

– Supplemental side-curtain for 1st row

CJ4 – •

ELECTRONIC STABILITY CONTROL (ESC)<sup>14</sup> – Includes All-Speed Traction Control, Brake Assist, Brake-Lock Differential, Electronic Roll Mitigation,<sup>14</sup> Hill Start Assist and Trailer Sway Damping<sup>15</sup>

BNB • •

PARKSENSE® REAR PARK ASSIST SYSTEM<sup>13</sup>

XAA • •

PARKVIEW® REAR BACK-UP CAMERA<sup>12</sup>

XAC • •

REMOTE KEYLESS ENTRY

GXM • •

TIRE PRESSURE MONITORING (TPM) SYSTEM – Warning lamp

LAB • •

## PACKAGES/EQUIPMENT GROUPS

CARGO PARTITION PACKAGE – Solid - No window - Includes rear-wall trim (limited availability)

AS1 – 0

– With window - Includes rear-wall trim

AHA – 0

HEATED SEATS AND POWER MIRROR GROUP – Includes power heated mirrors and heated front seats

AGF 0 0

LIGHTS AND WHEELS GROUP – Includes front fog lamps and 16-inch aluminum wheels

AZK 0 0

MOPAR TRAILER TOW GROUP – Includes Class III hitch receiver with 4- and 7-pin wiring harness

AHT – 0

REAR WIPER/DEFROSTER AND DEEP-TINT GLASS GROUP – Includes rear window defroster, deep-tint sunscreen and rear window wiper/washer (must have Window Group 04, 05, 06, 07 or 08)

AMH 0 0

• = Standard 0 = Optional P = Available within Package – = Not available

For more information, visit [ram.com/promastercity](http://ram.com/promastercity)



# RAM PROMASTER CITY® DOOR/WINDOW CONFIGURATIONS

## CARGO VAN – NOT AVAILABLE WITH PARTITION

**GC1** (WINDOW GROUP 03)

**GC2** (WINDOW GROUP 04)

**GCY** (WINDOW GROUP 05)

**GCP** (WINDOW GROUP 07)

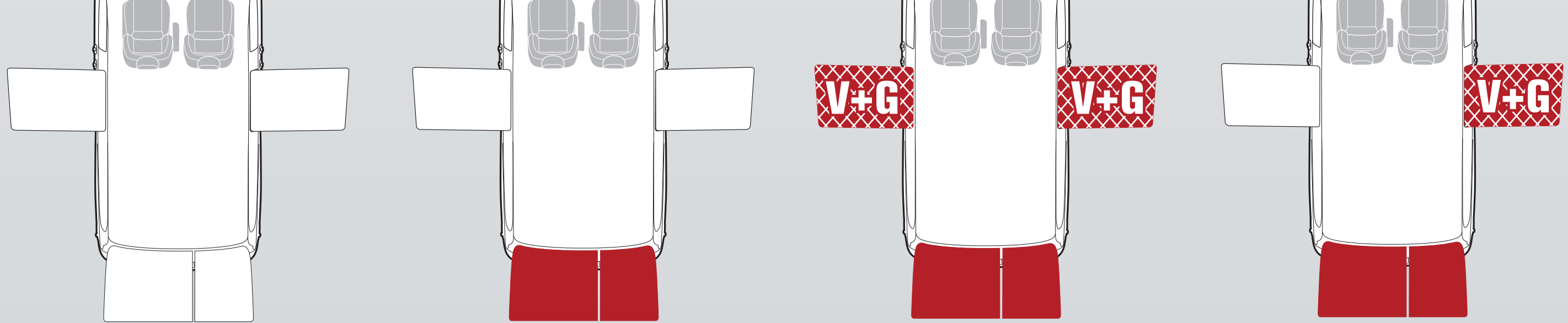

## CARGO VAN – REQUIRES PARTITION (AS1: solid partition; AHA: partition with window)

## WAGON

**GC3** (WINDOW GROUP 06)

**GCT** (WINDOW GROUP 08)

**GC4** (WINDOW GROUP 01)

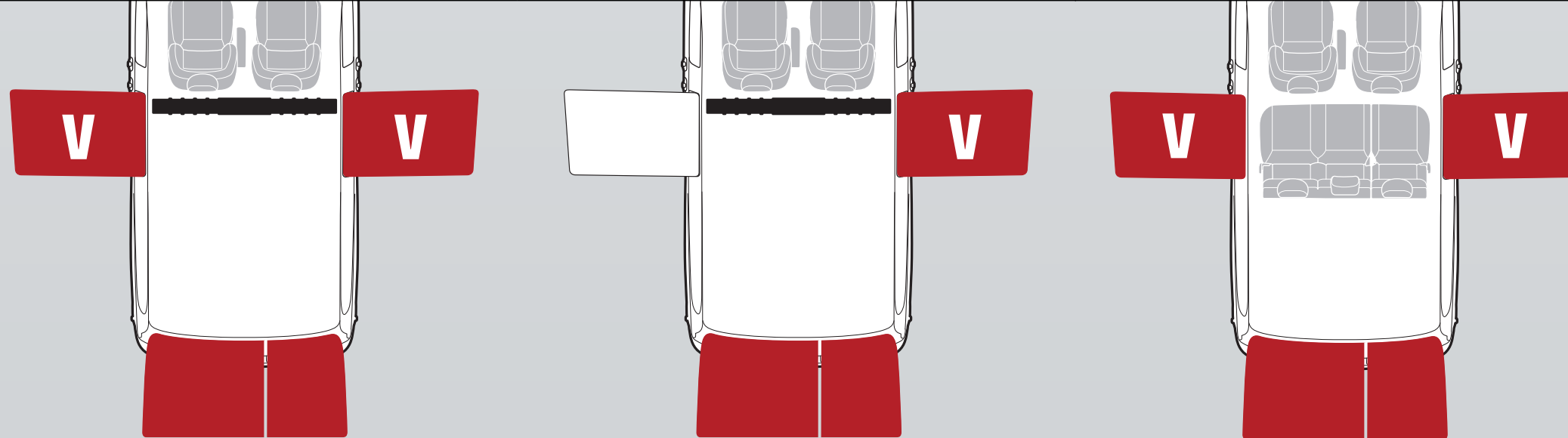

LEGEND				
				
SOLID PANEL	FIXED GLASS	VENTED WINDOW	VENTED WINDOW WITH GRATE	PARTITION

Due to Federal Safety Regulations (FMVSS), Ram ProMaster City Cargo Vans equipped with windows without grates must include a partition. Partitions are not necessary on windows with grates.

For more information, visit [ram.com/promastercity](http://ram.com/promastercity)



## RAM PROMASTER CITY® EXTERIOR COLORS



Bright White



Silver Metallic



Quartz Gray Metallic



Black



Bright Red



Deep Red Metallic



Blue Night Metallic

## INTERIOR FABRIC

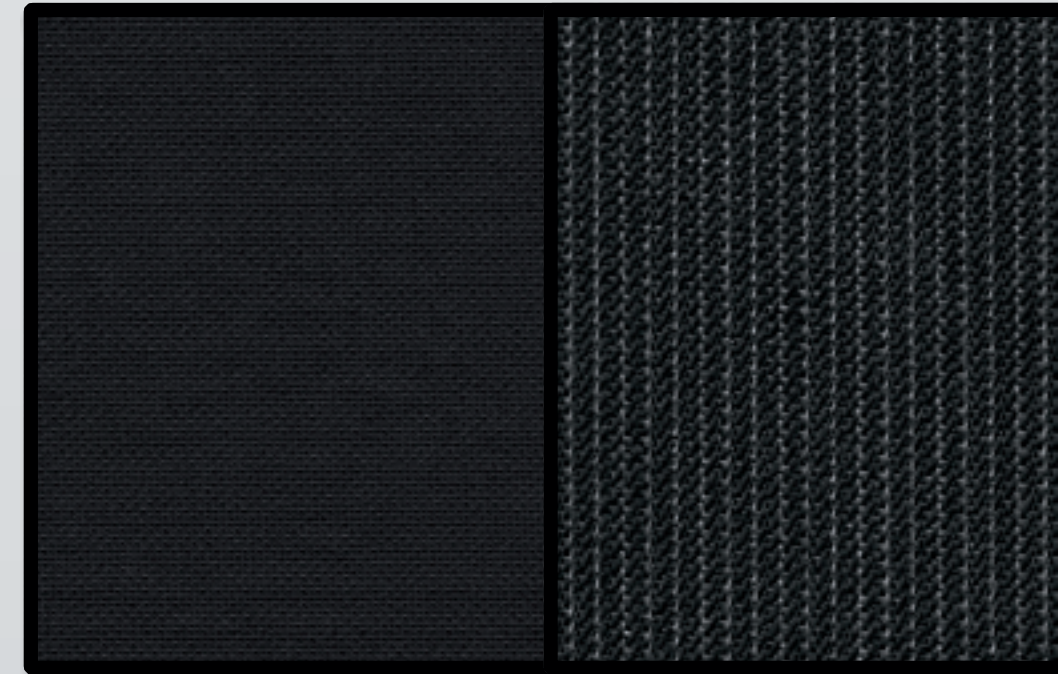

Premium Black Cloth  
Standard

## WHEELS

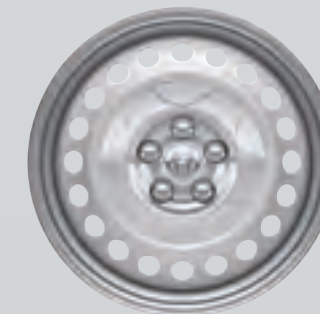

16-inch Steel Wheel  
painted Silver with Center Cap  
Standard



16-inch Aluminum Wheel  
Available on Tradesman® Cargo Van/Wagon

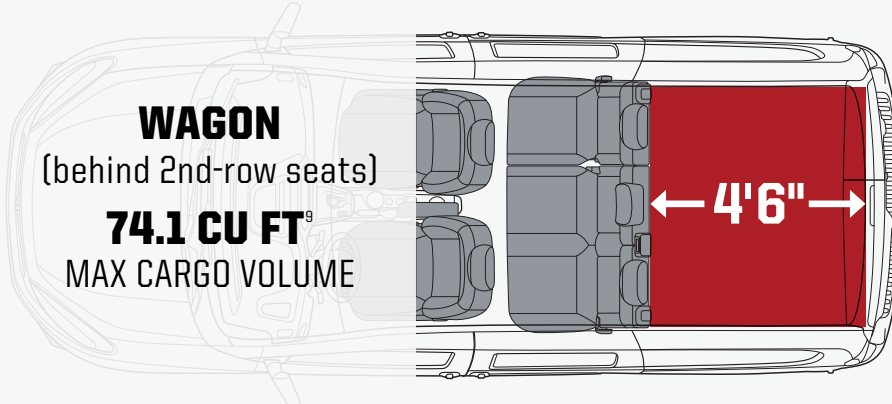
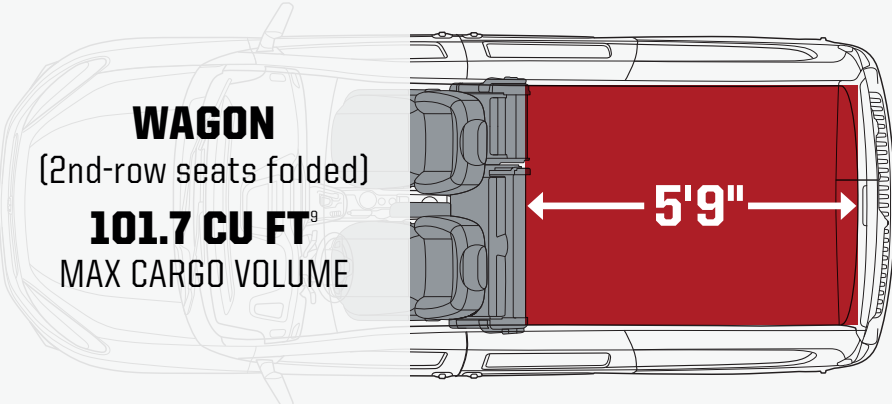
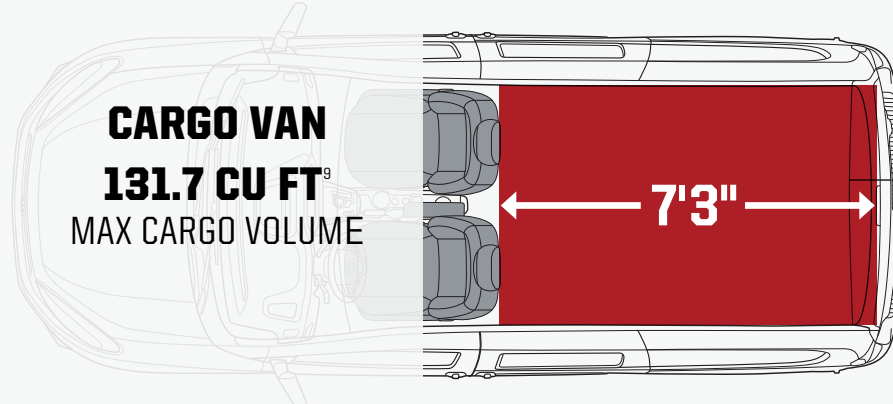

# RAM PROMASTER CITY® SPECIFICATIONS – WAGON & CARGO VAN

<b>DIMENSIONS</b> <small>(in inches unless otherwise noted)</small>	<b>WAGON</b>	<b>TRADESMAN® CARGO VAN</b>
<b>CARGO AREA – HEIGHT</b>	48.7	51.8
– LOAD FLOOR LENGTH <small>(behind 2nd-row seats on Wagon/2nd-row seats folded on Wagon)</small>	54.7/69.2	87.2
– VOLUME (cu ft) <small>(behind 2nd-row seats on Wagon/2nd-row seats folded on Wagon)</small>	74.1/101.7	131.7
 <p><b>WAGON</b> <small>(behind 2nd-row seats)</small> <b>74.1 CU FT<sup>9</sup></b> MAX CARGO VOLUME</p> <p>← 4'6" →</p>	 <p><b>WAGON</b> <small>(2nd-row seats folded)</small> <b>101.7 CU FT<sup>9</sup></b> MAX CARGO VOLUME</p> <p>← 5'9" →</p>	 <p><b>CARGO VAN</b> <b>131.7 CU FT<sup>9</sup></b> MAX CARGO VOLUME</p> <p>← 7'3" →</p>
<b>DOOR OPENING HEIGHT – REAR CARGO</b>	46.4	47.4
– SIDE SLIDING	42.7	43.6
<b>DOOR OPENING WIDTH – REAR CARGO</b>	48.6	48.6
– SIDE SLIDING	21.2	25.8
<b>HEAD ROOM – 1ST ROW</b>	45.8	45.8
– 2ND ROW	44	–
<b>HEIGHT – OVERALL</b>	74.2	74.2
<b>HIP ROOM – 1ST ROW</b>	52.8	52.8
– 2ND ROW	59.2	–
<b>LEG ROOM – 1ST ROW</b>	40.8	40.8
– 2ND ROW	36.8	–
<b>LENGTH – OVERALL BODY</b>	187.1	187.1
<b>REAR DOOR LIFT-IN HEIGHT</b>	23.8	23.3
<b>SIDE DOOR STEP-IN HEIGHT</b>	19.3	21.5
<b>WHEELBASE</b>	122.4	122.4
<b>WIDTH – BETWEEN WHEEL WELLS</b>	48.4	48.4
– MAXIMUM BETWEEN SIDE PANELS	57.6	60.4
– VEHICLE (including mirrors)	84.6	84.6





### THE DEALER NETWORK FOR YOUR BUSINESS.

Your **BusinessLink** dealer is committed to providing you, the small business owner, with the vehicle support you need for your business, from servicing all makes and models of your existing lineup to selling you the right vehicles needed to perform the work that you do. Your **BusinessLink** dealer provides priority service because we know downtime is costing you money. **BusinessLink** sales professionals are trained to properly “job-rate” the right vehicle for your work application and provide commercial finance options. New vehicle sales to qualified small business owners also include a free alternate transportation contract, in the event your vehicle is in for service.

Membership is free. Membership helps us to identify you as a small business owner so we can provide you with both the service you deserve and update you with offers that can help reduce the cost of doing business. Ask your **BusinessLink** dealer to register today.

**BusinessLink** has you covered.

- Full Range of FCA Commercial Vehicles
- Free Membership
- Priority Service
- Extended Service Hours
- Dedicated Staff of Commercial Vehicle Experts
- Free Alternate Transportation
- Commercial Incentives
- Expertise in Commercial Financing Options
- 24/7 Towing Service Available

For more information, go to [fcausfleet.com/programs/business-link-dealers.html](http://fcausfleet.com/programs/business-link-dealers.html) or call us toll-free at **877-2THELINK (877-284-3546)**.

# MAXIMIZE YOUR EXPERIENCE



### INCENTIVES FOR SMALL BUSINESSES.

Running a business presents plenty of challenges. Like cutting costs, not corners. Like saving time and money while avoiding hassles. The **ON THE JOB**<sup>16</sup> commercial incentive program provides assistance in customizing and servicing your business vehicles.

**ON THE JOB**<sup>16</sup> allowances make your business more profitable!

- UP TO \$1,000 Commercial Graphics Program Allowances<sup>17</sup>
- UP TO \$1,000 Commercial Equipment/Upfit Allowances<sup>18</sup>



A commercial line of credit from Chrysler Capital is ideal for qualified business customers looking for a flexible, easy way to manage growing vehicle needs. Chrysler Capital streamlines the process—and with prequalification, you’re ready to buy a vehicle when you need it. Ask your **BusinessLink** dealer for details.





**BORN UNDER THE RAM LOGO.** Drive a pickup with total street cred—and then take it to the next level. Here is where you'll find an exclusive collection of the useful, the cool and the stylish—from clothing and caps to coolers and tools. Make the Ram identity part of your everyday lifestyle.



OFFICIAL BRANDED MERCHANDISE SITE  
[ram.com/outfitter](http://ram.com/outfitter)

Ram Truck owners view their trucks as more than transportation, but as an extension of themselves. Check out an exclusive line of gifts and accessories for the Ram Truck enthusiast. From authentic apparel to rugged work gear, as well as electronics and office supplies, all lifestyle items are as distinctive as your Ram Truck.

available at  
**amazon**

[amazon.com/ramtruckstore](http://amazon.com/ramtruckstore)





For more information, visit [ram.com/promastercity](https://ram.com/promastercity)



1 Based on best-in-class cargo capacity, best-in-class payload and best-in-class hwy mpg. EPA-estimated 28 hwy mpg. Class is Small Commercial Van segment (Class 1). 2 Class is Small Commercial Van segment (Class 1). 3 Class is Small Commercial Van Segment (Class 1). EPA-estimated 28 hwy mpg, 2.4L automatic 9-speed transmission. Actual mileage may vary. 4 Class is Small Commercial Van segment (Class 1). When properly equipped. 5 Based on manufacturer testing. Always drive carefully, consistent with conditions. Always wear your seat belt and obey posted speed limits. 6 Cargo volume behind first-row seat. Class is Small Commercial Van segment (Class 1). 7 Visit Mopar.com for complete details and a copy of the Powertrain Limited Warranty. 8 Assumes properly equipped vehicle and 150-lb allowance for driver. Additional options, equipment, passengers and cargo weight must be subtracted. See dealer for details. 9 When properly equipped. See dealer for details. 10 Check Owner's Manual for hitch types, load capacity and heavy-duty equipment required. Do not exceed rated tow capacity of the vehicle as equipped. Trailer may require items not supplied by Mopar. 11 Always sit properly in designated seating positions with seat belts securely fastened at all times. 12 Always check entire surroundings visually before proceeding. 13 Always look before proceeding. An electronic drive aid is not a substitute for conscientious driving. Always be aware of your surroundings. 14 Always drive carefully, consistent with conditions. Always wear your seat belt and obey traffic laws. 15 Always drive carefully, consistent with conditions. 16 ON THE JOB is a retail incentive program; see your dealer for official rules. Inquire about eligibility by calling 877-ONTHEJOB or by logging on to [fcausfleet.com/programs/business-link-dealers.html](https://fcausfleet.com/programs/business-link-dealers.html). The purchaser or lessee must be a qualified commercial customer for more than 30 days prior to the date of the vehicle purchase. An official ON THE JOB Customer Acknowledgment Form must be signed by the customer (provided by the dealer). 17 Allowance varies by graphic program. See dealer for details. Take retail delivery by 01/03/2023. 18 Allowance varies by upfit and model. See dealer for details. Take retail delivery by 01/03/2023.

©2022 FCA US LLC. All Rights Reserved. Ram, Mopar, the BusinessLink design, ParkSense, ParkView, the Ram's Head logo, Ram ProMaster City, Tigershark, Tradesman and Uconnect are registered trademarks, and DriveAbility & design and On The Job & design are trademarks of FCA US LLC. Chrysler Capital is a registered trademark of FCA US LLC and licensed to Santander Consumer USA Inc. MultiAir is a registered trademark of C.R.F. Società Consortile per Azioni, used under license by FCA US LLC.

Bluetooth is a registered trademark of Bluetooth SIG, Inc. Sirius XM Connected Vehicles Services Inc. Sirius, XM and SiriusXM and all related marks and logos are trademarks of Sirius XM Radio Inc. Facebook and logo are registered trademarks of Facebook, Inc. The Twitter logo is a service mark of Twitter, Inc. YouTube and other marks are registered trademarks of Google LLC. Instagram and logo are registered trademarks of Instagram, Inc. Katerack is a registered trademark of Dejana Truck & Utility Equipment Co. All rights reserved. LinkedIn, the LinkedIn logo, the IN logo and InMail are registered trademarks or trademarks of LinkedIn Corporation and its affiliates in the United States and/or other countries. TikTok is a trademark of ByteDance Ltd. NEXEN is a trademark of Nexen Tire Corporation. Amazon and all related logos and marks are trademarks of Amazon.com, Inc. or its affiliates.

About this catalog: since the time of publication, some of the information you'll find in this catalog may have been updated. Ask your dealer for details. Some of the equipment shown or described throughout this catalog may be available at extra cost. Specifications, descriptions, illustrative materials and all competitive comparisons contained herein are as accurate as known at the time this publication was approved. FCA US LLC reserves the right to discontinue models at any time or change specifications without notice or without incurring obligation. Options may be required in combination with other options. For the price of the model with the equipment you desire, or verification of specifications contained here, see your Ram dealer.



Join fellow Ram enthusiasts and tell your story by posting comments, participating in discussions, and sharing your photos and videos. Join our community on Facebook, Twitter, YouTube, TikTok, Instagram and LinkedIn.

Explore Ram Life at [ram.com/ram-life.html](https://ram.com/ram-life.html)

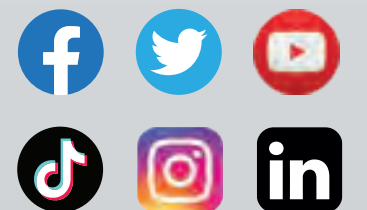

Ram is a registered trademark of FCA US LLC.

74-383-2228\_04/22