



**2022 RAM PROMASTER**

# ONE VAN. MANY POSSIBILITIES.

What do you get when you add four cargo lengths, availability in three weight classes, two roof heights, three wheelbases, an open cargo area that can be upfitted countless ways and a new interior? One perfect cargo van for you—the 2022 Ram ProMaster.<sup>®</sup> You also get the legendary capability that's built into every Ram Truck. This is a business partner you can count on. [ram.com/promaster](https://ram.com/promaster)



Shown with aftermarket upfits.



# CONTENT LEGEND

CLAIMS .....	4-5	INTERIOR VERSATILITY .....	24
NEW INTERIOR .....	6	MOPAR® ACCESSORIES .....	25-26
SAFETY & SECURITY .....	7-13	POWERTRAIN .....	27
CARGO WIDTH .....	14	PERFORMANCE .....	28-29
CARGO HEIGHT .....	15	CHASSIS CAB .....	30-31
CARGO LENGTH .....	16	WINDOWED VAN .....	32
PAYLOAD TIE-DOWNS .....	17	BUYER'S GUIDE .....	33-35
CARGO VAN PAYLOAD .....	18	EXTERIOR COLORS .....	36
PAYLOAD CAPACITY .....	19	INTERIOR FABRICS .....	36
INTERIOR LIGHTING .....	20	WHEELS .....	37-38
UCONNECT®/RADIOS .....	21	SPECIFICATIONS .....	39
NEW CREW VAN PACKAGE .....	22	VEHICLE CONFIGURATIONS .....	40
SEAT CONFIGURATIONS .....	23	BUSINESS SUPPORT .....	41
		RAM MERCHANDISE .....	41
		DISCLOSURES/RAM SOCIAL .....	42

Shown with aftermarket upfit.

# ADVANTAGE: RAM PROMASTER<sup>®</sup>

## **CLASS-EXCLUSIVE**

**FWD**  
**FRONT-WHEEL-DRIVE SYSTEM<sup>1\*</sup>**  
Excels in adverse weather conditions

## **BEST-IN-CLASS**

**4,680-LB**  
**MAXIMUM PAYLOAD<sup>2</sup>**  
(3500 Cargo Van, 136-inch wheelbase,  
Standard Roof)

## **BEST-IN-CLASS**

**36.3-FT**  
**TURNING DIAMETER<sup>1</sup>**  
(118-inch-wheelbase Cargo Van models)

AVAILABLE  
**DIGITAL REARVIEW  
MIRROR**

STANDARD  
**FULL-SPEED FORWARD  
COLLISION WARNING PLUS  
WITH  
PEDESTRIAN EMERGENCY  
BRAKING<sup>3</sup>**

AVAILABLE  
**BLIND SPOT MONITORING<sup>4</sup>**  
WITH  
**REAR CROSS-PATH DETECTION<sup>5</sup>**

STANDARD  
**ESC**  
**ELECTRONIC STABILITY  
CONTROL<sup>6</sup>**

STANDARD V6 HORSEPOWER  
**276 HP**  
(with 250 lb-ft of torque)



\*All disclosures can be found on the last page.

# DESIGNED FOR EASY ACCESS



Shown with aftermarket upfit.

## BEST-IN-CLASS

**75.6-INCH**  
MAXIMUM CARGO WIDTH<sup>1</sup>  
(Cargo Van)

## BEST-IN-CLASS

**66.9-INCH**  
STANDARD CARGO HEIGHT<sup>1</sup>  
(Cargo Van with standard roof)  
(Cargo Van shown here with available High Roof  
has a 77.1-inch cargo height)

## BEST-IN-CLASS

**56.0-INCH**  
CARGO WIDTH BETWEEN  
THE WHEEL WELLS<sup>1</sup>  
(Cargo Van)

## BEST-IN-CLASS

**LOWEST LOAD  
FLOOR HEIGHT<sup>1</sup>**  
(Cargo Van)

## TALLEST & WIDEST

STANDARD CARGO AREA IN ITS CLASS<sup>1</sup>  
(Cargo Van with standard roof)  
(Cargo Van shown here with available  
High Roof has a 77.1-inch cargo height)

STANDARD UCONNECT® 5C WITH  
**7-INCH**  
TOUCHSCREEN DISPLAY

# A PREMIUM WORKSPACE

7-inch Digital Cluster—Available

Leather-wrapped Steering Wheel—Available

Uconnect® 5C NAV with 10.1-inch Radio—Available

Electronic Parking Brake

Push-button Start

Steering Wheel Switch Banks

2 USB Ports—Type A and C

115-volt Outlet—Available

12-volt Charging Socket

Wireless Phone Charging Pad—Available

**COMFORTABLE, ACCOMMODATING, CAPABLE.** Ram ProMaster® is engineered to withstand mile after mile of rigorous work with an interior crafted to reward drivers for all the hours they clock too. This upscale interior was inspired by the available luxury in the Ram Pickups and focuses on refined appearance, next-generation technology, and an even greater concentration on comfort and convenience. New interior packages bundle customer-favorite features and capabilities.

## AVAILABLE CONVENIENCE PACKAGES:

- Premium RV Group
- Premium Convenience Group
- Driver Convenience Group
- Crew Van Package

# MANEUVER WITH EASE



**KEEP YOUR BUSINESS ON THE MOVE.** Ram ProMaster® delivers the trifecta of work van perfection: dynamic capability, impressive interior space, and the maneuverability to navigate jobsites and tight city streets. Count on the wide array of standard and available features that help make driving a ProMaster as satisfying as putting in a full day's work.



STANDARD PARKVIEW® REAR BACK-UP CAMERA<sup>3</sup> WITH DYNAMIC GRID LINES

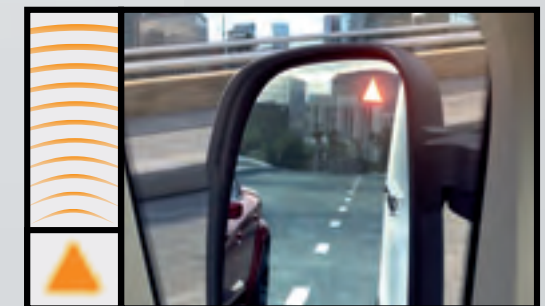

AVAILABLE BLIND SPOT MONITORING (BSM)<sup>4</sup> WITH REAR CROSS-PATH DETECTION<sup>5</sup> AND SIDE-MIRROR NOTIFICATION SIGNAL LIGHT



AVAILABLE PARKSENSE® FRONT AND REAR PARK ASSIST<sup>7</sup>



AVAILABLE 360° SURROUND-VIEW CAMERA SYSTEM<sup>5</sup>

# A GOOD OFFENSE IS THE BEST DEFENSE

## SURROUNDED BY TECHNOLOGY.

Ram ProMaster® is designed to help drivers anticipate the unexpected. Advanced standard and available Safety and Security systems can help warn the driver of potential hazards and avoid accidents. This van's protection plan includes the standard and available features that can help recognize traffic signs, detect a drowsy driver, assist with speed control and apply the brakes if needed.

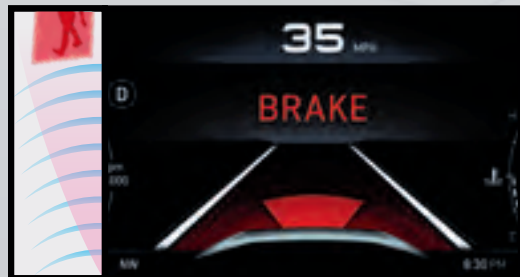
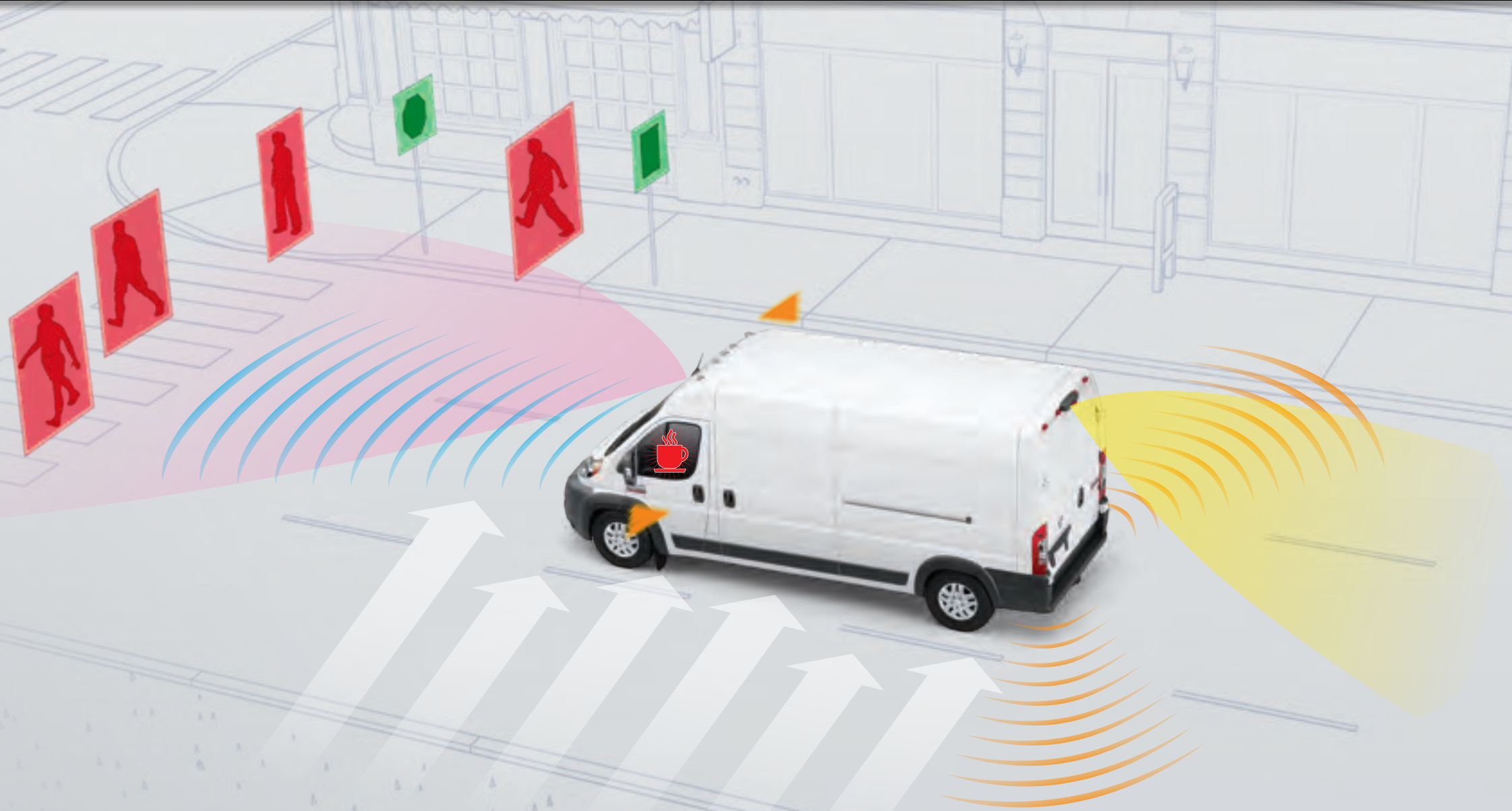

STANDARD FULL-SPEED FORWARD COLLISION WARNING PLUS WITH PEDESTRIAN EMERGENCY BRAKING<sup>3</sup>



STANDARD TRAFFIC SIGN RECOGNITION<sup>8</sup>  
(optional color cluster shown)



STANDARD DROWSY-DRIVER DETECTION<sup>9</sup>



STANDARD CROSSWIND ASSIST

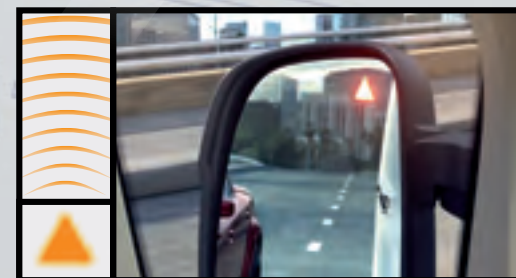

AVAILABLE BLIND SPOT MONITORING (BSM)<sup>4</sup>  
WITH REAR CROSS-PATH DETECTION<sup>5</sup> AND  
SIDE-MIRROR NOTIFICATION SIGNAL LIGHT

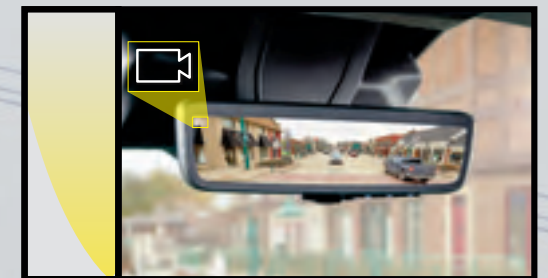

AVAILABLE  
DIGITAL REARVIEW MIRROR



# CONFIDENCE AND SECURITY



## **AVAILABLE BLIND SPOT MONITORING (BSM)<sup>4</sup> WITH REAR CROSS-PATH DETECTION.<sup>5</sup>**

With dual wide-band radar sensors in the rear of the vehicle, the available BSM<sup>4</sup> with Rear Cross-Path Detection<sup>5</sup> scans the blind-spot zones behind the vehicle to help ensure safe maneuvering.

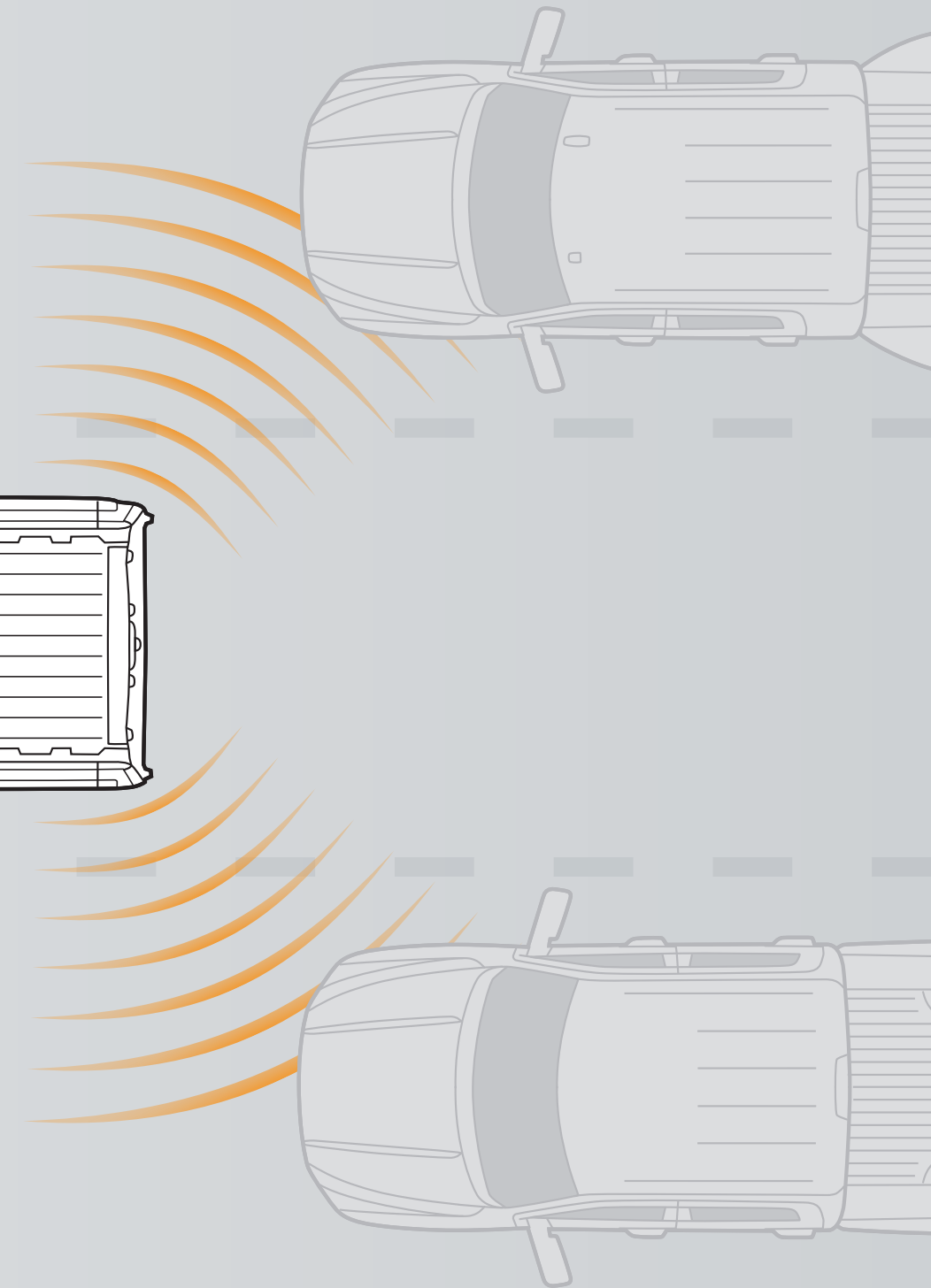
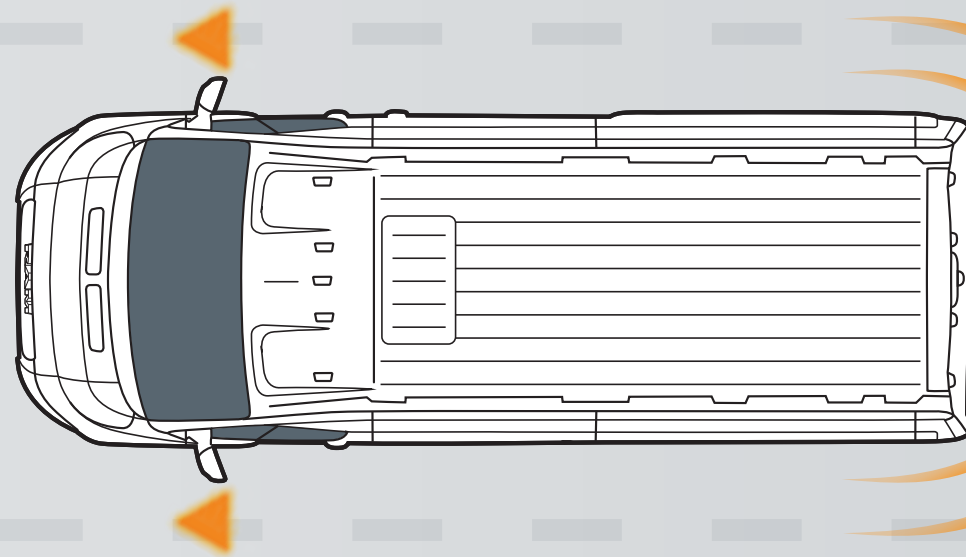

MONITORING SAFE AREA AHEAD



SENSING POSSIBLE OBSTRUCTION

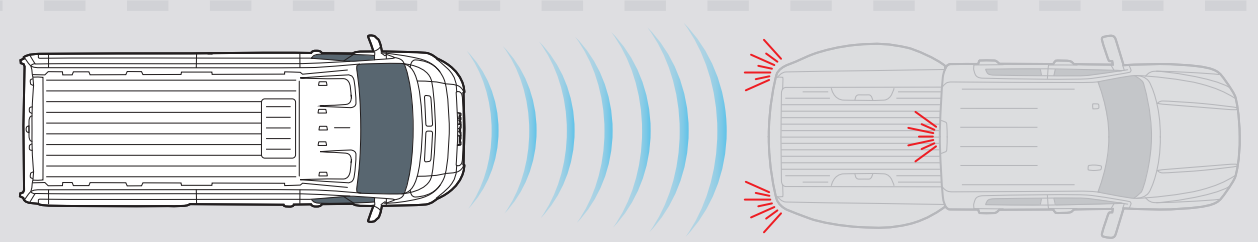

# FORWARD-THINKING PROTECTION

## STANDARD FULL-SPEED FORWARD COLLISION WARNING PLUS WITH PEDESTRIAN EMERGENCY BRAKING<sup>3</sup>

The Full-Speed Forward Collision Warning Plus (FSFCW+) with Pedestrian Emergency Braking<sup>3</sup> system provides both audible and visual warnings to help alert the driver when it detects a potential frontal collision. The warnings are intended to help provide the driver with enough time to react to, avoid or mitigate the potential collision.

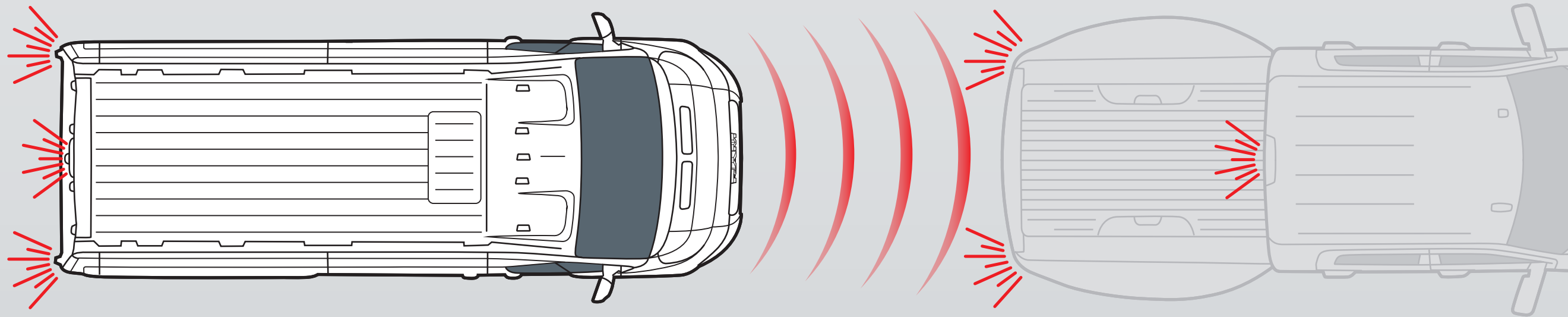

# BRAKE!

# NO MORE OBSTRUCTED VIEWS



## AVAILABLE **DIGITAL REARVIEW MIRROR**



**HELPING YOU SEE MORE.** The available Digital Rearview Mirror replaces a traditional reflective rearview mirror with a 9.2-inch-wide LCD monitor that displays real-time video from a rear-facing camera. The camera is located on the back of the van, so the view is unobstructed compared to a traditional rearview mirror. Unlike back-up cameras, the vehicle doesn't need to be in Reverse to activate, and the view is high resolution.

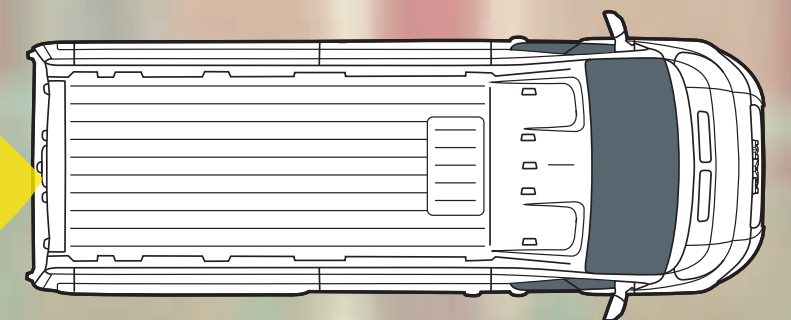

# TECHNOLOGY AT EVERY TURN



**ADVANCED SAFETY GROUP.** The available Advanced Safety Group includes features designed to help drivers anticipate the unexpected.

# POWERED BY PEACE OF MIND

## **MULTI-COLLISION BRAKING.**

In the event that a collision does occur, this system moderately applies the brakes after impact to stop the vehicle from rolling and to help avoid a potential second accident. The system knows to trigger the brakes by interacting with the seat restraint modules, including whether an air bag<sup>10</sup> is deployed or if the fuel cutoff switch is activated. By applying the brakes right away, the system helps prevent further damage or injury which could occur through the continuing motion of the vehicle due to the crash moment. Standard.

## **INTELLIGENT SPEED ASSIST (ISA).**

Through a speed-sign-recognition video camera and/or GPS-linked speed limit data via the available navigation system, ISA alerts drivers of the current speed limit and automatically adjusts the speed of the vehicle as needed. As the ISA system reads changing speed limit signs, the throttle is adjusted to stay within the speed limit (or an acceptable +/- offset). Available.

## **LANESENSE® LANE DEPARTURE WARNING PLUS.<sup>11</sup>**

Via its forward-facing camera, the Ram ProMaster® LaneSense Lane Departure Warning Plus<sup>11</sup> system is designed to identify the lines on the road. The system then determines where the vehicle is placed between the lines and monitors the vehicle's movement down the road. Available.



**ADAPTIVE CRUISE CONTROL WITH STOP AND GO.<sup>9</sup>** The system uses a radar sensor and forward-facing camera mounted at the front of the vehicle to help detect objects in its path. If the lane ahead is clear, the system will maintain the set speed. When slower traffic is detected, the system is designed to automatically adjust to a safe distance (which is selected by the driver) by using throttle control and limited braking. Available (late availability).

**RAIN-SENSITIVE WINDSHIELD WIPERS.** A glass-mounted infrared sensor located near the rearview mirror continually sends infrared beams against the windshield to detect raindrops. Once detected, the system's control strategy signals the wipers to operate and adjusts wiper speed based on rain accumulation. Available.

**AUTOMATIC HEADLAMPS.** A forward-facing camera and rain/dusk sensor can process images to detect oncoming or forward lights. When these components detect an approaching vehicle's headlights, preceding vehicle's taillamps or ambient light, the system turns off the high beams before it distracts other drivers. Available.

**CORNERING FUNCTION FOG LAMPS.** Refinements in the relating lens elements help ensure wider spread light and improved accuracy when the steering wheel is turned and while turn signals are activated. As a result, the fog lamps are designed to provide additional illumination when cornering. Available.

**HEAVY-DUTY ANTILOCK BRAKING SYSTEM (ABS).** All 2022 Ram ProMaster offerings are equipped with heavy-duty brake systems that are designed to deliver impressive stopping power. Included are large-diameter-sized four-wheel heavy-duty disc brakes with thick pads for projected long-term durability. Standard.

**ELECTRONIC STABILITY CONTROL (ESC).<sup>6</sup>** The Ram ProMaster ESC<sup>6</sup> features a sophisticated four-channel (independent control to all four corners of the vehicle) active handling system. The ESC<sup>6</sup> system links the vehicle's dynamic control systems to assist the driver in maintaining control under demanding or adverse conditions, such as wet, snow-covered or icy roads, and during tight turns and evasive maneuvers. Standard.

## **NEW AVAILABLE SAFETY AND SECURITY PACKAGES**

### **ADVANCED SAFETY GROUP**

- Wide, Power-Heated Mirrors or Power-Folding Heated Mirrors
- Intelligent Speed Assist
- LaneSense Lane Departure Warning Plus<sup>11</sup>
- 7-inch Full-Color Thin Film Transistor (TFT) Center Cluster Display
- Cornering Functional Fog Lamps
- Active Drive Assist System
- Leather-Wrapped Steering Wheel
- 360° Surround-View Camera System<sup>5</sup>
- Blind Spot Monitoring<sup>4</sup> with Rear Cross-Path Detection<sup>5</sup>
- Adaptive Cruise Control with Stop and Go<sup>9</sup> (late availability)

### **SAFETY GROUP**

- Digital Rearview Mirror with Auto-Dimming
- Power-Folding Heated Mirrors
- Cornering Functional Fog Lamps
- Daytime Running Headlamps
- ParkSense® Rear Park Assist System<sup>7</sup>
- Blind Spot Monitoring<sup>4</sup> with Rear Cross-Path Detection<sup>5</sup>

### **LANE MANAGEMENT GROUP**

- Wide, Power-Heated Mirrors or Power-Folding Heated Mirrors
- LaneSense Lane Departure Warning Plus<sup>11</sup>
- Blind Spot Monitoring<sup>4</sup> with Rear Cross-Path Detection<sup>5</sup>

# THE RIGHT WIDTH FOR THE RIGHT FIT



**WIDE-OPEN ACCESS.** Regardless of which 2022 Ram ProMaster® model you choose, fitting a standard pallet between the wheel wells won't be an issue. Need a shelf system? With 6 ft 3 in of interior width and near vertical walls, that won't be an issue either. The cavernous space inside ProMaster is also the perfect space for transporting equipment and materials or creating a mobile work area.



**THE RIGHT HEIGHT FOR THE RIGHT FIT.**

Ram ProMaster® wasn't designed just to fit cargo, it was designed to fit people too. With this best-in-class standard cargo height,<sup>1</sup> convenience is built in. Opt for the available High Roof and you have a rear workspace that most people can walk in without stooping or bending over.



STANDARD ROOF: **BEST-IN-CLASS** STANDARD CARGO HEIGHT<sup>1</sup> (CARGO VAN)

# BEST-IN-CLASS STANDARD CARGO HEIGHT



AVAILABLE HIGH ROOF



159-inch wheelbase, extended

## FOUR LENGTHS TO MEET MANY NEEDS



159-inch wheelbase



136-inch wheelbase



118-inch wheelbase

**ONE SIZE DOES NOT FIT ALL.** The size of your product, the amount of gear needed and the area of your parking space are specific to your business. We know that, and it's the reason why we offer Ram ProMaster® Cargo Van in four lengths. Along with the superwide width, choose from two available roof heights and four lengths built on three wheelbases. Our goal is to always give you multiple possibilities in terms of adaptability, convenience and aftermarket upfit.



# OPERATE AT FULL CAPACITY



CARGO VAN PAYLOADS (weight given in lb)	1500			2500			3500			
	118" WB	136" WB		136" WB		159" WB	136" WB		159" WB	159" WB, EXT.
	STANDARD ROOF	STANDARD ROOF	HIGH ROOF	STANDARD ROOF	HIGH ROOF	HIGH ROOF	STANDARD ROOF	HIGH ROOF	HIGH ROOF	HIGH ROOF
<b>MAX PAYLOAD<sup>12</sup></b>	<b>4,010</b>	<b>3,910</b>	<b>3,800</b>	<b>4,260</b>	<b>4,150</b>	<b>4,000</b>	<b>4,680</b>	<b>4,560</b>	<b>4,430</b>	<b>4,430</b>

WB = wheelbase. Best-in-class<sup>2</sup> = 0,000

# MANAGE CARGO LIKE A PRO

**SMART CARGO MANAGEMENT—JUST HIT THE ROOF.** Maximize potential and expand cargo-carrying capability. Cargo Van roof strength can handle up to 330 lb.<sup>12</sup> Six roof mounting points (three per side) enable the aftermarket roof rack of choice.

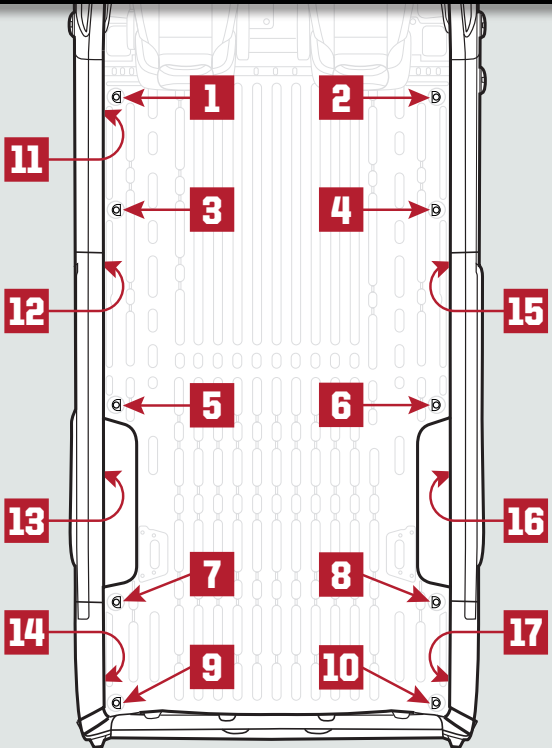

159-inch wheelbase, extended

**UP TO 17 AVAILABLE WALL AND FLOOR CARGO TIE-DOWNS.** Cargo Van models feature up to 10 in-floor D-rings to help secure cargo. Want more? Up to an abundant 17 floor and sidewall tie-downs provide stabilization and security for your cargo when you're on the move.





**PACK IT UP AND PACK IT IN.** With up to 462.9 cu ft of cargo capacity,<sup>12</sup> a 4,680-lb maximum payload<sup>12</sup> and easy access to the cargo area, Ram ProMaster® makes light of heavy work.



**BEST-IN-CLASS**  
LOWEST LOAD FLOOR HEIGHT<sup>1</sup>

## DESIGNED TO DELIVER

**LOW LOAD FLOOR HEIGHT.** Our Front-Wheel Drive (FWD) and robust beam axle/leaf spring rear suspension eliminate the middle hump typical of Rear-Wheel-Drive (RWD) vehicles, giving you an easy-to-load, low load floor height.



# MOBILE WORKSTATION

**THE AVAILABLE AMBIENT LED INTERIOR LIGHTING.** Whether you're working during daylight hours or in the hours most people are sleeping, having a well-lit workspace is important. Opt for the available Ambient LED Interior Lighting; it helps illuminate the foot wells, dash trim, vehicle controls and more.

# TECHNOLOGY AT YOUR FINGERTIPS

The standard Uconnect® 5C comes with a 7-inch touchscreen, while the available Uconnect 5C NAV features a 10.1-inch touchscreen with Navigation. Both technology hub options boast impressive processing power and dual smartphone Bluetooth® connectivity. They also feature personalization options, such as profiles that save your settings, useful home screen widgets and comfort control. These advanced and intuitive systems help you stay connected, informed and entertained while on the job.

## UCONNECT 5C WITH 7-INCH DISPLAY.

### UCONNECT 5C AT A GLANCE:

- 7-inch Color Touchscreen
- AM/FM Stereo Audio System
- Four-speaker Sound System
- Uconnect Voice Command with Bluetooth
- Connected Services Available
- Steering Wheel-mounted Audio Controls
- Wireless Apple CarPlay®<sup>13</sup> Support
- Wireless Android Auto™<sup>14</sup>
- Ram Connect<sup>15</sup> Trial

## UCONNECT 5C NAV WITH 10.1-INCH DISPLAY.

### UCONNECT 5C NAV AT A GLANCE:

- 10.1-inch Color Touchscreen
- AM/FM Stereo Audio System
- HD Radio
- Uconnect Voice Command with Bluetooth
- SiriusXM® with 360L<sup>16</sup>
- Steering Wheel-mounted Audio Controls
- Wireless Apple CarPlay<sup>13</sup> Support
- Wireless Android Auto<sup>14</sup>
- TomTom Based Navigation with Maps Over-The-Air (MOTA)
- Ram Connect<sup>15</sup> Trial



Head to the App Store and download the free Ram App. Use it to find out more information about specific Ram Connect<sup>15</sup> features and benefits.





159-inch wheelbase, extended with Crew Van Package



159-inch wheelbase with Crew Van Package



136-inch wheelbase with Crew Van Package

## FILL UP WITH CREW AND CARGO



### CREW VAN PACKAGE.

Room to take six to the jobsite is one thing; having enough room for passengers, their gear and materials is everything. Not only does the available Crew Van Package have comfortable, wide, three-seat bench seating, it also features the Mopar® Crew Van Kit, driver-side second-row fixed window and passenger-side sliding door with window. With the interior designed to accommodate underseat loading, longer items easily fit. Best yet, the durable fabrication is lightweight, which results in minimum sacrifice to the payload capacity.

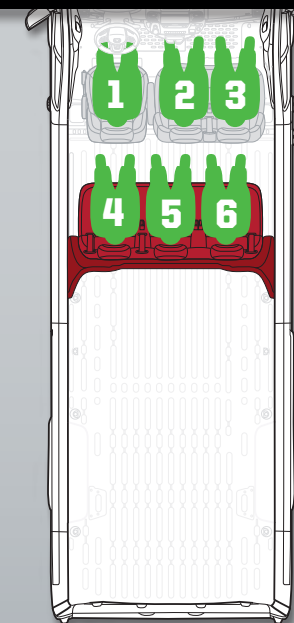

- Up to six-person seating capacity
- Welcoming cabin climate control
- Minimal cabin noise

- Secure protection from shifting cargo
- Capable volume and payload area
- Partition with window

# SEATING OPTIONS TO FIT YOUR NEEDS

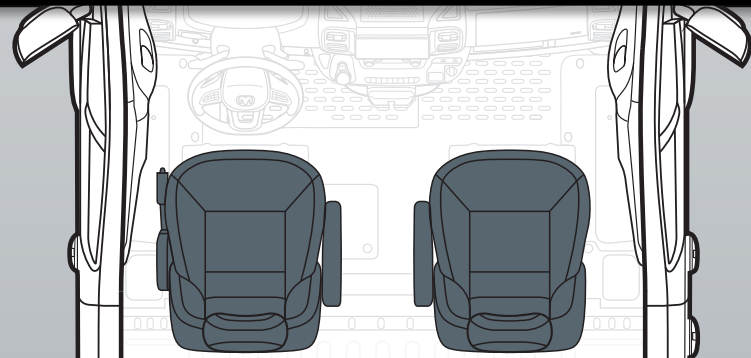

## BUCKET SEATS

- Standard four-way with spring suspension
- Available six-way adjustable seats with manual lumbar support and available heated seating surfaces
- Add the Crew Van Package for up to five-person seating →

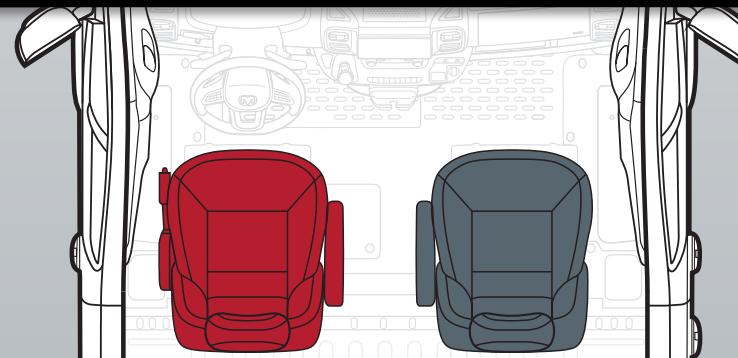
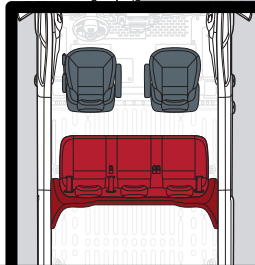

## DRIVER SUSPENSION BUCKET SEAT

- Available premium seat adds a pneumatic suspension and a weight-/size-conformity adjustment knob
- Add the Crew Van Package for up to five-person seating →

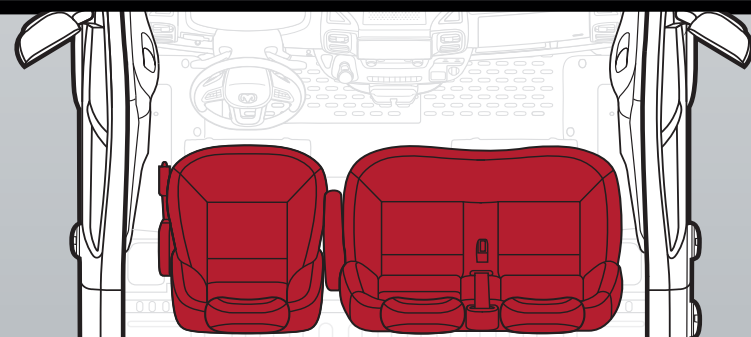
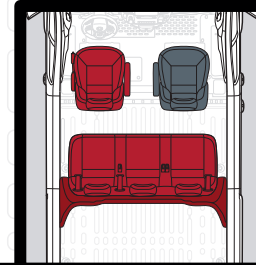

## THREE-OCCUPANT SEATING

- Single driver bucket seat joined by an available integrated two-person bench seat. The middle seatback insert folds down to become a convenient writing surface
- Add the Crew Van Package for up to six-person seating →

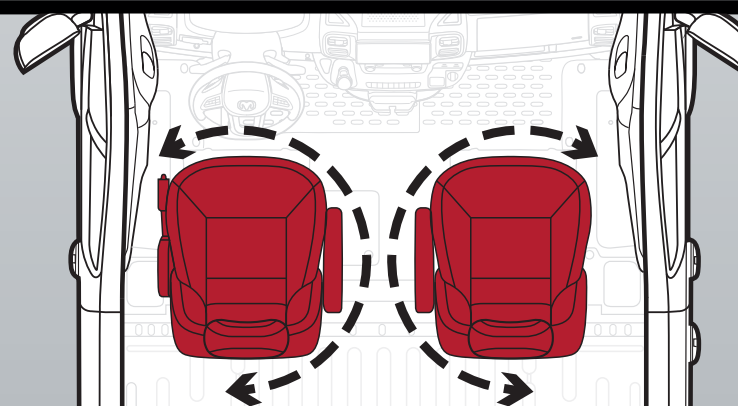
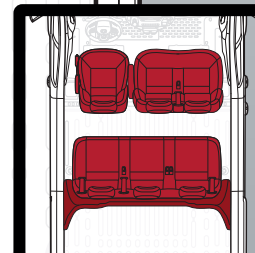

## SWIVEL SEATING

- Available swivel bucket seats with 180° inboard swivel range, 35° outboard swivel, a 58° recliner and a continuous height adjuster
- Add the Crew Van Package for up to five-person seating →

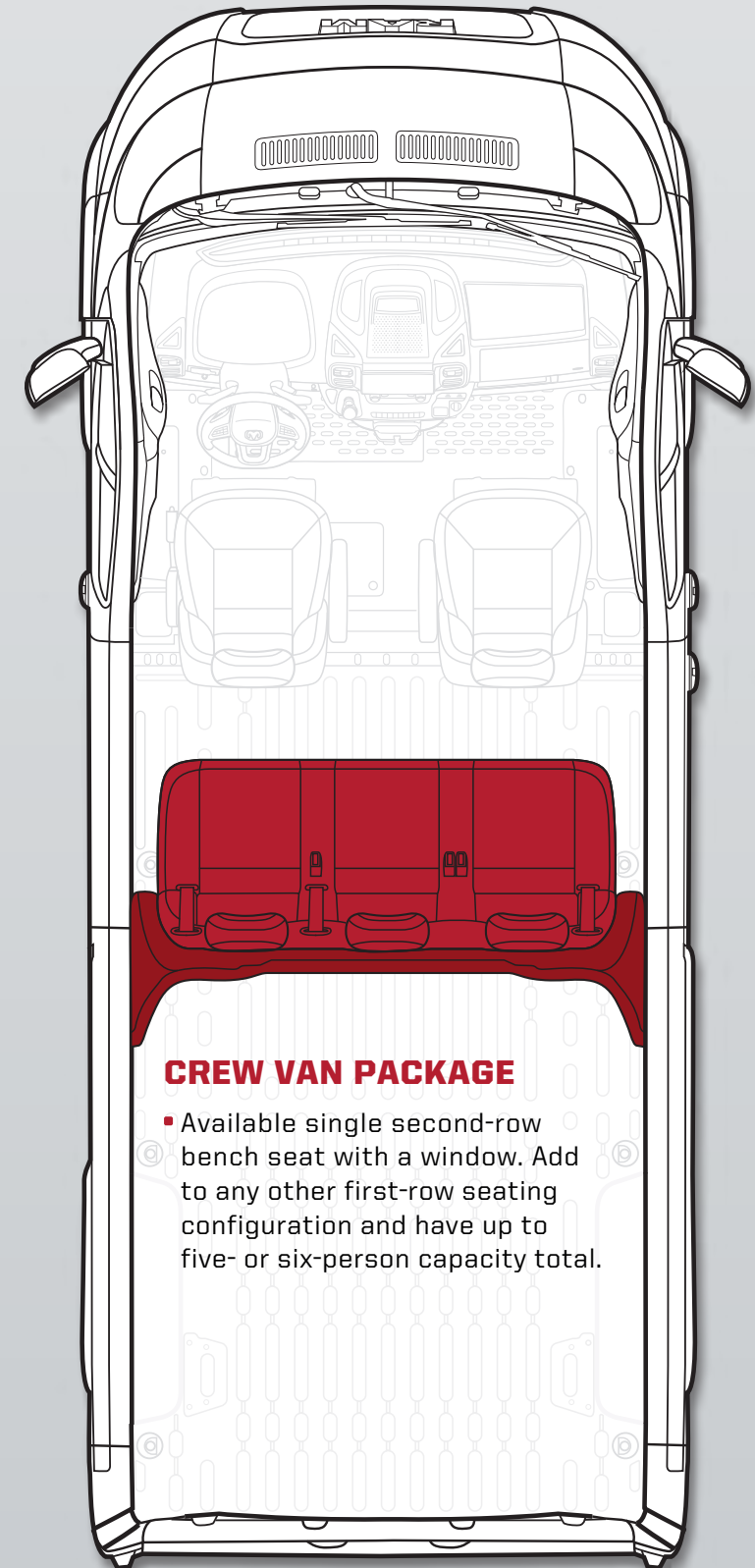
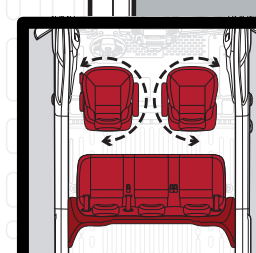

## CREW VAN PACKAGE

- Available single second-row bench seat with a window. Add to any other first-row seating configuration and have up to five- or six-person capacity total.

# CUSTOM FIT CAPACITY

# 6'4"

## MAXIMUM CARGO HEIGHT (ROOM TO WORK)

**SERIOUS CABIN VERSATILITY.** Without a doubt, this is an interior that was created to be adaptable, customizable and upfitted for business or trade. Regardless of which cargo-length van you choose, each one shares the same baseline of upfitability: nearly vertical side walls and best-in-class standard cargo height; max cargo width; width between the wheel wells and lowest load floor height. The available High Roof option shown here gives you even greater functionality.



- Available left-side Sliding Door with fixed glass
- Available lower-side Wall Panels
- Available Wood Floor
- Rear Doors with available fixed glass



- Available Cargo Partition with sliding window
- Available left-side Sliding Door with fixed glass
- Rear Doors with available fixed glass



- Available Cargo Partition
- Available upper- and lower-side Wall Panels
- Available Wood Floor



- Available Crew Van Package second-row seating with built-in Partition
- Up to six-person seating
- Isolated cargo area

Shown with aftermarket upfit.



# RAM PROMASTER® AUTHENTIC ACCESSORIES



**CARGO LOAD FLOOR<sup>17,18</sup>** On its own, our limited factory-warranted<sup>19</sup> Cargo Load Floor is ideal, using a modular design that fits all models and invites add-on kits. Features include an anti-slip surface, aluminum entry-point ramps, two integrated floor rails, four side rails (two per side) plus perfectly fitting hardware for all of it. Available only as an upfit when initially ordering your Ram ProMaster Cargo Van. Learn more at [mopar.com](http://mopar.com)

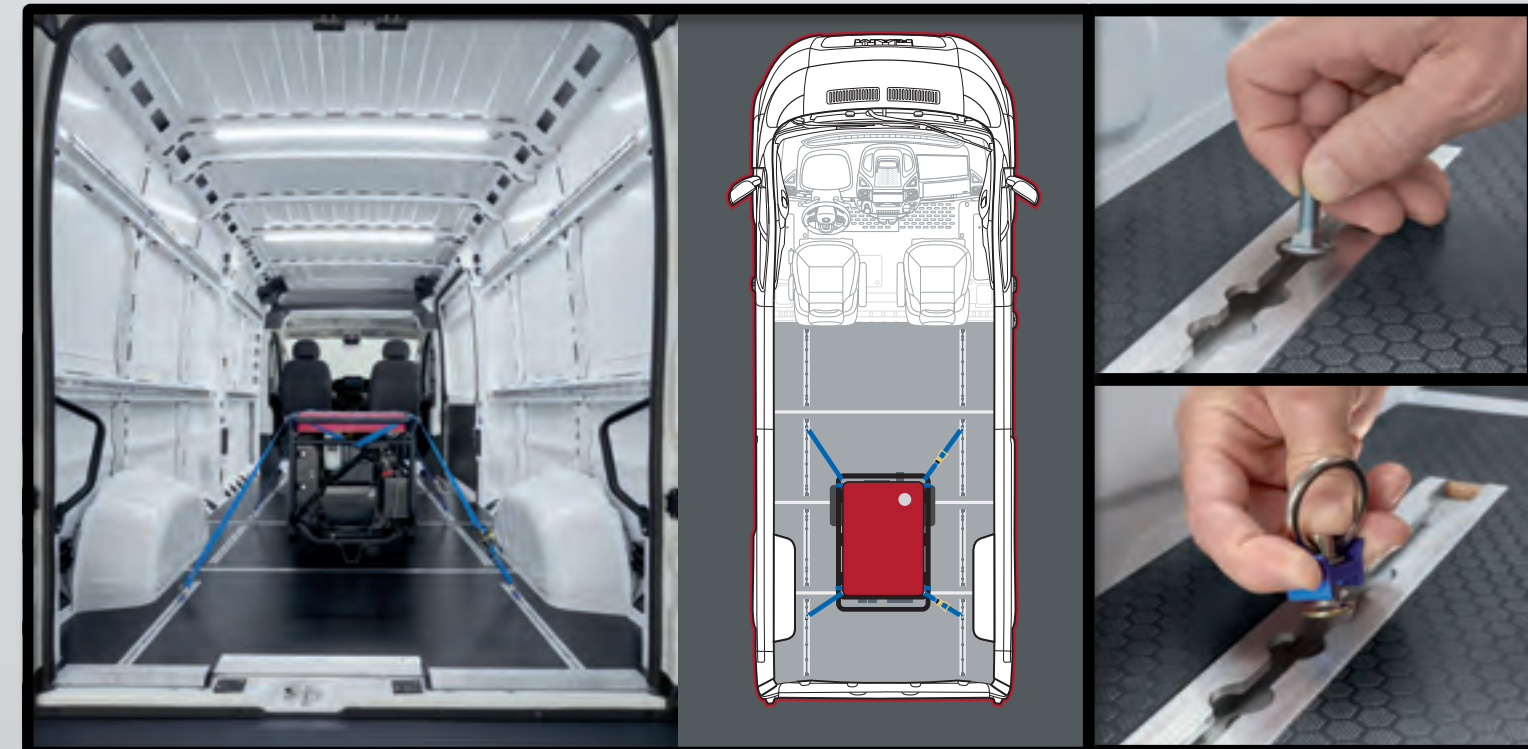

**CARGO TIE-DOWN TRACK SYSTEM.** This is multitasking at its best. The load floor system includes two in-floor tracks and two side tracks—one on each wall. Fitting all tracks are four 5/16-inch carriage bolts and four L-Channel Quick-Connect rings to securely strap down cargo (straps not included).





A. LED Cargo-Area Lights

B. Rear Assist Handles

C. Cargo Load Floor<sup>17,18</sup>

D. Hitch Receiver<sup>20</sup>

E. Molded Flat Splash Guards

F. Passenger Side Step<sup>21</sup>

G. Locking Gas Cap

H. Front and Rear Assist Handles

I. Rear Window Guards

J. Rear Step

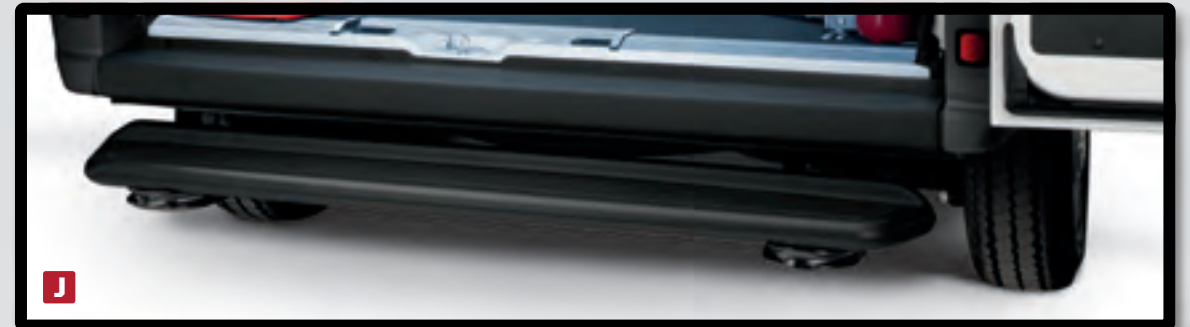
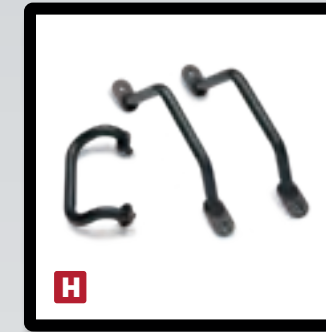
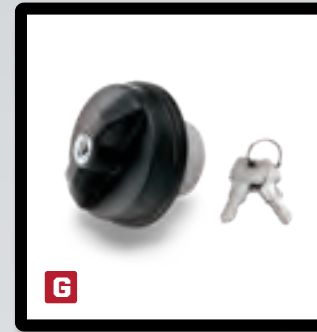

# RAM PROMASTER<sup>®</sup> AUTHENTIC ACCESSORIES



**THE RIGHT FIT. THE RIGHT PARTS. THE RIGHT PROTECTION.** When it comes to Ram ProMaster, not all parts and accessories are created equal. As the official service, parts and customer care provider for the Ram Brand, only Mopar<sup>®</sup> Parts and Accessories can ensure the proper fit, finish and functionality. That's because they're original equipment, engineered by the same people who designed your vehicle, which means you can personalize your ride with complete confidence.

Mopar is also more than parts and accessories. We're here to help you properly maintain and care for your vehicle. Our certified technicians are trained to know your vehicle best, and our Mopar Express Lane service departments are set up to get you in, out and back on the road. From parts and accessories to expert service and more, always be sure to choose Mopar.

Learn more at [mopar.com](https://www.mopar.com)

# POWER AND EFFICIENCY IN ACTION

NEW NEXT-GENERATION

## 3.6L PENTASTAR® V6

**276 HORSEPOWER** WITH  
250 LB-FT OF TORQUE

- Two-stage variable valve lift
- Variable Valve Timing
- Cooled Exhaust Gas Recirculation (EGR)
- High-tumble intake ports

### NEXT-GENERATION PENTASTAR ENGINE ENHANCEMENTS:

- Increased compression ratio: 11.3:1
- Lower internal friction
- Reduced weight

<b>HORSEPOWER</b>	276 hp
<b>TORQUE</b>	250 lb-ft
<b>CONFIGURATION</b>	60-degree V6
<b>DISPLACEMENT</b>	220 cu in (3,604 cc)
<b>BORE x STROKE</b>	3.78 x 3.27 in (96.0 x 83.0 mm)
<b>BLOCK MATERIAL</b>	Aluminum deep skirt design
<b>CYLINDER HEAD MATERIAL</b>	Aluminum alloy
<b>AIR INDUCTION</b>	Naturally aspirated
<b>VALVE TRAIN</b>	Chain-drive DOHC, 24-valve
<b>FUEL DELIVERY</b>	Sequential, multiport injection
<b>RECOMMENDED FUEL</b>	Unleaded regular (87 octane)
<b>COMPRESSION RATIO</b>	11.3:1
<b>ALTERNATOR</b>	180-amp (220-amp available)
<b>OIL CAPACITY</b>	6.0 quarts
<b>MAXIMUM RECOMMENDED OIL CHANGE INTERVAL</b>	10,000 miles



## NEW STANDARD 9-SPEED AUTOMATIC TRANSMISSION

- High efficiency in all gears and speeds, thanks to nested carriers, dog clutches and advanced hydraulic control unit architecture
- A wide ratio spread brings outstanding launch characteristics and smooth transfer between gears
- Short mid-range gears help to ensure quick transitions, and higher gears—7th, 8th and 9th transitions—relate to help lower engine rpm speeds



## **CLASS-EXCLUSIVE FRONT-WHEEL DRIVE (FWD).<sup>1</sup>**

Advantages to FWD are substantial. It enables outstanding control—especially valuable in snowy climates. It also utilizes the weight in the front end to help ensure great front tire “road grab.” By dispensing with the fore-to-aft drivetrain employed by our competitors, FWD also functions as a direct contributor to the best-in-class lowest load floor height.<sup>1</sup>

# **YEAR-ROUND CONFIDENCE**

**NEW ELECTRIC RACK AND PINION STEERING.** The new Electric Power Steering (EPS) contains its own Electronic Control Unit (ECU) to monitor vehicle speed, torque applied (using the Dynamic Steering Torque (DST) system) to the steering wheel, and other variables to determine the level of steering assist needed at any given moment. Increasing the power to the power steering motor helps to reduce the driver’s effort needed to turn the steering wheel lock to lock, which is especially helpful in tight parking or delivery situations. The convenient telescoping steering column is an unusual and welcome feature in the commercial world. We’ve made it standard on all models.

**ROBUST FRONT AND REAR SUSPENSION TECHNOLOGY.** In front, a MacPherson strut front suspension utilizes large, 62-mm twin-tube shock absorbers for solid support of the powertrain. This system is enhanced with GVW-tuned cast iron control arms for impressive durability, road manners and handling—even under heavy loads. Rear suspension technology is a beam axle/leaf spring design that’s light and simple yet robust.

**ANTILOCK BRAKING SYSTEM (ABS).** Our ABS controls and monitors each wheel independently. The high-performance brake system provides superb stopping power—notably, when trailering. Ram ProMaster® brakes even include electronic lining wear sensors that notify the driver (via an icon in the cluster) when pad replacement is imminent to help mitigate more expensive repairs.

**UNIBODY ENGINEERING.** A solid backbone is a designed-in advantage to the body-frame integral (unibody) engineering of your Ram ProMaster model, with each chassis mass-optimized and tuned for ideal performance. This integrated frame structure features boxed frame components, multiple crossrails and longitudinal rails—and all are crucially welded together. Depending on wheelbase length, you’ll find up to eight tough structural crossmembers, giving every Ram ProMaster model the ladder-frame integrity that ensures proper stiffness and long-term durability.

# BEST-IN-CLASS TURNING DIAMETER<sup>1</sup>



We view our cargo vans as your business partner. That's why we spent time crafting small details that yield a big convenience like only a 36.3-foot turning diameter (on 118-inch-wheelbase models). It's perfect for navigating crowded city streets, cramped loading docks or narrow back alleys.

**36.3-FT** TURNING DIAMETER

# CHASSIS CAB & CUTAWAY



**CUSTOMIZE YOURS  
TO BE THE IDEAL  
PARTNER**



Illustrated to show Cutaway.



Shown with aftermarket upfits.

**TOUGH UNIBODY STRENGTH AND CUSTOM BODY TREATMENT.** Combine industrial-grade capability with the right upfit, and your Ram ProMaster® Chassis Cab or Cutaway is ready for the job. The numbers speak for themselves: 3500 weight class only, built on a 136- or 159-inch wheelbase. Max length of 250.6 inches. Heavy-duty tuned suspension with a MacPherson strut front unit. Muscular 9,350-lb GVWR,<sup>22</sup> impressive 12,000-lb GCWR<sup>22</sup> and towing up to 5,600 lb,<sup>12</sup> with payload up to 5,250 lb.<sup>12</sup> Spec out your ideal model at [ram.com/promaster](https://ram.com/promaster)

# OUR STRENGTH, YOUR DETERMINATION



Shown with aftermarket upfit.

CHASSIS CAB & CUTAWAY PAYLOADS <small>(weight given in lb; must include weight of upfit)</small>	CHASSIS CAB			CUTAWAY		
	3500			3500		
	136" WB	159" WB	159" WB, EXTENDED	136" WB	159" WB	159" WB, EXTENDED
	82.4" CA	104.7" CA	104.7" CA	82.4" CA	104.7" CA	104.7" CA
<b>MAX PAYLOAD<sup>12</sup></b>	<b>5,170</b>	<b>5,130</b>	<b>5,120</b>	<b>5,250</b>	<b>5,220</b>	<b>5,170</b>

WB = wheelbase. CA = cab-to-axle.



Shown with aftermarket upfit.

# RAM PROMASTER® WINDOWED VAN

**PEOPLE COME FIRST.** Comfort, safety and security. You'll find these and more in our Windowed Van. Designed around the needs of people, it's available in 2500 and 3500 weight classes on the 159-inch wheelbase in your choice of two lengths. For optimum passenger comfort, the High Roof is standard. As with every Ram ProMaster, there is an abundance of upfit possibilities, plenty of cargo room and the solid power of the Pentastar® V6 engine.

If you require a Special Needs interior upfit, the flexibility of Windowed Van is your go-to solution. If additional power is needed, our available auxiliary switches can help handle the ancillary devices of ambulances, mobile medical clinics and DriveAbility Program applications.



**ONE WHEELBASE, EXPANSIVE OPTIONS.** Utilize the extended body on Windowed Van to create a significantly larger interior. The 14.4-inch extension adds nearly 43 cu ft of volume—the perfect solution when you need extra room for luggage or storage.



# RAM PROMASTER® BUYER'S GUIDE

## ENGINE/TRANSMISSION

**3.6L PENTASTAR® V6 WITH 9-SPEED AUTOMATIC**

ERF/DFH 22A 22A 22A 22A

## MECHANICAL FEATURES

**ADDITIONAL KEY FOBS** – Two

GXK 0 0 0 0

**ALTERNATOR** – 180-amp

BAD . . . .

– 220-amp (included with RV-Ready Prep Package)

BAJ O/P O/P . .

**AUXILIARY FUEL TAP**

XFZ . . . .

**BATTERY** – 95-amp

BCY . . . .

– 100-amp

BDC 0 0 0 0

– Auxiliary Power Connector

BCI . . . .

**CROSSWIND ASSIST**

BNU . . . .

**SPEED CONTROL** (included with Premium Convenience Group (AAM) and Premium RV Group (AA3); limited availability)

NHM O/P O/P O/P O/P

**ELECTRONIC STABILITY CONTROL®**

BNB . . . .

**ELECTRONIC PARK BRAKE**

XC4 . . . .

**ENGINE BLOCK HEATER**

NHK 0 0 0 0

**FUEL TANK** – 24-gallon

NFE . . . .

**FULL-SIZE SPARE TIRE**

TBB . . . .

**ELECTRIC POWER STEERING**

SBL . . . .

**PUSH-BUTTON START**

GX4 . . . .

**SPEED LIMITER** – 65-mph maximum speed

JJ4 0 0 0 0

– 70-mph maximum speed

JJ5 0 0 0 0

– 77-mph maximum speed

JJ9 0 0 0 0

**SUSPENSIONS** – Heavy-duty (2500/3500)

SDB . 0

– Light-duty (118-inch-wheelbase 1500 models only)

SDA .

– Medium-duty (136-inch-wheelbase 1500 models only)

SDJ .

– Premium heavy-duty (3500 models only; Cargo Van and Windowed Van require 159-inch wheelbase)

SDD 0 0 . .

– Touring

SDC .

**TEMPORARY SPARE TIRE MOUNT**

TBA . 0 0

**UPFITTER ELECTRONIC MODULE** – Vehicle System Interface Module

XXS 0 0 0 0

## EXTERIOR FEATURES

**RAM GRILLE IN SILVER WITH CHROME RAM BADGE**

ME6/MFD . . . .

**REAR WALL WINDOW**

GEV . . . .

**BLACK FRONT FASCIA**

MLF . . . .

**BLACK REAR BUMPER**

MBN . . . .

**CHROME GRILLE** (included with Premium Appearance Group and RV-Ready Prep Package; requires fog lamps)

MFE O/P O/P O/P O/P

**DAYTIME RUNNING LAMPS** (included with Safety Group)

LMK O/P O/P 0 0

**DOORS, REAR** – 260-degree-opening

GLF . . . .

– Rear hinged doors with fixed glass (includes deep-tint sunscreen glass)

GLB 0 .

**DOORS, SIDE** – Left side with fixed-glass window and grate (includes deep-tint sunscreen glass; 136-inch-wheelbase models with Standard Roof only)

GKD 0

– Left side with no glass

GKE 0

(not available on 118-inch-wheelbase models or Crew Van Package)

– Left side with fixed window

GKT 0

(includes deep-tint sunscreen glass; not available on 118-inch-wheelbase models, 136-inch-wheelbase models with Standard Roof or Crew Van Package)

. = Standard 0 = Optional P = Available within Package

## EXTERIOR FEATURES (continued)

**DOORS, SIDE (continued)**– Right side with no glass

GKA . . . .

– Right side with fixed glass (Standard Roof models only on Cargo Van; includes window grate and deep-tint sunscreen glass)

GKB 0

– Right side with fixed window (High Roof models only; includes deep-tint sunscreen glass; included with Crew Van Package)

GKS O/P . . . .

**TAILLAMP EXTENSION WIRING**

XGF . . . .

**FRONT FOG LAMPS WITH CORNERING FUNCTION**

(included with Convenience Group, Driver Convenience Group, Advanced Safety Group, RV-Ready Prep Package, Safety Group and Premium Appearance Group)

LNJ O/P O/P O/P O/P

**FRONT LICENSE PLATE BRACKET**

MDA 0 0 0 0

**HALOGEN HEADLAMPS**

LMA . . . .

– Automatic (included with Premium RV Group (ADL/AA3) and Premium Convenience Group (AAM/ADK))

LMG P P P P

– Auto High-Beam Headlamp Control (included with Premium RV Group (ADL/AA3) and Premium Convenience Group (AAM/ADK))

LMS P P P P

**CLASS IV HITCH RECEIVER** (included with RV-Ready Prep Package)

XFH O/P O/P

**MIRRORS** – Manual-adjustable/manual-folding

GTP . . . .

– Power-adjustable/power-folding, heated

GTR O/P O/P

(included with Driver Convenience Group and Safety Group)

– Wide power-adjustable, heated

GTB 0 0 0 0

**RAIN-SENSITIVE WINDSHIELD WIPERS**

(included with Premium RV Group and Premium Convenience Group)

JHC P P P P

**ROOF CLEARANCE LAMPS** – Deletes the front clearance lamps

LT8 . . . .

– Front

LNC . . . .

– Rear

LNG . . . .

**SPLASH GUARDS** – Vehicle Set (by Mopar®)

MKN 0 0

**STEP** – Rear Bumper Extension

(not available with Class IV hitch receiver; see your dealer for availability; by Mopar)

MDM 0 0

– Sliding Door Step, Left Side (not available on 118-inch-wheelbase models; requires driver-side door; see your dealer for availability, restrictions apply; by Mopar)

MR3 0 0

– Sliding Door Step, Right Side (not available on 118-inch-wheelbase models; see your dealer for availability; by Mopar)

MRZ 0 0

**WHEELS** – 16-inch aluminum (included with RV-Ready Prep Package)

WDN O/P O/P 0 0

– 16-inch Silver-painted steel with center cap

WCS . . . .

– 16-inch Silver-painted steel with full wheel cover

W6A 0 0 0 0

– 16-inch Black-painted steel

WDL 0 0 0 0

– Center Cap Delete

WH8 0 0 0 0

**WINDOW** – Left side, second-row fixed with deep-tint sunscreen glass

(optional on High Roof Cargo Van only; included with Crew Van Package)

GEA O/P . . . .

**WINDOW DEFROSTER** – Rear (requires rear doors with glass on Cargo Van models)

GFA 0 . . . .

. = Standard 0 = Optional P = Available within Package

For more information, visit [ram.com/promaster](http://ram.com/promaster)

# RAM PROMASTER® BUYER'S GUIDE

## INTERIOR FEATURES

	SALES CODE	Cargo Van	Windowed Van	Chassis Cab	Cutaway
<b>AUXILIARY POWER OUTLET</b> – 12-volt, front	JJJ	•	•	•	•
– Rear	JKP	0	0		
– 115-volt	JKV	0	0	0	0
<b>AIR CONDITIONING</b> – Air Conditioning Delete; heater only	HCD	0	0	0	0
– Manually controlled, with heat	HAA	•	•	•	•
– Rear Heater Air Conditioning Prep Package (not available with Air Conditioning Delete; included with RV-Ready Prep Package)	HDG	0/P	0/P	0	0
<b>ASSIST HANDLE</b> – Rear Doors (by Mopar®)	CSR	0	0		
<b>AUXILIARY UPFITTER SWITCHES</b> – Two (included with RV-Ready Prep Package)	LHL	0/P	0/P	0	0
<b>REAR CARGO LED LAMP</b> (packaged with Interior LED Lighting Group; not available with Crew Van Package)	LDB	0/P	0/P		
– Ambient LED Interior Lighting (packaged with Interior LED Lighting Group, RV-Ready Prep Package and Convenience Group)	LHA	P	P	0/P	0/P
<b>CARGO COMPARTMENT FLOOR MAT</b> (by Mopar)	CKL	0			
<b>CARGO AREA LIGHTING</b> – Incandescent	LPE	•	•		
<b>CARGO PARTITION</b> – None	CTP	•	•		
– With sliding window (not available with Crew Van Package)	XJI	0			
– Without window (includes Rearview Mirror Delete; not available with Crew Van Package)	CWC	0			
<b>CARGO TIE-DOWNS</b> – Floor		•			
– Side wall	CKT	•			
<b>CLUSTER</b> – 3.5-inch Thin Film Transistor Black-and-White Driver Information Display	JAE	•	•	•	•
– 7-inch Thin Film Transistor color Driver Information Display (included with Premium RV Group, Advanced Safety Group and Premium Convenience Group)	JAL	P	P	P	P
<b>FLOOR MATS</b> – Premium Carpet (not available with passenger double seat; by Mopar)	CCL	0	0		
– All-Weather (not available with passenger double seat; by Mopar)	CCK	0	0		
<b>INSTRUMENT PANEL WITH BRIGHT BEZELS</b>	JBD	0	0	0	0
<b>LOCKING GLOVE BOX</b> (included with Convenience Group and RV-Ready Prep Package)	JKA	P	P	P	P
<b>POWER DOOR LOCKS</b> – Speed-sensitive	JPH	•	•	•	•
<b>REAR DOOR CARGO NET</b> (included with Convenience Group and RV-Ready Prep Package)	CKR	P	P		
<b>SEATING SURFACES</b> – Cloth	*A7	•	•	•	•
– Vinyl (not available with Premium RV Group)	*B7	0	0	0	0
– Leather-trimmed bucket (includes driver and passenger swivel seats with six-way adjustments; included with Premium RV Group)	*AL	0/P	0/P		0/P
<b>SEATS</b> – Four-way manually adjustable driver- and front-passenger bucket	JVA/JWA	•	•	•	•
– Driver six-way adjustable with two-way manual lumbar adjust (included with RV-Ready Prep Package and leather-trimmed bucket seats)	JVB	0/P	0/P	0/P	0/P
– Driver and passenger six-way adjustable with two-way manual lumbar adjust (included with RV-Ready Prep Package and leather-trimmed bucket seats)	JWB	0/P	0/P	0/P	0/P
– Driver suspension (not available with driver swivel seat and leather-trimmed bucket seats; optional with driver six-way adjustable with two-way manual lumbar adjust seat)	CXX	0	0	0	0
– Driver swivel (not available with vinyl bucket seats or cargo partition; included with Premium RV Group, RV-Ready Prep Package and leather-trimmed bucket seats; optional with driver six-way adjustable with two-way manual lumbar adjust seat)	CEA	0/P	0/P	0/P	0/P

• = Standard 0 = Optional P = Available within Package

## INTERIOR FEATURES (continued)

	SALES CODE	Cargo Van	Windowed Van	Chassis Cab	Cutaway
<b>SEATS (continued)</b> – Heated driver (optional with driver six-way adjustable with two-way manual lumbar adjust seat; not available with driver swivel seat, driver suspension seat or leather-trimmed bucket seats)	CMB	0	0	0	0
– Heated passenger (requires heated driver seat; not available with passenger swivel seat; optional with passenger six-way adjustable with two-way lumbar adjust seats)	CMC	0	0	0	0
– Passenger double (not available with RV-Ready Prep Package, driver swivel seat or passenger six-way adjustable with two-way lumbar adjust seats)	CAA	0		0	
– Passenger Seat Delete (includes deactivation of the passenger air bag <sup>10</sup> and deletion of the passenger seat belt mount; not available with RV-Ready Prep Package, passenger double seat or passenger six-way adjustable with two-way lumbar adjust seats)	CD9	0	0	0	0
– Passenger swivel (not available with vinyl bucket seats or cargo partition; included with Premium RV Group, RV-Ready Prep Package and leather-trimmed bucket seats; optional on passenger six-way adjustable with two-way manual lumbar adjust seats; requires driver swivel seat)	CHR	0/P	0/P	0/P	0/P
<b>SHELF ABOVE ROOF TRIM</b> (included with Convenience Group and RV-Ready Prep Package)	CTA	P	P	P	P
<b>SPRAY-ON FLOOR LINER</b> (by Mopar)	XMF	0	0		
<b>STEERING COLUMN</b> – Telescoping	SUC	•	•	•	•
<b>STEERING WHEEL</b> – Leather-wrapped (included with Premium RV Group and Advanced Safety Group)	SCC	0/P	0/P	0/P	0/P
<b>TIRE PRESSURE MONITORING LIGHT</b>	XGM	•	•	•	•
<b>UPFIT INTERFACE CONNECTORS</b> (included with Rear-Speaker Wiring Prep)	BC3	•	•	•	•
<b>WALL PANELS</b> – Upper- and lower-side (not available with Crew Van Package)	CTE	0			
– Lower-side (included with side-wall paneling upper and lower; not available with Crew Van Package)	CMG	0/P	0		
<b>WINDOWS</b> – Power with one-touch down feature	JPY	•	•	•	•
– Window Guards, Rear (not available on 118-inch-wheelbase or 136-inch-wheelbase Standard Roof Cargo Vans or 136-inch-wheelbase 2500 Windowed Van; by Mopar)	XGC	0	0		
<b>WIRELESS CHARGING PAD</b> (included with Premium RV Group and Premium Convenience Group)	RFX	P	P	P	P
<b>WOOD FLOOR</b> – Rear (not available with Spray-On Floor Liner or Crew Van Package)	CME	0	0		
<b>UCONNECT® MULTIMEDIA</b>					
<b>REAR-SPEAKER WIRING PREP</b> (includes upfit interface connectors)	RED	•	•	•	•
<b>UCONNECT 5C WITH 7-INCH DISPLAY</b> – Includes Android Auto, <sup>TM14</sup> Apple CarPlay <sup>®13</sup> support, Bluetooth <sup>®</sup> hands-free phone <sup>23</sup> and audio, integrated center stack radio and SiriusXM <sup>®</sup> Radio <sup>16</sup>	UBC	•	•	•	•
<b>UCONNECT 5C NAV WITH 10.1-INCH DISPLAY</b> – Includes Navigation, HD Radio, Android Auto, <sup>14</sup> Apple CarPlay <sup>13</sup> support, Integrated Voice Command with Bluetooth, integrated center stack and SiriusXM with 360L <sup>16</sup> (included with Premium RV Group and Premium Convenience Group)	UBN	P	P	P	P
<b>GLOBAL TELEMATICS BOX MODULE (TBM)</b>	RDG	•	•	•	•

• = Standard 0 = Optional P = Available within Package

For more information, visit [ram.com/promaster](http://ram.com/promaster)

# RAM PROMASTER® BUYER'S GUIDE

## SAFETY & SECURITY

	SALES CODE	Cargo Van	Windowed Van	Chassis Cab	Cutaway
<b>ADAPTIVE CRUISE CONTROL WITH STOP AND GO<sup>9</sup></b> (included with Premium RV Group (ADL), Advanced Safety Group, Premium Convenience Group (ADK) and Active Driving Assist System; restrictions apply; late availability)	NHZ	O/P	O/P	O/P	O/P
<b>AIR BAGS<sup>10</sup></b> – Driver and front-passenger	CGW	•	•	•	•
– Supplemental side-curtain front	CJ4	•	•	•	•
– Supplemental front-seat side	CJ1	•	•	•	•
<b>DROWSY-DRIVER DETECTION<sup>9</sup></b>	XNM	•	•	•	•
<b>DOT-CERTIFIED ROADSIDE SAFETY KIT</b> (by Mopar®)	ACL	0	0	0	0
<b>BLIND SPOT MONITORING<sup>4</sup> WITH REAR CROSS-PATH DETECTION<sup>5</sup></b> (included with Advanced Safety Group, Lane Management Group and Safety Group; requires power-heated mirrors or power-folding/heated mirrors)	XAN	O/P	O/P		
<b>REARVIEW AUTO-DIMMING DIGITAL DISPLAY MIRROR</b> (included with Safety Group)	GRG	O/P	O/P	0	0
<b>LANESENSE® LANE DEPARTURE WARNING PLUS<sup>11</sup></b> (included with Advanced Safety Group (ALP) and Lane Management Group)	LAS	P	P	P	P
<b>FULL-SPEED FORWARD COLLISION WARNING PLUS WITH PEDESTRIAN/CYCLIST EMERGENCY BRAKING<sup>3</sup></b>	LSU	•	•	•	•
<b>INTELLIGENT SPEED ASSIST</b> (included with Advanced Safety Group)	NH4	P	P	P	P
<b>PARKVIEW® REAR BACK-UP CAMERA<sup>5</sup> WITH DYNAMIC GRID LINES</b> (not available with 360° Surround-View Camera System <sup>5</sup> )	XAC	•	•		
<b>PARKVIEW REAR BACK-UP CAMERA<sup>5</sup> KIT</b>	XA3			•	•
<b>PARKSENSE® FRONT/REAR PARK ASSIST<sup>7</sup></b> (included with Driver Convenience Group; requires front fog lamps)	XAG	O/P	O/P		
<b>PARKSENSE REAR PARK ASSIST<sup>7</sup></b> (included with Safety Group)	XAA	O/P	O/P		
<b>REMOTE KEYLESS ENTRY</b>	GXM	•	•	•	•
<b>MULTI-COLLISION BRAKING</b>	BNA	•	•	•	•
<b>REMOTE PROXIMITY KEYLESS ENTRY</b> (included with Premium RV Group and Premium Convenience Group; requires ParkSense Rear Park Assist <sup>7</sup> or ParkSense Front/Rear Park Assist <sup>7</sup> on Cargo Van or Windowed Van)	GXD	P	P	P	P
<b>REMOTE START SYSTEM<sup>24</sup></b> (included with Driver Convenience Group)	XBM	O/P	O/P	0	0
<b>SECURITY ALARM<sup>25</sup></b>	LSA	0	0	0	0
<b>360° SURROUND-VIEW CAMERA SYSTEM<sup>5</sup></b> (included with Driver Convenience Group and Advanced Safety Group (ALP); requires wide power-heated mirrors or power-folding/heated mirrors)	XAK	P	P		
<b>TRAFFIC SIGN RECOGNITION<sup>3</sup></b> – Traffic Sign Information (included with Premium RV Group and Premium Convenience Group)	SJB	•	•	•	•
	SJF	P	P	P	P

• = Standard 0 = Optional P = Available within Package

For more information, visit [ram.com/promaster](https://ram.com/promaster)

## PACKAGES/GROUPS

	SALES CODE	Cargo Van	Windowed Van	Chassis Cab	Cutaway
<b>ADVANCED SAFETY GROUP</b> – Includes 7-inch Thin Film Transistor color cluster, front fog lamps with cornering, Adaptive Cruise Control with Stop and Go <sup>9</sup> , Intelligent Speed Assist, LaneSense Lane Departure Warning Plus <sup>11</sup> , Active Driver Assist System, leather-wrapped steering wheel, Blind Spot Monitoring <sup>4</sup> with Rear Cross-Path Detection <sup>5</sup> on Cargo Van and Windowed Van, and 360° Surround-View Camera System <sup>5</sup> on Cargo Van and Windowed Van (requires wide heated mirrors or power-folding/heated mirrors; restrictions apply)	ALP	0	0	0	0
<b>AMBIENT LED INTERIOR LIGHTING</b> (packaged with LED Lighting Group, RV-Ready Prep Package and Convenience Group)	LHA	P	P	O/P	O/P
<b>CREW VAN PACKAGE</b> – Includes Mopar Crew Van Kit, driver-side second-row fixed window, Inside Rearview Mirror Delete, passenger sliding door with window and second-row bench seat (provides seating for up to five including driver; up to six passengers with front-passenger double seat; restrictions apply; requires High Roof)	AAF	0			
<b>DELIVERY PACKAGE 1</b> – Includes radio mute on Reverse (requires speed limiter with 65-mph, 70-mph or 77-mph maximum speed)	AZA	0	0	0	0
<b>DELIVERY PACKAGE 2</b> – Includes radio mute on Reverse, engine auto shutoff and driver feedback system (requires speed limiter with 65-mph, 70-mph or 77-mph maximum speed)	AZB	0	0	0	0
<b>DRIVER CONVENIENCE GROUP</b> – Includes Remote Start System <sup>24</sup> , power-folding/heated mirrors, front fog lamps with cornering, ParkSense Front/Rear Park Assist <sup>7</sup> and 360° Surround-View Camera System <sup>5</sup>	AAC	0	0		
<b>LANE MANAGEMENT GROUP</b> – Includes LaneSense Lane Departure Warning Plus <sup>11</sup> and Blind Spot Monitoring <sup>4</sup> with Rear Cross-Path Detection <sup>5</sup> (requires wide power-heated mirrors or power-folding/heated mirrors; not available with Advanced Safety Group)	AWC	0	0	0	0
<b>INTERIOR LED LIGHTING GROUP</b> – Includes rear cargo LED lamp and Ambient LED Interior Lighting (not available with Convenience Group or RV-Ready Prep Package)	AD6	0	0		
<b>CONVENIENCE GROUP</b> – Includes locking glove box, front fog lamps with cornering, Ambient LED Interior Lighting, shelf above roof trim, underseat storage tray and rear-door cargo net on Cargo Van and Windowed Van models (not available with RV-Ready Prep Package)	AJK	0	0	0	0
<b>PREMIUM APPEARANCE GROUP</b> – Includes chrome grille and fog lamps with cornering (not available with Convenience Group or RV-Ready Prep Package)	ALU	0	0	0	0
<b>PREMIUM CONVENIENCE GROUP</b> – Includes remote proximity keyless entry, wireless charging pad, rain-sensitive windshield wipers, 7-inch Thin Film Transistor color cluster, automatic headlamps, Auto High-Beam Headlamp Control, Adaptive Cruise Control with Stop and Go <sup>9</sup> on (ADK), speed control on (AAM), Uconnect® 5C NAV with 10.1-inch display and Traffic Sign Information (requires ParkSense Front/Rear Park Assist <sup>7</sup> or ParkSense Rear Park Assist <sup>7</sup> ; restrictions apply)	AAM/ADK	0	0	0	0
<b>RV-READY PREP PACKAGE</b> – Includes 220-amp alternator, driver swivel seat, passenger swivel seat, cargo net, shelf above roof trim, driver and passenger six-way adjustable with two-way manual lumbar adjust seats, Class IV hitch receiver, Rear Heater Air Conditioning Prep Package, locking glove box, auxiliary switches, front fog lamps with cornering, Ambient LED Interior Lighting, chrome grille and 16-inch aluminum wheels (not available on 118-inch wheelbase)	ACV	0	0		
<b>PREMIUM RV GROUP</b> – Includes leather-trimmed buck seats, remote proximity keyless entry, wireless charging pad, rain-sensitive windshield wipers, 7-inch Thin Film Transistor color cluster, automatic headlamps, Auto High-Beam Headlamp Control, Adaptive Cruise Control with Stop and Go <sup>9</sup> on (ADL), speed control on (AA3), Uconnect 5C NAV with 10.1-inch display, Traffic Sign Information and leather-wrapped steering wheel (requires ParkSense Front/Rear Park Assist <sup>7</sup> or ParkSense Rear Park Assist <sup>7</sup> ; restrictions apply)	AA3/ADL	0	0		0
<b>SAFETY GROUP</b> – Includes Digital Rearview Mirror with auto-dimming, power-folding/heated mirrors, front fog lamps with cornering, daytime running headlamps, ParkSense Rear Park Assist <sup>7</sup> and Blind Spot Monitoring <sup>4</sup> with Rear Cross-Path Detection <sup>5</sup>	AJ1	0	0		

• = Standard 0 = Optional P = Available within Package

**RAM PROMASTER® EXTERIOR COLORS**



Bright White

**INTERIOR FABRICS**

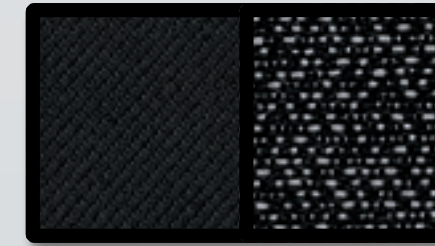

Black Cloth  
(standard)

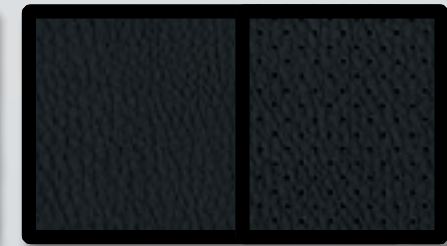

Black Bristol Leather  
(available)

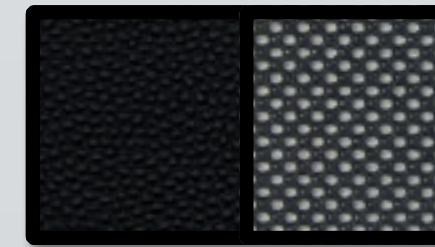

Black Vinyl  
(available)

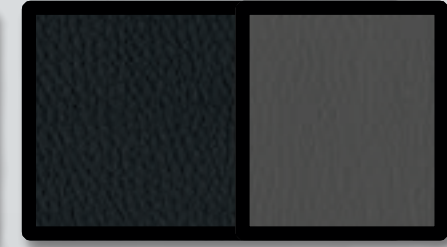

Black / Diesel Gray Bristol Leather  
(available)



Sandstone Pearl



Bright Silver  
Metallic



Granite Crystal  
Metallic



Black



Patriot Blue  
Pearl Coat

**WHEELS**



16-inch Painted Steel Wheel  
with Center Cap  
(standard)



16-inch Black-Painted Steel Wheel  
with Center Cap  
(available)



School Bus Yellow



Broom Yellow



Flame Red



Deep Cherry Red  
Crystal Pearl



16-inch Painted Steel Wheel  
with Wheel Cover  
(available)



16-inch Aluminum Wheel  
(available)

**RAM PROMASTER® SPECIFICATIONS – CARGO VAN & WINDOWED VAN**

CAPABILITY	CARGO VAN										WINDOWED VAN	
	1500			2500			3500				2500	3500
	118" WB	136" WB		136" WB		159" WB	136" WB		159" WB	159" WB, EXTENDED	159" WB	159" WB, EXTENDED
	STANDARD ROOF	STANDARD ROOF	HIGH ROOF	STANDARD ROOF	HIGH ROOF	HIGH ROOF	STANDARD ROOF	HIGH ROOF	HIGH ROOF	HIGH ROOF	HIGH ROOF	HIGH ROOF
<b>GVWR<sup>22</sup></b> (lb)	8,550	8,550	8,550	8,900	8,900	8,900	9,350	9,350	9,350	9,350	8,900	9,350
<b>GCWR<sup>22</sup></b> (lb)	12,000	12,000	12,000	12,000	12,000	12,000	12,000	12,000	12,000	12,000	12,000	12,000
<b>BASE CURB WEIGHT</b> (lb)	4,538	4,636	4,747	4,643	4,746	4,900	4,672	4,795	4,921	4,919	4,953	5,076
<b>MAXIMUM PAYLOAD<sup>12</sup></b> (lb)	4,010	3,910	3,800	4,260	4,150	4,000	4,680	4,560	4,430	4,430	3,950	4,270
<b>FRONT GAWR<sup>22</sup></b> (lb)	4,629	4,629	4,629	4,629	4,629	4,629	4,629	4,629	4,629	4,629	4,629	4,629
<b>REAR GAWR<sup>22</sup></b> (lb)	5,004	5,291	5,291	5,291	5,291	5,291	5,291	5,291	5,291	5,291	5,291	5,291
<b>CURB-TO-CURB TURNING</b> (ft)	36.3	40.7	40.7	40.7	40.7	46.8	40.7	40.7	46.8	46.8	46.8	46.8
<b>MAXIMUM TOWING<sup>12</sup></b> (lb) SAE J2807 Compliant	6,910	6,800	6,700	6,800	6,700	6,480	6,700	6,600	6,480	6,410	6,480	6,410

**DIMENSIONS**

<b>BODY HEIGHT</b> (in)	91.7	93.0	103.6	93.0	103.6	102.1	93.0	103.6	102.1	102.5	102.1	102.5
<b>OVERALL BODY LENGTH</b> (in)	195.4	213.2	213.2	213.2	213.2	236.2	213.2	213.2	236.2	250.6	236.2	250.6
<b>VEHICLE WIDTH WITHOUT MIRRORS</b> (in)	81.3	81.3	81.3	81.3	81.3	81.3	81.3	81.3	81.3	81.3	81.3	81.3
<b>VEHICLE WIDTH WITH MIRRORS EXTENDED</b> (in)	112.2	112.2	112.2	112.2	112.2	112.2	112.2	112.2	112.2	112.2	112.2	112.2
<b>CARGO BODY LENGTH AT FLOOR</b> (in)	103.1	120.6	120.6	120.6	120.6	147.0	120.6	120.6	147.0	161.3	147.0	161.3
<b>CARGO WIDTH AT FLOOR</b> (in)	75.6	75.6	75.6	75.6	75.6	75.6	75.6	75.6	75.6	75.6	75.6	75.6
<b>CARGO WIDTH AT WHEEL WELL</b> (in)	56.0	56.0	56.0	56.0	56.0	56.0	56.0	56.0	56.0	56.0	56.0	56.0
<b>SIDE-DOOR OPENING WIDTH</b> (in)	42.3	49.2	49.2	49.2	49.2	49.2	49.2	49.2	49.2	49.2	49.2	49.2
<b>SIDE-DOOR OPENING HEIGHT</b> (in)	58.5	58.5	69.1	58.5	69.1	69.1	58.5	69.1	69.1	69.1	69.1	69.1
<b>REAR DOORS OPENING WIDTH</b> (in)	63.4	63.4	63.4	63.4	63.4	63.4	63.4	63.4	63.4	63.4	63.4	63.4
<b>REAR DOORS OPENING HEIGHT</b> (in)	59.8	59.8	70.5	59.8	70.5	70.5	59.8	70.5	70.5	70.5	70.5	70.5
<b>MAXIMUM CARGO HEIGHT</b> (in)	66.9	66.9	77.1	66.9	77.1	77.1	66.9	77.1	77.1	77.1	77.1	77.1
<b>MAXIMUM CARGO VOLUME<sup>12</sup></b> (cu ft)	259.2	303.7	352.9	303.7	352.9	420.2	303.7	352.9	420.2	462.9	420.2	462.9

WB = wheelbase.

**RAM PROMASTER® SPECIFICATIONS – CHASSIS CAB & CUTAWAY**

CAPABILITY	CHASSIS CAB			CUTAWAY		
	3500			3500		
	136" WB	159" WB	159" WB, EXTENDED	136" WB	159" WB	159" WB, EXTENDED
	82.4" CA	104.7" CA	104.7" CA	82.4" CA	104.7" CA	104.7" CA
<b>GVWR<sup>22</sup></b> (lb)	9,350	9,350	9,350	9,350	9,350	9,350
<b>GCWR<sup>22</sup></b> (lb)	12,000	12,000	12,000	12,000	12,000	12,000
<b>BASE CURB WEIGHT</b> (lb)	4,178	4,218	4,232	4,103	4,134	4,182
<b>MAXIMUM PAYLOAD<sup>12</sup></b> (lb)	5,170	5,130	5,120	5,250	5,220	5,170
<b>FRONT GAWR<sup>22</sup></b> (lb)	4,629	4,629	4,629	4,629	4,629	4,629
<b>REAR GAWR<sup>22</sup></b> (lb)	5,291	5,291	5,291	5,291	5,291	5,291
<b>CURB-TO-CURB TURNING</b> (ft)	36.3	40.7	46.8	36.3	40.7	46.8
<b>MAXIMUM TOWING<sup>12</sup></b> (lb)	5,600	5,600	5,600	5,600	5,600	5,600



**DIMENSIONS**

<b>BODY HEIGHT</b> (in)	87.7	87.3	87.3	87.7	87.3	87.3
<b>OVERALL BODY LENGTH</b> (in)	213.2	236.2	250.6	213.2	236.2	250.6
<b>VEHICLE WIDTH WITHOUT MIRRORS</b> (in)	81.3	81.3	81.3	81.3	81.3	81.3
<b>VEHICLE WIDTH WITH MIRRORS EXTENDED</b> (in)	112.2	112.2	112.2	112.2	112.2	112.2
<b>CAB TO REAR AXLE<sup>26</sup></b> (in)	82.4	104.7	104.7	82.4	104.7	104.7
<b>OVERHANG REAR AXLE TO END OF FRAME<sup>27</sup></b> (in)	39.6	39.6	39.6	39.6	39.6	39.6

WB = wheelbase. CA = cab-to-axle.

For more information, visit [ram.com/promaster](https://ram.com/promaster)

# RAM PROMASTER® CONFIGURATIONS

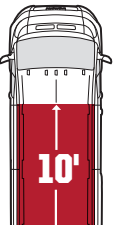
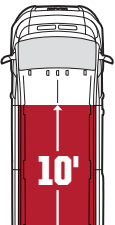
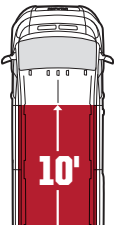
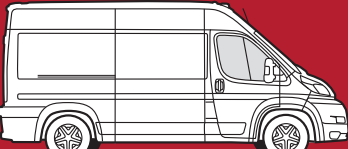
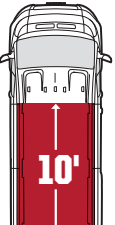
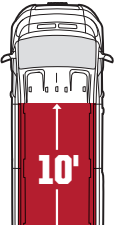
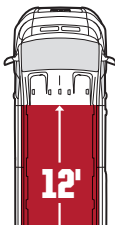
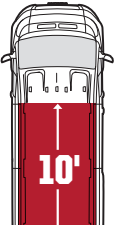
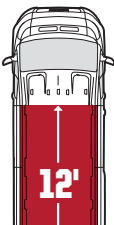
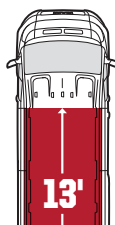
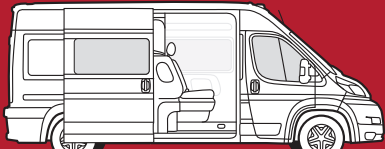
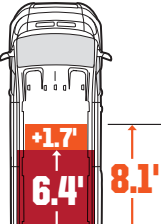
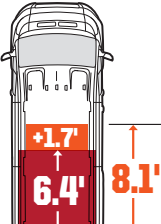
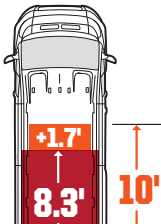
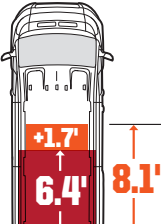
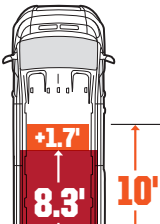
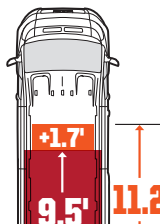
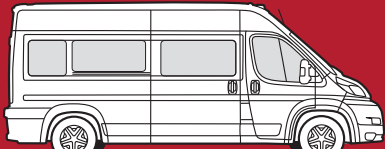
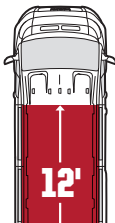
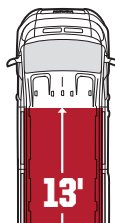
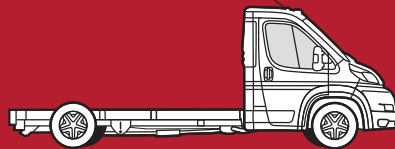
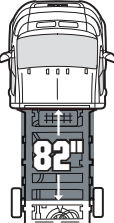
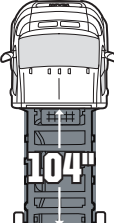
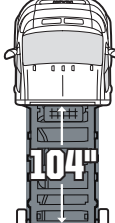
	1500		2500		3500		
	118" WB	136" WB	136" WB	159" WB	136" WB	159" WB	159" WB, EXTENDED
 <p><b>CARGO VAN</b> STANDARD ROOF</p>							
 <p><b>CARGO VAN</b> AVAILABLE HIGH ROOF</p>							
 <p><b>CREW VAN PACKAGE</b> HIGH ROOF ONLY</p>							
 <p><b>WINDOWED VAN</b> HIGH ROOF ONLY</p>							
 <p><b>CHASSIS CAB/CUTAWAY</b> STANDARD ROOF ONLY</p>	<p> <span style="display:inline-block; width:15px; height:15px; background-color:darkred;"></span> = CARGO LENGTH AT MAX CARGO HEIGHT  <span style="display:inline-block; width:15px; height:15px; background-color:orange;"></span> = CARGO LENGTH UNDER CREW SEATING (AT 49" WIDE)  <span style="display:inline-block; width:15px; height:15px; background-color:gray;"></span> = CAB-TO-AXLE LENGTH            WB = WHEELBASE         </p>						

**BUSINESS LINK**

The fast lane for small business.

#### THE DEALER NETWORK FOR YOUR BUSINESS.

Your **BusinessLink** dealer is committed to providing you, the small business owner, with the vehicle support you need for your business, from servicing all makes and models of your existing lineup to selling you the right vehicles needed to perform the work that you do. Your **BusinessLink** dealer provides priority service because we know downtime is costing you money. **BusinessLink** sales professionals are trained to properly “job-rate” the right vehicle for your work application and provide commercial finance options. New vehicle sales to qualified small business owners also include a free alternate transportation contract, in the event your vehicle is in for service.

Membership is free. Membership helps us to identify you as a small business owner so we can provide you with both the service you deserve and update you with offers that can help reduce the cost of doing business. Ask your **BusinessLink** dealer to register today.

**BusinessLink** has you covered.

- Full Range of FCA Commercial Vehicles
- Free Membership
- Priority Service
- Extended Service Hours
- Dedicated Staff of Commercial Vehicle Experts
- Free Alternate Transportation
- Commercial Incentives
- Expertise in Commercial Financing Options
- 24/7 Towing Service Available

For more information, go to [fcausfleet.com/programs/business-link-dealers.html](https://fcausfleet.com/programs/business-link-dealers.html) or call us toll-free at **877-2THELINK (877-284-3546)**.

## MAXIMIZE YOUR EXPERIENCE

**ON THE JOB**

#### INCENTIVES FOR SMALL BUSINESSES.

Running a business presents plenty of challenges. Like cutting costs, not corners. Like saving time and money while avoiding hassles. The **ON THE JOB**<sup>28</sup> commercial incentive program provides assistance in customizing and servicing your business vehicles.

**ON THE JOB**<sup>28</sup> allowances make your business more profitable!

- UP TO \$1,000 Commercial Graphics Program Allowances<sup>29</sup>
- UP TO \$1,000 Commercial Equipment/Upfit Allowances<sup>30</sup>

**CHRYSLER**  
CAPITAL

A commercial line of credit from Chrysler Capital is ideal for qualified business customers looking for a flexible, easy way to manage growing vehicle needs. Chrysler Capital streamlines the process—and with prequalification, you’re ready to buy a vehicle when you need it. Ask your **BusinessLink** dealer for details.





**BORN UNDER THE RAM LOGO.** Drive a pickup with total street cred—and then take it to the next level. Here is where you'll find an exclusive collection of the useful, the cool and the stylish—from clothing and caps to coolers and tools. Make the Ram identity part of your everyday lifestyle.



**RAM**

OFFICIAL BRANDED MERCHANDISE SITE

[ram.com/outfitter](http://ram.com/outfitter)

Ram Truck owners view their trucks as more than transportation, but as an extension of themselves. Check out an exclusive line of gifts and accessories for the Ram Truck enthusiast. From authentic apparel to rugged work gear, as well as electronics and office supplies, all lifestyle items are as distinctive as your Ram Truck.

available at  
**amazon**

[amazon.com/ramtruckstore](http://amazon.com/ramtruckstore)



For more information, visit  
[ram.com/promaster](https://ram.com/promaster)



1 Class is based on Large Commercial Van segment (Class 2). When properly equipped. See dealer for details. 2 Class is based on Large Van segment (Class 2) cargo van. When properly equipped. See dealer for details. 3 This system is an alert system for the front of the vehicle. It is not a substitute for active driver involvement. The driver must remain aware of traffic conditions and be prepared to use the brakes to avoid collisions. 4 Always check visually for vehicles prior to changing lanes. 5 Always check entire surroundings visually before proceeding. 6 Always drive carefully, consistent with conditions. Always wear your seat belt and obey traffic laws. 7 Always look before proceeding. An electronic drive aid is not a substitute for conscientious driving. Always be aware of your surroundings. 8 Traffic Sign Recognition is not a substitute for safe and attentive driving. Factors including weather and condition of the traffic sign can impact recognition and display of the sign. Always check traffic signs visually while driving. 9 This system is a driver convenience system, not a substitute for active driver involvement. The driver must remain aware of traffic conditions and be prepared to use the brakes to avoid collisions. 10 Always sit properly in designated seating positions with seat belts securely fastened at all times. 11 This system is a driver convenience system, not a substitute for active driver involvement. The driver must remain aware of traffic conditions and maintain control of the vehicle. 12 When properly equipped. See dealer for details. 13 Requires compatible iPhone. See dealer for phone compatibility. Data plan rates apply. Vehicle user interface is a product of Apple. Apple CarPlay is a trademark of Apple Inc. iPhone is a trademark of Apple Inc., registered in the US and other countries. Apple terms of use and privacy statements apply. 14 To wirelessly use Android Auto on your car display, you need a compatible Android smartphone with an active data plan. Android and Android Auto are trademarks of Google LLC. 15 All vehicles properly equipped to receive connected services come with a three-month trial of the full suite of Ram Connect services effective from the date of purchase or lease of a new vehicle. Enrollment in the trial is required to receive service. Upon expiration of the trial period, purchase of a subscription is required to continue or renew services. Ram Connect is available only on equipped vehicles purchased within the United States, Canada and Puerto Rico. Services can only be used where cellular coverage is available. See the applicable Terms of Service for complete terms and conditions, including service limitations. 16 Your service will automatically stop at the end of your trial subscription unless you decide to continue service. If you do not wish to enjoy your trial subscription, you can cancel it by calling the number below. **If you decide to continue service after your trial subscription, the subscription plan you choose will automatically renew thereafter and you will be charged according to your chosen payment method at then-current rates. Fees and taxes apply. Please see our Customer Agreement at [www.siriusxm.com](https://www.siriusxm.com) for complete terms and how to cancel, which includes calling us at 1-866-635-2349. All fees, content and features are subject to change. 17 Part numbers vary by wheelbase. 18 Available only at time of vehicle order. 19 Backed by the 3-Year/36,000-Mile Basic Limited Warranty. Visit [www.Mopar.com](https://www.Mopar.com) for complete details and a copy of the Basic Limited Warranty. 20 Check Owner's Manual for hitch type, load capacity and heavy-duty equipment required. Do not exceed rated tow capacity of the vehicle as equipped. Trailer may require items not supplied by Mopar. 21 Not available for vehicles equipped with 118-inch wheelbase. 22 Assumes properly equipped vehicle and 150-lb allowance for driver. Additional options, equipment, passengers and cargo weight must be subtracted. See dealer for details. 23 The Uconnect Phone requires a mobile phone equipped with the Bluetooth Hands-Free Profile. To check phone compatibility, please visit [www.UconnectPhone.com](https://www.UconnectPhone.com). 24 Check state and local laws regarding the use of remote start systems. 25 Vehicle must be locked and system activated for alarm to sound. 26 Measured from center cab back to center of rear axle. 27 Measured from center of axle to rear frame. 28 ON THE JOB is a retail incentive program; see your dealer for official rules. Inquire about eligibility by calling 877-ONTHEJOB or by logging on to [fcausfleet.com/programs/business-link-dealers.html](https://fcausfleet.com/programs/business-link-dealers.html). The purchaser or lessee must be a qualified commercial customer for more than 30 days prior to the date of the vehicle purchase. An official ON THE JOB Customer Acknowledgment Form must be signed by the customer (provided by the dealer). 29 Allowance varies by graphic program. See dealer for details. Take retail delivery by 01/03/2023. 30 Allowance varies by upfit and model. See dealer for details. Take retail delivery by 01/03/2023.**

©2022 FCA US LLC. All Rights Reserved. Ram, Mopar, Ram ProMaster, the Ram's Head logo, the BusinessLink design, LaneSense, ParkSense, ParkView, Pentastar and Uconnect are registered trademarks, and DriveAbility & design and the On The Job design are trademarks of FCA US LLC. Chrysler Capital is a registered trademark of FCA US LLC and licensed to Santander Consumer USA Inc.

Sortimo is a registered trademark of Sortimo International GmbH. Knapheide is a registered trademark of Knapheide Manufacturing Company. Facebook and logo are registered trademarks of Facebook, Inc. The Twitter logo is a service mark of Twitter, Inc. YouTube and other marks are registered trademarks of Google LLC. Instagram and logo are registered trademarks of Instagram, Inc. Bluetooth is a registered trademark of Bluetooth SIG, Inc. SiriusXM Connected Vehicles Services Inc. Sirius, XM, SiriusXM and all related marks and logos are trademarks of Sirius XM Radio Inc. Snoeks Automotive is a trademark of Snoeks Beheer B.V. LinkedIn, the LinkedIn logo, the IN logo and InMail are registered trademarks or trademarks of LinkedIn Corporation and its affiliates in the United States and/or other countries. TikTok is a trademark of Bytedance Ltd. "TomTom" is a registered trademark of TomTom International BV. Amazon and all related logos and marks are trademarks of Amazon.com, Inc. or its affiliates.

About this catalog: since the time of publication, some of the information you'll find in this catalog may have been updated. Ask your dealer for details. Some of the equipment shown or described throughout this catalog may be available at extra cost. Specifications, descriptions, illustrative materials and all competitive comparisons contained herein are as accurate as known at the time this publication was approved. FCA US LLC reserves the right to discontinue models at any time or change specifications without notice or without incurring obligation. Options may be required in combination with other options. For the price of the model with the equipment you desire, or verification of specifications contained here, see your Ram dealer.



Join fellow Ram enthusiasts and tell your story by posting comments, participating in discussions, and sharing your photos and videos. Join our community on Facebook, Twitter, YouTube, TikTok, Instagram and LinkedIn.

Explore Ram Life at [ram.com/ram-life.html](https://ram.com/ram-life.html)

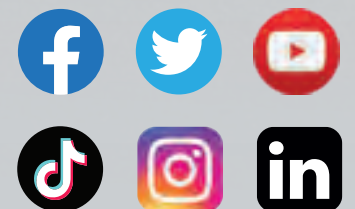

Ram is a registered trademark of FCA US LLC.

74-383-2227\_04/22