



SOLUTIONS FOR THE WORLD YOU DRIVE IN.

At General Motors we are 100 percent committed to building vehicles that answer your specific needs. Because you demand more of your vehicle than ever before, we're committed to putting more of what you want into every vehicle we make.

VALUE

Value means much more than simply the price you pay for a vehicle. We are particularly proud of the value you receive for your money when you choose a General Motors vehicle – the unique combination of style, performance, safety, quality and functionality that sets GM's diverse model lineup apart from the rest.

QUALITY

If you're looking for a vehicle that's built to exceptionally high standards, look no further than GM's long list of quality and dependability awards, media accolades and consumer recommendations – as well as the fact that GM builds the most dependable, longest-lasting full-size pickups on the road.*

SAFETY

General Motors is the only automotive manufacturer committed to offering a full range of cars, trucks and SUVs that provide safety protection before, during and after a collision. In addition, GM builds 26 vehicles that have earned U.S. Government five-star frontal or side crash test ratings for 2006 models.**

FUEL ECONOMY

We know how important fuel efficiency is today. GM has it covered by offering more cars that get better than 7.0 L/100 km or 40 mpg in highway† driving than any other automaker in Canada. In addition, GM offers 15 models with Active Fuel Management™ fuel-saving technology – and 17 models that can run on E85 ethanol fuel.

INNOVATIVE DESIGNS

It required ingenuity to bring utility and dramatic style together in the Chevrolet HHR. And it required pure creativity to execute the flawless lines and purposeful design of the Pontiac Solstice open-air roadster. At GM, we break the mould to develop new designs that give you more range of selection than ever before.

FEATURES

GM keeps you ahead of the curve, by adding the features that really make a difference to your driving experience. Features like OnStar – the first comprehensive in-vehicle communications and assistance service. And XM Satellite Radio – the largest satellite radio provider in the world – that's now offered on more than 50 GM vehicles.

*Dependability based on longevity; 1988-July 2005 full-size Chevrolet and GMC light-duty pickup registrations, including chassis cabs. Sources: R.L. Polk Canada, Inc. National Vehicle Population Profile – Canadian Vehicles in Operation as of July 1, 2005. Based on % of vehicles remaining in operation, weighted on age of vehicle.
**U.S. Government ratings are part of the National Highway Traffic Safety Administration's (NHTSA's) New Car Assessment Program (safercar.gov).
†Based on Natural Resources Canada's 2006 Fuel Consumption Guide's rating available at time of printing.
™© 2005, VANOC. Used under License.

CHEVROLET PONTIAC BUICK GMC SATURN HUMMER SAAB CADILLAC

gmcanada.com



PONTIAC SOLSTICE



FEEL FREE

2007



FEEL FREE

CLEAR YOUR SCHEDULE. On the one hand, there's the world as you've always known it, full of deadlines, budgets, obligations, commitments and responsibilities.

And on the other, there's Pontiac Solstice.

Solstice is what you might call a freedom machine. It's all about you. Your style. Your destination. Your route. Your pace.

And for 2007, all this freedom is available in two distinct forms. With its highly responsive 177 horsepower ECOTEC engine and solid chassis, the original Solstice is all about pure driving pleasure. There's also a new Solstice GXP designed especially for those who demand a higher level of excitement. It comes with a turbocharged version of the ECOTEC engine that bumps output all the way up to 260 horsepower and 260 lb.-ft. of torque. Whichever one you choose, you're in for a great ride.

Solstice. Experience what it means to feel free.

For more information about Solstice, visit our website at solstice.gmcanada.com

PONTIAC  **IGNITE THE FEELING**



SOLSTICE GXP

INTRODUCING A MORE POWERFUL KIND OF FREEDOM. Capable of accelerating from zero to 96 km/h (60 mph) in under 5.5 seconds, the new Solstice GXP takes the Solstice concept to thrilling extremes. Its turbocharged 2.0-litre engine produces more power per litre of displacement than any powerplant in General Motors history. The GXP engine also generates 260 lb.-ft. of torque at a low 2500 rpm, which translates into right-now acceleration in real world driving. Keeping all that muscle firmly under control are a host of chassis upgrades, including four-wheel disc brakes with ABS, a Sport suspension and a StabiliTrak vehicle stability control system. Solstice GXP has a powerful sense of style, too, with unique front and rear styling and a gleaming dual-outlet exhaust.



FOLDING ROOF

THE CHOICE IS YOURS. Imagine being free to tailor your driving experience to suit the weather, the road conditions or, simply, your mood. Solstice's weatherproofed, sound-baffled convertible top lets you do precisely that.

Leave the top in place and you enjoy virtually all the privacy and weather protection of a hardtop coupe. Drop the top and the entire driving experience instantly becomes more immediate, more sensuous – and more sheer fun.

Best of all, the transition from top-up to top-down is quick and virtually effortless. And Solstice includes a standard rear-hinged deck-lid that conceals the roof when it's down to preserve the car's stunning good looks.

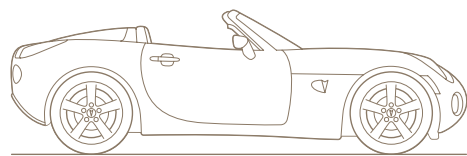
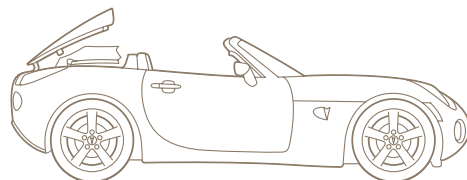
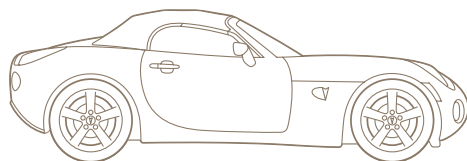

Solstice's convertible top provides excellent rearward visibility in all four seasons, thanks to a standard glass rear window complete with electric defogger. When it's down, the top tucks neatly away under the rear-hinged deck-lid.



GXP INTERIOR

Solstice GXP supplements Solstice's cleanly styled, driver-focused interior with a wide range of amenities, including a unique instrument panel with satin nickel trim and a Driver Information Centre. Power assists for the windows and door locks, a premium sound system with XM Satellite Radio and a Monsoon seven-speaker audio system are just a few of GXP's other premium standard features.

COMFORT FOR TWO

UPDATING THE ROADSTER TRADITION. Roadsters are loved for many reasons. One of them is the way they let you share the fun when you take a companion along for the ride.

Solstice updates that time-honoured tradition with an interior that offers real comfort for driver and passenger alike. Its well-bolstered bucket seats don't just help keep you in place when you're playing in the twisty bits. They've also been engineered to help you enjoy longer journeys, with all the support you crave. Stylish Ebony cloth is standard in both models. If you prefer leather-appointed seating it's available in a model-specific choice of colour treatments.

Solstice's seats have your protection in mind, too. Pontiac's engineers designed the seats with taller-than-normal head restraints to help guard against whiplash in rear-end collisions.

FEATURES

- Integrated instrument panel, centre stack and console
- Dual map lights
- Locking glovebox
- PASS-Key III+ theft-deterrent system
- Power Package with power windows, power door locks, power mirrors and remote keyless entry – standard on Solstice GXP, available on Solstice
- Available leather-appointed seating
- Available OnStar.

DRIVER COCKPIT

LIBERATE YOUR INNER DRIVER. The instant you slip into Solstice's surprisingly roomy cockpit, one thing is clear. This is one amazing driver's car. In front of you, there are large, clear analogue gauges positioned perfectly for quick viewing. The steering wheel in your hands requires just 2.7 turns lock-to-lock, which translates into extraordinary responsiveness. The throttle and brake pedals are ideally placed for heel-and-toe shifting, and the short-throw shifter for the standard Aisin five-speed manual transmission feels so smooth and intuitive, everyone will find themselves shifting like experienced racers. Of course, there's also an available electronically controlled five-speed automatic gearbox for those who prefer to let technology do their shifting for them. Get in. And unleash your passion for driving.



GXP GAUGES
Solstice GXP features a unique analogue gauge cluster with stylish satin nickel accents. A Driver Information Centre with a turbo boost readout is also included.



POWER

URNS GASOLINE INTO ADRENALINE. To create just the right engine for Solstice, Pontiac's engineers started with the proven ECOTEC 4-cylinder powerplant. They bumped its displacement up to 2.4 litres. Then, for good measure, they added variable valve timing (VVT), a high-tech feature that increases power and efficiency across a wide range of operating speeds. In the process they liberated a lot of power – 177 horsepower and 166 lb.-ft. of torque, to be exact. In a car that weighs just 1330 kg (2933 lb.), the result is a drive you simply have to experience to appreciate.

AND MORE POWER

PERFORMS UNDER PRESSURE. The turbocharged 2.0 litre ECOTEC powerplant tucked under the hood of Solstice GXP uses some of today's most advanced engine technologies to extract tremendous power and torque from an engine of modest dimensions. Its turbocharger is a dual-scroll unit that features a lightweight turbine for lightning-fast response. There's also an air-to-air intercooler that reduces the temperature of the intake charge for more efficient combustion. Variable Valve Timing (VVT), electronic throttle control and direct injection technology are among the other high-tech systems that make this engine's impressive outputs possible.

The Solstice GXP engine combines high-performance and startling fuel efficiency, thanks in part to direct injection technology. This injection system delivers fuel directly into the combustion chambers, resulting in a more complete burn of the air-fuel mixture. It's a cutting-edge technology that significantly increases efficiency compared with conventional fuel injection systems.

Open the front-hinged clamshell hood and show off Solstice GXP's 260 horsepower engine to your friends. Or close it and dazzle them with its sub-5.5 second 0-96 km/h (60 mph) acceleration.

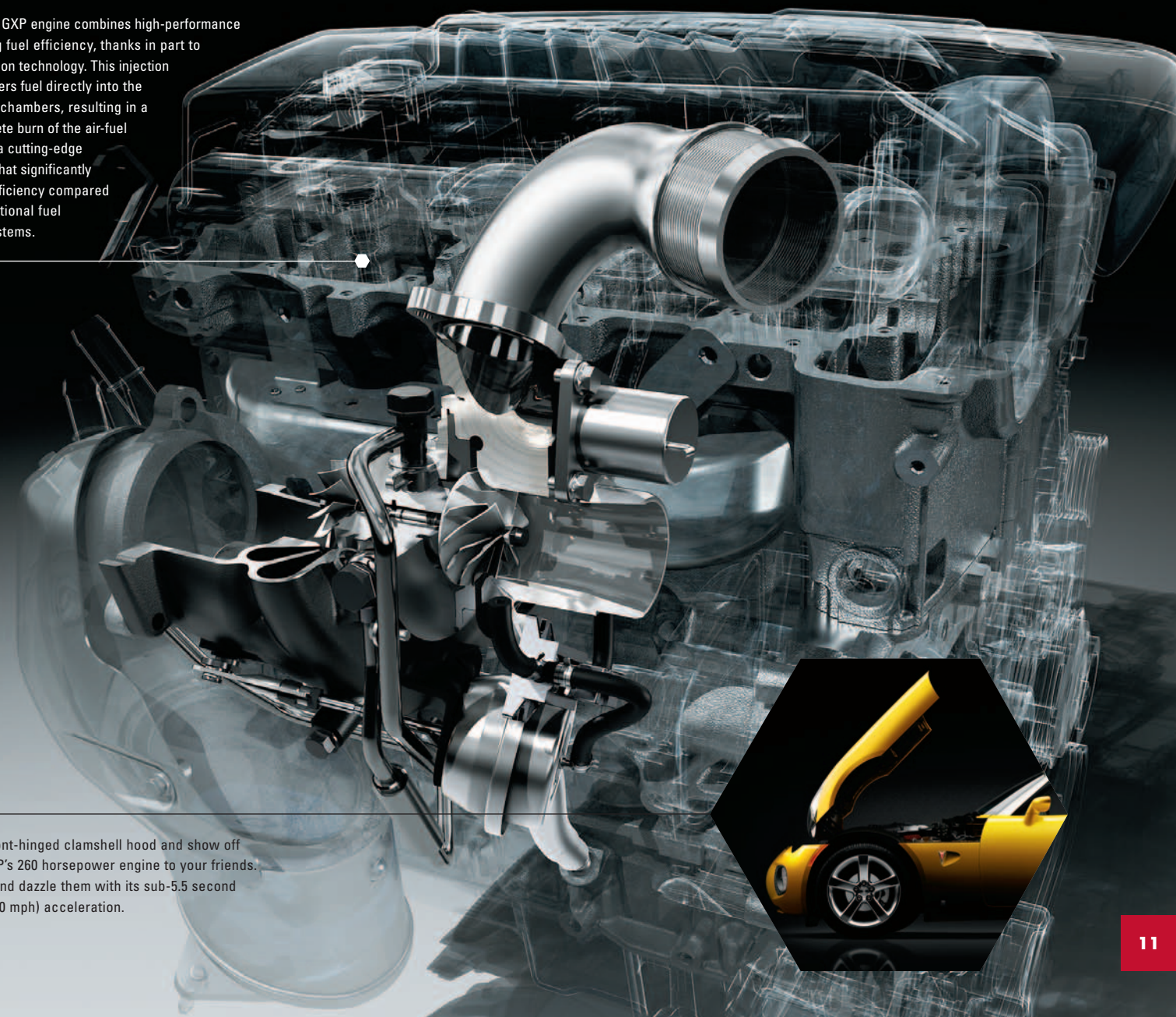

TECHNOLOGY

IT'S GOOD TO THE BONE. That invigorating feeling you get driving a Solstice is a direct result of Pontiac's driver-centred engineering. Take the car's high-tech rear-wheel drive architecture, for example. Solstice was developed from the outset as a roadster, so its structure is solid and unbending. This dedicated sports-car platform also distributes Solstice's weight roughly 50/50 between the front and rear wheels, for near-perfect

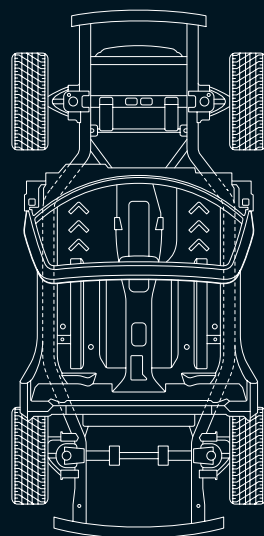

Solstice's computer-designed architecture is both extremely strong and light in weight. Its extraordinary resistance to bending enhances ride and handling characteristics and contributes to a feeling of solid quality.

handling balance. The car's broad stance and low centre of gravity play their part, too. Then there's the fully independent suspension – specially tuned and supplemented with a StabiliTrak vehicle stability control system on Solstice GXP – which helps extract a maximum of agility and roadholding from the car's architecture. Put it all together and you've got a driving experience you may just find addictive.

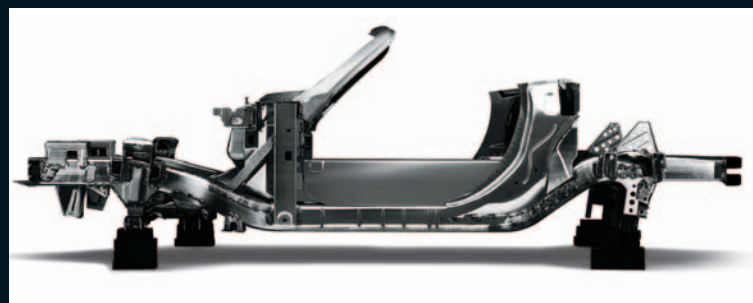

Solstice is built on a computer-engineered vehicle platform that's among the most advanced of its kind in the world. Highlights include strong and precise full-length hydroformed frame rails and a reinforced centre driveshaft tunnel that adds to the body's overall structural stiffness. The engine is secured to the chassis via hydraulic mounts that help keep vibration and noise from reaching the interior.

NOW FOR MORE CHOICES

DRESS IT TO THE NINES. With GM Accessories, you're free to customize your new Solstice for even more style and fun. GM Accessories are the only accessories that are integrated into the process of designing your vehicle, ensuring excellent fit, finish and functionality. And only GM Accessories are backed by GM's 3-year/60,000 km New Vehicle Limited Warranty.* They can also be included in your new-vehicle lease or finance agreement through GMAC. Ask your dealer for a complete list of the GM Accessories available for your Solstice. Or visit gmcanada.com

GM Accessories available for Solstice include:

- 18" cast/chrome wheels
- Performance suspension kit
- Performance air intake
- Catback exhaust system
- Exhaust tips
- Windblocker
- Tonneau cover
- Custom vinyl floor mats
- Smoker's Package
- Front end cover.

*Whichever comes first, when permanently installed by the dealer at the time you purchase or lease your new vehicle.



THE GM WARRANTY:¹

The New Vehicle Limited Warranty is your promise of total warranty protection. It applies to the first owner and all future owners of the vehicle, and covers repairs to correct vehicle defects related to materials or workmanship during the warranty period.

The warranty includes:

- 3-year/60,000 km* Base warranty coverage
- 6-year/160,000 km* rust-through perforation coverage
- 8-year/130,000 km* coverage on catalytic converters and powertrain control modules (PCMs).

¹Conditions and limitations apply. *Whichever comes first.

OTHER OWNERSHIP PRIVILEGES AND PROGRAMS:¹

- **Roadside Assistance** – 24/7 service via toll-free number during the Base warranty period, anywhere in Canada or the United States
- **Courtesy Transportation** – may be offered during the Base warranty period
- **GM Protection Plan (GMPP)** – the only extended services contract backed by the resources and commitment of General Motors, GMPP may be purchased at the time of your sale or lease, or subsequently during the Base warranty period¹
- **GM Goodwrench Service** – with GM-certified technicians and GM-approved parts, nobody knows your GM vehicle better.

¹Conditions and limitations apply.

TO HELP YOU PURCHASE OR LEASE A NEW VEHICLE:

- **GMAC Financing** – on the spot financing at your GM dealership¹
- **GMAC SMARTLEASE** – a smart alternative to traditional financing¹
- **GM Student Bonus Program** – GM will cover the first two purchase finance or lease payments and the lease security deposit on eligible new GM vehicles for students and recent graduates of high school, college or university¹
- **The GM Card** – eligible cardholders may be able to redeem up to \$3500 on GM Card[®] Earnings toward the total purchase price or lease down payment on selected vehicles¹. For more information on The GM Card please call 1-800-461-3279.

¹Conditions and limitations apply. ²Subject to eligibility.

INFORMATION RESOURCES:

- You can find more information about these programs from your GM dealer, or at these information centres:
- The GM website at gmcanada.com
 - The GM Customer Communication Marketing Centre at 1-800-GM-DRIVE (1-800-463-7483 or 1-800-263-3830 for TDD users)
 - For information about GMAC visit gmcanada.com or call 1-800-616-4622.



ONSTAR

OnStar[®] uses advanced communications technology to enhance your safety, security and convenience. OnStar Advisors can provide a wealth of information and perform a variety of diagnostic services. They can also provide assistance in an emergency. No wonder more than 4 million people have become OnStar subscribers and over 12 million calls are made each month on the built-in voice-activated, hands-free system. OnStar and one year of the Safe & Sound Plan are available on all Solstice models. See your dealer for more information on plans and services.



¹OnStar services require vehicle electrical system (including battery), wireless service, and GPS satellite signals to be available and operating for features to function properly. Not all OnStar features are available on all vehicles. OnStar acts as a link to existing emergency service providers. OnStar Hands-Free Calling requires a Hands-Free enabled vehicle, prepaid minutes and existing OnStar service contract. Subscription Service Agreement required.

XM SATELLITE RADIO

What's convinced more than six million people to subscribe to XM Satellite Radio? How about the largest playlist on the planet, with musical genres that span everything from decades to dance, rock to rap and country to classical – broadcasting the most commercial-free music in digital quality sound? Or is it the news, talk, comedy and sports channels – including more than 1,000 NHL games – and all available from coast to coast? XM has revolutionized radio as we know it. And now you can enjoy XM Satellite Radio in your next General Motors vehicle – GM is the first automaker to offer factory-installed satellite receivers. Ask your Pontiac dealer for more information.



¹Includes three free trial months beyond which service fees apply. Available in 10 Canadian provinces and 48 contiguous United States.

PONTIAC SOLSTICE SPECIFICATIONS

SAFETY AND SECURITY	CONVERTIBLE	CONVERTIBLE GXP
Air bags – dual stage, driver and passenger, frontal with Passenger Sensing System	S	S
Door locks – power	0 ¹	S
Headlights – Daytime Running Lights with automatic light control	S	S
Keyless entry system – remote	0 ¹	S
OnStar In-Vehicle Communications and Assistance Service – includes one-year of the Safe & Sound Plan	0 ²	0 ²
Safety belts – with pre-tensioners	S	S
Theft-deterrent system – PASSKey III+, immobilizer	S	S

MECHANICAL	CONVERTIBLE	CONVERTIBLE GXP
Battery – with run-down protection	S	S
Brakes – power, 4-wheel disc	S	S
Brakes – 4-wheel anti-lock braking system (ABS)	0	S
Differential – limited slip	0	S
Drive – rear-wheel	S	S
Engine – 2.4L ECOTEC I-4 VVT with SFI Horsepower – 177 @ 6600 rpm; Torque – 166 lb.-ft. @ 4800 rpm	S	–
Engine – 2.0L turbocharged ECOTEC I-4 VVT with SIDI Horsepower – 260 @ 5300 rpm; Torque – 260 lb.-ft. @ 2500 rpm	–	S
Exhaust system – aluminized stainless steel	S	S
Exhaust system – single high-polished tip	S	–
Exhaust system – dual high-polished tips	–	S
StabiliTrak – vehicle stability control system	–	S
Steering – power, rack-and-pinion	S	S
Suspension – 4-wheel independent with Bilstein monotube shocks	S	S
Suspension – Sport	–	S
Transmission – 5-speed short-throw manual (Aisin)	S	S
Transmission – 5-speed automatic	0	0
Club Sport Package – includes Sport suspension, anti-lock brakes and a limited-slip differential ³	0	–

EXTERIOR	CONVERTIBLE	CONVERTIBLE GXP
Convertible top – cloth top with glass rear window	S	S
Convertible top – premium acoustic headliner	0	0
Door handles – chrome	S	S
Fascias – front and rear body-colour	S	S
Fascias – unique GXP fascias	–	S
Fog lights	0 ⁴	S
Glass – Solar Ray, tinted	S	S
Mirrors – folding, left and right remote	S	–
Mirrors – folding, left and right power remote control	0 ¹	S
Tires – P245/45R18 all-season performance	S	–
Tires – P245/45R18 performance (summer)	–	S
Tire repair – sealant and inflator kit	S	S
Wheels – 18" x 8" flangeless silver-painted aluminum (A)	S	–
Wheels – 18" flangeless polished aluminum (B)	0	S
Wheels – 18" flangeless chromed aluminum (C)	0	0
Windshield wipers – 2-speed with speed-sensitive, variable delay (intermittent)	S	S

INTERIOR	CONVERTIBLE	CONVERTIBLE GXP
Air conditioning – manual	0	0
Auxiliary power outlet	S	S
Console – with cupholders	S	S
Cruise control – steering wheel-mounted, electronic with resume, coast and decelerate/accelerate features	0 ⁴	S
Defogger – electric rear-window	S	S
Floor mats – colour-keyed	0	–
Floor mats – colour-keyed with GXP logo	–	S
Instrumentation – chrome-accented analogue cluster, (includes speedometer, tachometer, and fuel gauge)	S	–
Instrumentation – Nickel-accented analogue cluster, (includes speedometer, tachometer and fuel gauge) and Driver Information Centre with turbo boost display	–	S
Lights – delayed entry/exit with ignition key removal, dual map lights, theatre dimming and trunk	S	S
Pedals – sport metallic	0	0
Steering column – tilt adjustable	S	S
Steering wheel – Sport, 3-spoke	S	–
Steering wheel – Sport, 3-spoke leather-wrapped with cruise control, Driver Information Centre and sound system controls	0 ⁵	S
Sunshades – LH and RH: driver vanity mirror	S	S
Trunk – release, power remote	S	S
Windows – power	0 ¹	S
Convenience Package – includes cruise control, Driver Information Centre and fog lights	0	S
Power Package – includes power windows, power door locks, remote keyless entry system and power remote control mirrors	0	S
Smoker's Package – includes ashtray and lighter*	0	0

SEATS	CONVERTIBLE	CONVERTIBLE GXP
Cloth reclining bucket seats – with seatback pockets	S	S
Leather Package – includes leather-appointed seating areas, leather-wrapped steering wheel with cruise control, Driver Information Centre and sound system controls	0 ⁶	0

SOUND SYSTEMS	CONVERTIBLE	CONVERTIBLE GXP
All Solstice sound systems include an electronically tuned AM/FM stereo with seek, scan, digital clock and auxiliary audio input jack		
AM/FM stereo with CD player	S	–
AM/FM stereo with CD player, MP3 playback, auto tone control, speed-compensated volume control, Radio Data System (RDS) and TheftLock	0	S
AM/FM stereo with in-dash 6-disc CD changer, MP3 playback, auto tone control, speed-compensated volume control, Radio Data System (RDS) and TheftLock	0 ⁷	0
XM Satellite Radio**	0	S
6-speaker sound system	S	–
Monsoon 7-speaker performance sound system with integrated subwoofer	0 ⁸	S

1 Included with Power Package.
 2 Includes interior rear-view mirror with dual map lights. Requires Power Package and premium acoustic headliner.
 3 Requires manual transmission and Ebony cloth trim. No other options available.
 4 Included with Convenience Package.
 5 Included with Leather Package.
 6 Includes Convenience Package.
 7 Requires Monsoon 7-speaker sound system.
 8 Requires either up-level sound system.
 *Regular production accessory, dealer-installed.
 **Includes three free trial months beyond which service fees apply. Available in 10 Canadian provinces and 48 contiguous United States.
 S – Standard. 0 – Optional individually or in combination with other optional equipment.

DIMENSIONS	CONVERTIBLE	CONVERTIBLE GXP
EXTERIOR, mm (in.)		
Wheelbase	2415 (95.1)	
Length	3992 (157.2)	
Width	1810 (71.3)	
Height	1273 (50.1)	
Front tread	1542 (60.7)	
Rear tread	1560 (61.4)	

INTERIOR, mm (in.)	CONVERTIBLE	CONVERTIBLE GXP
Headroom	975 (38.5)	
Legroom	1086 (42.7)	
Shoulder room	1332 (52.4)	
Hip room	1284 (50.6)	

CAPACITIES/WEIGHT	CONVERTIBLE	CONVERTIBLE GXP
Trunk, L (cu. ft.) – top up	153 (5.4)	
Fuel tank capacity, L (imp. gal.)	52 (11.5)	
Curb weight (est.), kg (lb.) – manual transmission	1330 (2933)	
Convertible	1356 (2990)	

TOWING
2.4L ECOTEC I-4 VVT 3.91 final drive ratio; trailer towing not recommended
2.0L turbocharged ECOTEC I-4 VVT 3.73 final drive ratio; trailer towing not recommended

WHEELS



A – 18" flangeless silver-painted aluminum



B – 18" flangeless polished aluminum



C – 18" flangeless chromed aluminum

EXTERIOR COLOURS

Colours may not be exactly as illustrated due to restrictions of the printing process. Please see your Sales Consultant for specific colour and model availability.



FABRICS

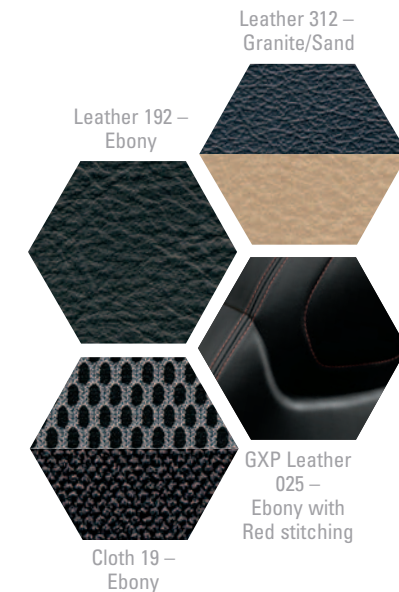

EXTERIOR/INTERIOR COLOUR COMPATIBILITY	Convertible	GXP Convertible
▼ Exterior Interior ►	19 – Ebony	312 – Granite/Sand
25 – Deep	•	•
34 – Mean*	•	•
38 – Envious	•	•
41 – Mysterious	•	•
42 – Sly	•	•
50 – Pure	•	•
67 – Cool	•	•
74 – Aggressive	•	•

*Available at extra cost.

CONVERTIBLE TOP FABRICS

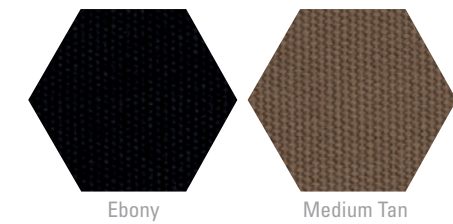

Either top colour is available with every exterior colour.

A WORD ABOUT THIS BROCHURE

Some of the equipment shown or described throughout this brochure may be available at extra cost. We have tried to make this brochure comprehensive and factual. We reserve the right, however, to make changes at any time, without notice, in prices, colours, materials, equipment, specifications, models and availability. Specifications, dimensions, measurements, ratings and other numbers in this brochure and other printed materials provided at the dealership or affixed to vehicles are approximates based upon design and engineering drawings and prototypes and laboratory tests. Your vehicle may differ due to variations in manufacture and equipment. Since some information may have been adapted since the time of the printing, please check with your GM dealer for complete details. General Motors of Canada Limited reserves the right to lengthen or shorten the model year for any product, for any reason, or to start and end model years at different times.

A WORD ABOUT ASSEMBLY

GM vehicles are equipped with engines and components produced and assembled by different operating units of General Motors, its subsidiaries and suppliers and these engines and components may change or be obtained from different sources from time to time. All such engines and components are approved for use in GM vehicles. Certain equipment ordered may be unavailable at the time of assembly and we suggest that you verify that your vehicle includes the equipment you ordered, or if there are changes, that they are acceptable to you.

TRADEMARKS

The marks appearing in this brochure including, but not limited to: General Motors, GM, the GM Canada emblem, the GM Canada website address, the GM Accessories logo, Buick, Cadillac, Chevrolet, GMC, HUMMER, Pontiac, the Pontiac emblem, Saab, Saturn, HHR, Solstice and their respective logos, emblems, slogans and vehicle model names and body designs; and other marks such as Solar-Ray, StabiliTrak and SMARTLEASE are trademarks of General Motors Corporation and/or General Motors of Canada Limited, its subsidiaries, affiliates or licensors. GMAC is a registered trademark of the General Motors Acceptance Corporation. OnStar, the OnStar logo and the OnStar button are registered trademarks of the OnStar Corporation. PASS-Key III+, Monsoon and TheftLock are registered trademarks of Delphi Automotive Systems. Radio Data System (RDS) is a registered trademark of the U.S. National Association of Broadcasters. The XM name and related logos are registered trademarks of XM Satellite Radio Inc.

COPYRIGHT

©Copyright 2006 General Motors of Canada Limited. All Rights Reserved. All text, images, graphics, and other materials in this brochure are subject to the copyright and other intellectual property rights of General Motors Corporation and/or General Motors of Canada Limited. These materials may not be reproduced, distributed or modified without the express written permission of General Motors Corporation and/or General Motors of Canada Limited.