



facebook.com/chevroletcanada



twitter.com/chevroletcanada



youtube.com/chevroletcanada

[CHEVROLET.CA](https://chevrolet.ca)

190-14-B-008E

CORVETTE / 2014



2014

CORVETTE

CHEVROLET.CA

FIND *NEW* ROADS™



WHY JUST GO FROM A TO B



WHEN IMAGINATION CAN TAKE YOU EVERYWHERE

The road. A simple path, really. And yet it's come to mean so much more. Perhaps the real reason roads are special is that every road leads us to someplace we're not – but could be. At Chevrolet, roads are our springboards. They challenge us, taunt us and guide us to create better, more exciting, more ingenious ways to move through life. Roads drive us to places we've never been before. And we'll never stop seeking out new ones.

CORVETTE

PRECISION It isn't just a word. For the designers of the all-new 2014 Corvette Stingray, it was a mantra. Throwing off the constraints of tradition, our engineers started from scratch to build a revolutionary sports car with the performance prowess, aesthetic impact and fine craftsmanship worthy of the Stingray emblem.



Corvette Stingray Coupe in Cyber Grey Metallic with available Z51 Performance Package and available visible carbon-fibre roof panel.



CAN YOU HANDLE THE PRECISION? Born through a synthesis of precision engineering and racing technology, the 2014 Corvette Stingray is a stunning argument against the ordinary. A lighter, more rigid aluminum space frame replaces its predecessor's steel frame. The use of carbon-fibre and carbon-nano-composite structures further reduces weight to achieve optimal handling, balance and acceleration.

EVERY LINE MATTERS Executed with beauty and proportion, every millimetre of Stingray serves its purpose. Geometric shapes transition smoothly from soft curve to crisp edge. Air flows effortlessly

to reduce drag and optimize performance. Increased downforce keeps the vehicle planted, while functional exterior vents create an airflow to reduce lift and minimize drag. The advanced ventilation systems help air flow from front to back, cooling critical components to improve vehicle handling. Stunning design, meet racing strategy.

WORTHY OF A LEGENDARY LINEAGE This Corvette marks the seventh generation of an iconic sports car backed by 60 years of tradition. But the Stingray is designed to challenge every expectation.

Corvette Stingray Coupe in Cyber Grey Metallic with available Z51 Performance Package and available visible carbon-fibre roof panel.



HOW DO YOU TOP A STINGRAY? YOU DECIDE.

COUPE AND CONVERTIBLE AS ONE For the first time ever, the Corvette Coupe and Convertible both use an identical rigid aluminum frame structure. Designed as an open-top vehicle from the outset, no additional reinforcements are required. The vehicle remains a pure, precision-born machine.

RACE THE WIND To some drivers, the Convertible Stingray is the only Stingray. This year, the Convertible features a fully electronic top, without manual mechanical latches, that can be lowered remotely using the key fob or while driving at speeds up to 50 km/h. With the top up, a thick design ensures maximum sound absorption for a quiet cabin. And when you decide to put the top down, it hides beneath a body-colour tonneau cover that flows down in a waterfall design between the seats.

OPEN-TOP COUPE The Stingray Coupe can also become an open-top vehicle, with a standard carbon-fibre roof panel so light just one person can remove it and stow it in the trunk. Available removable roof panel options include: body colour, visible carbon fibre and transparent.

Corvette Stingray Convertible in Cyber Grey Metallic with available Z51 Performance Package and available Torque Directional accessory wheels in Silver and Corvette Stingray Coupe in Laguna Blue Tintcoat (extra-cost colour) with available Z51 Performance Package and available performance exhaust.



Corvette Stingray Convertible 3LT interior in Kalahari with available Competition Sport seats with available sueded microfiber seat inserts, available Sueded Microfiber-Wrapped Upper Interior Trim Package and available 6-speed paddle-shift transmission with automatic mode.



THE JOURNEY BEGINS IN THE COCKPIT A performance vehicle is experienced from the driver seat, and Stingray has a cockpit worthy of a fighter jet. Illuminated by innovative digital features and intelligent driver controls, it's a stunning change from your typical interior scenery. A sweeping free-form line spans the instrument panel and flawlessly carries over into the door trim and console. Every millimetre is imbued with a deep respect for authentic materials. Real aluminum. Available carbon fibre. Available hand-selected leather. This is Corvette, elevated to a whole new level.

CAREFULLY CRAFTED, BEAUTIFULLY DETAILED The available hand-stretched, leather-wrapped instrument panel is hand-sewn with an eye to meticulous fit and finish. Lightweight aluminum accents adorn the doors, pedals, gearshift and cockpit instrumentation. A smaller, race-inspired steering wheel enhances grip and driving feel, featuring paddles that initiate Active Rev Matching on the manual transmission or manual shifting on the available 6-speed paddle-shift transmission with automatic mode. You can even upgrade your experience with carbon-fibre trim and Sueded Microfibre-Wrapped Upper Interior Trim Package.

LUXURY, MEET TECHNOLOGY The intuitive instrument cluster bears two ultra-bright 203 mm (8-in.) diagonal high-definition LED screens. The centre console entertainment interface features a retractable, tablet-inspired touch-screen. And an available colour Head-Up Display (HUD) projects critical data into the driver's line of vision on the windshield.

Corvette Stingray 3LT interior in Brownstone features sueded microfibre accents on the door panels and instrument panel. Shown with available sueded microfibre seat inserts and Sueded Microfibre-Wrapped Upper Interior Trim Package and available 6-speed paddle-shift transmission with automatic mode.



Left: Corvette Stingray gearshift shown wrapped in standard leather with contrasting stitching. When equipped with available Competition Sport seats and available sueded microfibre seat inserts, the gearshift and steering wheel are also wrapped in sueded microfibre with black stitching (not shown).

Right: Corvette Stingray 3LT interior in Kalahari with available Competition Sport seats and available sueded microfibre seat inserts.

STINGRAY PUTS YOU FRONT AND CENTRE Performance driving is experienced from the interior, so every line, every stitch and every accent must honour craftsmanship – and serve the driver.

GRAND TOURING SEATS The completely redesigned GT seat is mounted on a lightweight magnesium frame and cradles the driver for optimal comfort and support. Precision hand stitching finishes each and every contour. Premium natural-grain Napa leather is included with 3LT.

COMPETITION SPORT SEATS An available Competition Sport seat builds on the same lightweight magnesium frame. This seat provides maximum support for cornering, with more pronounced side bolsters designed for high-performance driving on the track. Upgrades to sueded microfibre inserts are available for the seats and include sueded microfibre wrap for the steering wheel and gearshift.

Camouflaged 2014 Corvette Stingray undergoing testing at Road Atlanta.

EVERY GRAM EARNED ITS WAY ONTO THE CAR

Influenced by Corvette Racing technology, the 2014 Corvette Stingray was designed to be an instrument of precision – and light, stiff materials make all the difference. Aluminum and carbon fibre contribute to a 50/50 weight distribution and a world-class power-to-weight ratio for optimal handling and acceleration. The all-aluminum space frame structure is 57% stiffer and 45 kg (100 lb.) lighter than the steel-frame sixth-generation Corvette.

REVOLUTIONARY LIGHTWEIGHT MATERIALS

Stingray also makes judicious use of carbon fibre to further reduce weight and improve handling. A carbon-fibre removable roof panel, a carbon-fibre hood, as well as carbon-nano-composite body structures optimize weight balance and centre of gravity.

ENGINEERED TO LEAVE NOTHING BEYOND YOUR CONTROL

On its journey to reinventing a legend, Stingray underwent stringent performance trials. On the track at Road Atlanta, engine temperatures were pushed to the max during repeated hot laps. On the roads of the real world, camouflaged test prototypes blurred past onlookers to ensure the same performance outcomes. And in the lab, tilt-dyno testing simulated extreme driving conditions to test engine durability and resilience.





Corvette Stingray Coupe in Cyber Grey Metallic with available Z51 Performance Package and available visible carbon-fibre roof panel.

SURFACE-TO-AIR PRECISION “The 2014 Corvette Stingray integrates more high-performance aerodynamic features than ever before, many taken directly from Corvette Racing,” says Corvette Chief Engineer Tadge Juechter. “The front grille and radiator flow paths reduce lift, improving vehicle stability at high speeds by keeping the car pressed to the pavement. In addition, functional vents increase track capability by channelling air to the brakes, as well as heat exchangers for the transmission and differential.”

HOOD AIR EXTRACTOR This is no bottom breather. A functional hood extractor directs hot air from the front grille up through the forward-tilted radiator and out of the engine compartment. Each blade is precisely angled for optimal airflow. The result is reduced front-end lift, increased downforce and improved handling at high speeds.

POWERTRAIN COOLING When Stingray is equipped with the available Z51 Performance Package, dual rear quarter panel intake vents guide airflow to cool two separate heat exchangers. One routes air to the transmission cooler. The other cools

the rear differential. Hot air escapes through tailored rear tail light vents and lower-rear fascia outlets. This system was adapted from Corvette Racing to reduce temperatures during high-performance driving.

BRAKE COOLING The available Z51 Performance Package also includes dual brake ducts that transport air from the front grille through the wheelwells to effectively cool front brakes and expel heat. This efficient airflow controls temperature, reduces brake fade and optimizes stopping performance.

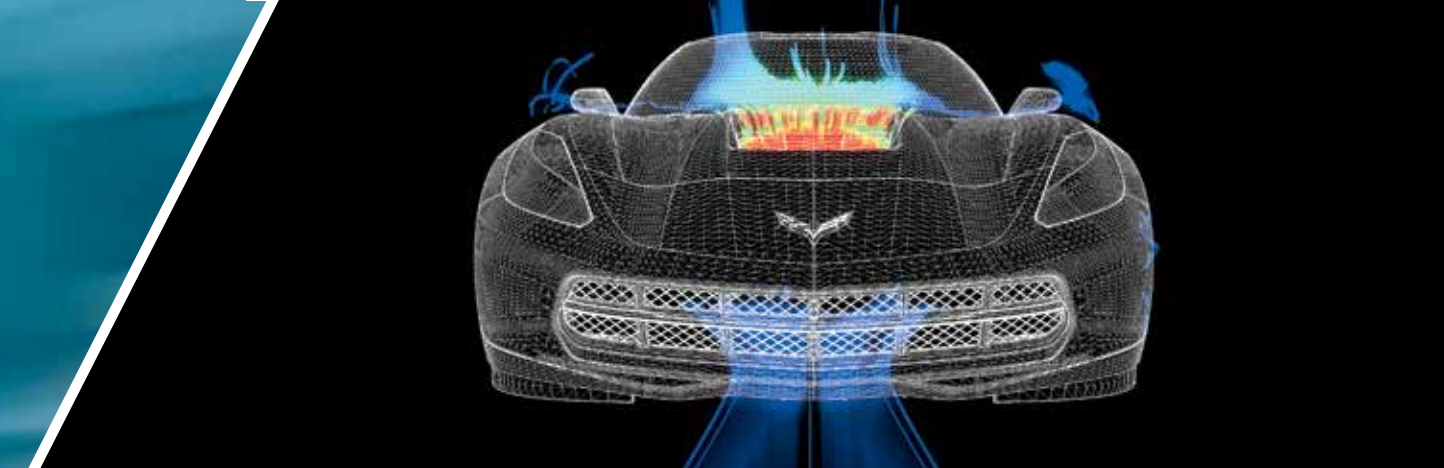

Brake cooling.

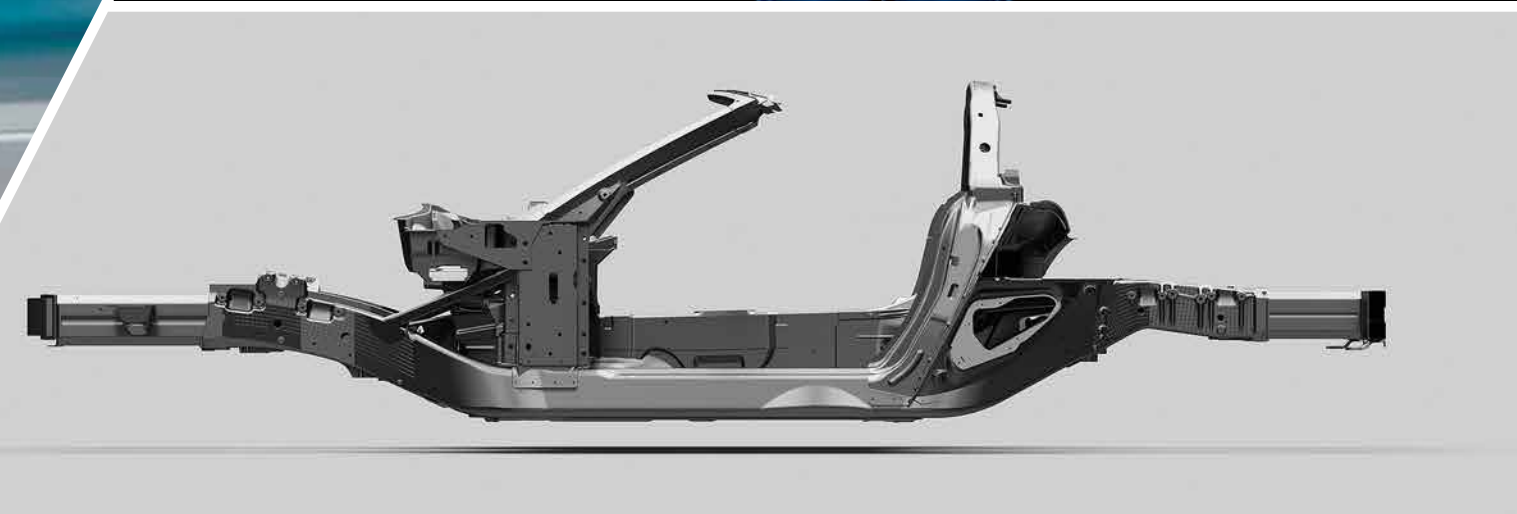

FOR ROADS THAT TWIST, A FRAME THAT DOESN'T.

LIGHTER, MORE RIGID, MORE PRECISE Methodically constructed to be the lightest and stiffest to date, the Stingray aluminum space frame employs an evolutionary approach to precision engineering. One-third the weight of steel, aluminum improves rigidity, which in turn enhances cornering and handling. Lightweight carbon-nano-composite underbody panels bond to aluminum, while strategic use of cool joining processes minimizes

inconsistencies and maximizes bond strength. This revolutionary chassis improves torsional rigidity, reducing noise and elevating performance to an art. **7 SPEEDS, ONE DRIVER** An all-new 7-speed manual transmission complements the LT1 V8 powerhouse that propels Stingray. The rear transaxle location enables a 50/50 vehicle weight balance which optimizes handling. Intelligent sensors anticipate

gear selections and match engine speed for smooth transitions during both upshifts and downshifts. Active Rev Matching, once activated, enhances the driving experience by offering heel-toe downshifting perfection at the touch of a switch. A 6-speed paddle-shift automatic transmission is also available and offers improved shift times in manual mode.

The standard aluminum space frame of the 2014 Corvette Stingray is 45 kg (100 lb.) lighter and 57% more rigid than its steel predecessor.



THIS IS WHY WE RACE.

Corvette Stingray Coupe in Torch Red with available Z51 Performance Package, available split 5-spoke aluminum wheels in Black, available Red brake calipers, available visible carbon-fibre roof panel and available performance exhaust.

¹ 2014 Chevrolet Corvette with 7-speed manual transmission. Fuel consumption ratings based on GM testing in accordance with approved Transport Canada test methods. Your actual fuel consumption may vary. ² Based on GM testing. ³ Summer-only performance tires. Do not use summer-only tires in winter conditions, as it would adversely affect vehicle safety, performance and durability. Use only GM-approved tire and wheel combinations. Unapproved combinations may change the vehicle's performance characteristics. For important tire and wheel information, see your dealer for details.

455 HP STANDARD Completely redesigned, the standard LT1 6.2L V8 engine boasts 455 horsepower and 460 lb.-ft. of torque and offers a highway fuel consumption rating of 6.9 L/100 km¹ – an unprecedented combination. With the available performance exhaust and the available Z51 Performance Package, it can achieve up to 460 horsepower, 465 lb.-ft. of torque and a 0-96 km/h (0-60 mph) time of 3.8 seconds.² Compact engine design lowers the hood line and vehicle centre of gravity. And an available dry-sump oil system delivers oil through high g-force cornering.

POWER TRIO In addition, a trio of innovative technologies rarely seen in elite sports cars

helps achieve this revolutionary pairing of power and fuel efficiency.

DIRECT INJECTION Direct Injection delivers fuel directly into the combustion chamber to achieve maximum thermal and combustion efficiency. More than 6 million hours of computational analysis went into developing the combustion system alone. The result is an impressive 11.5:1 compression ratio that increases torque, power and fuel efficiency.

VARIABLE VALVE TIMING This advanced technology optimizes camshaft timing to improve high-rpm horsepower and low-end torque. An intelligent

position sensor detects engine operating conditions and adjusts the timing of intake and exhaust valves. The result is increased power or torque when needed, enhancing performance and bolstering fuel consumption ratings when combined with Active Fuel Management.[®]

ACTIVE FUEL MANAGEMENT The LT1 6.2L V8 engine with Active Fuel Management is designed for peak power when you need it and fuel efficiency when you don't. This technology deactivates four cylinders when cruising at consistent speeds and offers all eight cylinders with one touch of the accelerator. Active Fuel Management is utilized or disabled at

the driver's discretion. Engine workload is reduced. Fuel efficiency improves. The driver notices performance and nothing else.

Z51 PERFORMANCE PACKAGE Employing actual Corvette Racing technology, an available Z51 Performance Package lets you achieve full track capability. Electronic Limited-Slip Differential and available Magnetic Ride Control[®] promote improved stability, confidence and responsiveness. Performance Traction Management, included with available Magnetic Ride Control, features five settings of torque reduction and brake intervention to allow for more confident

driving on the road or track. Stingray exclusive Michelin[®] Pilot[®] Super Sport ZP summer-only tires³ feature racetrack-born tread compounds and provide superior grip on the road. The Z51 Performance Package also includes larger front and rear wheels, larger front brake rotors, a dry-sump oil system that helps allow for cornering of more than 1 g, optional black spoiler and mirrors, plus premium shocks, springs and stabilizer bars.

MAGNETIC RIDE CONTROL This is the world's fastest-acting suspension. Available only with the Z51 Performance Package, third-generation Magnetic Ride Control is a real-time damping

system that "reads" the road every millisecond. This cutting-edge technology is adjusted using the Driver Mode Selector and delivers more precise body motion control to ensure the highest level of performance possible.

ELECTRONIC LIMITED-SLIP DIFFERENTIAL Torque is optimized when properly divided between the two rear wheels. Included in the available Z51 Performance Package, intelligent Electronic Limited-Slip Differential continuously modulates torque split to improve traction and acceleration out of corners, as well as stability on the highway and steering turn-in responsiveness.



Corvette Stingray Coupe in Laguna Blue Tintcoat (extra-cost colour) with available Z51 Performance Package.

1 Available with Z51 Performance Package.
 2 Included with available Magnetic Ride Control.
 3 When equipped with available 6-speed paddle-shift transmission with automatic mode.
 4 When equipped.

IT KNOWS ROADS YOU'VE NEVER DRIVEN Five distinct, selectable driver modes electronically calibrate up to 12 performance variables to customize your Stingray for any road. And with the available colour Head-Up Display, critical driving data is projected into the driver's line of vision on the windshield.

WEATHER MODE In inclement weather, the vehicle senses and adapts to road conditions, distributing appropriate power to the rear wheels. Tailored traction control and throttle progression promote more confident driving in rain or snow.

ECO MODE To reduce engine workload and conserve fuel, Eco Mode maximizes Active Fuel Management to limit power when travelling at cruising speeds. Fuel efficiency is automatically optimized until aggressive acceleration is called for.

TOUR MODE Tour Mode is the default setting for everyday driving. Engaged systems relax stiffness and enhance comfort for long-distance driving. The customizable gauge cluster can display audio, navigation and phone data.

SPORT MODE Optimized for spirited driving, steering effort and Magnetic Ride Control¹ damping are

stiffened but tempered. The exhaust note becomes more aggressive.

TRACK MODE Designed for legitimate race settings, Track Mode enables launch control to provide maximum off-the-line acceleration. Steering effort and available Magnetic Ride Control¹ damping adjust to provide maximum responsiveness. Available Performance Traction Management² is enabled. Throttle progression optimizes for track performance. Gauge cluster configuration offers a C6.R race-inspired display complete with lap timer.

WITH THE TURN OF A DIAL, EVERYTHING CHANGES The new Driver Mode Selector allows you to easily customize your Stingray driving experience with the turn of just one dial. By selecting one of five distinct driver modes – Weather, Eco, Tour, Sport or Track – Stingray controls the complexity of up to a dozen separate performance variables. Without the hassle of conventional buttons or levers, drivers can automatically adjust steering, throttle progression, traction control and more, just by choosing the right mode for the road.

	WEATHER	ECO	TOUR (DEFAULT)	SPORT	TRACK
Cluster Display	Tour	Tour	Tour	Sport	Track
Throttle Progression	Weather	Normal	Normal	Sport	Sport
Trans Shift Mode ³	Normal	Normal	Normal	Sport	Track
Active Fuel Management	Normal	Eco	Normal	Normal	Normal
Exhaust Mode	Eco	Eco	Tour	Sport	Track
Steering	Comfort	Comfort	Comfort	Sport	Track
Magnetic Ride Control ¹	Tour	Tour	Tour	Sport	Track
Launch Control	N/A	N/A	N/A	N/A	Available
Electronic Limited-slip Differential ⁴	Mode 1	Mode 1	Mode 1	Mode 2	Mode 2-3 Available
Active Handling System	Normal	Normal	Normal	Normal	Comp. Mode Available
Traction Control	Weather	Normal	Normal	Normal	Track
Performance Traction Management ²	Off	Off	Off	Off	Available



Corvette Stingray 3LT interior in Grey with available carbon-fibre interior trim and available Sueded Microfibre-Wrapped Upper Interior Trim Package.

BRIGHTER THAN THE SUN The intuitive instrument cluster bears two ultra-bright 203 mm (8-in.) diagonal high-resolution LED screens – screens so bright they can even be read with the Convertible top down in direct sunlight. The motorized drop-down faceplate beneath the tablet-inspired centre stack touch-screen display reveals a concealed storage area with USB port.¹ And an ingenious colour Head-Up Display (HUD) on 2LT and 3LT complements the dual display, projecting critical data into the driver's line of vision on the windshield.

CHEVROLET MYLINK It's already the quickest, most capable standard Corvette ever made. But Stingray has also evolved to keep you connected and entertained. Using steering wheel-mounted controls, hand gesture recognition and enhanced voice recognition capabilities, the Chevrolet MyLink™² system allows you to make hands-free calls and stream services like Stitcher SmartRadio,³ plus access a broad range of functions including OnStar®⁴ and OnStar Turn-by-Turn Navigation.⁴ Other features include a premium 9-speaker

Bose® sound system on 1LT, or a 10-speaker Bose® Centerpoint® surround sound system on 2LT and 3LT, available 3-D navigation maps, SD card slot, Bluetooth® wireless audio streaming and SiriusXM Satellite Radio™⁵



Available personalized interior plaque.

¹ Not compatible with all devices. ² MyLink functionality varies by model. Full functionality requires compatible Bluetooth and smartphone, and USB connectivity for some devices. Visit MyLink.Chevrolet.ca for more details. ³ Data plan rates apply. ⁴ Visit onstar.ca for coverage map, details and system limitations. Services vary by model and conditions. After the complimentary period, an active OnStar service plan is required. ⁵ Available in 10 Canadian provinces and the 48 contiguous United States. Subscription sold separately after trial period. Visit siriusxm.ca for details.

PERFORMANCE

ENGINE	L71 6.2L V8			
TYPE	90-degree V8, aluminum; continuously Variable Valve Timing			
BORE AND STROKE MM (IN.)	103 x 92 (4.06 x 3.62)			
COMPRESSION RATIO	11.5:1			
HORSEPOWER	455 @ 6000 rpm (460 with performance exhaust)			
TORQUE	460 lb.-ft. @ 4600 rpm (465 with performance exhaust)			
REDLINE	6600 rpm			
0 TO 96 KM/H (0 TO 60 MPH)¹	4 seconds (3.8 seconds with Z51)			
QUARTER MILE¹	12 seconds @ 192 km/h (119 mph) – with Z51			
SKID PAD¹ (MAXIMUM LATERAL ACCELERATION)	1.0 g (1.03 g with Z51)			
BRAKING SYSTEM	Brembo [®] 4-wheel ventilated disc brakes with ABS and Panic Brake Assist			
ROTOR SIZE	320 mm (12.6 in.) ventilated front <p>338 mm (13.3 in.) ventilated rear</p> 345 mm (13.6 in.) slotted front – with Z51 <p>338 mm (13.3 in.) slotted rear – with Z51</p>			
BRAKING DISTANCE¹	96 to 0 km/h (60 to 0 mph) in 34.1 m (112 ft.) <p>96 to 0 km/h (60 to 0 mph) in 32.3 m (106 ft.) – with Z51</p>			
STABILIZER BAR DIAMETER	27 mm <p>28 mm – with Z51</p>			
SHOCK PISTON DIAMETER	35 mm <p>45 mm front/46 mm rear – with Z51</p>			
WHEELS	18" x 8.5" front; 19" x 10" rear <p>19" x 8.5" front; 20" x 10" rear – with Z51</p>			
TIRES – MICHELIN[®] PILOT[®] SUPER SPORT ZP (SUMMER-ONLY²)	P245/40ZR18 front; P285/35ZR19 rear <p>P245/35ZR19 front; P285/30ZR20 rear – with Z51</p>			
TRANSMISSION RATIOS (-:1)	STINGRAY <p>STINGRAY WITH Z51</p>			
GEAR	MANUAL <p>AUTO</p> <p>MANUAL <p>AUTO</p></p>			
1	2.664	4.02	2.966	4.02
2	1.783	2.36	2.066	2.36
3	1.302	1.53	1.426	1.53
4	1.000	1.15	1.000	1.15
5	0.741	0.85	0.709	0.85
6	0.503	0.67	0.567	0.67
7	0.424	–	0.478	–
REVERSE	2.90	3.06	2.90	3.06
AXLE	3.42	2.56	3.42	2.73

SPECIFICATIONS

ESTIMATED FUEL CONSUMPTION³ L/100 KM (MPG)	12.2 (23) city – manual <p>6.9 (41) hwy – manual</p> 13.3 (21) city – auto <p>7.1 (40) hwy – auto</p>
WHEELBASE	2710 mm (106.7 in.)
OVERALL LENGTH	4493 mm (176.9 in.)
OVERALL WIDTH	1877 mm (73.9 in.)
TRACK	1600 mm (63.0 in.) – front <p>1567 mm (61.7 in.) – rear</p>
HEIGHT	1240 mm (48.8 in.) – Coupe <p>1243 mm (48.9 in.) – Convertible</p>
HEADROOM	963 mm (37.9 in.)
LEGROOM	1092 mm (43.0 in.)
SHOULDER ROOM	1402 mm (55.2 in.)
HIP ROOM	1364 mm (53.7 in.)
LUGGAGE COMPARTMENT CAPACITY	425 L (15.0 cu. ft.) – Coupe <p>283 L (10.0 cu. ft.) – Convertible</p>
FUEL TANK CAPACITY	70 L (15.4 imp. gal.)
ENGINE OIL CAPACITY	6.6 L (5.8 imp. qt.) <p>9.2 L (8.1 imp. qt.) – with Z51</p>
STEERING WHEEL DIAMETER	360 mm (14.2 in.)
STEERING ROTATION: LOCK-TO-LOCK	2.57 turns
TURNING CIRCLE: CURB-TO-CURB	11.5 m (37.7 ft.)
CURB WEIGHT	1496 kg (3298 lb.) – Coupe <p>1525 kg (3362 lb.) – Convertible</p>
DRY WEIGHT	1433 kg (3160 lb.) – Coupe
POWER-TO-WEIGHT	3.29 kg (7.25 lb.) curb weight/hp – Coupe <p>3.35 kg (7.39 lb.) curb weight/hp – Convertible</p> 3.25 kg (7.17 lb.) curb weight/hp – Coupe with performance exhaust <p>3.32 kg (7.31 lb.) curb weight/hp – Convertible with performance exhaust</p>
WEIGHT DISTRIBUTION	50/50
DRAG COEFFICIENT	0.29 cd

STANDARD AND INCREMENTAL EQUIPMENT

CORVETTE STINGRAY 1LT	
LT1 6.2L V8 engine with Direct Injection, Variable Valve Timing and Active Fuel Management	
Engine oil cooler	
Oil life monitoring system	
Aluminized stainless steel exhaust with 3 in. polished stainless steel tips	
7-speed manual transmission with Active Rev Matching	
Brembo 4-wheel ventilated disc brakes with ABS and Panic Brake Assist	
Dark Grey Metallic-painted brake calipers	
Active Handling System and traction control	
Speed-sensitive electric variable-ratio power rack-and-pinion steering	
4-wheel independent sport suspension	
Aluminum frame structure	
Xenon [®] High-Intensity Discharge (HID) headlights and upper LED daytime running lights with automatic light control	
Carbon-fibre hood with rear opening for engine access	
Carbon-fibre removable roof panel, painted body-colour (Coupe)	
Full power top with remote activation, includes glass rear window with integral defroster (Convertible)	
Heated, power exterior mirrors	
Capless fuelling	
Run-flat summer-only performance tires ²	
5-spoke Silver-painted aluminum wheels	
Rear vision camera	
Keyless access system with push-button start	
Frontal and side-impact airbags ⁴ for driver and passenger with Passenger Sensing System	
Driver Information Centre with reconfigurable high-resolution 203 mm (8-in.) diagonal colour display; includes trip/fuel information, vehicle information, vehicle settings and driver mode settings for Tour, Sport and Track modes	
Tire pressure monitoring system	
Driver Mode Selector with 5 modes	
Dual-zone automatic climate controls with exterior temperature display, air filtration and pollen filter	
Power windows with express-down/-up feature and programmable door locks with lock-out protection	
Power tilt and telescopic adjustable steering column	
Cruise control	
3-spoke leather-wrapped steering wheel with Bluetooth, [®] cruise, audio system and Driver Information Centre controls	
Leather-wrapped gearshift	
Lighting: Courtesy, cargo and glovebox	
Retained accessory power	
Frameless interior rear-view mirror	
Storage: Locking glovebox, centre console and two rear compartments with covers	
Illuminated visor vanity mirrors for driver and passenger	
GT bucket seats with power 8-way driver- and passenger-seat adjusters	
Perforated Mulan leather seating surfaces	

CORVETTE STINGRAY 1LT (CONTINUED)	
Chevrolet MyLink [®] Radio infotainment system with 203 mm (8-in.) diagonal high-resolution colour touch-screen display with motorized power up/down and hidden storage, smartphone integration, Bluetooth wireless audio streaming, Gracenote [®] database and natural voice recognition	
9-speaker premium Bose [®] audio system	
SiriusXM Satellite Radio ⁶	
USB port ⁷	
Bluetooth hands-free phone connectivity and wireless audio streaming	
OnStar with 6 months of the Directions & Connections Plan featuring Turn-by-Turn Navigation ⁸ and OnStar RemoteLink. ^{9,9}	

CORVETTE STINGRAY 2LT

In addition to or replacing 1LT features, 2LT includes:

Heated, power exterior mirrors with driver-side auto-dimming feature	
Advanced theft-deterrent system	
Colour-keyed console and door armrests	
Colour Head-Up Display (HUD) with readouts for Tour mode, Sport mode, Timing mode and Track mode with g-meter, vehicle speed and engine rpm	
Frameless auto-dimming interior rear-view mirror	
Heated and ventilated bucket seats with power bolster and lumbar adjusters	
Driver-side 2-position Memory Package	
Luggage compartment convenience net	
Luggage compartment shade (Coupe)	
Universal home remote 3-channel programmable transmitter	
10-speaker Bose [®] Centerpoint [®] surround sound system.	

CORVETTE STINGRAY 3LT

In addition to or replacing 2LT features, 3LT includes:

Chevrolet MyLink [®] Radio with Navigation, including 203 mm (8-in.) diagonal high-resolution colour touch-screen display with motorized power up/down and hidden storage, smartphone integration, Bluetooth wireless audio streaming, Gracenote database, natural voice recognition and enhanced GPS navigation system with 3 trial months of SiriusXM NavTraffic ⁶	
Leather-wrapped and colour-keyed instrument panel, doors and console	
Napa leather seating surfaces.	

AVAILABLE FEATURES

	1LT	2LT	3LT
AVAILABLE EQUIPMENT			
6-speed paddle-shift transmission with automatic mode and remote vehicle starter system; includes auxiliary transmission oil cooler	<input type="checkbox"/>	<input type="checkbox"/>	<input type="checkbox"/>
Performance exhaust with 4" polished stainless steel tips and aggressive exhaust sound; increases horsepower to 460	<input type="checkbox"/>	<input type="checkbox"/>	<input type="checkbox"/>
Magnetic Ride Control with Performance Traction Management	<input type="checkbox"/> ¹⁰	<input type="checkbox"/> ¹⁰	<input type="checkbox"/> ¹⁰
Battery Maintainer Package	<input type="checkbox"/>	<input type="checkbox"/>	<input type="checkbox"/>
Carbon Flash-painted rear spoiler and exterior mirrors	<input type="checkbox"/> ¹⁰	<input type="checkbox"/> ¹⁰	<input type="checkbox"/> ¹⁰
Painted brake calipers in Red or Yellow	<input type="checkbox"/>	<input type="checkbox"/>	<input type="checkbox"/>
Custom-made interior plaque personalized with your name	<input type="checkbox"/>	<input type="checkbox"/>	<input type="checkbox"/>
GT bucket seats with sueded microfibre seat inserts	–	<input type="checkbox"/>	<input type="checkbox"/>
Competition Sport bucket seats with leather seat inserts	–	<input type="checkbox"/>	<input type="checkbox"/>
Competition Sport bucket seats with sueded microfibre seat inserts, includes sueded microfibre wrap for steering wheel and gearshift	<input type="checkbox"/>	<input type="checkbox"/>	<input type="checkbox"/>
Sueded Microfibre-Wrapped Upper Interior Trim Package: Sueded microfibre headliner, visors, trim above windshield and rear window cover, A-pillar trim and area around quarter windows	–	–	<input type="checkbox"/>
Carbon-fibre trim on the instrument panel	–	<input type="checkbox"/>	<input type="checkbox"/>
Chevrolet MyLink [®] Radio with Navigation	<input type="checkbox"/>	<input type="checkbox"/>	■
WHEELS¹¹			
5-spoke machined-face aluminum	<input type="checkbox"/>	<input type="checkbox"/>	<input type="checkbox"/>
5-spoke aluminum, chrome	<input type="checkbox"/>	<input type="checkbox"/>	<input type="checkbox"/>
Z51 split 5-spoke aluminum, Black	<input type="checkbox"/> ¹⁰	<input type="checkbox"/> ¹⁰	<input type="checkbox"/> ¹⁰
Z51 split 5-spoke aluminum, chrome	<input type="checkbox"/> ¹⁰	<input type="checkbox"/> ¹⁰	<input type="checkbox"/> ¹⁰

■ STANDARD AVAILABLE – NOT AVAILABLE

	1LT	2LT	3LT
Z51 PERFORMANCE PACKAGE			
Performance manual transmission gear ratios			
Electronic limited-slip differential			
Differential and transmission cooling systems			
Heavy-duty engine cooling			
Dry-sump oil system			
Specific shocks, springs and stabilizer bars			
Larger front brake rotors with Black calipers			
Slotted brake rotors			
Specific Michelin Pilot Super Sport ZP summer-only tires ² (unique and aggressively tuned to provide outstanding handling, grip and road-holding capability)			
Larger 19" x 8.5" front and 20" x 10" rear split 5-spoke Silver-painted aluminum wheels			
Aero Package that reduces lift for high-speed stability	<input type="checkbox"/>	<input type="checkbox"/>	<input type="checkbox"/>
COUPE REMOVABLE ROOF PANEL OPTIONS			
One-piece transparent roof panel	<input type="checkbox"/>	<input type="checkbox"/>	<input type="checkbox"/>
One-piece visible carbon-fibre roof panel with body-colour surround	<input type="checkbox"/>	<input type="checkbox"/>	<input type="checkbox"/>
Body-colour Dual Roof Package: Body-colour roof panel and transparent roof panel	<input type="checkbox"/>	<input type="checkbox"/>	<input type="checkbox"/>
Carbon-fibre Dual Roof Package: Visible carbon-fibre roof panel with body-colour surround and transparent roof panel	<input type="checkbox"/>	<input type="checkbox"/>	<input type="checkbox"/>
GRAPHICS			
Hood Stinger Stripe (Carbon Flash or Cyber Grey)	<input type="checkbox"/>	<input type="checkbox"/>	<input type="checkbox"/>
Full-length Dual Racing Stripe Package (Blade Silver, Carbon Flash, Crystal Red, Cyber Grey or Inferno Orange)	<input type="checkbox"/>	<input type="checkbox"/>	<input type="checkbox"/>

^[1] Based on GM testing.
^[2] Do not use summer-only tires in winter conditions, as it would adversely affect vehicle safety, performance and durability. Use only GM-approved tire and wheel combinations. Unapproved combinations may change the vehicle's performance characteristics. For important tire and wheel information, see your dealer for details.
^[3] Fuel consumption ratings based on GM testing in accordance with Transport Canada test methods. Your actual fuel consumption may vary.
^[4] Always use safety belts and the correct restraint for your child's age and size. Even in vehicles equipped with the Passenger Sensing System, children are safer when properly secured in a rear seat in the appropriate infant, child or booster seat. Never place a rear-facing infant restraint in the front seat of any vehicle equipped with a passenger airbag. See the Owner's Manual and the child safety seat instructions for more safety information.
^[5] MyLink functionality varies by model. Full functionality requires compatible Bluetooth and smartphone, and USB connectivity for some devices. Visit MyLink.Chevrolet.ca for more details.
^[6] Available in 10 Canadian provinces and the 48 contiguous United States. Subscription sold separately after trial period. Visit siriusxm.ca for details.
^[7] Not compatible with all devices.
^[8] Visit onstar.ca for coverage map, details and system limitations. Services vary by model and conditions. OnStar acts as a link to existing emergency service providers. Not all vehicles may transmit all crash data. After the complimentary trial period, an active OnStar service plan is required.
^[9] Available on select Apple, Android, BlackBerry and Windows devices. Services vary by device, vehicle and conditions. Requires active OnStar service plan.
^[10] Requires available Z51 Performance Package.
^[11] These wheels are paired with summer-only tires. Do not use summer-only tires in winter conditions, as it would adversely affect vehicle safety, performance and durability. Use only GM-approved tire and wheel combinations. Unapproved combinations may change the vehicle's performance characteristics. For important tire and wheel information, see your dealer for details.

INTERIORS (SELECT EXAMPLES SHOWN)



Black Leather (1LT)

Adrenaline Red Leather (1LT)

Grey Leather (1LT)

Black Leather/Sueded Microfibre Inserts with Available Competition Sport Seats (1LT)



Black Leather (2LT)

Adrenaline Red Leather (2LT)

Grey Leather (2LT)

Kalahari Leather (2LT)



Brownstone Leather (3LT)

Adrenaline Red Leather (3LT)

Grey Leather/Sueded Microfibre Inserts with Available Competition Sport Seats (3LT)

Kalahari Leather/Sueded Microfibre Inserts with Available Competition Sport Seats (3LT)

COLOURS (SHOWN WITH AVAILABLE Z51 PERFORMANCE PACKAGE)



G7H - LAGUNA BLUE TINTCOAT¹



G7J - LIME ROCK GREEN METALLIC¹



G8A - VELOCITY YELLOW TINTCOAT¹



G8G - ARCTIC WHITE



GAN - BLADE SILVER METALLIC



G8A - BLACK



G8E - CRYSTAL RED TINTCOAT¹



GBV - CYBER GREY METALLIC



GKZ - TORCH RED



GXH - NIGHT RACE BLUE METALLIC

RECOMMENDED COLOUR COMBINATIONS

EXTERIOR COLOURS	INTERIOR COLOURS (1LT, 2LT, 3LT)				
	CONVERTIBLE TOP COLOURS ■ 41T - BLACK ■ 21T - KALAHARI ■ 37T - GREY ■ 34T - BLUE				
	BLACK 1LT, 2LT, 3LT	GREY 1LT, 2LT, 3LT	ADRENALINE RED 1LT, 2LT, 3LT	KALAHARI 2LT, 3LT	BROWNSTONE 3LT
G7H - Laguna Blue Tintcoat ¹	■ ■ ■	■ ■	-	■ ■	■ ■
G7J - Lime Rock Green Metallic ¹	■ ■ ■	■	-	■ ■	■ ■
G8A - Velocity Yellow Tintcoat ¹	■ ■ ■	■ ■	-	■	■
G8G - Arctic White	■ ■ ■ ■	■ ■ ■	■	■ ■ ■	■ ■ ■
GAN - Blade Silver Metallic	■ ■ ■ ■	■ ■ ■	■	■ ■	■ ■
G8A - Black	■ ■ ■ ■	■ ■ ■	■	■ ■	■ ■
G8E - Crystal Red Tintcoat ¹	■ ■ ■	■ ■	■	■ ■	■ ■
GBV - Cyber Grey Metallic	■ ■ ■ ■	■ ■ ■	■	■ ■ ■	■ ■ ■
GKZ - Torch Red	■ ■ ■	■ ■	■	■ ■	■ ■
GXH - Night Race Blue Metallic	■ ■ ■ ■	■ ■ ■	-	■ ■ ■	■ ■ ■

¹ Extra-cost colour.

CONVERTIBLE TOP COLOURS



41T - Black



21T - Kalahari



37T - Grey



34T - Blue



Black calipers shown with Brembo® slotted brakes for Stingray with available Z51 Performance Package.



Available Red calipers shown with Brembo slotted brakes for Stingray with available Z51 Performance Package.



Available Yellow calipers shown with Brembo slotted brakes for Stingray with available Z51 Performance Package.

¹ These wheels are paired with summer-only tires. Do not use summer-only tires in winter conditions, as it would adversely affect vehicle safety, performance and durability. Use only GM-approved tire and wheel combinations. Unapproved combinations may change the vehicle's performance characteristics. For important tire and wheel information, see your dealer for details. ² Do not use summer-only tires in winter conditions, as it would adversely affect vehicle safety, performance and durability. Use only GM-approved tire and wheel combinations. Unapproved combinations may change the vehicle's performance characteristics. For important tire and wheel information, see your dealer for details.



01 Available 5-spoke machined-face aluminum wheel (RQ1)¹

04 Standard with Z51 Performance Package, split 5-spoke Sterling Silver-painted aluminum wheel¹

07 Available Torque Directional accessory wheel¹ in Silver.

02 Standard 5-spoke Silver-painted aluminum wheel¹

05 Available with Z51 Performance Package, split 5-spoke aluminum wheel¹ in Black (Q7T).

08 Available Torque Directional accessory wheel¹ in chrome.

03 Available 5-spoke aluminum wheel¹ in chrome (QX3).

06 Available with Z51 Performance Package, split 5-spoke aluminum wheel¹ in chrome (Q7E).



Corvette Stingray Coupe in Cyber Grey Metallic with available Z51 Performance Package featuring Michelin® Pilot® Super Sport ZP summer-only tires²

OTHER OWNERSHIP PRIVILEGES AND PROGRAMS:**

- GM Protection Plan (GMPP) – the only extended service plan backed by the resources and commitment of General Motors, GMPP may be purchased at the time of sale or subsequently during the New Vehicle Limited Warranty period
 - GM Goodwrench Service – with GM-certified technicians and GM-approved parts, nobody knows your Chevrolet vehicle better
 - Chevrolet Owner Centre – as an owner, take advantage of the Chevrolet Owner Centre. This online owner's destination gives you access to contests, current offers, and the latest driving and maintenance tips. Find out more at chevroletowner.ca
- ** Conditions and limitations apply.

TO HELP YOU PURCHASE OR LEASE A NEW VEHICLE:

- Purchase Financing and Leasing – on-the-spot financing; see dealer for full details! † Subject to eligibility.

INFORMATION RESOURCES:

- You can find more information about these programs from your Chevrolet dealer, or at these information centres:
- The GM website at gm.ca
 - The GM Customer Care Centre at 1-800-GM-DRIVE (1-800-463-7483 or 1-800-263-3830 for TDD users).

A WORD ABOUT THIS BROCHURE

Some of the equipment shown or described throughout this brochure may be available at extra cost. We have tried to make this brochure comprehensive and factual. We reserve the right, however, to make changes at any time, without notice, in prices, colours, materials, equipment, specifications, models and availability. Specifications, dimensions, measurements, ratings and other numbers in this brochure and other printed materials provided at the dealership or affixed to vehicles are approximates based upon design and engineering drawings and prototypes and laboratory tests. Your vehicle may differ due to variations in manufacture and equipment. Since some information may have been adapted since the time of the printing, please check with your Chevrolet dealer for complete details. General Motors of Canada Limited reserves the right to lengthen or shorten the model year for any product, for any reason, or to start and end model years at different times.

A WORD ABOUT ASSEMBLY

Chevrolet vehicles are equipped with engines and components produced and assembled by different operating units of General Motors, its subsidiaries and suppliers, and these engines and components may change or be obtained from different sources from time to time. All such engines and components are approved for use in Chevrolet vehicles. Certain equipment ordered may be unavailable at the time of assembly and we suggest that you verify that your vehicle includes the equipment you ordered, or if there are changes, that they are acceptable to you.

TRADEMARKS

The marks appearing in this brochure including, but not limited to, General Motors, GM, Chevrolet, the Chevrolet emblem, Corvette and their respective logos, emblems, slogans and vehicle model names and body designs; and other marks such as Active Fuel Management, Find New Roads, Magnetic Ride Control and MyLink are trademarks of General Motors LLC and/or General Motors of Canada Limited, its subsidiaries, affiliates or licensors. ©Copyright 2013 General Motors of Canada Limited. All rights reserved. OnStar, the OnStar emblem and OnStar RemoteLink are registered trademarks of OnStar, LLC. Apple is a trademark of Apple Inc. registered in the U.S. and other countries. BlackBerry is a registered trademark of Research In Motion Limited. Bluetooth is a registered trademark of Bluetooth SIG, Inc. Bose and Centerpoint are registered trademarks of the Bose Corporation. Brembo is a registered trademark of Brembo S.p.A. Facebook is a registered trademark of Facebook Inc. Gracenote is a registered trademark of Gracenote, Inc. Michelin and Pilot are registered trademarks or trademarks of Michelin North America, Inc. SiriusXM, the SiriusXM logo, channel names and logos are trademarks of SiriusXM Radio Inc. Stitcher and Stitcher SmartRadio are registered trademarks of Stitcher SmartRadio Inc. Twitter is a trademark of Twitter Inc. YouTube is a registered trademark and Android is a trademark of Google Inc.

COPYRIGHT

©Copyright 2013 General Motors of Canada Limited. All rights reserved. All text, images, graphics and other materials in this brochure are subject to the copyright and other intellectual property rights of General Motors LLC and/or General Motors of Canada Limited. These materials may not be reproduced, distributed or modified without the express written permission of General Motors LLC and/or General Motors of Canada Limited. Printed in Canada, November 2013

