

# IONIQ

2017





# What is IONIQ?

IONIQ is the latest vehicle innovation from Hyundai. We believe that hybrid and electric vehicles should be exciting and fun to drive — that is the IONIQ philosophy. The all-new IONIQ is the world's first vehicle to feature three electrified powertrain options — hybrid, electric and electric plus — built around a SUPERSTRUCTURE™ designed from the ground up to offer an exceptional driving experience and enhanced safety.

IONIQ shows our commitment to developing advanced, environmentally conscious technologies that help reduce automotive pollution. Our vision is to lead the industry by developing advanced propulsion vehicles that are fun to drive, have great style and that benefit the environment.

At Hyundai we strive to develop and design vehicles to enhance people's everyday lives. By challenging the standard of design and workmanship, we continue to rethink the future of mobility.



# The power of choice

## Three engaging driving experiences

It is easy to decide which IONIQ best complements your lifestyle; it just depends on how often you drive and your driving style. Whichever you choose, every IONIQ is engineered to deliver a rewarding and engaging drive to suit your lifestyle.



2017 **IONIQ** electric

Charge from home or work. Never stop for gas. On a single charge, the IONIQ electric model offers up to a 200-kilometre range of emission-free driving. The 88 kW electric motor's torque-rich performance is powered by the super-efficient 28 kWh lithium-ion polymer battery. The battery is located low in the IONIQ's purpose-built chassis, which also lowers its centre of gravity, essential for a rewarding and engaging drive.



2017 **IONIQ** hybrid

Driving fun with lower emissions. The IONIQ hybrid combines an efficient 1.6L gasoline engine with a powerful 32 kW electric motor for impressive performance and fuel efficiency. For unmatched responsiveness, it also features a class-exclusive Dual Clutch Transmission\*. Together, these elements give you the fuel economy you want from a hybrid, with a driving experience that's more engaging than you thought possible.



2018 **IONIQ** electric plus

Electric when you want it. Gas when you need it. The IONIQ electric plus offers the best of both worlds, with a larger lithium-ion polymer battery (compared to hybrid model) to provide over 40 kilometres (estimated only) of all-electric, emission-free driving.

ARRIVING LATE 2017

# Advanced aerodynamics

With an industry-leading drag coefficient of just 0.24, the IONIQ is one of the most aerodynamic vehicles on the market. Streamlined contours have been designed to harness airflow and minimize air resistance. The signature hexagonal grille features computer-controlled air shutters that open and close automatically to optimize aerodynamics (hybrid model), while air intakes beside the signature LED daytime running lights help reduce turbulence around the front wheels. All of these elements and more combine to create a stunningly attractive design that delivers best-in-class fuel efficiency\*.

Aerodynamic  $C_d$  0.24:

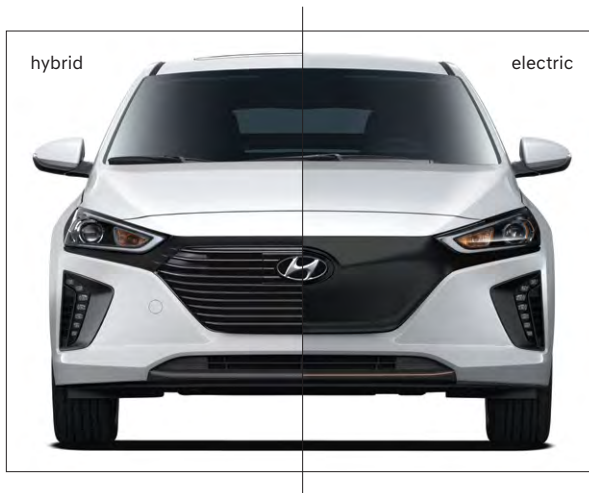
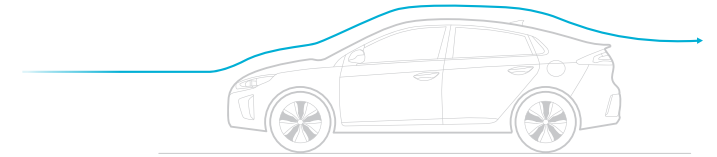

## Aerodynamic grille

The signature hexagonal grille on the IONIQ hybrid features active air shutters that open and close to improve aerodynamics. The IONIQ electric conveys a unique front perspective. Without the need for extensive powertrain cooling, the grille is a sleek, smooth surface.



## LED lighting

Stylish tail lights feature available LED technology to deliver maximum illumination while drawing a minimal amount of electricity, which improves efficiency.



## Rear bumper

The two-tone bumper features a black insert to add a sporty touch and provide continuity with the front end design.







# Immerse yourself

The spacious interior of the IONIQ is charged with distinct design cues. This becomes evident in the strong horizontal contouring of the dashboard and unique white, or blue (hybrid model), or copper-coloured (electric model) accents throughout the cabin. Thanks to the innovative design of the lithium-ion polymer battery and purpose-built chassis, you don't have to choose between efficiency and space. Enjoy maximum versatility with expansive cargo space and 60/40 split fold seats. And you won't have to compromise on features we know matter most in Canada — this is why heated front seats are standard, and a heated steering wheel and rear heated seats are available for those who like extra warmth.



Hybrid Limited with Technology model shown

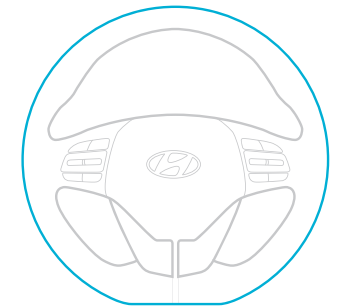

D-cut steering wheel,  
available heated

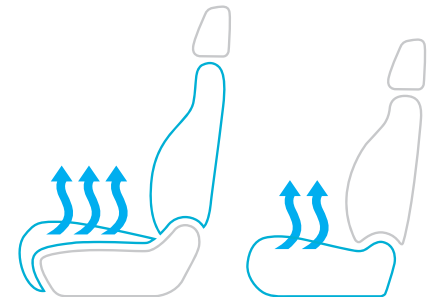

Standard heated front seats  
Available heated rear seats

# Simply stay connected



The standard 7.0" touch-screen display is the connectivity hub of the IONIQ. Apple CarPlay™ and Android Auto™ put the power of your favourite smartphone apps right on the touch-screen display. You can access directions, make calls and send and receive text messages while keeping your hands on the wheel and your eyes focused on the road. You can also listen to your favourite playlist through the available Infinity® sound system. The available wireless charging feature even lets you recharge your compatible smartphone without connecting cables▲.

- 01 Available 8.0" touch-screen navigation system
- 02 Available wireless charging pad





- 03 Standard Apple CarPlay™
- 04 Available Infinity® audio system with 8 speakers



# Hybrid powertrain

The IONIQ hybrid is powered by a specially developed powertrain that offers the perfect blend of power and efficiency. It can run on a gas engine, an electric motor, or both. Travel over 1,000 kilometres on a single tank of gas<sup>†</sup>.

BEST-IN-CLASS<sup>†</sup>  
4.1L/100km  
combined fuel  
efficiency<sup>†\*</sup>

## Hybrid energy flow

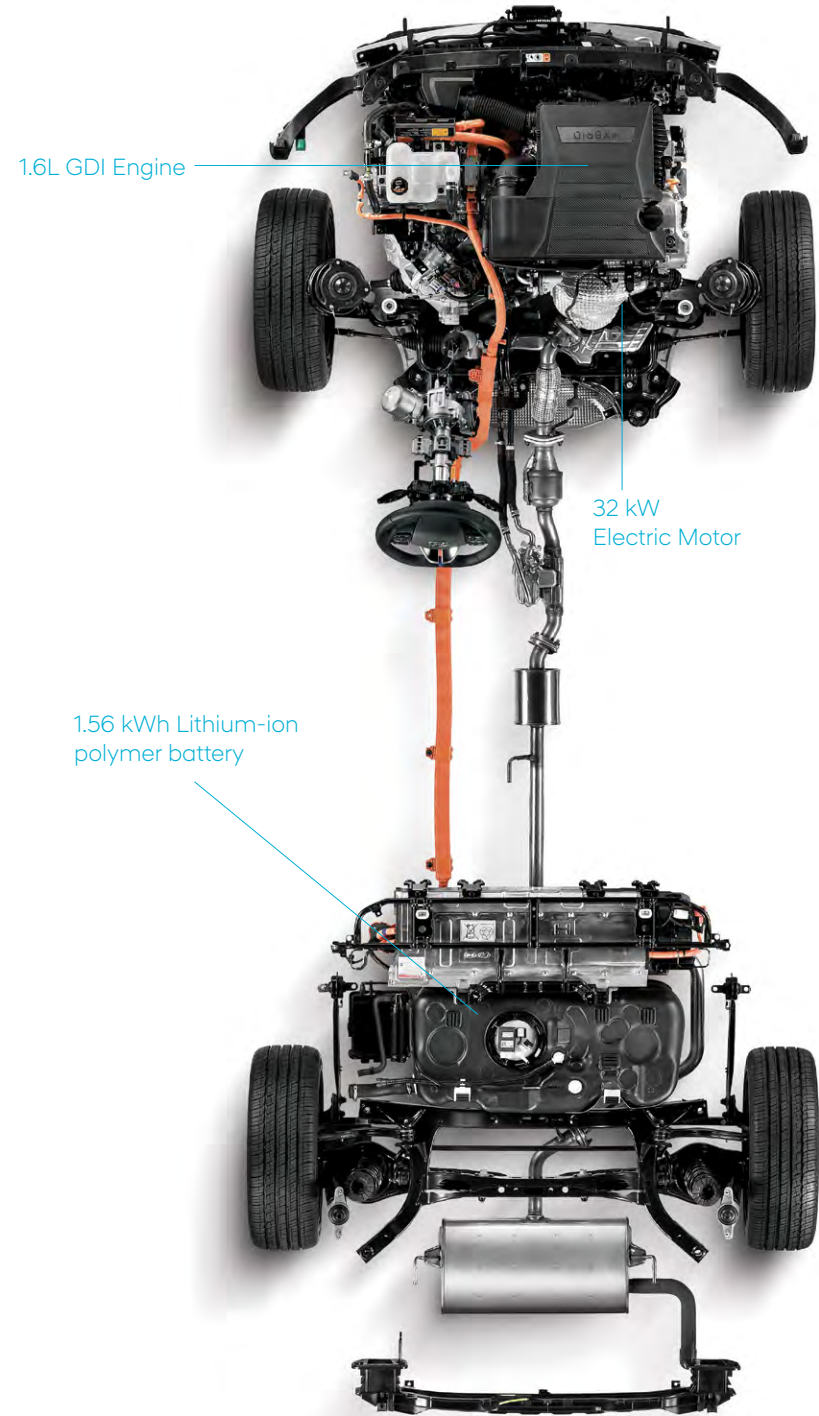
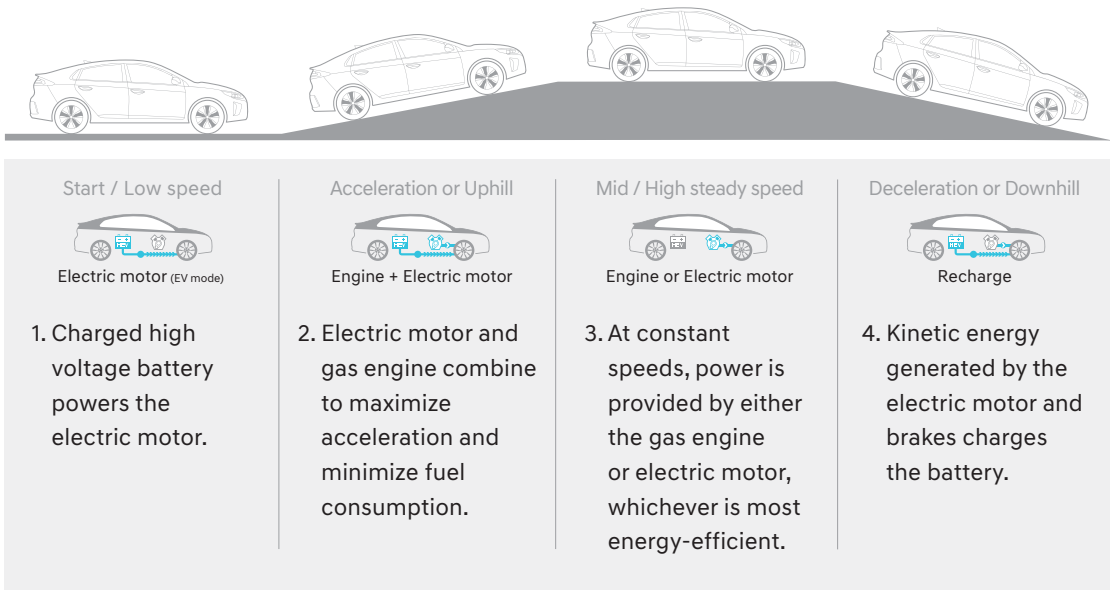

# Electric powertrain

The components of the electric powertrain have been engineered to provide excellent driving characteristics and a practical everyday driving range. IONIQ electric combines the high power density of a compact, lightweight, lithium-ion polymer battery with a high-power electric motor and high-efficiency reduction gear. You can travel up to 200 kilometres with a full charge<sup>††</sup>.

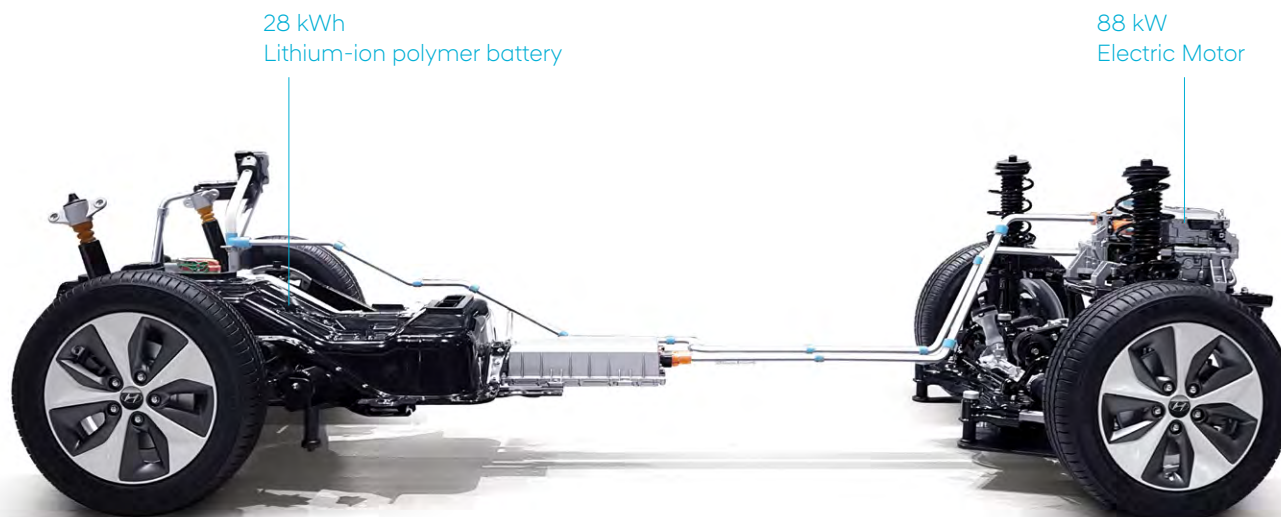

The IONIQ electric can be charged at home, or while you're out and about. The estimated driving range at any time is clearly displayed on the supervision display to keep you informed and you can use the available navigation system to map out charging stations within the vicinity of your electric range.

	Level 1	Level 2	Level 3
<b>Type</b>	Standard household outlet	Available household outlet/public	Public
<b>Voltage</b>	120V	240V	450V
<b>Charging time</b>	24 hours	4.5 hours	35 minutes

Level 2 and Level 3 charging cables not included. All charging times are approximate.





# Next level innovation

Hybrid and electric vehicles should have the dynamic ride and handling characteristics that make driving a pleasure. That's the IONIQ philosophy. The industry-leading technology with which we have engineered the IONIQ delivers a one-of-a-kind experience. With IONIQ you get an extremely engaging driving experience, plus an efficient commuter. For example, thanks to the innovative design of the battery and IONIQ's purpose-built chassis we are able to mount it under the rear seats. This gives the IONIQ an exceptionally low centre of gravity that greatly enhances agility and helps make IONIQ so much fun to drive. It also means the IONIQ offers expansive trunk space for maximum versatility.



## Class-exclusive 6-Speed Dual Clutch Transmission\*

The 6-speed Dual Clutch Transmission (hybrid model) improves efficiency and provides instant engine feedback for unparalleled responsiveness.



28 kWh battery shown

## Class-exclusive Lithium-ion polymer battery<sup>o</sup>

All IONIQ models feature this state-of-the-art battery technology that's smaller, lighter, more energy dense, more thermally efficient, more durable, and easier to package than the Nickel-Metal Hydride or Lithium-ion options found in competitors.



## Engineered to engage

The drive modes have been engineered to give you an electrifying and engaging driving experience. Eco mode provides the efficiency you'd expect, while everything changes in Sport mode. The powertrain uses the electric power to boost torque levels for a totally different feeling. The digital instrument cluster even changes appearance and colour when a different drive mode is selected.



# Anatomy of the IONIQ

At the core of the IONIQ is the SUPERSTRUCTURE™, a rigid but lightweight body made of our Advanced High Strength Steel to deliver superior benefits in handling, cabin quietness and occupant safety.

## SUPERHANDLING

The rigid composition of the SUPERSTRUCTURE™ enables more precise tuning of key suspension components. This means that the IONIQ is engineered to deliver agile handling and confidence at higher speeds.

## SUPERQUIET

Steel rigidity and extended application of soundproofing materials both help to keep outside noises where they belong. Whether you are navigating dense city traffic or cruising Canada's wide-open highways, enjoy greatly reduced noise and vibration levels.

## SUPERSAFETY

The exceptional stiffness and strength of the SUPERSTRUCTURE™ combined with the extended application of structural adhesives to reinforce critical areas helps provide added protection to occupants. In the event of a collision, the SUPERSTRUCTURE™ will absorb harmful energy and redirect it away from the passenger compartment.



# Intelligent safety

In addition to the SUPERSTRUCTURE™ and seven standard airbags, you and your passengers will be protected by a comprehensive list of available active driver assistance technologies.



## Autonomous Emergency Braking with Pedestrian Detection<sup>1</sup>

This available safety innovation uses a forward camera and radar sensors to detect rapid closing speeds to the vehicle ahead or pedestrians in your path. If a potential forward collision is detected, warning notifications alert the driver. The system can provide full braking assistance to help avoid an imminent collision at speeds between 8 and 80 kilometres per hour (vehicle detection) or 8 and 69 kilometres per hour (pedestrian detection).



## Lane Departure Warning System<sup>2</sup>

Drift outside your lane without signalling and this available system is designed to inform you with audible and visual cues.



## Blind Spot Detection with Lane Change Assist<sup>3</sup>

To help you change lanes with confidence, the available Blind Spot Detection uses radar to detect when a vehicle is in the driver's blind spot. It works in conjunction with Lane Change Assist, which measures the approaching speed of the vehicle in the lane next to you to help determine if a lane change is safe.





Standard seven  
airbags

Available Adaptive  
Cruise Control

Standard rearview  
camera

Available Rear  
Cross-Traffic Alert

Available Rear Parking  
Assist Sensors  
(hybrid model only)





## Accessories



### Premium Block Heater

Engineered for your Hyundai, a block heater will help ensure fast starts and reduce engine wear in extreme weather (hybrid model only).



### Premium All-Weather Floor Liners

Premium all-weather floor liners were designed to cover the interior carpet providing maximum protection against the elements that other mats cannot offer. Their unique and durable design features a non-slip surface for added comfort and a long-lasting premium look. Remove carpet mats prior to installation.



### Trunk Lip Protector

Help protect the paintwork on your rear bumper from scuffs and scrapes when loading and unloading cargo.



### Wheel Lock Nuts

Help protect your valuable wheels and tires from theft with a set of Hyundai wheel lock nuts.

# The choice is yours

Complete the IONIQ's sleek exterior with the colour of your choice.

H - Hybrid model  
E - Electric model

## Exterior colours

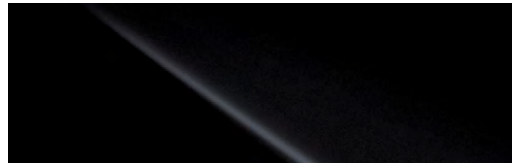

Phantom black H E



Platinum silver H E



Polar white H E



Marina blue H E

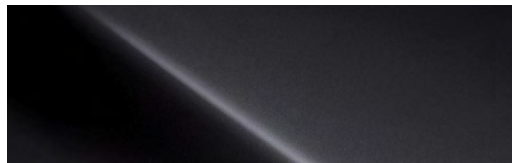

Iron grey H



Aurora silver H

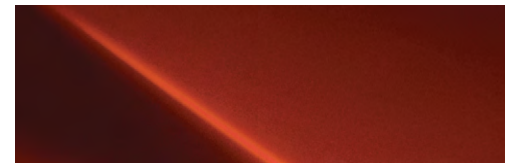

Phoenix orange\* H

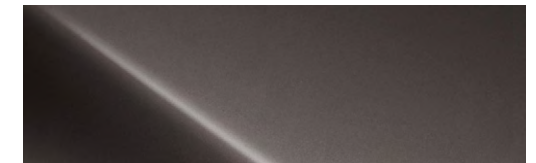

Café brown\* H

## Interior colours

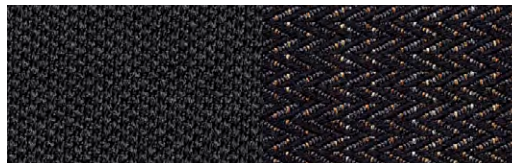

Black cloth H E

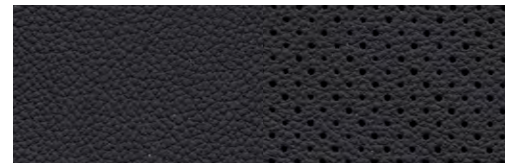

Black leather H E

## Interior colour accents



Blue accents  
Hybrid - Blue and SE models

H



White accents  
Hybrid - Limited models

H



Copper-coloured accents  
Electric - all models

E

## Wheels



H  
Standard  
15" eco  
alloy wheels



H  
Available  
17" eco  
alloy wheels

E  
16" eco  
alloy wheels  
Silver finish

E  
16" eco  
alloy wheels  
White finish  
(with Polar white exterior only)

Choice of interior colour depends upon exterior colour and/or model selection. Due to the print production process, the colours shown throughout this brochure may vary slightly from the actual hue. Visit [hyundaicanada.com](http://hyundaicanada.com) or see your dealer for details. \* Available on Hybrid Limited models only.



# Model summary

## 2017 IONIQ hybrid

### Performance

<b>Engine</b>	1.6 GDI Atkinson Cycle DOHC 16-valve Inline 4-cylinder	<b>Battery type</b>	1.56 kWh Lithium-ion polymer (LiPB)
<b>Electric motor type</b>	32 kW (43 hp) Interior permanent magnet synchronous electric motor	<b>Drive configuration</b>	Front-wheel drive
<b>Horsepower</b>	139 hp @ 5,700 rpm (total system output)	<b>Transmission type</b>	6-speed EcoShift Dual Clutch Transmission
<b>Torque</b>	195 lb-ft @ 4,000 rpm (total system output)	<b>Drive Mode Select</b>	Eco / Sport modes
<b>Fuel system</b>	Gasoline Direct Injection (GDI)	<b>Suspension</b>	MacPherson strut (Front), Multi-link (Rear)
		<b>Cargo volume (trunk)</b>	750 L

### Fuel economy^ (L/100km)

**hybrid Blue:** 4.2 City / 4.0 Highway / 4.1 Combined  
**hybrid SE and Limited:** 4.3 City / 4.4 Highway / 4.4 Combined

### hybrid Blue - Standard equipment includes:

- 1.6L "Kappa" GDI I4 engine + 32 kW electric motor + 1.56 kWh lithium-ion polymer battery
- 6-speed EcoShift Dual Clutch Transmission
- Regenerative braking system
- 15" Eco alloy wheels with P195/65R15 Michelin LRRC tires
- Tire Mobility Kit
- Engine immobilizer
- Vehicle Stability Management, Electronic Stability Control, Traction Control System, Anti-lock Braking System
- Airbags (7): Driver's knee (1), front impact (2), front seat-mounted side impact (2), front/rear side curtains (2)
- Active grille shutters
- Speed-sensitive front windshield wipers
- Low windshield fluid warning light
- Rear spoiler
- Drive Mode Select
- Body colour door handles with approach lights
- Power windows with driver's auto up/down
- Heated, power-adjustable side mirrors
- Hill start assist
- Remote keyless entry
- 7.0" touch-screen audio with Hybrid Technology Display
- 6-speaker AM/FM/SiriusXM™/MP3 audio system
- Apple CarPlay™ and Android Auto™ connectivity
- iPod®/AUX/USB connectivity
- 12V power outlet (x2)
- Bluetooth® hands-free phone system with wireless audio streaming
- Steering wheel-mounted audio and telephone controls
- Rearview camera with dynamic guidelines
- Cruise control
- Automatic climate control
- PTC heater
- Automatic headlights
- Heated front seats
- 6-way manually adjustable front seats (including height adjustment for both)
- 60/40 split-fold rear seats
- Illuminated vanity mirrors
- Tilt and telescopic steering column adjustment
- Windshield acoustic film

### hybrid SE - Includes hybrid Blue standard equipment plus:

- Proximity keyless entry with push-button ignition
- Power tilt-and-slide sunroof
- 8-way power-adjustable driver's seat with adjustable lumbar support
- LED daytime running lights, tail lights, side mirror turn signal repeaters, interior lights
- Blind Spot Detection with Lane Change Assist and Rear Cross-Traffic Alert
- Heated, leather-wrapped steering wheel
- Heated rear seats

### hybrid Limited - Includes hybrid SE standard equipment plus:

- 17" Eco alloy wheels with P225/45R17 Michelin LRRC tires
- Rear parking assistance sensors
- Passenger auto up/down window
- Leather seating surfaces
- Electrochromic auto-dimming rearview mirror with HomeLink® transceiver and compass
- Chrome exterior/interior door handles
- Aluminum door sill plates
- Wireless phone charging
- Chrome grille coating
- Adaptive Cruise Control
- Lane Departure Warning System
- Autonomous Emergency Braking with pedestrian detection

### hybrid Limited with Tech Package - Includes hybrid Limited standard equipment plus:

- HID headlights with Adaptive Cornering System
- Driver's Integrated Memory System
- 8.0" touch-screen navigation system
- 8-speaker Infinity® premium audio system
- Rear console air vents
- Aluminum pedals

## 2017 IONIQ electric

### Performance

<b>Electric motor type</b>	88 kW (118 hp) Interior permanent magnet synchronous electric motor	<b>Drive configuration</b>	Front-wheel drive
<b>Horsepower</b>	118 hp	<b>Transmission type</b>	Single-speed Reduction Gear
<b>Torque</b>	218 lb-ft	<b>Drive Mode Select</b>	Normal / Eco / Sport modes
<b>Fuel system</b>	-	<b>Suspension</b>	MacPherson strut (Front), Coupled Torsion Beam Axle (Rear)
<b>Battery type</b>	28.0 kWh Lithium-ion polymer (LiPB)	<b>Cargo volume (trunk)</b>	650 L

### Fuel economy^ (L<sub>e</sub>/100km)<sup>1</sup> L<sub>e</sub> = Litres equivalent

1.6 City / 1.9 Highway / 1.7 Combined

### electric SE - Standard equipment includes:

- 88 kW electric motor + 28 kWh Lithium-ion polymer high-voltage battery
- Regenerative braking system with steering-wheel mounted paddles
- Electronic Parking Brake
- Torsion beam rear suspension
- 16" Eco alloy wheels with P205/55R16 Michelin LRRC tires
- Tire Mobility Kit
- Vehicle Stability Management, Electronic Stability Control, Traction Control System, Anti-lock Braking System
- Airbags (7): Driver's knee (1), front impact (2), front seat-mounted side impact (2), front/rear side curtains (2)
- Tilt and telescopic steering column adjustment
- Speed-sensitive front windshield wipers
- Power-adjustable, heated side mirrors
- Power windows with driver's auto up/down
- Rear spoiler
- Body colour door handles
- Hill Start Assist
- Blind Spot Detection with Lane Change Assist and Rear Cross-Traffic Alert
- LED daytime running lights, tail lights, side mirror turn signal repeaters
- Heated, leather-wrapped steering wheel
- Low washer fluid warning light
- Rearview camera with dynamic guidelines
- 8-speaker AM/FM/SiriusXM™/MP3 Infinity® premium audio system
- 8.0" high-resolution touch-screen navigation system
- Apple CarPlay™ and Android Auto™ connectivity
- Bluetooth® hands-free phone system with wireless audio streaming
- Steering wheel-mounted audio and telephone controls
- iPod®/AUX/USB connectivity
- Cruise control
- Automatic climate control with auto defogger
- Automatic headlights
- PTC Heater
- Proximity keyless entry with push-button ignition
- Cloth seats
- Heated front seats
- 6-way manually adjustable front seats (including height adjustment for both)
- 60/40 split-fold rear seats
- Rear console air ducts
- 12V power outlet (x2)
- SAE Combo-type quick charge port

### electric SE with Cold Climate Package - Includes electric SE standard equipment plus:

- Heat pump
- Battery temperature management system
- Heated rear seats

### electric Limited - Includes electric SE Cold Climate Package standard equipment plus:

- HID headlights with Adaptive Cornering System
- Lane Departure Warning System
- Adaptive Cruise Control
- Autonomous Emergency Braking with pedestrian detection
- Power tilt-and-slide sunroof
- Electric folding side mirrors with mirror puddle lamp
- Passenger auto up/down window
- LED interior lighting
- Leather seating surfaces
- 8-way power-adjustable driver's seat with adjustable lumbar support
- Driver's Integrated Memory System
- Wireless phone charging
- Electrochromic auto-dimming rearview mirror with HomeLink® transceiver and compass
- Aluminum pedals
- Chrome exterior/interior door handles
- Artificial leather armrest cover, instrument cluster

# Specifications

Standard [ • ], Not Available [ - ]

	2017 IONIQ hybrid				2017 IONIQ electric			
	Blue	SE	Limited	Limited with Tech	SE	SE with Cold Climate Package	Limited	
<b>Exterior</b>								
<b>Wheels and tires</b>								
15" x 6.0 Hybrid-design (A) aluminum alloy wheels	•	-	-	-	-	-	-	-
15" x 6.0 Hybrid-design (B) aluminum alloy wheels	-	•	-	-	-	-	-	-
17" x 7.0 Hybrid-design aluminum alloy wheels	-	-	•	•	-	-	-	-
16" x 6.5 EV-design aluminum alloy wheels	-	-	-	-	•	•	•	-
Tire Mobility Kit	•	•	•	•	•	•	•	•
<b>Lighting</b>								
Automatic headlights	•	•	•	•	•	•	•	•
Front door handle welcome lights	•	•	•	•	•	•	•	•
Projector beam halogen headlights	•	•	•	-	•	•	-	-
LED Daytime Running Lights	-	•	•	•	•	•	•	•
LED tail lights	-	•	•	•	•	•	•	•
LED side mirror turn signal repeaters	-	•	•	•	•	•	•	•
Bi-Xenon HID headlights with Adaptive Cornering System	-	-	-	•	-	-	-	•
<b>Outside mirrors</b>								
Heated power-adjustable mirrors, manual folding	•	•	•	•	•	•	-	-
Heated power-adjustable mirrors, electric folding	-	-	-	-	-	-	-	•
<b>Exterior trim</b>								
Active grille shutters	•	•	•	•	-	-	-	-
Chrome door handles	-	-	•	•	-	-	-	•
<b>Wipers</b>								
Front windshield, 2-speed intermittent, mist function	•	•	•	•	•	•	•	•
<b>Interior</b>								
<b>Seating</b>								
Heated front seats	•	•	•	•	•	•	•	•
Cloth seating surfaces	•	•	-	-	•	•	-	-
6-way manually-adjustable driver's seat including height adjustment	•	-	-	-	•	•	-	-
6-way manually-adjustable passenger's seat including height adjustment	•	•	•	•	•	•	•	•
60/40 split-folding rear bench seat with centre armrest and cupholders	•	•	•	•	•	•	•	•
8-way power-adjustable driver's seat with lumbar adjustment	-	•	•	•	-	-	-	•
Heated rear seats	-	•	•	•	-	•	•	•
Leather seating surfaces	-	-	•	•	-	-	-	•
<b>Multimedia</b>								
Bluetooth® hands-free phone system	•	•	•	•	•	•	•	•
iPod®/USB/auxiliary connectivity	•	•	•	•	•	•	•	•
Apple CarPlay™ and Android Auto™ connectivity	•	•	•	•	•	•	•	•
AM/FM/SiriusXM™/MP3 audio system with 6 speakers	•	•	•	-	-	-	-	-
7.0" display audio with Hybrid Technology Display	•	•	•	-	-	-	-	-
8.0" high-resolution touch-screen navigation system	-	-	-	•	•	•	•	•
8-speaker AM/FM/SiriusXM™/MP3 Infinity® premium audio system	-	-	-	•	•	•	•	•
<b>Interior trim</b>								
Chrome inside door handles	-	-	•	•	-	-	-	•
White-coloured trim accents	-	-	-	•	-	-	-	-
Blue-coloured trim accents	•	•	-	-	-	-	-	-
Copper-coloured trim accents	-	-	-	-	•	•	•	•
Artificial leather door trim inserts	-	-	•	•	-	-	-	•
Aluminum door scuff plates	-	-	•	•	-	-	-	•

	2017 IONIQ hybrid				2017 IONIQ electric			
	Blue	SE	Limited	Limited with Tech	SE	SE with Cold Climate Package	Limited	
<b>Interior (continued)</b>								
<b>Convenience features</b>								
Power windows with driver's auto up/down with pinch protection	•	•	•	•	•	•	•	•
Power door locks	•	•	•	•	•	•	•	•
Proximity keyless entry with push-button ignition	-	•	•	•	•	•	•	•
Rearview camera	-	•	•	•	•	•	•	•
Front console centre armrest with storage box and dual cupholders	•	•	•	•	•	•	•	•
Hill Start Assist	•	•	•	•	•	•	•	•
Cruise control	•	•	-	-	•	•	-	-
Power sunroof	-	•	•	•	-	-	-	•
Passenger's auto up/down window with pinch protection	-	-	•	•	-	-	-	•
Electrochromic auto-dimming rearview mirror with integrated HomeLink® transceiver and compass	-	-	•	•	-	-	-	•
Rear parking assistance sensors	-	-	•	•	-	-	-	-
Driver's Integrated Memory System for seat and side mirror positions	-	-	-	•	-	-	-	•
Adaptive Cruise Control	-	-	•	•	-	-	-	•
Electronic Parking Brake with Auto Vehicle Hold	-	-	-	-	•	•	-	-
SAE Combo-type quick charge port	-	-	-	-	•	•	-	•
Battery Temperature Management System	-	-	-	-	-	-	-	•
<b>HVAC</b>								
Dual-zone automatic climate control	•	•	•	•	-	-	-	-
Rear window defroster with timer	•	•	•	•	•	•	•	•
Rear seat HVAC ducts (mounted in centre console)	-	-	-	•	•	•	•	•
PTC Heater	•	•	•	•	•	•	•	•
Heat Pump system	-	-	-	-	-	-	-	•
<b>Steering wheel and instrumentation</b>								
Manual tilt and telescopic steering column adjustment	•	•	•	•	•	•	•	•
Audio, Bluetooth®, cruise control, and voice command controls	•	•	•	•	•	•	•	•
Heated, leather-wrapped	-	-	•	•	•	•	•	•
4.2" TFT LCD instrument panel display with multi-function trip computer	•	•	•	-	-	-	-	-
7.0" TFT LCD "Supervision" instrument panel display with multi-function trip computer	-	-	-	•	•	•	•	•
<b>Safety</b>								
<b>Restraint system</b>								
Airbags (7) - driver's knee (1), front impact (2), front seat-mounted side impact (2), front/rear side curtains (2)	•	•	•	•	•	•	•	•
Vehicle Stability Management	•	•	•	•	•	•	•	•
Electronic Stability Control with Traction Control System	•	•	•	•	•	•	•	•
Anti-lock Braking System with Electronic Brake-force Distribution and Brake Assist	•	•	•	•	•	•	•	•
Blind Spot Detection with Lane Change Assist and Rear Cross Traffic Alert	-	•	•	•	-	-	-	•
Lane Departure Warning System	-	-	•	•	-	-	-	•
Autonomous Emergency Braking with pedestrian detection	-	-	•	•	-	-	-	•



<sup>TM</sup>The Hyundai name, logos, product names, feature names, images and slogans are trademarks owned or licensed by Hyundai Auto Canada Corp.. Specifications, features, illustrations, accessories, materials and equipment and all other information shown in this brochure are based on the latest information available at the time of publication. Although descriptions are believed to be correct, accuracy cannot be guaranteed. Hyundai Auto Canada Corp. reserves the right to make any changes or modifications at any time, without notice or obligation, including, without limitation, in colour, specifications, features, accessories, materials, equipment and models. Some vehicles are shown with optional equipment. All Hyundai warranties have no deductible. <sup>†</sup>Fuel economy figures are based on manufacturer's testing and are used for comparison purposes only. Actual fuel efficiency may vary based on driving conditions and the addition of certain vehicle accessories. <sup>1</sup>IONIQ hybrid blue combined fuel economy. <sup>\*</sup>Class defined by the Global Automakers of Canada segmentation for 2017 model year compact hybrid vehicles. <sup>2</sup>Class defined by the Global Automakers of Canada segmentation for 2017 model year compact hybrid and electric vehicles. <sup>1</sup>Calculated based on a fully charged battery. <sup>††</sup>Based on manufacturer's testing and used for comparison purposes only. Actual range may vary based on driving conditions and the addition of certain vehicle accessories. <sup>‡</sup>Not all devices will be compatible. See Owner's Manual for further details. <sup>†††</sup>Autonomous Emergency Braking (AEB) is designed to detect vehicles that are directly in front of the vehicle. AEB will not detect all vehicles and objects. AEB may not work on winding or hilly roads, during certain weather conditions such as rain, snow, fog and any other times of limited visibility. AEB initiates full braking at speeds between 8 and 80 km/h (vehicle detection) or 8 and 69 km/h (pedestrian detection). AEB will not detect all pedestrians under certain conditions. See Owner's Manual for detailed descriptions of example conditions in which AEB may not detect a pedestrian. AEB is not a substitute for safe driving. Always check your surroundings when driving. See Owner's Manual for further details and limitations. <sup>2</sup>The Lane Departure Warning System operates when vehicle speed exceeds 70 km/h and only when the lane markings are clearly visible on the road and detected by the system. It will not prevent loss of control. See Owner's Manual for further details and limitations. <sup>3</sup>Never rely completely on Blind Spot Detection (BSD) and be sure to use proper lane changing procedures. BSD will not detect every object or vehicle and will not prevent accidents. Always look over your shoulder and use your mirrors to confirm clearance. See Owner's Manual for further details and limitations. <sup>4</sup>Android Auto™ is compatible with Android phones running Android Lollipop or newer. Android Auto may not be available on all devices and is not available in all countries or regions. Additional apps may be required. Visit [www.android.com](http://www.android.com) for further details and any applicable limitations. Subject to app compatibility. Android and Android Auto are trademarks of Google Inc.. <sup>5</sup>Apple CarPlay™ works with iPhone 5s, iPhone 5c, iPhone 5 and later models running the latest version of iOS 7 and above. CarPlay™ may not be available on all devices and may not be available in all countries or regions. Visit [www.apple.com](http://www.apple.com) for further details and any applicable limitations. Subject to app compatibility. Apple, Apple CarPlay and iPod are trademarks of Apple Inc.. The SiriusXM™ name is a trademark of SiriusXM Satellite Radio Inc.. Bluetooth® word mark and logos are registered trademarks owned by Bluetooth SIG, Inc.. HomeLink® is a registered trademark of Johnson Controls Inc.. Infinity® is a registered trademark of Harman International, Inc.. All other trademarks and trade names are those of their respective owners.