

FORD C-SERIES





A word about this catalog: Some of the equipment shown or described throughout the catalog is available at extra cost.

Ford's commitment to quality

For almost thirty years, Ford's C-Series has proven its worth in the toughest of all places — the streets of America. It has earned its right to the title "America's Truck" the hard way. C-Series is built tough to take it and it's built with Ford's total commitment to quality. Other tilt cabs have come and gone but Ford's



Ford builds quality trucks for you with on-the-line production teamwork.

C-Series keeps providing the same kind of everyday service it was designed to deliver.

Ford's C-Series Tilt Cab has built its reputation on a great work ethic; by spending more time on the road than in the shop; by providing the latest in state-of-the-art technology; and by providing you with a wide range of configurations and powertrains to match up to your job applications.

Ford C-Series advanced brake system

The advanced split brake system used on the C-Series provides many of the same features as air brakes but, at standard hydraulic prices.

The split service system features fade-resistant front disc brakes and cool-running rear drums plus a spring set rear wheel parking brake. The rear drum brakes are also designed for easy maintenance with quick visual wear checks, long-life 3/4-inch thick linings and fewer parts. The system uses hydraulic pressure instead of air and the brakes are operable immediately at engine start.



C-Series cab tilts up out of the way for easy servicing of undercab components.

Quality is Job 1.

At Ford, we're proud of the design and engineering excellence that go into every Ford truck that rolls off the line. We're equally proud of the modern facilities and equipment that help to produce them. But, most of all, we're proud of our people and the working partnership they've formed to bring you quality products.

The many Employee Involvement Programs we've instituted get assembly people, engineers and management working together toward a common goal of continuous quality improvement. It's paying off in improved quality. And we're going to keep on improving. Our philosophy is to build the quality into the truck at Job 1. We won't accept anything less. Why should you?

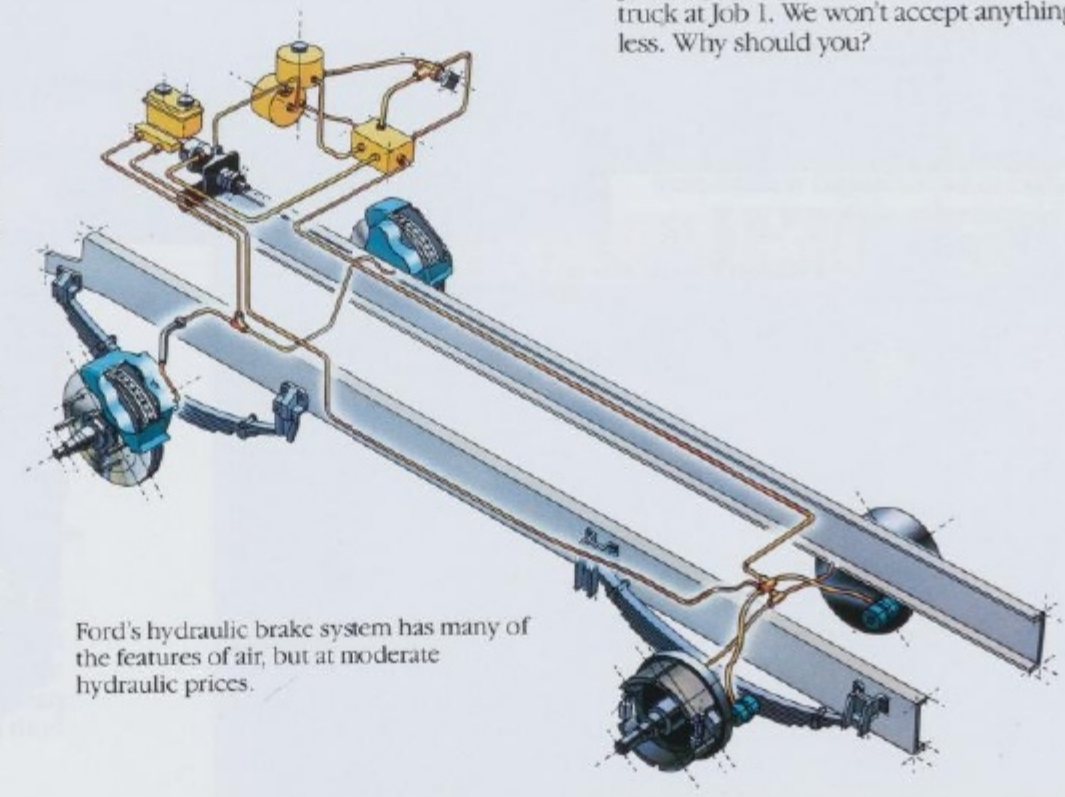

Ford's hydraulic brake system has many of the features of air, but at moderate hydraulic prices.

C-Series trucks are tailored for your tough job

Ford's C-Series line-up is a complete one offering you single and tandem axle trucks in a wide range of wheelbases and capacities to match your job requirements. For power, C-Series offers you a versatile choice of gas, LP-Gas engines or diesel engines.

Gasoline or LP-Gas engines

Ford's tough, efficient gasoline engines are specifically designed for tough jobs where you're out all day, on the move.

The C-Series line can also accommodate the very efficient LP-Gas engines. These LP-Gas versions of the proven V-8s provide LP-Gas economy and maintenance advantages.

Diesel engines

Over twenty years and 200,000 trucks ago, Ford started putting mid-range diesel power to work.

Today, Ford offers a broad range of 8.2L DDA diesels and Caterpillar 3208 engines in turbocharged versions from 145-horsepower all the way up to 225-horsepower.



C-Series interiors

Ford is a leader in designing truck cabs with a driver-oriented product philosophy.

In the '85 C-Series truck cabs, you, the driver, are the focal point. The ergonomically designed interior is laid out so that all controls are within comfortable reach and instruments are within clear view. The standard full-width bench seat can comfortably accommodate up to three good-sized people. And getting in and out of the C-Series cab is made easy with its low profile, large door openings and protected inboard steps.

A choice of two cab trim levels

The Custom Cab trim level (top right) features a full-width bench seat trimmed

in a knitted charcoal vinyl with charcoal facings and bolster. Because of its knit design, it "breathes" to help you keep cool. In addition to all the features of the Standard Cab, you also get a fold-down driver's armrest and cigarette lighter.

The Standard Cab trim level (bottom right) in C-600 through C-800 features foam-padded, full-width bench seat in charcoal all-vinyl trim. On 7000- and

8000-Series, the seat is covered with heavy-duty black vinyl. Other Standard Cab features are: power steering, tinted windshield, pivoting door vent windows with wedge-type locks, painted western mirrors with auxiliary convex mirrors, hardboard headlining, push-button door locks, reversible key locks, and deluxe bright-trimmed instrument cluster.

Individual seats

You can also order LS Unison driver's and matching passenger seats for the '85 C-Series. The seats, trimmed in heavy-duty vinyl, provide excellent driver and passenger comfort with adjustments for both height and size.



Built Ford Tough

Specifications

Series		Single-Axle (Gasoline- or Diesel-Powered)			Single-Axle (Diesel)		Tandem-Axle (Diesel)
		C-600	C-700	C-800	C-7000	C-8000	CT-8000
GVW RATING lb.	Max.	24,000	28,000	34,000	28,000	39,000	56,000
GCW RATING lb.	Max.	50,000	60,000	60,000	50,000	75,000	75,000
AXLE, FRONT Railing (lb.)	Std.	7,000	7,000	9,000	7,000	9,000	12,000
	Opt.	—	9,000	12,000	9,000	12,000, 16,000	16,000, 16,000
AXLE, REAR Railing (lb.)	Std.	15,000	17,500	19,000	17,500	19,000	34,000
	Opt.	17,500	19,000	22,000	19,000	22,000, 23,000 25,000(1)	38,000 44,000(1)
BRAKES, SERVICE Split system	Std.	Split-Hyd.	Split-Hyd.	Split-Hyd.	Split-Hyd.	Air	Air
	Opt.	HD Split-Hyd. Rear Air	HD Split-Hyd. Rear Air	HD Split-Hyd. Rear Air	HD Split-Hyd. Rear Air	Split-Hyd.	—
ENGINE 4V gasoline engine available in LP-Gas version	Std.	6.1L (370) 2V V-8	6.1L (370) 4V V-8	6.1L (370) 4V V-8	Cat. 3208N — 175-hp	Cat. 3208N — 175-hp(2)	Cat. 3208N — 175-hp(2)
	Opt.	6.1L (370) 4V V-8 8.2L N diesel (145-hp)(2) (165-hp)	6.1L (370) 2V V-8 7.0 (429) 4V V-8 8.2L N & T diesel (145-hp)(2) (165-, 200- & 205-hp)(2)	7.0L (429) 4V V-8 8.2L N & T diesel (145-hp)(2) (165-, 200- & 205-hp)(2)	Cat. 3208N — 185-hp(1) Cat. 3208N — 185-hp(1) Cat. 3208N — 200-hp(1)	Cat. 3208N — 200-hp Cat. 3208N — 210-hp(2) Cat. 3208T — 185-hp(1) Cat. 3208T — 210-hp Cat. 3208T — 225-hp(2)	Cat. 3208N — 200-hp Cat. 3208N — 210-hp(2) Cat. 3208T — 185-hp(1) Cat. 3208T — 210-hp Cat. 3208T — 225-hp(2)
CLUTCH (Dia. in.)	Std.	13 — 1-Plate(3,4)	13 — 1-Plate(3,4)	13 — 1-Plate(3,4)	14 — 1-Plate	14 — 1-Plate(5)	14 — 1-Plate(5)
TRANSMISSIONS	Std.	4-Spd.	4-Spd.	5-Spd.	5-Spd.	5-Spd.	5-Spd.
SPRINGS, FRONT Capacity @ Grd. (lb.)	Std.	3,500	3,500	4,500	3,500	4,500	6,000
	Opt.	4,500	6,000	6,000	4,500	6,000	—
SPRINGS, REAR(6) Capacity @ Grd. (lb.)	Std.	8,500	8,500	8,500	8,500	8,500	17,000
	Opt.	11,000	11,000	11,000	11,000	11,000, 11,670	19,000(1), 22,000(1)
POWER STEERING	Std.	Std.	Std.	Std.	Std.	Std.	Std.
WHEELS(7)	Std.	Cast Spoke	Cast Spoke	Cast Spoke	Cast Spoke	Cast Spoke	Cast Spoke
	Opt.	6- or 10-Hole Disc	6- or 10-Hole Disc	10-Hole Disc	6- or 10-Hole Disc	10-Hole Disc	10-Hole Disc
TIRES (Tube-type) — Maximum(8)	Std.	8.25x20 10PR	8.25x20 10PR	9.00x20 10PR	8.25x20 10PR	9.00x20 10PR	9.00x20 10PR(10)
	Opt.	9.00x20 12PR(9)	10.00x20 12PR(9)	11.00x22 14PR(9)	10.00x20 12PR(9)	11.00x22 14PR(9)	11.00x22 14PR(9)

NOTE: Use adequate tires for loads and type of service. 1) PEO. 2) NA Calif. 3) 14" w/8.2L. 4) 13"-2 plate clutch included with Clark 551, 557V and all Spicer transmissions with gas engines. 5) Includes 13"-2 plate clutch with Cat. 3208N-200 and 210 hp and 14" 2-plate clutch with Cat. 3208T-210 & 225 hp. 6) Includes auxiliary springs on single axle models. 7) 10-hole wheels available in steel or aluminum. 8) Flotation tires available for tandem models, front axle only. Consult your Ford Dealer. 9) Equivalent tubeless and tubeless radial tires are available. 10) 10.00x20F 12PR standard on front axle.

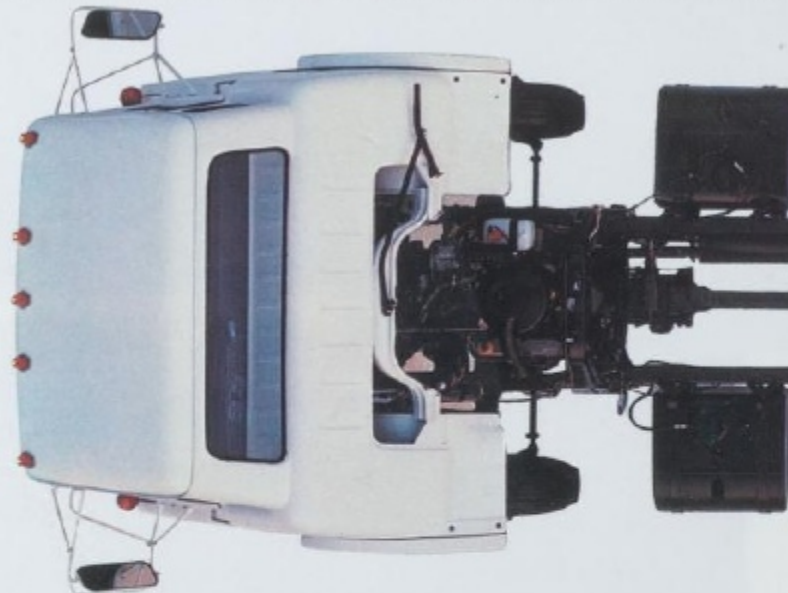

Ford built-in-quality

Ford designs and builds tough trucks to meet and overcome the formidable daily challenges of the work place. Heat. Cold. Big loads. Rough roads. Demanding schedules. That's why such meticulous

care and thoroughness go into every detail of Ford trucks. From the tilting cab in front to the rugged high-capacity single or tandem axles in the rear, Ford C-Series is the truck for your job.

Street smart maneuverability

Wide-track front axles have large wheel-cut angles for tight turns in traffic and snaking through congested docks or alleys. Turning diameters as small as 31.6 ft., curb to curb. Power steering, standard across the line, aids maneuverability.

Parts and service almost everywhere

Ford's commitment to service extends through a network of more than 4,650 truck dealers, including over 260 who specialize in heavy-duty trucks. They're backed by a modern state-of-the-art computer system linking 20 parts distribution centers that handle a full line of quality Motorcraft and Ford parts.

Ford tilts its entire cab for easy access

The C-Series cab easily tilts 45° exposing the engine, clutch, transmission and accessories for convenient routine service or repairs.

Ford C-Series Optional Equipment

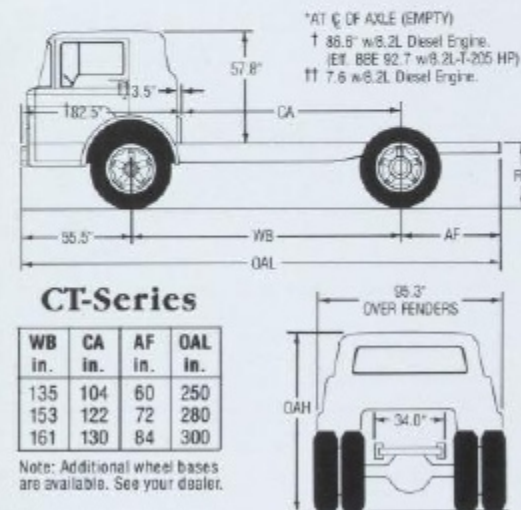

Dimensions C-Series

WB in.	CA* in.	AF in.	OAL in.	FH in.	OAH in.
99(1)	72	51	206	34	92
111	84	51	218	36	93
135	108	60	251	37	95
153	126	60	269	36	93
175	148	95	326	37	95
206(2)	179	95	357	40	95

Dimensions are for base models w/standard equipment.
* Subtract 4.1" for Diesel Engine.
(1) C-700 only.
(2) C-700, 7000 only.

Chassis

Alternators — 60 or 75 amp. or Leece Neville 105 or 130 amp.*

Batteries — maintenance-free

Gas Engines:

Std. one 45 amp-hr. (380 CCA)

Opt. one 63 amp-hr. (535 CCA)

DDA 8.2L diesel engines:

Std. two 63 amp-hr. (535 CCA)

Opt. three

Caterpillar 3208 Series diesels:

Std. two 93 amp-hr. (635 CCA)

Opt. three

Engine block heater

Ether cold starting aid with diesel engines (less canister)

Extra cooling radiator

Front tow hooks

Fuel pump, electric (gas engines; incl. w/7.0L (429) engine)

Fuel tanks (LH and/or RH): 50-gal. or 75-gal. steel D-tank

Silicone hose package (7000-8000)

Stemco wet-type wheel seals

Tachometer, electric (gas or 8.2L engines; 600 or 700 Series)

Tractor package with trailer air and electrical line connections.

Cab

All tinted glass (tinted windshield std.)

Brush-type grille guard

Chrome cab assist handles

Chrome front bumper

Chrome grille*

Dual horns (electric, or air on air-equipped models)

L-S Unison individual seats

Padded instrument panel

Parallel-action windshield wipers

Push-button AM radio

Stainless steel western mirrors with convex auxiliary mirrors

Western lighted or retrac* mirrors with convex auxiliary mirrors

*PEO

Ask your Ford Dealer about additional optional equipment available on all Ford trucks.

Product Changes

Ford Truck Operations reserves the right to change product specifications at any time without incurring obligations. It is important to note also that some of the items shown on vehicles in this publication are available through retail organizations and establishments not connected with Ford Motor Company. Availability, price, quality and durability of these items rest solely with the respective manufacturers and their sales organizations, and Ford assumes no responsibility for their use.

Federal regulations such as those issued by the National Highway Traffic Safety Administration, the Environmental Protection Agency of the Federal Highway Administration or issued pursuant to the Occupational Safety and Health Act (OSHA) and/or state and local laws and regulations, may require additional equipment for the particular use you intend for the vehicle. It is the buyer's responsibility to determine the applicability of such laws and regulations to the buyer's intended use for the vehicle, and to arrange for the installation of required equipment. Your Ford Dealer has information about the availability of many items of equipment which can be ordered for the vehicle.

"Ask your Ford Dealer"

Following publication of this catalog, certain changes in standard equipment, options, prices and the like, or product delays, may have occurred which would not be included in these pages. Your Ford Dealer is your best source for up-to-date information.

Options availability

Some options displayed or described here and elsewhere in this catalog are available at extra cost and may be offered in combination with other options or subject to additional ordering requirements or limitations. Your Ford Dealer has the latest information.



**NOW MORE THAN EVER
FORD MEANS BUSINESS
IN BIG TRUCKS**

Get it together — buckle up.

FTO 8522 Litho in U.S.A. 8/84

FORD C-SERIES

TRUCK OPERATIONS

