

CITROËN C5 110 HDi VTX+

MARCH 2006

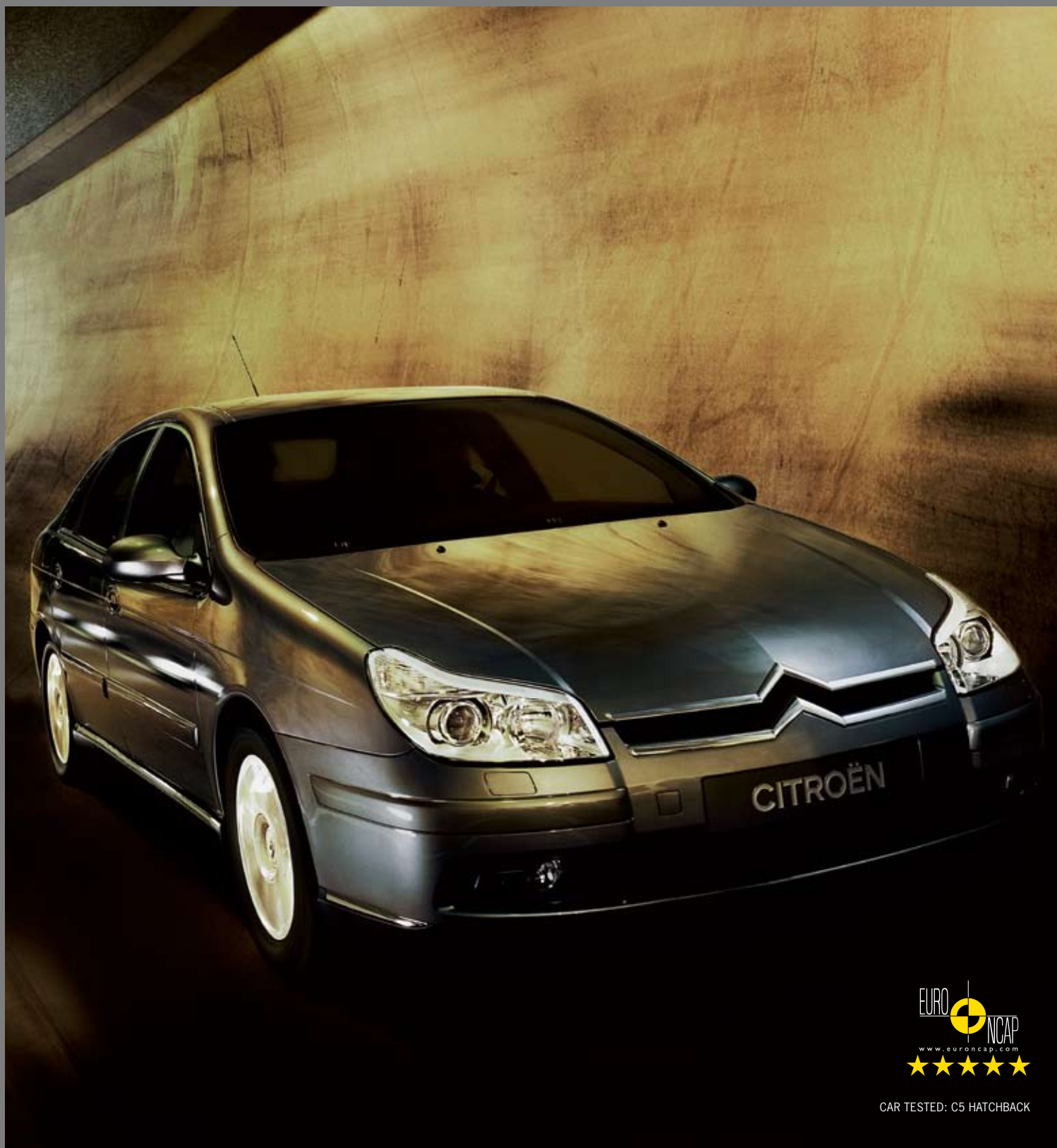

CAR TESTED: C5 HATCHBACK

Citroën C5 110 HDi VTX+

Citroën have developed our exciting new C5 model specifically for business users.

Based on the C5 1.6HDi VTR, the new C5 110 HDi VTX+ is available in either Hatchback or Estate versions with Metallic Paint, NaviDrive (satellite navigation) and 6-CD Autochanger as standard at a lower retail price than the VTR.



STANDARD KEY FEATURES OF VTX+

Navidrive Pack

- Colour Satellite Navigation fully integrated into the console, with full voice guided UK mapping
- Hands free telephone with access to address book and audio system
- Voice activation facility for navidrive and phone system

Safety

- Five star Euro NCAP award.
- ESP (Electronic Stability Programme) detects under or over steer of the vehicle modifying the engine's torque and applying one or more brakes to maintain stability and control.
- Seven airbags, comprising adaptive driver's and front passenger's airbags, front lateral airbags, side window airbags and steering column airbag.
- Automatic activation of hazard warning lights (in case of rapid deceleration or impact).
- ABS with Electronic Brakeforce Distribution (EBD) and Emergency Braking Assistance (EBA).



Comfort

- Variable power assisted steering
- Automatic digital air conditioning with separate controls for driver and passenger
- Height adjustable driver's seat with adjustable lumbar support
- Leather steering wheel
- Cruise control with speed limiter
- Hydractive 3 suspension giving self levelling, constant ride height
- RDS Radio / CD player with 6 speakers and CD auto changer and steering mounted controls
- Electric front and rear windows with one touch operation and anti-pinch
- Automatic illumination of headlamps
- Automatic rain sensitive windscreen wipers

Security

- High frequency remote control central locking with deadlocks
- Anti-theft alarm
- Automatic re-locking after 30 seconds
- Transponder immobiliser
- Automatic boot locking (when car in motion)

Style

- Body colour bumpers, skirts, and side rubbing strips
- 16" 'Olympus' Alloy wheels
- Your choice of any colour in the range including metallic paint



Not too taxing a decision

Tax liability on a new VTX+ Hatchback

CO₂ 142 g/km = lowest tax band of 15%

VTX+ launch OTTR price of £15,095
Therefore p11D of £14,942 x 18% = BiK value = £2,689.56

Cost to 40% tax payer is £1075.82 per year

THAT'S JUST £89.65 PER MONTH!

	Citroën C5 110 HDi VTX+	Ford Mondeo 90 TDCi LX	Vauxhall Vectra 120 CDTi Exclusiv	Peugeot 407 110 HDi S	Renault Laguna 95 DCi Expression	Volkswagen Passat 105 TDi S
OTR Price	£15,095	£16,300	£15,750	£16,250	£16,250	£16,170
Comfort and convenience						
Colour satellite navigation, map & GSM phone	✓	x	x	x	✓	x
Dual zone climate control	✓	x	x	x	x	x
Steering wheel type	leather	plastic	plastic	plastic	leather	plastic
6-CD Autochanger	✓	x	x	x	✓	x
Computer (Speed/Fuel consumption)	✓	✓	x	✓	✓	✓
Exterior						
Alloy wheels	✓	x	x	x	✓	✓
Metallic paint	✓	x	x	x	x	x
Safety						
Airbags	7	6	6	7	6	6
ESP with electronic traction control	✓	x	x	✓	x	✓
Cruise control with speed limiter	✓	x	x	✓	✓	x
Automatic illumination of headlamps & front wipers	✓	x	x	x	✓	x

NOTE : Competitor cars shown are the lowest priced diesel models available in their ranges.



Hatchback

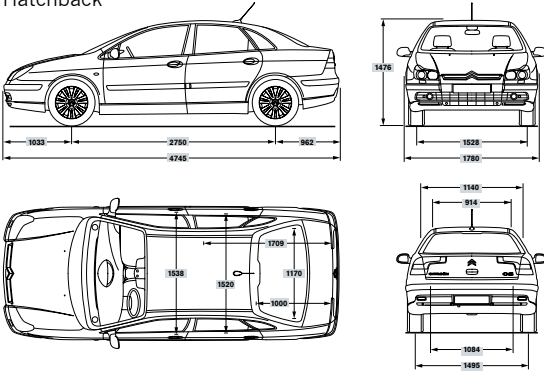

Estate

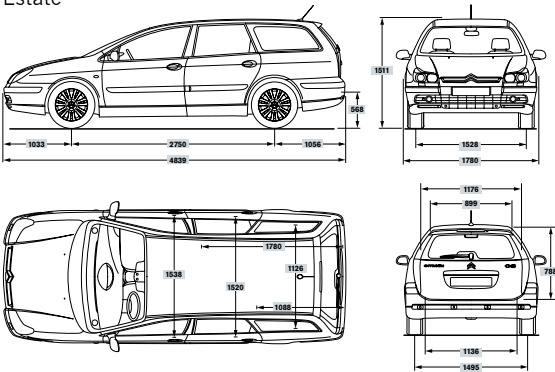

All measurements in millimetres

1.6HDi 110hp	Hatchback	Estate
Engine (Diesel)		
Capacity (cc)	1560	
Cylinders	4 in line	
Bore and stroke (mm)	75.0x88.3	
Max power DIN (hp/rpm)	110/4000	
Max torque DIN (lb. ft/rpm)	177/1750	
Fuel system	High pressure direct diesel injection	
Transmission		
Five speed manual	●	
Clutch type	Dry single plate	
Performance		
Max speed (mph)	118	116
0-62 (secs)	11.3	11.5
Standing 1000m (secs)	33.4	33.7
N.B. All figures driver alone		
Economy Litres/100km (mpg)		
Urban cycle	6.8 (41.5)	6.9 (40.9)
Extra urban	4.5 (62.8)	4.6 (61.4)
Combined	5.4 (52.3)	5.5 (51.4)
N.B. Official Government test fuel consumption figures		
CO₂ Emissions (g/km)		
	142	145
Wheels & Tyres		
16" 'Olympos' wheels with 215/55 R16 tyres	●	
Weights (kg)		
Unladen weight	1424	1442
Max laden weight	1944	2056
Max Towing weight braked	1300	1300
Max tow hitch download	75	75
Max roof rack load	75	75
Brakes	Servo assisted hydraulic dual circuit brakes. Front and rear discs. ABS with EBD and Emergency Braking Assistance (EBA)	
Steering	Hydraulic variable power assisted steering	
Suspension	Hydractive 3 with automatic ride height adjustment	
Fuel Tank Capacity Litres (gallons)	66 (14.5)	
Boot Volumes & Dimensions		
Seats up - below parcel shelf (litres VDA)	471	563
Seats up - up to roof (litres VDA)	-	893
Seats down - up to roof (litres VDA)	1315	1658
Depth under parcel shelf (mm)	554	481
Sill height -min/max (mm)	731	568 - 493/653



www.citroën.co.uk

K10437

Citroën UK Limited, 221 Bath Road, Slough, SL1 4BA

NOTE: Every endeavour has been made to ensure that the information and details contained in the specification leaflet were accurate at the time of going to press March 2006. However the company reserves the right, whilst preserving the essential characteristics of the models described, to introduce at any time modifications, changes of details, equipment or accessories. Every effort will be made to bring this leaflet up to date, but in order to avoid any misunderstandings please consult your Dealer. ▲ Prices and specifications correct at time of going to press. Euro NCAP date assessed: November 2004.