

 **CITROËN XSARA**

Picasso

PRODUCT & TECHNICAL
INFORMATION

XSARA PICASSO VTX

JUNE 2006



EURO NCAP
www.euroncap.com
★★★★★

Citroën Xsara Picasso VTX

Based on the specifications of the Xsara Picasso Desire, the new Xsara Picasso VTX is available with metallic paint, alloy wheels, and cruise control as standard. Additionally you can add to the standard specifications with two low cost options to give your VTX the extra equipment you want. There are also three engines to choose from: a frugal Diesel 1.6HDi 92hp, or two petrol engines: a 1.6i 16V 110hp and the 2.0i 16V Auto.

Standard Key Features of VTX

Safety

- Four star Euro NCAP rating for occupant protection.
- ESP (Electronic Stability Programme) including traction control detects under or over steer of the vehicle modifying the engine's torque and applying one or more brakes to maintain stability and control. Available only on 2.0i Auto.
- ABS with Electronic Brakeforce Distribution (EBD).
- Driver's, front passenger's and front lateral airbags.
- Height adjustable front seat belts with pre-tensioners and force-limiters
- Front fog lights

Comfort

- RDS stereo radio/CD player with six speakers and steering mounted controls
- Electric front and rear windows with one-touch operation on the driver's side
- Cruise control
- On-board trip computer
- Electric and heated door mirrors
- Heat reflecting windscreen
- Air conditioning
- Leather steering wheel
- Front folding armrests

Security

- High frequency remote control central locking
- Automatic door and boot locking (when car in motion)
- Transponder immobiliser

Style

- 'Melbourne' 15" alloy wheels
- Body colour painted bumpers, side rubbing strips, door mirrors, handles and rear number plate moulding
- Metallic/Pearlescent paint

Options available

- Electric fullsize glass sunroof
- Satellite navigation system



Colours and trim





Not too taxing a decision

Tax liability on a new Xsara Picasso 92 HDi VTX

CO₂ 135 g/km = lowest tax band of 18%

VTX launch OTR price of £11,650 therefore p11D of £11,502 x 18% = BiK value = £2,070

Cost to 40% tax payer is £828 per year

THAT'S JUST £69.01 PER MONTH!



Model	Citroën Xsara Picasso HDi 92 VTX	Ford Focus C-Max TDCi 90 LX	Renault Scenic Authentique 86 dCi	Vauxhall New Zafira CDTi 120 Life	Volkswagen Touran TDi PD 90 S
OTR Price	£11,650	£15,190	£14,620	£17,100	£15,545
Comfort and Convenience					
Air conditioning	✓	✓	×	○	✓
Steering wheel	Leather	Plastic	Plastic	Plastic	Plastic
Electric front & rear windows	✓	×	×	×	×
Front folding armrests	✓	×	×	×	○
RDS stereo radio/CD with steering mounted controls	✓	✓	○	×	×
Number of speakers	6	6	4	6	4
Exterior					
Metallic Paint	✓	○	○	○	○
Alloy wheels	✓	○	×	×	○
Body colour bumpers, door handles and side protection mouldings	✓	×	×	×	×
Safety					
Front fog lights	✓	×	×	×	○
Cruise Control	✓	×	×	○	✓
Taxes					
Benefit in Kind payable over 3 years (40% tax band)	£2,484	£3,244	£3,126	£4,672	£4,058
National Insurance payable over 3 years	£795	£1,038	£1,000	£1,495	£1,299

✓: standard ○: optional at extra cost ×: not available

NOTE : Competitor cars shown are the lowest priced diesel models available in their ranges. P11D figures provided by Carcost - June 2006. OTR prices shown include delivery to dealer, number plate, first registration fee, and graduated vehicle excise duty; all correct at time of going to press.

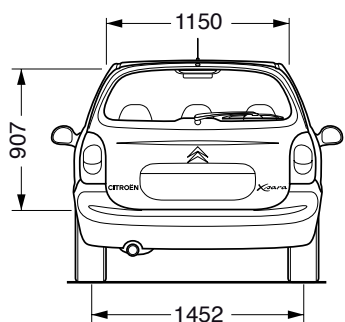
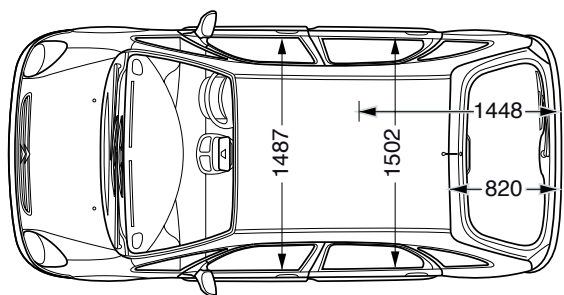
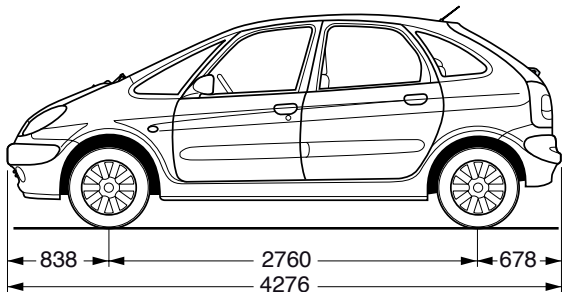
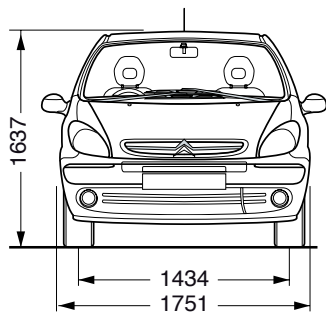

All measurements in millimetres

Xsara Picasso VTX

Engine	1.6Hdi 16V 92hp Diesel	1.6i 16V	2.0i 16V Auto
Capacity (cc)	1560	1587	1997
Cylinders	4 in line	4 in line	4 in line
Bore and stroke (mm)	75.0 x 88.3	75.0 x 88.3	85.0 x 88.0
Max power DIN (hp/rpm)	92/4000	110/5800	137/6000
Max torque DIN (lb. ft/rpm)	159/1750	108/4000	141/4100
Fuel system	High pressure direct Diesel injection	Multipoint fuel injection	
Transmission			
Five speed manual	●	●	
Clutch type	Dry single plate		Automatic
Performance			
Max speed (mph)	109	112	119
0-62 (secs)	13.8	11.4	10.9
Standing 1000m (secs)	35.8	34	33.8
N.B. All figures driver alone			
Economy Litres/100km (mpg)			
Urban cycle	6.5 (43.5)	9.5 (29.7)	12.5 (22.6)
Extra urban	4.3 (65.7)	6.0 (47.1)	6.4 (44.1)
Combined	5.1 (55.4)	7.3 (38.7)	8.6 (32.9)
N.B. Official Government test fuel consumption figures			
CO₂ Emissions (g/km)			
	135	172	205
Wheels & Tyres			
15" 'Melbourne' alloy wheels with 185/65 R15 tyres	●	●	●
Weights (kg)			
Unladen weight	1300	1240	1326
Max laden weight	1850	1800	1832
Max Towing weight braked	1300	1300	1300
Max tow hitch download	80	80	80
Max roof rack load	80	80	80
Brakes	Front discs, rear drums		Front and rear disks
Steering	Power assisted steering		
Suspension	Anti-roll bars front and rear, front Macpherson strut/coil springs, rear independent trailing arms/torsion bars		
Fuel Tank Capacity Litres (gallons)	60 (13.2)	55 (12.1)	55 (12.1)
Boot Volumes & Dimensions			
Seats up - below parcel shelf (litres VDA)	550	550	550
Seats folded forward - up to roof (litres VDA)	1969	1969	1969
Seats removed - up to roof (litres VDA)	2128	2128	2128



K10515

 **CITROËN**
Fleet

Citroën UK Limited,
221 Bath Road, Slough, SL1 4BA
www.citroën.co.uk

NOTE: Every endeavour has been made to ensure that the information and details contained in the specification leaflet were accurate at the time of going to press June 2006. However the company reserves the right, whilst preserving the essential characteristics of the models described, to introduce at any time modifications, changes of details, equipment or accessories. Every effort will be made to bring this leaflet up to date, but in order to avoid any misunderstandings please consult your Dealer. Prices and specifications correct at time of going to press. Pictures shown are for illustrative purposes only. Euro NCAP date assessed: March 2001.