

DATSUN STANZA



MARCH 1983





DATSUN STANZA BY NISSAN



Introducing the Datsun Stanza, an advanced range of family cars designed for exceptional economy, maximum interior space and an extremely high level of comfort and convenience.

All the technological resources of Nissan/Datsun have been employed to meet these design criteria.

The result is a new dimension in family motoring. A choice of 3 door, 5 door and 4 door saloon, all with front wheel drive and powered by completely new lightweight engines that give outstanding performance and truly exceptional economy.

The engine is of advanced cross-flow overhead camshaft design and is one of the lightest of its class in the world. As a result, Nissan have been able to adopt rack and pinion steering with front wheel drive to give the family sized Stanza the light responsive handling and easy manoeuvrability of a smaller car.

All models have a 5-speed gearbox with two overdrive "economy" gears, which means that cruising at 70 miles an hour the engine speed is a lazy

2800 revs per minute for very economical motoring.

Because of their compact size, the engine and transmission can be fitted transversely to give maximum interior space for passengers and their luggage. Fully independent strut suspension with a dual shock absorber system, gives the Stanza an impressively smooth and quiet ride.

Styling is eye-catching and attractive in a wind-cheating shape with a drag coefficient of only 0.38. One third of the body construction uses high tension steel for strength and low weight.

There are six models in the Stanza range, including a 1.8 litre 5-door hatchback with automatic transmission. All of them combine advanced engineering efficiency with an exceptionally high standard of comfort and luxury and new Datsun innovations. And because they are built by Nissan, the world's third largest car manufacturer, you can rely on the quality that has made the Datsun name famous the world over.



Comfort for all the family

Sit inside the Datsun Stanza and take a look around you. The Stanza is one of the most spacious cars in its class so there's plenty of room for you and your passengers to relax and be comfortable.

The whole interior is colour co-ordinated with upholstery, trim and carpets matching in an attractive blend of shade and colour. Sculptured seats are thickly padded with a new type of high density urethane that gives excellent support particularly on long journeys. Front seats are fitted with adjustable head restraints and all seats are upholstered in an attractive, durable cloth. The driver's seat features an adjustable lumbar control to vary the amount of support to the lower back.

The Stanza also offers generous accommodation for rear seat passengers in wide, comfortable contoured seats. On the saloon a rear centre armrest can be folded

down for additional support. On the three door hatchback the front passenger seat automatically slides forward when the seat back is tilted allowing easy access to and from the rear seats.

The Stanza is equally accommodating for luggage and equipment. The saloon boot is over five feet wide, almost three feet long and 18 inches deep. On hatchback models the rear seats fold down individually so you can choose whichever combination of passengers and equipment that suits your particular needs.

The Stanza features no less than 10 handy storage spaces from a lockable, illuminated glovebox to useful pockets in the front door armrests. On hatchback models there's a hinged parcel shelf allowing easy access to the luggage area from inside the car.



GL Instrument panel



SGL Interior



An impressive array of equipment

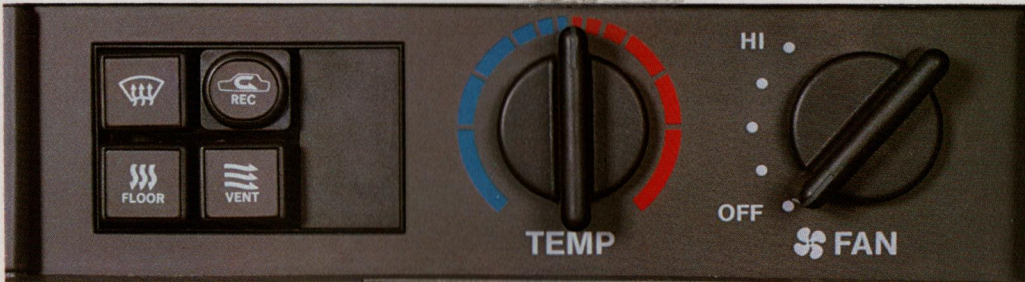

Advanced heating and ventilation



SGL Instrument panel

The view from the driver's seat of the Datsun Stanza is impressive. Instrumentation is neat, efficient and informative. A large 120 mph speedometer sits directly in front of the driver. A bank of warning lights monitors low fuel, low brake and washer fluid levels, headlamp and stop lamp failure, door ajar, handbrake on, rear fog lamps on, heated rear window on, oil pressure and headlamp main beam. A quartz clock gives you a highly accurate time check with digital display and day/date feature on SGL models. There's a push

button MW/LW radio, illuminated cigar lighter, interior boot and fuel lid release and much more. Additional features on SGL models include rev. counter, voltmeter, oil pressure gauge and variable instrument lighting.

The Datsun Stanza has a highly advanced heating and ventilation system providing you with all weather comfort literally at the touch of a button. Heater vents are controlled pneumatically by four push buttons directing the air flow to the windscreen, to the feet, through the adjustable central and face level air vents or in circulation around the car. The powerful heater has a four speed fan. There are side window demisters and rear passengers have their own ducted heating. To cope with bad weather conditions the Stanza has two-speed wipers with wash/wipe and a useful intermittent wipe that you can set to operate at 2, 4, 7 and 10 second intervals depending on the conditions. There are also integral rear fog lamps, a heated rear window and on the hatchbacks a rear window wash/wipe. For safer night driving all Stanza models have powerful halogen headlamps, built-in reversing lights and anti-dazzle interior mirror. Other safety features include side indicator repeaters, hazard warning lights, child-proof locks on rear doors, wraparound moulded bumpers and body protective side mouldings.

There are many convenient features on the new Datsun Stanza. The two door mirrors can be adjusted from inside the car. A warning chime reminds you not to leave your lights on when you park your car. There's a luggage area lamp, maintenance free battery and so on. On the 3 door SGL hatchback the rear windows can be opened by remote control from the driver's seat.

The SGL hatchback models are also fitted with stylish alloy wheels and on the five door, tilt adjustable, power assisted steering. On all SGL models an electrically operated sun roof is available as an optional extra.



Quality engineering for reliability and long life

The Datsun Stanza combines advanced design with precision engineering to give you the reliability for which Datsun are world famous.

In the engine, for example, the long stroke piston design gives high torque with minimal vibration and friction levels have been substantially reduced. This achieves high performance with maximum durability. On the suspension, coil springs are fitted in an offset position outside the struts to improve riding comfort and reduce wear on the piston rod sleeves in the strut.

The Stanza body is constructed to give maximum protection to occupants and also to prevent corrosion. Component panels are spot welded by multiple welder machines in a single smooth process that gives improved rigidity and a high quality finish. The body structure is designed to eliminate places where water or mud can collect. Special corrosion-resistant zinc chromate sheet steel is used in many areas of the body and several coats of weather-resistant epoxy paint are applied by an electrodeposition process.

In every aspect of design and construction the Datsun Stanza sets new motoring standards that you'll enjoy for many years to come.

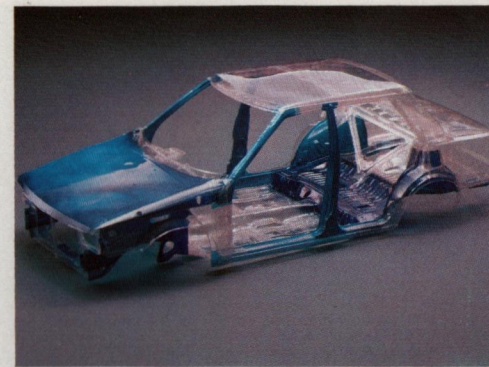

High tension steel



Corrosion-resistant zinc chromate sheet steel



Saloon interior

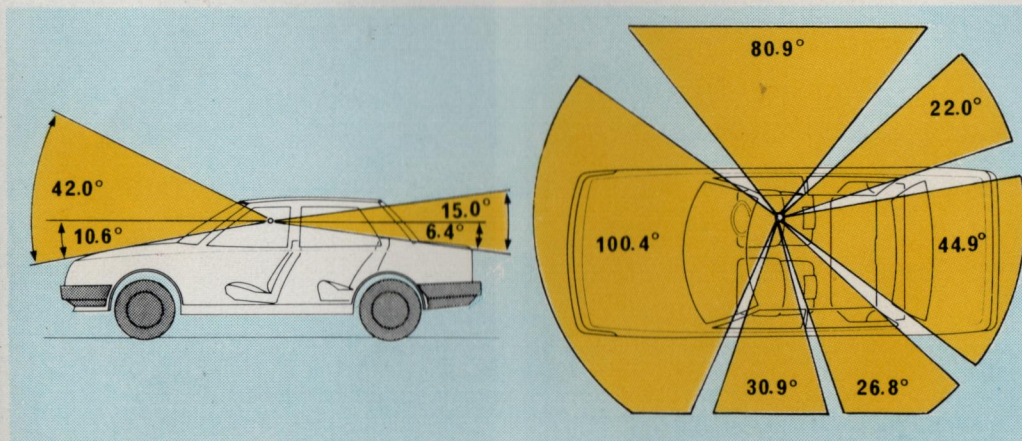

Outstanding all round visibility

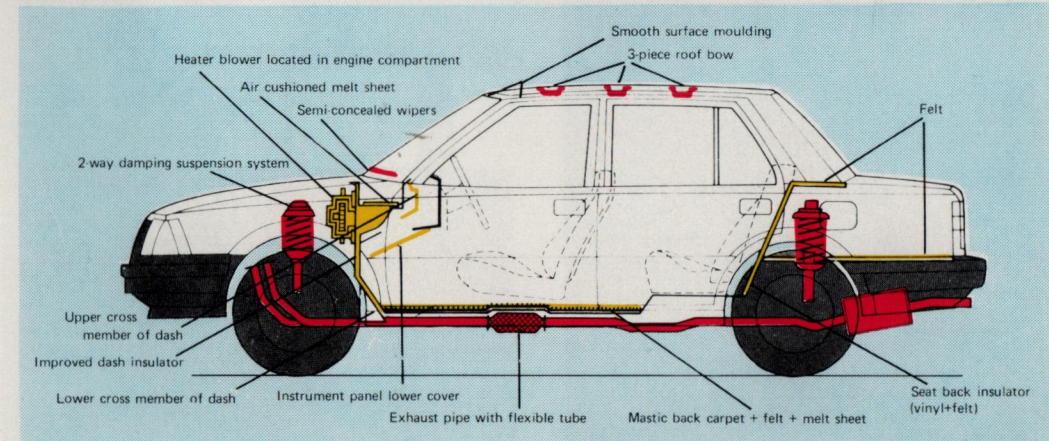

Comprehensive sound insulation

Take a closer look at some of the features on the new Datsun Stanza



Hinged rear parcel shelf (Hatchbacks)



Rear side window opener (3-door SGL)

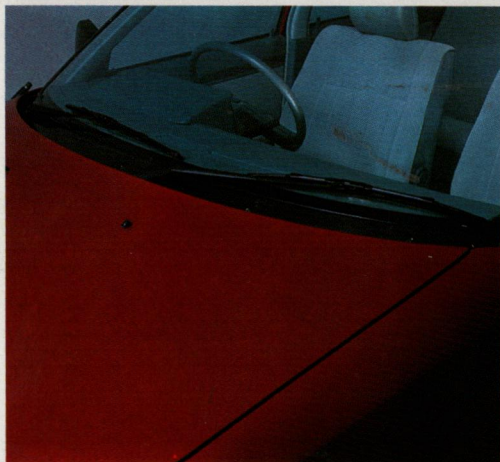

Semi concealed wipers

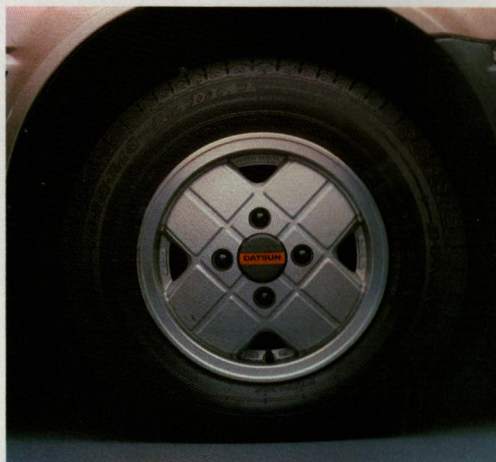

Stylish alloy wheels (SGL)



Armrests with pockets



Rear wiper with washer (Hatchbacks)



Child safety rear door locks

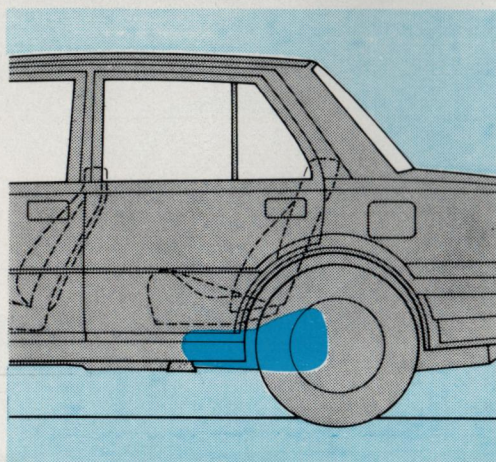

Fuel tank under rear seat for safety



Wraparound moulded bumpers

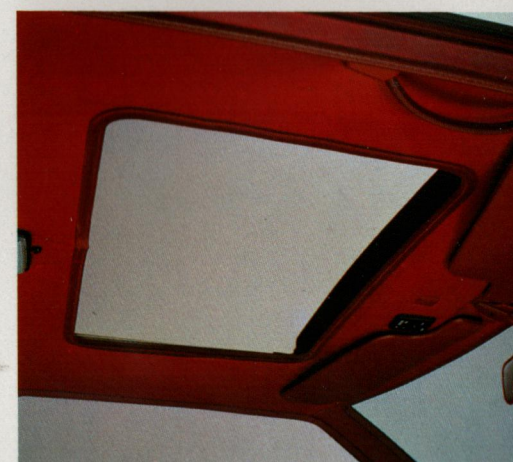

Electric sunshine roof (SGL optional extra)



Folding split rear seat (Hatchbacks)



Rear light cluster (5-door)



Remote control door mirror



Centre console box with lid (excluding 3 door SGL)

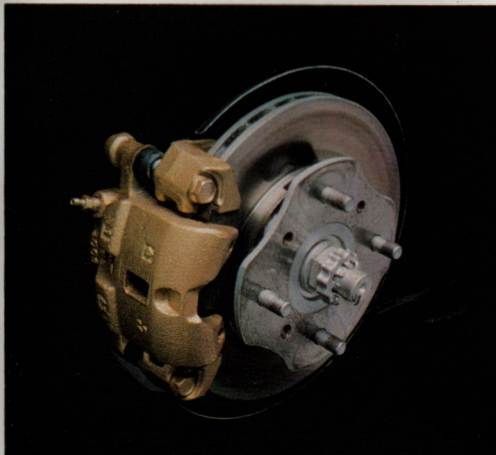

Ventilated front disc brakes

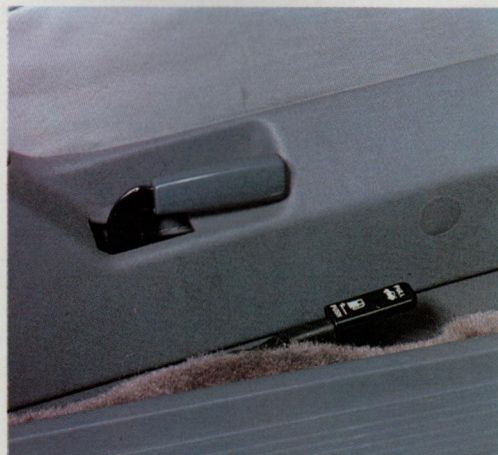

Interior boot and fuel lid release

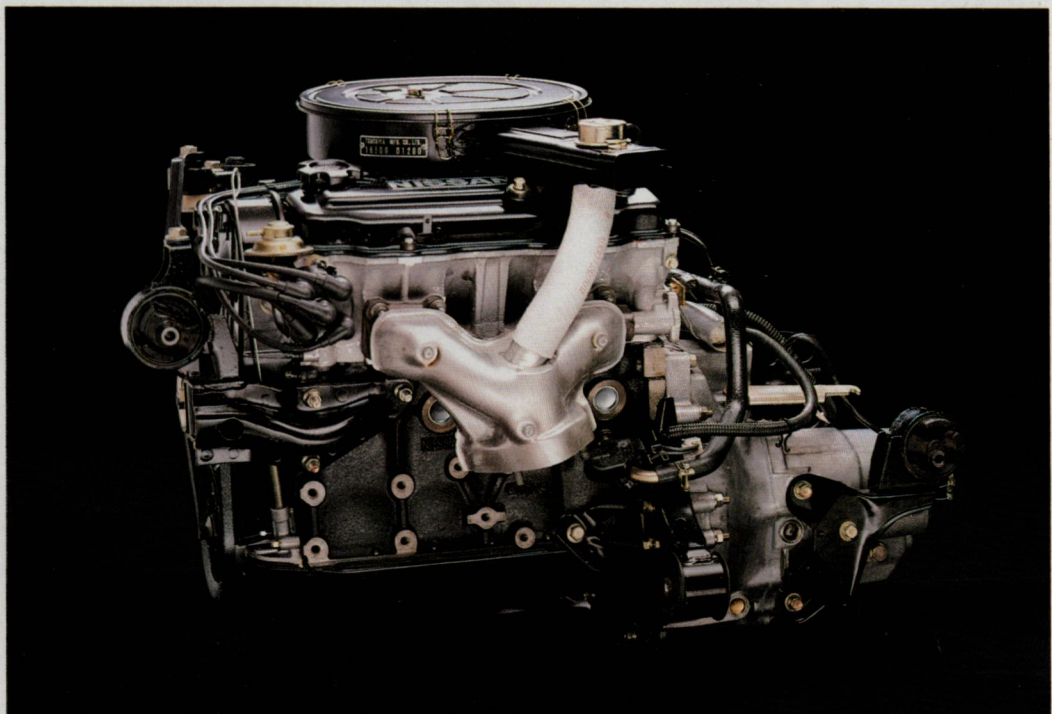

Cross-flow O.H.C. engine

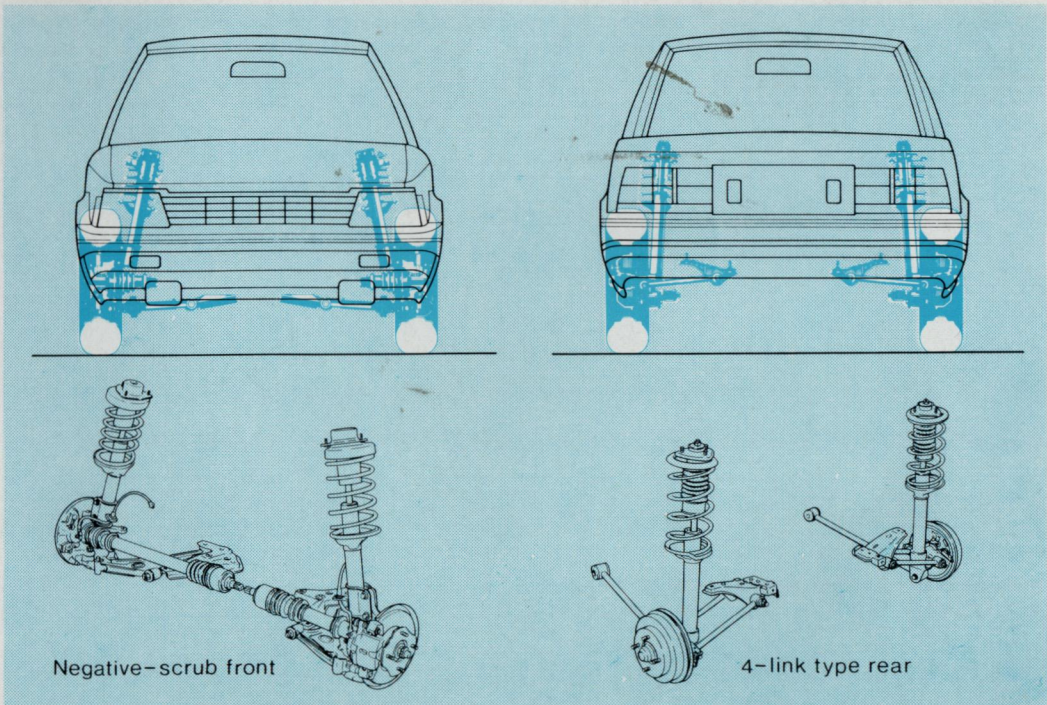

Advanced 4-wheel independent suspension

DATSUN STANZA SPECIFICATIONS

	3 door Hatchback	4 door Saloon	5 door Hatchback	
ENGINE:	All models, cross-flow, 4 cylinder in line, overhead camshaft, watercooled			
Type				
Capacity (cc)	1598	1598	1598	1809
Max power bhp/rpm (DIN)	81/5200	81/5200	81/5200	88/5200
Max torque lbs/ft (DIN)	95/3200	95/3200	95/3200	108/3200
Carburettor	All models 2 barrel downdraught, automatic choke			
TRANSMISSION:	5 speed manual, all synchromesh			3 speed, fully automatic
Type				
Gear ratios: 1st:	3.333			2.826
2nd:	1.955			1.543
3rd:	1.286			1.000
4th:	0.902			—
5th:	0.733			—
Reverse:	3.417			2.364
STEERING: Type:	All models rack and pinion, 3.6 turns lock to lock		Power assisted on SGL models	
SUSPENSION: Type:	All models 4-wheel independent MacPherson strut with transverse front arms and parallel rear links			
BRAKES: Type:	All models ventilated disc front, drum rear, power assisted. Automatic rear shoe adjuster			
WHEELS/TYRES:	All models 5J x 13 inch/165 SR 13 radials			
Wheel type GL (SGL)	Styled (Alloy)	Styled	Styled (Alloy)	(Alloy)
KERB WEIGHT (lbs) GL (SGL)	2083 (2105)	2051	2094 (2116)	(2172)
TOWING CAPACITY (with brake) lbs	All models 2425			
FUEL TANK CAPACITY Imp. galls.	All models 11.9			
GOVERNMENT FUEL CONSUMPTION TESTS – MPG (litres/100 kilometres)				
Constant 56 mph (90km/h)	51.4 (5.5)	47.1 (6.0)	48.7 (5.8)	40.4 (7.0)
Town Driving Cycle	29.1 (9.7)	29.1 (9.7)	29.1 (9.7)	28.2 (10.0)
Constant 75 mph (120km/h)	38.2 (7.4)	35.3 (8.0)	37.7 (7.5)	32.1 (8.8)

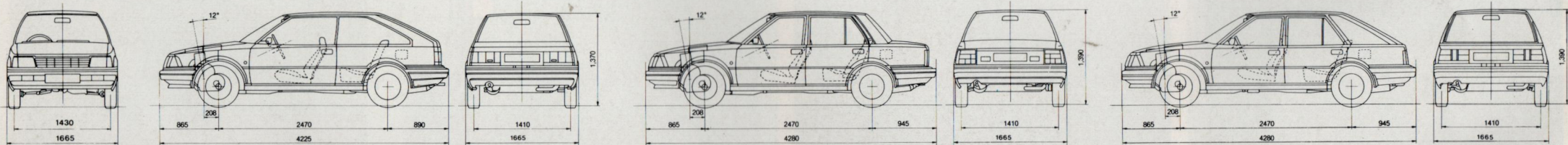

NISSAN / DATSUN

DATSUN UK LIMITED

Datsun House · New Road · Worthing
West Sussex BN13 3HD

Datsun policy is one of continuous improvement. The right is reserved to change specifications, colours and prices of the models and items illustrated and described in this publication at any time. Where possible, any such changes which may be introduced after publication of this booklet but before it is supplied will be incorporated herein or announced by means of a notice prominently displayed in Datsun Dealership at the point of supply. For the latest details always consult your Datsun Dealer.

Designed and Printed by:
Datsun U.K. Ltd at Worthing

S24.60m.E110.1.83