

GRADES

Here is where you can start to create your ideal Almera. Select one of the three body styles. Decide on one of the four engines. Choose the grade with the equipment you want.

Then imagine which of the ten colours would look best on your Almera. As always with the Almera, you have control.

S

3, 4, 5 DOOR

SAFETY

- Driver's and passenger airbags
- Panoramic driver's door mirror
- 3-point ELR seatbelts front and rear
- Front seatbelts with load limiter and pretensioner
- Three adjustable rear headrests
- 3 point rear centre seatbelt

COMFORT AND CONVENIENCE

- 4 spoke steering wheel
- Power steering (engine speed dependent)
- Tilt steering wheel adjustment
- Front power windows with one touch (driver's only)
- Logic cabin lighting
- Interior lamp
- Front cigar lighter
- Low fuel warning lamp
- Headlamp on warning buzzer
- Door ajar warning lamp
- Front cupholder
- Convenience hook
- Luggage area net

HEATING, VENTILATION AND VISIBILITY

- Air conditioning
- Pollen filter
- Two speed wiper with variable intermittent
- Rear wiper with intermittent (3 & 5 door only)

SEATING, TRIM AND STORAGE

- Vulcan seat fabric
- Driver and passenger front seat back pocket
- Driver's seat recline and lift adjustment
- 60/40 rear seat split
- Door pockets

SECURITY

- Central Locking with anti-hijack feature
- Keyless entry with superlocking
- Software lock immobiliser
- Audio linked to immobiliser

STYLING

- Body coloured bumpers
- Black side guard moulding
- Black door mirrors, door handles and bumper inserts
- 15" steel wheels with wheel covers (185/65/R15 tyres)

IN-CAR ENTERTAINMENT

- CD radio with 6 speakers

OPTIONS AT EXTRA COST

- Safety pack: ABS with EBD and brake assist, front side airbags and front active headrests

GRADES

Here is where you can start to create your ideal Almera. Select one of the three body styles. Decide on one of the four engines. Choose the grade with the equipment you want.

Then imagine which of the ten colours would look best on your Almera. As always with the Almera, you have control.



SE

3, 4, 5 DOOR
(as S PLUS)

SAFETY

- Front seat mounted side airbags
- Active front headrests
- ABS with Brake Assist
- Electronic Brake force Distribution (EBD)

TECHNOLOGY

- 5.8" monochrome centre display monitor
- Drive computer
- Ultrasonic Rear Park System

COMFORT AND CONVENIENCE

- Rear power windows (4 & 5 door only)
- Electrically adjustable door mirrors
- Front map reading lamp
- Outside temperature gauge

HEATING, VENTILATION AND VISIBILITY

- Climate control air conditioning

SEATING, TRIM AND STORAGE

- Tungsten seat fabric
- Satin chromed interior door handles
- Sunglasses holder
- Rear seat arm rest

STYLING

- Body coloured door mirrors, door handles and bumper inserts

IN-CAR ENTERTAINMENT

- Steering wheel mounted audio controls

OPTIONS AT EXTRA COST

- Electric tilt and slide sunroof (3 & 5 door only)

SVE

3, 5 DOOR
(as SE PLUS)

SAFETY

- Front fog lamps

TECHNOLOGY

- 7" colour centre display monitor with DVD satellite navigation

COMFORT AND CONVENIENCE

- 4 spoke leather steering wheel
- Electric tilt and slide sunroof

STYLING

- 16" alloy wheels (195/55/R16 tyres)

SXE

3, 5 DOOR
(as SE PLUS)

SAFETY

- Front fog lamps

TECHNOLOGY

- 7" colour centre display monitor with DVD satellite navigation
- Electronic Stability Program (ESP)
- Minus - Ultrasonic Rear Park System (NA for SXE)

COMFORT AND CONVENIENCE

- 4 spoke leather steering wheel

SEATING, TRIM AND STORAGE

- Graphite seat fabric

STYLING

- 16" alloy wheels (195/55/R16 tyres)
- Body-coloured side guard moulding and side sill spoiler
- Rear roof spoiler
- Chrome exhaust finisher

OPTIONS AT EXTRA COST

- Electric tilt and slide sunroof



Arctic White **S**



Flame Red **S**



Silica **P**



Catalpa Green **M**



Techno Grey **M**



Merlot **P**



Blade **M**



Pearl Black **M**

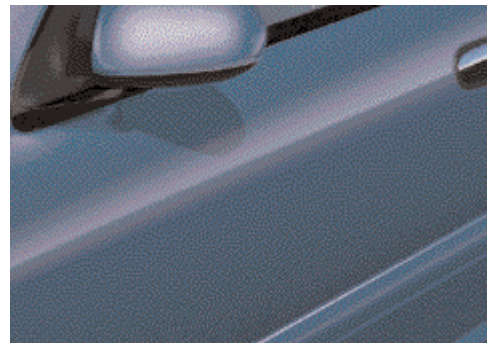

Aruba Blue **M**



Quartz Blue **M**

- S** solid
- M** metallic
- P** pearl metallic

COLOURS

DIMENSIONS

4-door saloon

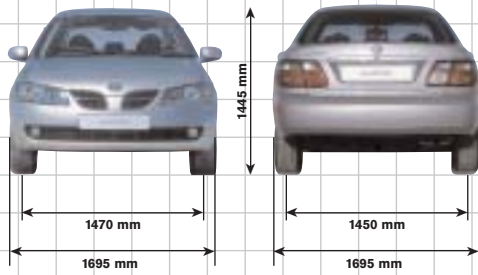

3 and 5-door hatchback

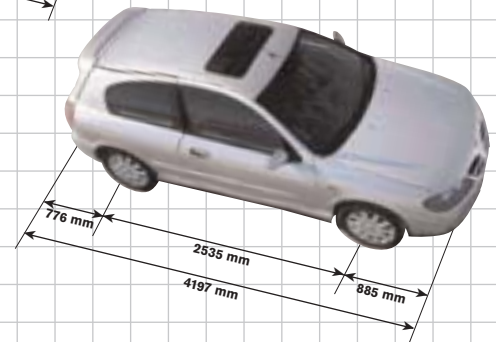
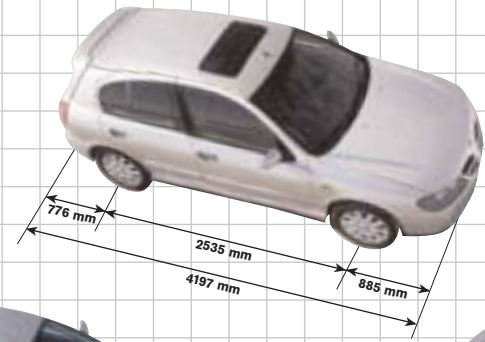
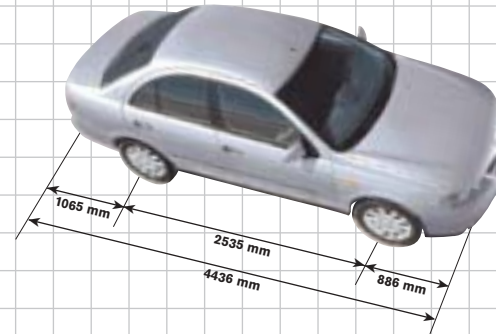
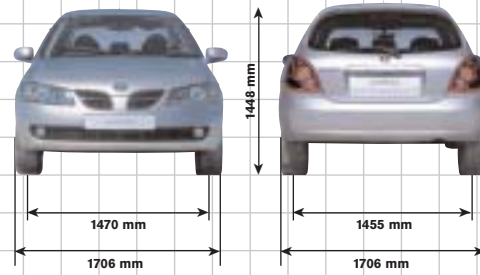

UPHOLSTERY

- S** solid
- M** metallic
- P** pearl metallic

Body Colour		S	SE	SVE*	SXE**
326	Arctic White S	•	•	•	•
Z10	Flame Red S	•	•	•	•
Z11	Pearl Black M	•	•	•	•
KY0	Blade M	•	•	•	•
AX5	Merlot P	•	•	•	•
BY4	Quartz Blue M	•	•	•	•
EY2	Silica P	•	•	•	•
KY5	Techno Grey M	•	•	•	•
D14	Catalpa Green M	•	•	•	•
BW6	Aruba Blue M	•	•	•	•

* 3 or 5 door only
 ** SXE available March 2003 (3 or 5 door only).

Graphite (SXE)

Vulcan (S)

Tungsten (SE & SVE)

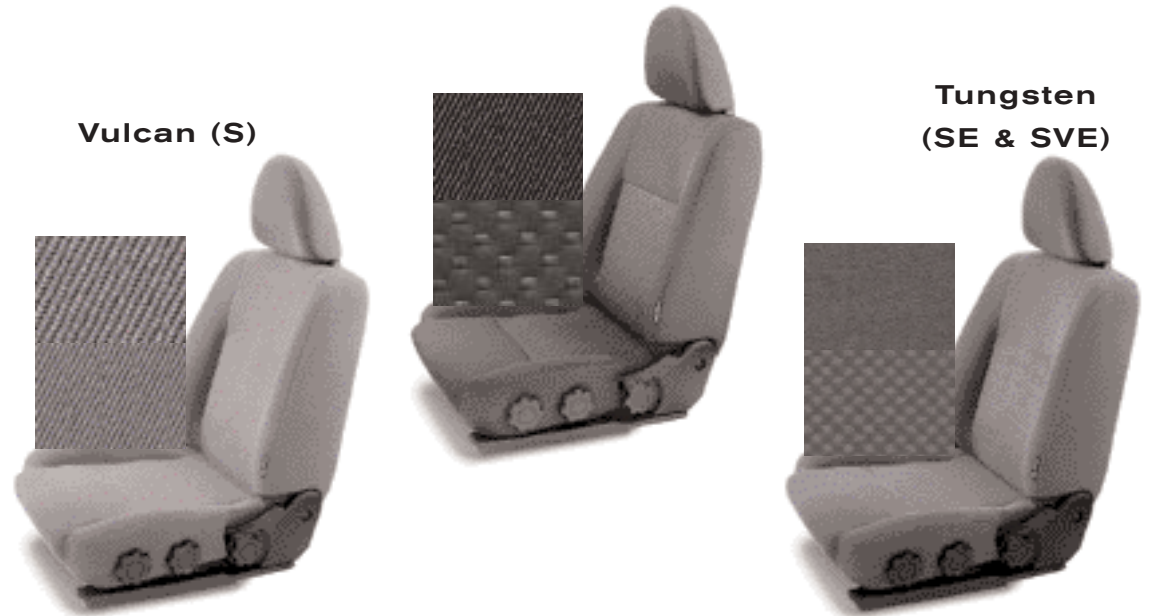

TECHNICAL SPECIFICATIONS

Model		1.5 litre petrol engine			1.8 litre petrol engine				
		3 door hatchback	4 door saloon	5 door hatchback	3 door hatchback	4 door saloon	5 door hatchback		
Available grades		5-speed manual 4-speed automatic	S, SE, SVE	S, SE	S, SE, SVE	SE, SVE, SXE S,SE, SVE	SE S, SE	SE, SVE, SXE S,SE, SVE	
Seating capacity		5 passengers			5 passengers				
ENGINE									
No. cylinders, configuration		4, in line							
Valves per cylinder / engine		4 / 16							
Engine capacity		1497			1769				
Bore x stroke		73.6 x 88.0			80.0 x 88.0				
Max. engine power ¹⁾		72 (97.9) x 6000			85 (116) / 5600				
Max. torque ¹⁾		136 / 4000			163 / 4000				
Fuel type		Unleaded petrol RON 95							
Ignition system / Intake system (Diesel)		Electronic, direct injection							
Fuel supply		Multipoint injection							
Emission control system		3-stage catalyst							
Emission level		E3							
DRIVE TRAIN									
Clutch type (auto)		Dry plate, Mechanical			Dry plate, Mechanical (Hydraulic torque converter)				
Transmission (auto)		5-speed manual			5-speed manual (4-speed automatic)				
Gear ratio	1st (auto)	3.3333			3.3333 (2.8611)				
	2nd (auto)	1.7826			1.9545 (1.5622)				
	3rd (auto)	1.2069			1.2857 (1.0000)				
	4th (auto)	0.9024			0.9268 (0.6979)				
	5th (auto)	0.7556			0.7333 (NA)				
	6th	-			-				
	Reverse	3.4167			3.2143 (2.3103)				
Final drive ratio		4.1667			4.4375 (4.0721)				
CHASSIS									
Suspension front		Independent, Mac Pherson Strut, Coil Springs							
Suspension rear		Multi Link Beam, Coil Springs							
Steering		Rack and pinion, Power Assisted							
Braking system (with ABS)		Two circuits, diagonal distribution, power assisted (Electronic 4 channel / 4 sensor ABS incl. EBD (Electronic Brake force Distribution), Brake Assist)							
		Front 257mm / 22mm disc			280mm x 22mm ventilated disc				
		Rear (with ABS) Drum (258mm x 10mm disc)			258mm x 10mm disc				
Wheel size min. / max. ²⁾		15 x 6 JJ / 16 X 6 JJ							
Tyre size min. / max.		185/65/R15 / 195/55R16							
WEIGHTS AND DIMENSIONS									
Kerb weight min. (auto) ³⁾		1170	1178	1179	1178 (1190)	1187 (1198)	1187 (1199)		
Kerb weight max. (auto) ³⁾		1245	1233	1254	1253 (1263)	1241 (1252)	1262 (1273)		
Gross Vehicle Weight (auto)		1710	1690	1710	1735	1735	1735		
Max. axle weight front / rear		925 / 970	890 / 950	925 / 970	955 / 970	920 / 970	955 / 970		
Max. trailer weight braked / unbraked		1000 / 600	1000 / 550	1000 / 600	1200 / 650	1200 / 650	1200 / 650		
Max. roof load		75							
Luggage space	max. length	812	980	812	812	980	812		
	max. width	1062	800	1062	1062	800	1062		
Luggage capacity (VDA)		355	460	355	355	460	355		
Fuel tank capacity		60							
PERFORMANCE									
Fuel consumption ⁴⁾	Urban cycle	l/100 km (mpg)	8.7 (32.5)			10.2 (27.7)		10.4 (27.2)	10.2 (27.7)
		(auto)	-			-		10.6 (26.6)	-
	Extra-urban	l/100 km (mpg)	5.5 (51.4)			5.9 (47.9)		6.0 (47.1)	5.9 (47.9)
		(auto)	-			-		6.2 (45.6)	-
	Combined	l/100 km (mpg)	6.7 (42.2)			7.5 (37.7)		7.6 (37.2)	7.5 (37.7)
		(auto)	-			-		7.8 (36.2)	-
CO ₂ mass emission		g/km			180		183	180	
		(auto)			-		187	-	
Max. speed		km/h (mph)			177 (110)		186 (115)		
		(auto)			-		176 (110)		
Acceleration 0-100 km/h (0-62 mph)		sec			13.1		10.8		
		(auto)			-		12.5		
Min. turning circle (kerb to kerb)		10.4							

1) In accordance with 1999/99/EC.

2) 15" spare steel wheel on all manual models. Automatic models come with a space saver spare wheel.

3) Figures in accordance with EC directive. Kerb weight condition is without Driver and including coolant, oils, fuel, spare wheel & tools.

Pay load will be reduced depending on the options and / or accessories installed.

4) In accordance with 1999/100/EC. (Optional equipment, maintenance, driving technique, road and weather conditions may affect the official results).

5) Available from April 2003

6) Available from March 2003

TECHNICAL SPECIFICATIONS

Model		2.2 litre dCi 112 engine ⁹⁾			2.2 litre dCi 136 engine ⁹⁾				
		3 door hatchback	4 door saloon	5 door hatchback	3 door hatchback	4 door saloon	5 door hatchback		
Available grades		5-speed manual SE, SVE	5-speed manual SE	5-speed manual SE, SVE	5-speed manual SXE	5-speed manual -	5-speed manual SXE		
Seating capacity		4-speed automatic persons	5 passengers			5 passengers			
ENGINE									
No. cylinders, configuration		4, in line							
Valves per cylinder / engine		4 / 16							
Engine capacity		cm ³ 2184							
Bore x stroke		mm 86.0 x 94.0							
Max. engine power ¹⁾		kW(PS)/rpm 82 (112) x 4000			100 (136) / 4000				
Max. torque ¹⁾		Nm/rpm 248 / 2000			304 / 2000				
Fuel type		Diesel							
Ignition system / Intake system (Diesel)		Compression							
Fuel supply		Direct injection, common rail							
Emission control system		EGR + catalyst							
Emission level		E3							
DRIVE TRAIN									
Clutch type (auto)		Dry plate, Mechanical			Dry plate, Mechanical				
Transmission (auto)		5-speed manual			6-speed manual				
Front wheel driven									
Gear ratio	1st (auto)	3.4000			3.4160				
	2nd (auto)	1.9550			1.9440				
	3rd (auto)	1.2060			1.2580				
	4th (auto)	0.8290			0.9020				
	5th (auto)	0.6410			0.6730				
	6th	-			0.5400				
	Reverse	3.4270			3.2520				
Final drive ratio		3.8230			3.8120				
CHASSIS									
Suspension front		Independent, Mac Pherson Strut, Coil Springs							
Suspension rear		Multi Link Beam, Coil Springs							
Steering		Rack and pinion, Power Assisted							
Braking system (with ABS)		Two circuits, diagonal distributor, power assisted (Electronic 4 channel / 4 sensor ABS incl. EBD (Electronic Brake force Distribution), Brake Assist)							
Front		280mm x 22mm ventilated disc							
Rear (with ABS)		258mm x 10mm disc							
Wheel size min. / max. ²⁾		15 x 6 JJ / 16 x 6 JJ							
Tyre size min. / max.		185/65/R15 / 195/55R16							
WEIGHTS AND DIMENSIONS									
Kerb weight min. (auto) ³⁾		kg	1273	1302	1298	1288	1306	1304	
Kerb weight max. (auto) ³⁾		kg	1337	1347	1364	1356	1355	1373	
Gross Vehicle Weight (auto)		kg	1810	1800	1810	1810	1800	1810	
Max. axle weight front / rear		kg	1010 / 945		1010 / 970		1010/845		
Max. trailer weight braked / unbraked		kg				1200 / 650		1010 / 970	
Max. roof load		kg	75						
Luggage space	max. length	mm	812	980	812	812	980	812	
	max. width	mm	1062	800	1062	1062	800	1062	
Luggage capacity (VDA)		l	355	460	355	355	460	355	
Fuel tank capacity		l	60						
PERFORMANCE									
Fuel consumption ⁴⁾	Urban cycle	l/100 km (mpg)	8.0 (35.3)			7.9 (35.8)			
		(auto)	-			-			
	Extra-urban	l/100 km (mpg)	4.7 (60.1)			4.8 (58.8)			
		(auto)	-			-			
	Combined	l/100 km (mpg)	5.9 (47.9)			5.9 (47.9)			
		(auto)	-			-			
CO ₂ mass emission		g/km	161			161			
(auto)		g/km	-			-			
Max. speed	km/h (mph)	187 (116)			200 (124)				
	(auto)	-			-				
Acceleration 0-100 km/h (0-62 mph)		sec	11.4			9.2			
(auto)		sec	-			-			
Min. turning circle (kerb to kerb)		m	10.4						

1) In accordance with 1999/99/EC.

2) 15" spare steel wheel on all manual models. Automatic models come with a space saver spare wheel.

3) Figures in accordance with EC directive. Kerb weight condition is without Driver and including coolant, oils, fuel, spare wheel & tools.

Pay load will be reduced depending on the options and / or accessories installed.

4) In accordance with 1999/100/EC. (Optional equipment, maintenance, driving technique, road and weather conditions may affect the official results).

5) Available from April 2003.

6) Available from March 2003.

NISSAN COMMITMENT

This Agreement is the subject matter of this Agreement. All proprietary rights in by product created by modification, amendment or Agreement shall be binding on the manufacturer. Nissan reserves the right to modify this Agreement without notice.

Ownership

The Nissan philosophy of continuous improvement means we have a different approach to building cars. To make sure that every Nissan meets the real-life needs of its owner, we ask current Nissan drivers what they think of their cars before we start designing. Then there's our tough testing programme. To maintain our excellent reputation for reliability, dependability and safety, we test every single component to destruction. Finally, as the car is assembled, every worker checks his own job as well as that of the person before, ensuring our renowned standards of build quality and attention to detail.

KEEPING THINGS LOCAL

Nissan is committed to keeping its European operations on a local basis. There's a design centre in Germany. Technology Centres in Britain, Spain and Belgium. Manufacturing plants in Britain and Spain. Parts and vehicle distribution in the Netherlands. And our European headquarters in France. Because only through this structure can we continue to produce vehicles to suit the requirements of the people who'll actually drive them. And guarantee that somewhere, within our wide range of models available in Europe, there is one perfect for you.

AFTER-SALES SUPPORT

Our rigorous testing programme gives us the confidence to offer a comprehensive range of after-sales guarantees. All Nissan cars are covered by a 3-year or 60,000 miles warranty (whichever comes first), 3-year paint warranty and 12-year anti-corrosion warranty. For extra peace of mind, we also offer a 12-month RAC roadside assistance package.