



SRX

DARING, HEAD-TURNING STYLING WITH BOLD, CHISELED LINES AND A CONFIDENT STATURE.

UTILITY THAT IS NOTHING SHORT OF INGENIOUS.

A PERFORMANCE CALCULATED TO EXCITE EVEN THE MOST DEMANDING DRIVER,  
REFINED AT FIVE DIFFERENT RACETRACKS, INCLUDING GERMANY'S FAMED NÜRBURGRING.

THE ALL-NEW SRX – A TRUE LUXURY CROSSOVER WITH THE HEART OF A SPORT SEDAN.











**YOU CHOOSE THE DIRECTION**









## LET THE SUNSHINE IN

With its sheer, straightforward exterior lines the SRX delivers remarkable functionality in a package that quickens the pulse – and opens horizons. Because part of the most original and striking design to grace the luxury cross-over segment yet is the thrill of an open-air experience provided by the largest sunroof opening available in this class.



## **A DIFFERENT POINT OF VIEW**

Offering daring styling, dynamic performance and flexible utility all in one vehicle, the SRX takes a whole new look at the segment, bridging the gap between a luxury performance sedan and a full-size SUV. Its long wheelbase and a low center of gravity deliver excellent handling and impressive balance, while still providing a strong commanding view of the road.











## **BUILT BY AND FOR THE OPEN-MINDED**

The SRX proves that utility and luxury get along quite well. With its elevated, but not too elevated, seating position, the driver experiences a commanding view of the road. Tiered theater seating extends this view for the passengers. The second row, offering the most legroom in this class, is about 5 cm higher than the front, and the third row is 12 cm higher still than the second.

Offering open-air driving for the first and second-row occupants, the optional UltraView sunroof with solar glass provides a sense of openness and exhilaration that is far beyond anything previously experienced in a vehicle. In addition to this, the UltraView Plus sunroof is also available.







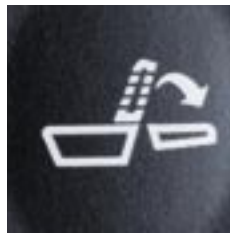

PUSH THE BUTTON AND THE OPTIONAL POWER-FOLDING THIRD-ROW SEAT STOWS FLAT INTO THE REAR FLOOR OR RISES INTO POSITION.





## ROOM TO MOVE

Comfortable 50-cm-long front seats are standard on the SRX. This executive accommodation also includes the best-in-class second-row legroom. The second-row seats fold forward easily, creating a flat floor and 1,968 l of cargo space. Behind the second row, you can choose your own flavor of flexible utility, with two optional features preserving the flat-load floor. One is an ingenious power-folding third-row seat that brings seating up to seven. The other is an innovative cargo management system with three large compartments.





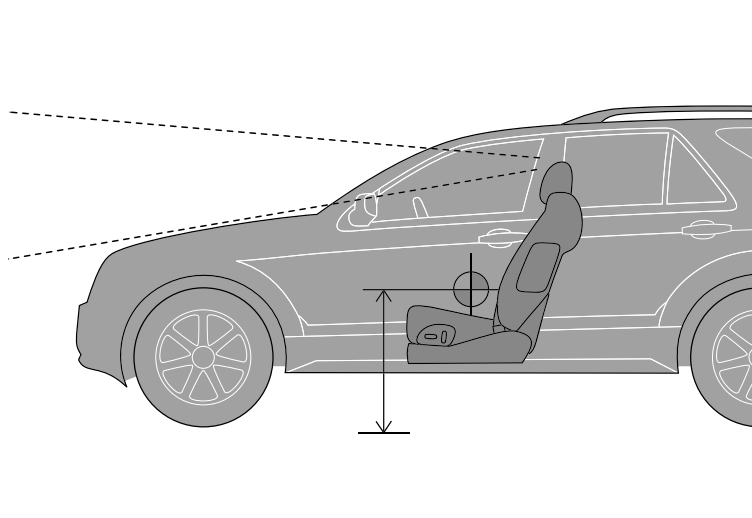

THE SRX HAS A HIGHER DRIVING POSITION  
TO DELIVER A COMMANDING VIEW OF THE ROAD,  
WITHOUT COMPROMISING DYNAMIC HANDLING.

## THAT WILL SUIT YOU PERFECTLY

Driver and front passenger seating in the SRX has been developed to accommodate a wide range of body types and sizes. The design offers excellent support for long drives. Distinguished by a high center stack, all information is clearly displayed; controls are convenient, ergonomic, and within easy reach. Steering wheel controls are placed for intuitive operation. Driver Shift Control (DSC) allows you to switch from full automatic to a clutchless 5-speed manual operation. With the shifter on the right side of the gate, a simple tap provides performance shifting.



RPM  
x 1000

KMH

96 km/h



MEET

1-6

+

+

-

-





## EVERYTHING UNDER CONTROL

Once you're behind the wheel of an SRX you immediately sense how well-thought-out everything in this unique new vehicle is. It starts with memory and personalization, a feature that automatically resets seat adjustments, adjustable brake and accelerator pedal positions, outside mirrors, and many more additional personalization features for two individual drivers.

The available DVD navigation system with voice recognition keeps a nearly limitless supply of easy-to-follow directions at your fingertips, and can even play movies when the SRX is parked. A standard information and entertainment system provides on-board diagnostics, AM/FM radio with seven-speaker audio system, and an in-dash 6-disc CD changer.

## A VERY FINE SELECTION

Jewel-like accents and leather-trimmed seating surfaces and armrests on the first and second-row seats prove that utility and luxury get along very well.

Burled walnut trim lends the warmth of wood to the shifter knob, trim plate, and door pulls. Speaking of warmth, for ultimate comfort the SRX also contains a world-class heating, ventilation, and air-conditioning system. It can also provide rapid cool-down times even with the optional UltraView sunroof, and the rear air-conditioning system for the second and third-row passengers has its own evaporator and blower motor.













## **FAMILY ENTERTAINMENT**

Theater seating ensures that everybody in the SRX has a good view, allowing your third-row riders to enjoy the available second-row DVD screen. It features an 18-cm flip-up color liquid crystal display (LCD) that is optimally positioned for second and third-row viewing. It includes two infrared headsets, auxiliary inputs for video games, camcorders, etc., remote control and independent audio selection for endless multimedia enjoyment.











## BRAIN POWER

Looking for exhilarating performance from idle to top-end? Make your choice from the two responsive engines available for the SRX. The 32-valve 4.6-liter V8 VVT produces performance-car levels of horsepower (239 kW/325 hp) and torque (425.3 Nm @ 4,400 rpm). This accomplishment is not so much a matter of engine size as it is a product of brains. Specifically, a highly advanced variable-valve timing system that manages the exhaust as well as the intake camshafts. Precise management of the ins and outs of combustion provides optimum levels of both horsepower and torque across a remarkably broad range of engine speeds. The 24-valve 3.6-liter V6 VVT produces 194 kW/258 hp and a torque of 340.2 Nm @ 2,800 rpm. Both engines are mated to a 5-speed Hydra-Matic transmission with a sophisticated control system that analyzes both your driving style and the current situation to select the optimal gear. And for times when you wish to be more directly involved, just slip the transmission via Driver Shift Control mode into clutchless manual operation. Because there's still no substitute for fun.







## INNER STRENGTH

With its body and frame engineered as a single unit, the SRX architecture forms a rigid, efficient foundation for sporty performance. So when you put the SRX in motion, what it tends to do is exactly what you want it to do. Its all-wheel drive configuration helps to achieve a near-50/50 front/rear weight distribution. Integrated into this solid base is a host of advanced driving technologies, such as StabiliTrak, a four-channel stability enhancement system that compares driver steering with vehicle response and manages vehicle systems as needed—to help keep you moving in the direction you intend, even in the poorest traction situations. Magnetic Ride Control, the world's fastest-reacting suspension system, is also available for the SRX.

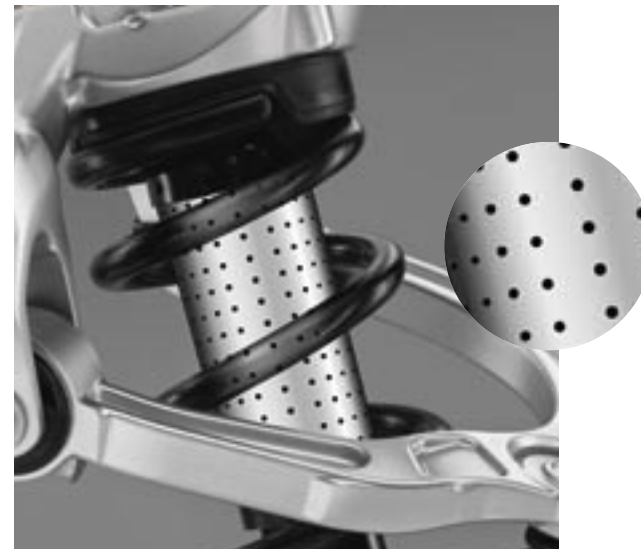
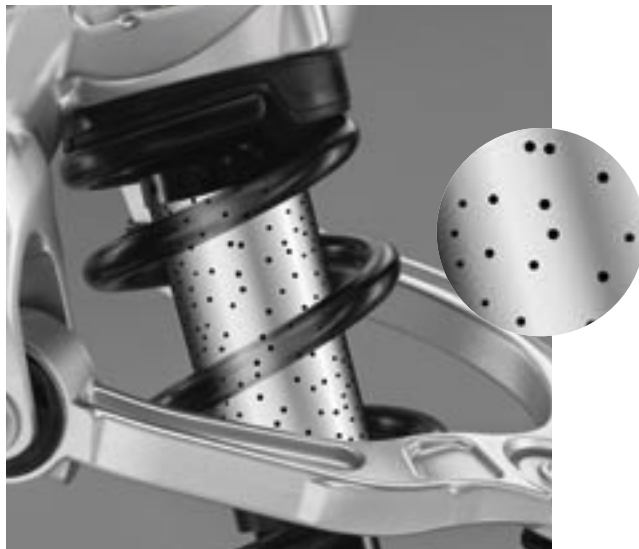

THE SECRET TO MAGNETIC RIDE CONTROL'S RAPID REACTION TO CHANGING ROAD CONDITIONS IS A UNIQUE SHOCK ABSORBER FLUID WITH METAL PARTICLES. IN NORMAL CONDITIONS, THE FLUID FLOWS EASILY FOR A COMFORTABLE RIDE. IN RESPONSE TO ELECTRONIC SIGNALS, A MAGNETIC FIELD ALIGNS THE PARTICLES TO FORM A STRUCTURE FOR INCREASED RESISTANCE DURING DRIVING MANEUVERS OR IN RESPONSE TO ROAD INPUT.







 FRONTAL DUAL-STAGE AIR BAG

 SEAT-MOUNTED SIDE-IMPACT AIR BAGS

 HEAD CURTAIN AIR BAGS

## **A REAL GOOD FEELING**

Beneath such self-evident things as ABS and front and rear crumple zones, there is also the reassuring presence of six air bags: frontal dual-stage and seat-mounted side-impact air bags for the driver and front-seat passenger, plus front and second-row head curtain air bags. And with advanced chassis features such as all-speed traction control the SRX offers smooth, agile performance and confident control on a variety of surfaces.

## BUILT-IN TECHNOLOGY FOR ALL SEASONS

The SRX all-wheel drive focuses mechanical simplicity and advanced technology on a comprehensive design goal: to help optimize control, regardless of changes in road conditions or weather. In challenging traction situations, the chassis system selectively applies individual brakes – and, if necessary, modulates engine torque – to channel power to the wheel or wheels with the greatest traction potential. The system operates smoothly in the background, allowing you to continue driving the way you want. The aspect you are likely to value most is the finesse the system applies in transition zones (dry to icy, for instance) where getting the traction required is most difficult and most desirable.

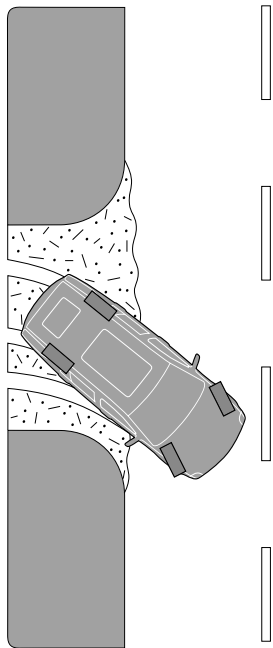

THE BUTTON ON THE CONSOLE ALLOWS YOU TO TURN OFF TRACTION CONTROL FOR INCREASED WHEELSPIN IN DRIVING SITUATIONS SUCH AS DEEP SNOW, WHILE STILL MAINTAINING THE DIRECTIONAL BENEFITS OF STABILITRAK.







## ELEGANCE IN MOTION

For those whose lifestyles demand the highest degree of utility, the SRX is the right answer. Which other vehicle can be converted from seven-passenger comfort to a flat-load floor without removing heavy seats? Which other vehicle combines dynamic performance and handling, breakthrough styling and utility in such an ingenious way? The SRX – a unique offer. From Cadillac.













## WHAT'S YOUR POINT OF VIEW?

Find out what the SRX can do for your lifestyle. See your local Cadillac retailer for more information and a convincing test drive in this amazing new crossover from Cadillac.







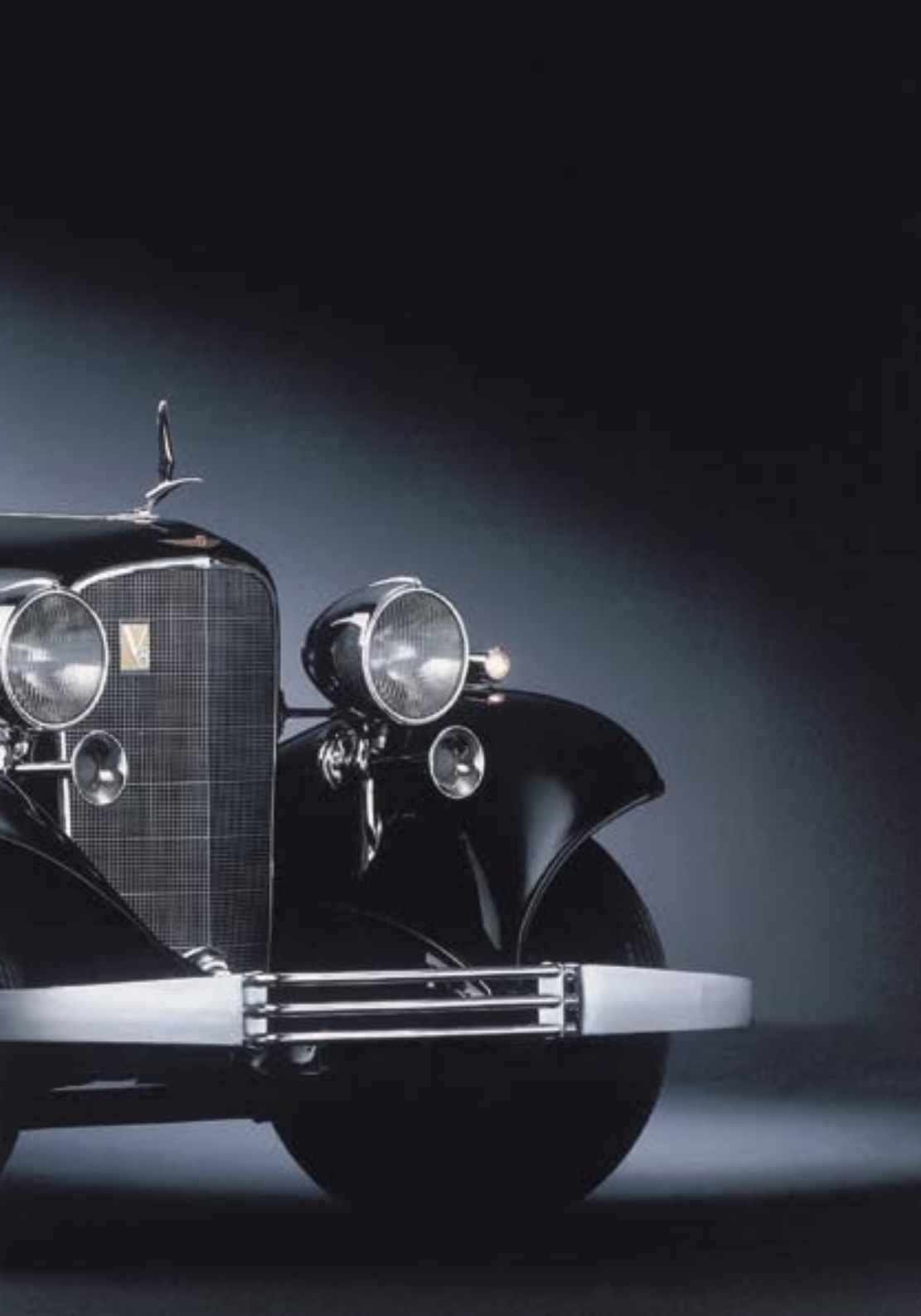

## CARS THAT MADE HISTORY

From 1902 onwards, Cadillac grew its reputation on quality, performance, and innovation. Guided by strict design principles Cadillacs always have been a conscious leap into the future. An emergence of a vision that elevated Cadillac's global status as one of the true luxury brands.

Even as Cadillac designers now envision the future with new products, they embrace the underlying spirit that has guided Cadillac's notable achievements: a commitment to apply superior designs and sophisticated technologies to the automobile. This marriage of design and innovation is at the core of Cadillac's product portfolio.



[www.cadillaceurope.com](http://www.cadillaceurope.com)

Every Cadillac carries a 3-year or 100,000-km (whichever comes first) guarantee. It has a 6-year anticorrosion guarantee. Cadillac Assistance gives you reassurance for a period of 36 months starting on the registration date. 24 hours a day, 365 days a year. Some illustrations in this brochure feature special equipment that is not included in standard delivery. Errors and alterations accepted! All information correct at the time of publication. We reserve the right to make changes in design and equipment. The colors printed in the brochure only approximate actual colors. Illustrated optional equipment is available at extra charge. Availability, technical features and equipment provided on our vehicles can vary from one market to another and may change without prior notice. Information on recycling design, recycling End of Life Vehicles (ELV) and the return locations of ELVs can be found on the website [www.cadillaceurope.com](http://www.cadillaceurope.com). For precise information on the equipment provided on our vehicles, please contact your Cadillac retailer.



SRX

TECHNICAL SPECIFICATIONS







### CAPACITIES AND DIMENSIONS

Overall length (mm)	4,950
Overall width (mm)	1,845
Overall height with/without roof rails (mm)	1,721/1,685
Wheelbase (mm)	2,957
Minimum ground clearance (mm)	185
Track width (mm) front/rear	1,566/1,568
Seating capacity (1st/2nd/3rd row)	2/3/2 (3rd row optional)
Headroom front (mm)	1,024
Headroom 2nd row (mm)	975
Headroom optional 3rd row (mm)	889
Legroom front (mm)	1,069
Legroom 2nd row (mm)	1,041
Legroom optional 3rd row (mm)	615
Cargo volume behind 1st row (l)	1,968
Cargo volume behind 2nd row (l)	918
Cargo volume behind 3rd row (l)	238
Curb weight V6 kg (min./max.)	1,996/2,094
Curb weight V8 kg (min./max.)	2,051/2,142
Maximum allowable weight (kg)	2,675
Fuel tank capacity (l)	76
Towing capacity braked (kg)	2,268
Towing capacity unbraked (kg)	750

### ENGINE AND TRANSMISSION

#### 3.6L V6

Engine (V6)	3.6L V6 VVT
Valve train	24
Drive system	Integrated full time 50/50 torque split, all-wheel drive
Engine block/cylinder heads	Cast aluminum/cast aluminum
Bore and stroke (mm)	94 x 85.6
Displacement (cc)	3,564
Compression ratio (:1)	10.2
Fuel feed system	Sequential multipoint injection
Fuel type	Unleaded gasoline min. 91 RON, rec. 95 RON
Performance (kW/hp/min-1)	190/258/6,500
Maximum torque (Nm/rpm)	339/2,800
Transmission	5-speed automatic with driver shift control
Top speed (kph)	201
Acceleration 0-100 kph (sec.)	8.1
Fuel consumption 99/100/EC (l/100 km urban/extra-urban/mix)	19.1/12.1/14.7
CO <sub>2</sub> emission (g/km)	349

### ENGINE AND TRANSMISSION

#### 4.6L V8

Engine (V8)	4.6L Northstar V8 VVT
Valve train	32
Drive system	Integrated full time 50/50 torque split, all-wheel drive
Engine block/cylinder heads	Cast aluminum/cast aluminum
Bore and stroke (mm)	93 x 84
Displacement (cc)	4,565
Compression ratio (:1)	10.5
Fuel feed system	Sequential multipoint injection
Fuel type	Unleaded gasoline min. 91 RON, rec. 95 RON
Performance (kW/hp/min-1)	239/325/6,500
Maximum torque (Nm/rpm)	427/4,400
Transmission	5-speed automatic transmission with driver shift control
Top speed (kph)	225
Acceleration 0-100 kph (sec.)	7.4
Fuel consumption 99/100/EC (l/100 km urban/extra-urban/mix)	19.1/10.9/14.0
CO <sub>2</sub> emission (g/km)	331

### CHASSIS AND SUSPENSION

#### V6 ELEGANCE

Front suspension	Front axle: short/long arm
Rear suspension	Rear axle: independent multilink design
Steering type	Rack-and-pinion with speed-sensitive power assistant
Wheels	17" x 7.5J cast aluminum painted
Tires (front/rear)	P235/65R17 / P255/60R17H-rated
Braking system	Ventilated discs, ABS

### CHASSIS AND SUSPENSION

#### V6/V8 SPORT LUXURY

Front suspension	Front axle: short/long arm, Magnetic Ride Control variable damping
Rear suspension	Rear axle: independent multilink design, Magnetic Ride Control variable damping
Steering type	Rack-and-pinion with speed-sensitive power assistant
Wheels	18" x 8J cast aluminum allbright finish
Tires (front/rear)	P235/60R18 / P255/55R18 V-rated
Braking system	Ventilated discs, ABS

STANDARD EQUIPMENT INTERIOR	V6 ELEGANCE	V6 SPORT LUXURY	V8 SPORT LUXURY
Dual zone climate control including rear air-conditioning controls	S	S	S
Theft-deterrent system, Passkey® III Plus	S	S	S
Keyless entry	S	S	S
8-way driver power seat and outside mirror memory package	S	S	S
8-way adjustable power passenger seat	-	S	S
Power adjustable pedals with memory	-	S	S
Power adjustable lumbar front seats	-	S	S
Leather interior	S	S	S
Heated front seats	-	S	S
2nd row seats adjustable 40/60 split	S	S	S
Steering wheel controls for sound system and climate control	S	S	S
Leather wrapped steering wheel	S	-	-
Leather wrapped steering wheel with burled walnut accents	-	S	S
Wood trim package	-	S	S
Automatic dimming rearview mirror	S	S	S
Power windows all express-down	S	S	S
Speed-sensitive power steering	S	S	S
AM/FM RDS stereo with in-dash 6-disc CD changer	S	S	S
Bose® premium 8-speaker system	S	S	S
Cargo net	S	S	S

#### STANDARD EQUIPMENT SAFETY

5-speed automatic transmission with all-wheel drive and driver shift control	S	S	S
Frontal dual stage and side thorax for driver and passenger airbag; head curtain for 1st and outboard 2nd row passengers	S	S	S
StabiliTrak™	S	S	S
4-wheel antilock disc brakes	S	S	S
Theft-deterrent alarm system	S	S	S
Tire pressure monitor	S	S	S

#### STANDARD EQUIPMENT EXTERIOR

Front fog lamps	S	S	S
Xenon headlamps	S	S	S
Automatic leveling system for the headlamps	S	S	S
Rear park assistant LED light bar and audible warning	S	S	S
Roof rails	S	S	S
4-wheel independent suspension	S	S	S
Magnetic Ride Control suspension	-	S	S
Traction control all-speed, brake and engine controlled	S	S	S
All-wheel drive	S	S	S
17" wheels, cast aluminum painted	S	-	-
P235/65R17 H-rated all-season front tires	S	-	-
P255/60R17 H-rated all-season rear tires	S	-	-
18" wheels cast aluminum with allbright finish	-	S	S
P235/60R18 V-rated all-season front tires	-	S	S
P255/55R18 V-rated all-season rear tires	-	S	S

#### OPTIONAL EQUIPMENT

Metallic paint	○	○	○
Rear seats entertainment system includes DVD player, LCD display, wireless headphones and remote control	-	○	○
UltraView, power glass sunroof opening over 1st and 2nd row, tilt sliding, with express-open and power sunshade	○	○	○
UltraView Plus, power glass sunroof opening over 1st and 2nd row, tilt sliding, with express-open, power sunshade and glass roof over 3rd row (only available with 3rd row seat option)	○	○	○
Rear compartment multistorage system (not available in combination with third row seats)	○	○	○
Third row seats, power foldable flat into load floor (not available in combination with rear compartment multistorage system)	○	○	○
Sound system, ETR AM/FM stereo with in-dash 6-disc CD changer from Bose®, DVD-based navigation system, digital signal processing and 8 speakers	-	○	○

S = standard  
○ = optional  
- = not available

## EXTERIOR

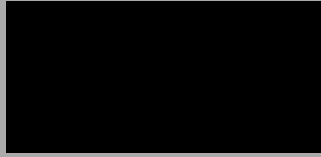

BLACK RAVEN

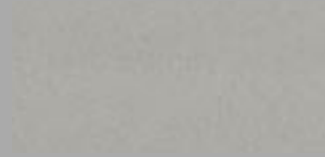

LIGHT PLATINUM\*

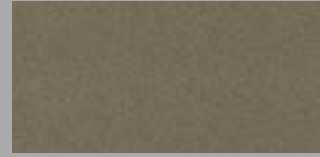

SAND STORM\*

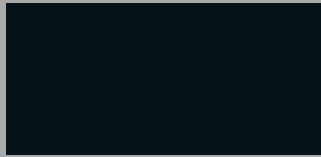

BLUE CHIP\*



SILVER GREEN\*



MOONSTONE\*



WHITE DIAMOND\*



RED LINE\*

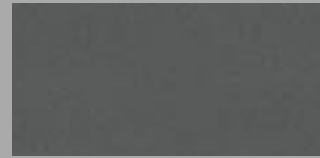

SILVER SMOKE\*

## INTERIOR



EBONY



LIGHT GRAY



LIGHT NEUTRAL

\*Metallic paint.



Every Cadillac purchased from an authorized retailer comes with General Motors warranty protection for the first three years or 100,000 km from the date of initial registration. All metal panels are guaranteed against rust-through perforation for 72 months, regardless of the number of kilometers driven. The General Motors customer protection system gives you around-the-clock Roadside Assistance 7 days a week, 365 days a year. For the latest updates of the technical specifications check [www.cadillaceurope.com](http://www.cadillaceurope.com).