

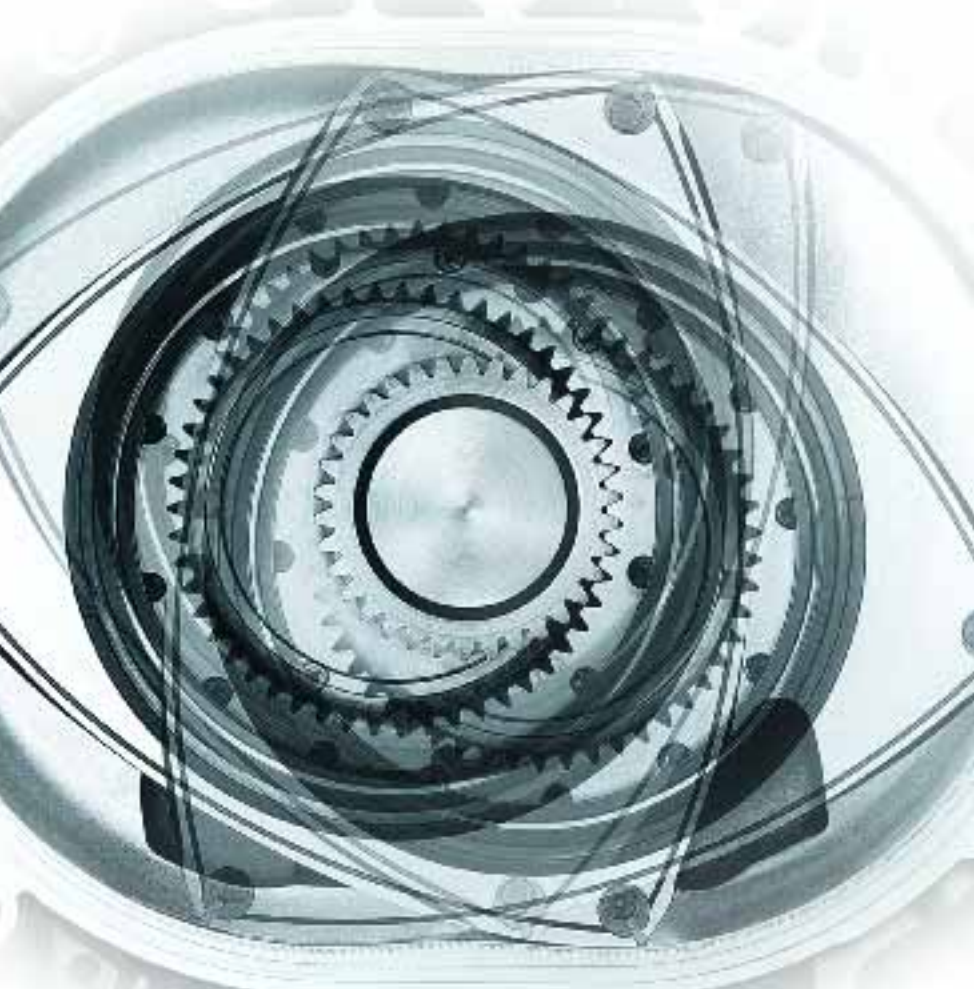

## Your personal Mazda RX-8 Configurator

Now that you have read about the Mazda RX-8, here's your opportunity to create the model that's just right for you.

Overleaf, you will find a series of checkboxes. Simply tick the derivative and features of your choice, and keep it as a quick reminder of your preferred model. Alternatively, show it to your Mazda dealer who will be happy to arrange a test drive so you can experience the thrilling Mazda RX-8 for yourself.



## The Mazda Warranties.

### Warranty Plus – 3-Year Cover

Every Mazda is designed and built to the highest standards of performance, comfort and reliability. For your further reassurance, Mazda also provides a full 3-year / 60,000 mile<sup>1</sup> warranty cover, including Mazda European Assistance, 3-year paintwork warranty and a 12-year anti-perforation warranty. <sup>1</sup>There is no mileage limit during the first year of the warranty.

### Mazda Momentum – New Vehicle Extended Warranty

At any time during the manufacturer's warranty period, you may purchase a Mazda Momentum extended warranty package. Three options are available. Your Mazda dealer will be pleased to provide you with details.

### Mazda Credit\*

Mazda offers a variety of finance, leasing and payment protection schemes to suit the needs of both private and business customers. With our wide choice of plans and services, no-one is more committed to delivering complete motoring confidence and total peace of mind than Mazda and Mazda Credit.

Mazda MultiOption – Economical payments protected by any fall in car values, with three options to choose from at the end of the agreement.

Mazda MultiOption Cashplan – All the benefits of MultiOption but with no regular payments.

Mazda Hire Purchase – A simple, straightforward and traditional funding plan.

### Mazda Business Partner

As a Mazda corporate customer, you'll find that Mazda vehicles are designed to fulfil the diverse needs of a modern company. Our corporate service offers attractive purchase prices, low running costs and market-driven residual values, resulting in extremely competitive ownership costs.

### Mazda Digital Service Record

The Mazda Digital Service Record (DSR) system provides increased security against counterfeit service documents and odometer tampering, and makes it easy to keep the service history up to date. Stored on a central database, the DSR replaces the traditional paper service book and ensures a secure, accurate and permanent service history for the life of the vehicle.

### Your Mazda dealer:

Mazda Motors UK Limited reserves the right to introduce changes in specification and equipment due to its ongoing product development. Colour and trim samples shown in this brochure may vary from the actual colours because of limitations in the printing process. It is recommended that you consult your Mazda dealer when referring to these.

\*Finance subject to status. Guarantees / Indemnities may be required. Written quotations: Mazda Credit UK, Central Office, Eagle Way, Brentwood, Essex CM13 3AR.

Authorised and regulated by the Financial Services Authority.

Bose®, the Bose logo, AudioPilot®, Nd®, Richbass® and Nd\*Richbass® are registered trademarks of Bose Corporation in the U.S. and other countries. Used with permission.

September 2007.

Internet: [www.mazda.co.uk](http://www.mazda.co.uk)  
Mazda Helpline: 08457 48 48 48



## Mazda RX-8



Part No. MCAG1067 09107 (BIN 304238IUKV1)

ZOOM-ZOOM





## 6 Performance revolution

The ultimate rotary engine: RENESIS.

## 14 A passion for design

Changing the shape of driving.

## 20 Pushing the boundaries

Spaciousness beyond the expected.

## 26 Freedom of choice

Models, trim levels, options and accessories.

## 30 The Mazda RX-8 in detail

Technical data, standard equipment, options, colour and trim.

Configurator.









*Intake*



*Compression*



*Ignition*



*Combustion*

# performance revolution

The revolutionary heart that beats inside the Mazda RX-8 began life nearly 80 years ago when a young man, Felix Wankel, had a dream that dared to challenge conventional wisdom. In 1961, Mazda took up the vision and launched a massive development programme into the rotary engine. From that day forward, Mazda has become the acknowledged world leader in rotary engine technology, culminating in the innovative RENESIS engine, which marks the latest chapter of the Mazda rotary engine story.

Unlike a conventional piston engine, the Mazda RX-8's rotary engine has no cylinders, pistons or valves. Instead, two triangular-shaped rotors spin within their oval housings around a common output shaft. As combustion occurs, each rotor instantly turns, and the revs increase rapidly with virtually no vibration. And with only three main moving parts, compared to a minimum of 40 in a piston engine, power delivery is incredibly smooth and refined. With this level of ingenuity, it's no wonder the Mazda RX-8 has won the International Engine of the Year award two years in a row.

There are two RENESIS engines to choose from: the potent 192ps (141kW) engine with a 5-speed manual transmission; and the exceptional 231ps (170kW) engine, coupled to a 6-speed manual transmission. Both engines deliver the kind of smooth acceleration and exhilarating power that will produce an adrenalin rush like you've never experienced before.



#### **The rotary combustion cycle.**

In a rotary engine, a triangular-shaped rotor sweeps the fuel/air mixture along, with each part of the combustion process occurring in a different section of the engine housing.

As an apex of the rotor passes the intake port, the fuel/air mixture is drawn in. The intake port is blocked and the mixture is compressed. This compressed fuel/air mixture is then ignited by four spark plugs (two for each rotor), ensuring maximum burn and maximum power. The force created by the combustion spins both the rotor and the driveshaft. The rotor's continuing orbit forces exhaust gases out the exhaust port, before the cycle begins again.

*Exhaust*

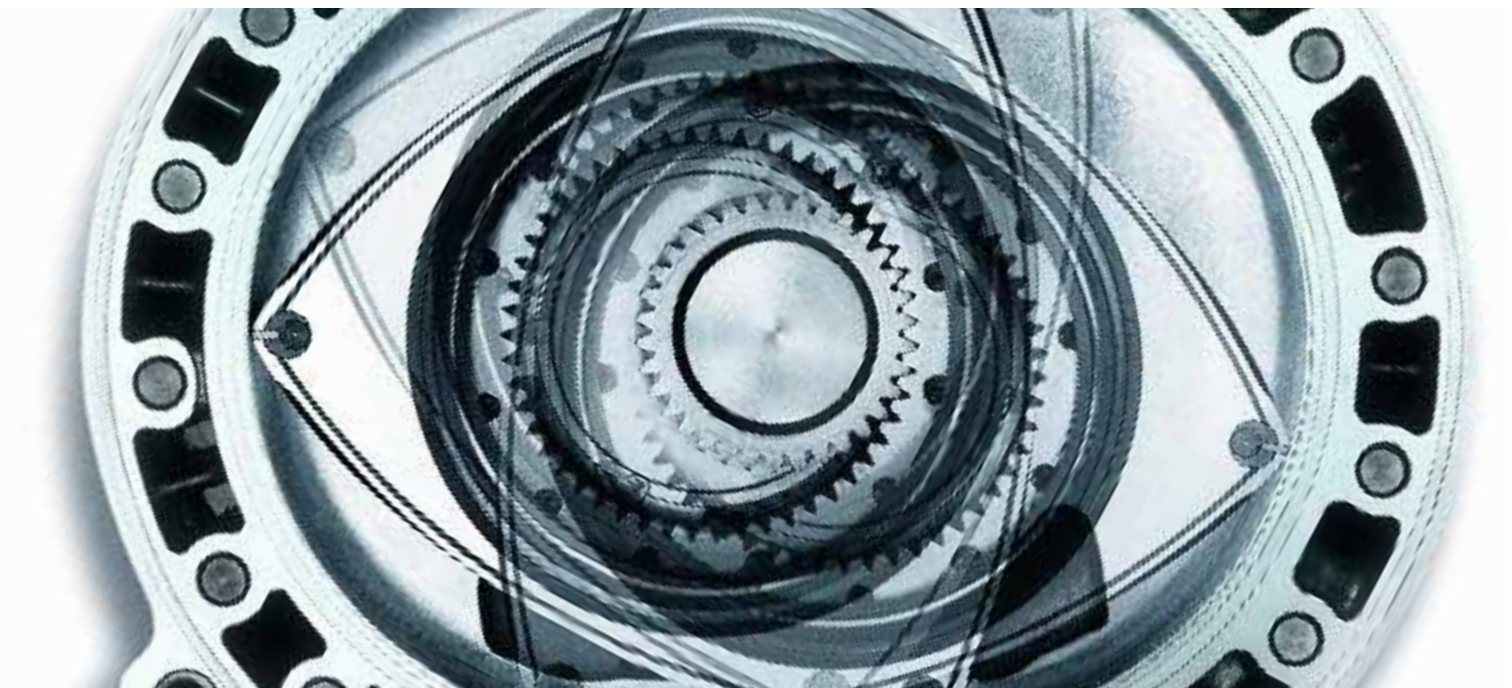





Papenburg automotive proving grounds, Germany, October 2004. Mazda engineers, drivers and technicians celebrated a new 24-hour endurance record. With average speeds of 132.269 and 134.181mph, two Mazda RX-8s drove more than 5,000km on the 12.3km oval track during a 24-hour period to set no less than 40 FIA International Endurance Records. The results clearly demonstrate that Mazda RX-8's revolutionary RENESIS rotary engine not only provides exhilarating performance, but also is durable and reliable even under the most extreme driving conditions.

In 1991, Mazda set the record at the Le Mans 24-hour endurance race. In 2004, they obliterated it with the two Mazda RX-8s.

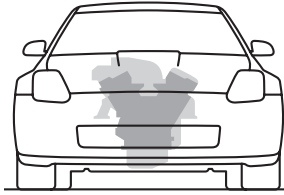

V6 engine.

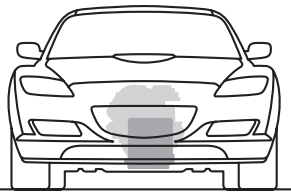

RENESIS rotary engine.

**Low centre of gravity.**

Lighter and smaller than piston engines of comparable power, the rear-wheel drive Mazda RX-8's rotary powerplant sits lower and further back in the frame, with the fuel tank ahead of the rear axle. Together with the long wheelbase, the result is an impressive power-to-weight ratio, a low centre of gravity and near-perfect 50:50 weight distribution for outstanding agility and stability.

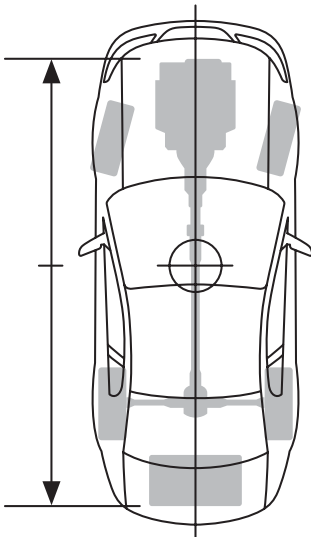

V6 engine.  
High polar moment.

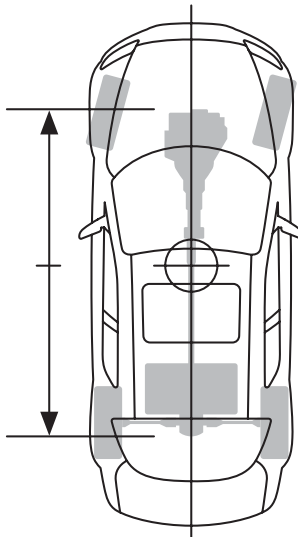

RENESIS rotary engine.  
Low polar moment.

**Balanced weight distribution.**

Uneven weight distribution can significantly impact on a vehicle's stability and handling. So the Mazda RX-8 is engineered to maintain a near-perfect 50:50 weight distribution, regardless of passenger load. The end result is a remarkably agile, well-balanced design.

**The centre point is the focus.**

Exemplary handling is achieved by positioning much of the Mazda RX-8's mass, including its powertrain and fuel tank, near the car's centre point – its yaw axis. 'Yaw' is movement to the left or right around the vertical axis. As the illustration shows, this gives the Mazda RX-8 a 'low-polar-moment-of-yaw' inertia, making it highly responsive to a change in direction. Cars with widely distributed masses have a 'high-polar-moment-of-yaw' inertia and tend to be less responsive and harder to control.



With an award-winning free-revving rotary engine at its heart, the Mazda RX-8 makes for a truly exhilarating drive. Breathtaking driving dynamics provide the perfect balance of power and stability. From the driver's seat, it means total confidence that the Mazda RX-8 will respond as precisely as you expect, delivering its power in a smooth and progressive flow. The result? 100% pure sports car.



The Mazda RX-8's chassis is exceptionally well balanced. Double-wishbone front suspension and multi-link rear suspension are precision-tuned to provide fluid handling and confident stability around sweeping bends or the tightest of corners. Razor-sharp electric power steering inspires massive confidence, with just 2.9 turns lock-to-lock. For added reassurance, Dynamic Stability Control (DSC) will help to keep you safely on track, working in conjunction with the limited-slip differential to maintain traction during rapid acceleration.













# a passion for design



The Mazda RX-8 boldly rejects convention. Like a breath of fresh air, it has brought original thinking into the world of sports coupés. Blending revolutionary 4-door versatility with sleek, aerodynamic styling, this is a beautifully thought-out sports car, designed completely without compromise.

Crouched close to the asphalt, every sensuous curve hints at the power beneath. Flared wheel arches frame the long, elegant bonnet and stretch over the purposeful 18" 5-spoke alloy wheels, placed at the extreme corners of the car for supreme stability and balance. Air outlets behind the front wheels reinforce the Mazda RX-8's predatory look, while the rotor's dynamic shape is reflected in the bonnet power bulge and echoed by the rear fog light, flanked by the engine's twin exhaust pipes.

From every angle, the Mazda RX-8 signals its sports car credentials.





The pillar-less, 'freestyle' door system provides exceptionally easy access to the roomy interior. The front and rear doors open from the centre for you and three adult passengers to experience the fun.

The Mazda RX-8's advanced body architecture incorporates MAIDAS, Mazda's Advanced Impact Distribution and Absorption System, to enhance driver and passenger safety.

Ingenious 'freestyle' doors blend 2-door styling with 4-door flexibility, without compromising on safety standards. Extensive reinforcement of the rear doors creates an integrated B-pillar when the doors are fully closed, significantly enhancing body side strength. To continue the coupé styling, the rear door handles are hidden, while the front doors close only after securing the rear doors.

Ventilated 4-wheel disc brakes, enhanced by an Anti-lock Braking System (ABS) and Electronic Brake-force Distribution (EBD), provide exceptional feel and make it easy to judge how much power to apply to the pedal to safely scrub off a little speed before entering a corner, or bring the car to a standstill quickly and safely. In addition, Dynamic Stability Control (DSC) and a Traction Control System (TCS) provide intelligent, reassuring handling by subtly assisting at the limits of grip without diminishing your driving pleasure.



1 3  
2 4



- 1 **Cabin reinforcement.**  
A ring-shaped structural reinforcement around the door opening in each of the body's side panels improves cabin rigidity. These structural reinforcements result in maximum strength and stiffness. A collapsible brake pedal further helps prevent ankle injury in a front impact.
- 2 **Airbag system.**  
Driver and front passenger airbags, as well as side and curtain airbags, help to ensure all-round passenger safety in case of side collisions and also prevent passengers from being thrown from the vehicle.
- 3 **Strengthening V-brace.**  
A V-shaped diagonal brace is attached to the top mounting of each rear suspension damper, giving rigid damper support and promoting torsional rigidity at the rear of the body.
- 4 **Door structure.**  
A reinforced structure in the front edges of the rear doors forms a virtual centre-pillar that locks into the roof and floor, increasing body rigidity and side-impact protection.





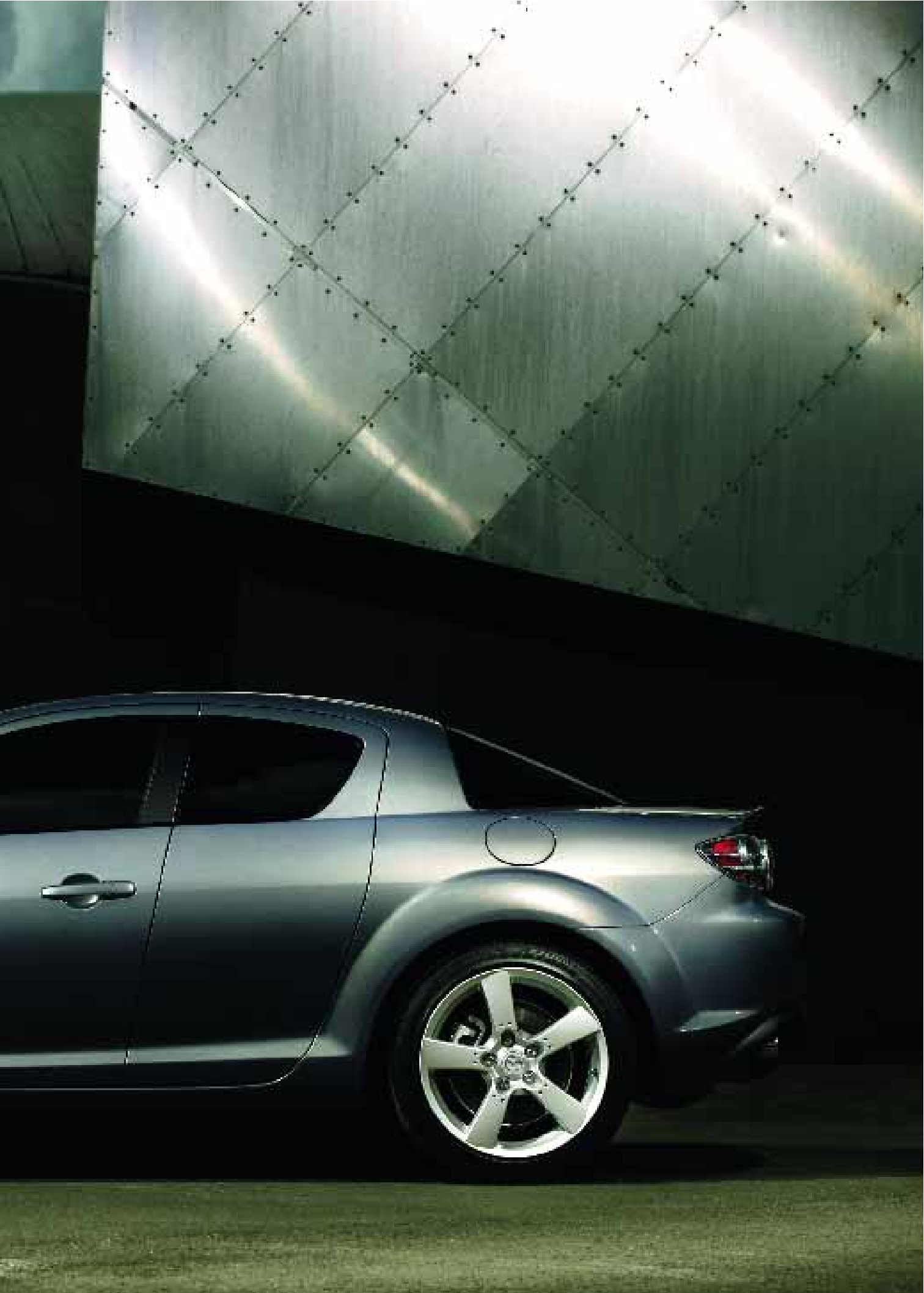



# pushing the boundaries

For a dedicated sports car, the Mazda RX-8 is unexpectedly roomy, with plenty of space for the driver and three adult passengers. No matter where you sit, you are sure to enjoy the ride. The low-slung front sports seats have deep, supportive side bolsters and offer an adjustable driving position. In the rear, sculpted front seatbacks free up even more space. All essential controls are well within reach for intuitive operation.





The interior styling is faultless down to the smallest detail. Beautiful leather or cloth trim? The choice is yours. Choose leather and the driver's seat will be power-adjustable, with heated seats for you and your front passenger. Throughout the cabin, cool technical aluminium detailing marks this out as a true sports car, while the rotary design cues continue with a distinctive rotor-shaped gear knob and front seatback apertures.

What you may not expect, however, is the large, easily-accessible boot. With more than 290 litres of luggage space, plus the convenience of a ski-hatch between the rear seats, the Mazda RX-8 will easily accommodate two golf bags or weekend cases.



Settle into the driver's seat, grip the tilt-adjustable leather-wrapped steering wheel and you are in complete control. Instrumentation is precisely where it should be, clearly visible within three deeply-cowled dials, with a tachometer boldly taking centre stage.

The driver-focused instrument panel is the ideal demonstration of the Mazda RX-8's sports car credentials. Back-lit dials provide a sporty reminder of the type of car you are in control of, whilst piano black trim and subtle detailing extend that feel to one of luxury and convenience. The Mazda RX-8 isn't just a sports car designed to look good. This car achieves greatness too, with every control, every gauge and every dial being intuitively positioned, designed to help augment that already exhilarating driving experience.

# The Bose® sound system for the Mazda RX-8



Set into the dramatic piano-black centre console, a custom-tuned premium Bose® audio system provides entertainment for your listening pleasure. With nine surround sound speakers and a 6-CD in-dash autochanger, it will envelop you in pure, crystal-clear sound.

## Nine high-performance speakers:

- 1 8cm mid / high-range speaker in the centre of the instrument panel.
- 2 5cm mid / high-range speaker in each front door.
- 3 23cm Nd® woofer powered by a dedicated two-state switching modulation amplifier in each front door.
- 4 Two 5cm mid / high-range speakers mounted with two 15x23cm woofers on the rear shelf.

## System electronics:

- 5 Digital amplifier below rear parcel shelf with five channels of customised equalisation and AudioPilot™ noise compensation technology.
- 6 AudioPilot™ system microphone next to the steering column.

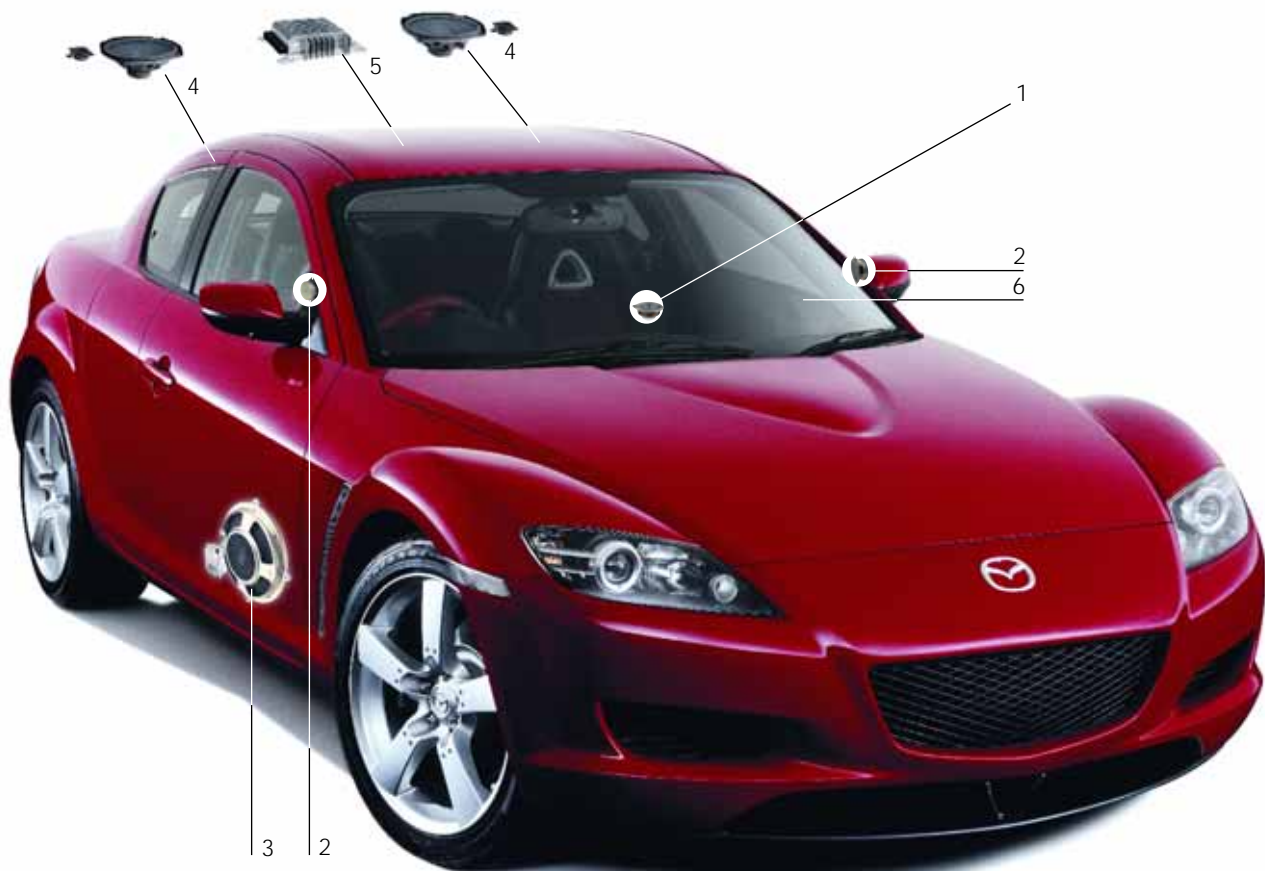

Image above shows Mazda RX-8 (192ps) with optional mica paint and red / black leather trim.









# freedom of choice

With two powerful interpretations of the award-winning Mazda RX-8 to choose from, we know it can be tough to decide. But whether you favour the 192ps RENESIS engine or the 231ps version, you can be assured of a genuinely unique sports car, powered by race-proven technology, for those who love the road.





Not only does the Mazda RX-8 deliver the ultimate in driving enjoyment through its remarkable power, roadholding and handling, it also indulges its passengers in a refined and luxurious environment. From the aluminium interior detailing to the drilled alloy pedals<sup>1)</sup> and the optional DVD satellite navigation system<sup>2)</sup>, each discovered detail serves to heighten your driving pleasure.

With the Mazda RX-8, a leather interior is not only an option, but a selection of options. Choose from an all-black leather interior, a sporty combination of black and red leather or stylish stone leather trim<sup>3)</sup>. In choosing from these trim options, you can be sure your sculpted sports seats reach the pinnacle of luxury.

<sup>1)</sup>Standard on 231ps model.

<sup>2)</sup>Only available with optional leather trim.

<sup>3)</sup>See Page 35 for colour and trim availability.



The stunning Mazda RX-8 already stands out from the crowd. But because only you know what you really desire, we have left plenty of scope for you to express your individuality by choosing from a comprehensive range of high-quality accessories.

- 1 Brushed aluminium fuel cap.
- 2 B-pillar trim.
- 3 Exhaust trim surround.
- 4 Scuff plate.
- 5 Leather gear lever knob with illumination.
- 6 Leather handbrake lever.





Images show accessories available at extra cost.

# Mechanical Features

## Engines:

- RENESIS rotary engine available with either 192ps or 231ps.
- Two 654cc rotor units.
- 3-way catalytic converter with feedback loop.
- Multi side port with side intake, side exhaust configuration.
- Ignition system: Distributor-less.
- Recommended fuel: Unleaded fuel (min 95 RON).
- Alternator: 12-100A.
- Starter: 12V, 1.4kW.
- Battery: 12V 70AH DIN 57029.
- Emissions Standard Euro IV.

## Transmissions:

- Clutch type: Single dry plate.
- 5-speed (192ps) or 6-speed manual (231ps).
- Super Limited-Slip Differential (LSD) for maximum traction.
- Rear-wheel drive.

## Body:

- Light, highly rigid dedicated sports car platform for superior sports handling and driving dynamics.
- High-tensile steel reinforcing members in front and rear doors for side-impact protection.
- 4-door coupé 'Freestyle' door system for increased access to interior cabin.
- Use of aluminium construction for reduced bodyweight.

## Chassis and Suspension:

- Double-wishbone front suspension.
- Multi-link (five-link) rear suspension.
- Shock absorber type: Telescopic, oil and gas filled.
- Sports suspension.

## Brake System:

- Anti-lock Braking System (ABS) with Electronic Brake-force Distribution (EBD).
- Front and rear: Ventilated discs.
- Mechanical parking brake acting on rear wheels.





# Technical Data

<b>Engine</b>		Mazda RX-8 (192ps)	Mazda RX-8 (231ps)
Displacement (cc)		2 x 654	2 x 654
Maximum output [ps (kW) / rpm]		192 (141) / 7000	231 (170) / 8200
Maximum torque (Nm / rpm)		220 / 5000	211 / 5500
Compression ratio		10:1	10:1
Redline (rpm)		7500	9000
<b>Transmission</b>			
Type		5-speed manual	6-speed manual
Gear ratios:	1st	3.483	3.760
	2nd	2.015	2.269
	3rd	1.484	1.645
	4th	1.000	1.187
	5th	0.762	1.000
	6th	–	0.843
	Reverse	3.288	3.564
Final gear ratio		4.444	4.444
<b>Steering</b>			
Steering gear		Power-assisted rack and pinion	
Minimum turning circle (kerb-to-kerb) (m)		10.6	10.6
<b>Performance and Economy</b>			
Acceleration [0-62mph (0-100km/h) in sec]		7.2	6.4
Top speed [mph (km/h)]		139 (222)	146 (234)
Fuel consumption <sup>1)</sup> [mpg (l/100km)]	Urban	19.0 (14.9)	18.1 (15.6)
	Extra Urban	34.9 (8.1)	32.5 (8.7)
	Combined	26.7 (10.6)	25.2 (11.2)
CO <sub>2</sub> emissions <sup>1)</sup> (g/km)		267	284
Stopping distance [(m) 62-0mph]		36	36
Fuel tank capacity (l)		61	61
Engine oil capacity (l)		6.1	6.9
Coolant capacity (l)		8.7	8.7

<sup>1)</sup> Fuel consumption and CO<sub>2</sub> emission values according to 80/1268 EWG (1999/100/EC).





# Technical Data

## Dimensions and Weights

	Mazda RX-8 (192ps)	Mazda RX-8 (231ps)
Overall length with licence plate holder / width / height unladen (mm)	4430 / 1770 / 1340	4430 / 1770 / 1340
Unladen ground clearance (mm) between the axles	140	140
Front track / Rear track (mm)	1500 / 1505	1500 / 1505
Wheelbase (mm)	2700	2700
Front headroom / leg room / shoulder room (mm) (without sunroof)	970 / 1084 / 1393	970 / 1084 / 1393
Front headroom / leg room / shoulder room (mm) (with sunroof)	932 / 1084 / 1393	932 / 1084 / 1393
Rear headroom / leg room / shoulder room (mm) (without sunroof)	935 / 817 / 1395	935 / 817 / 1395
Rear headroom / leg room / shoulder room (mm) (with sunroof)	927 / 817 / 1395	927 / 817 / 1395
Cargo area volume, according to VDA (l) (accommodates full set of golf clubs)	290	290
Ventilated front disc diameter (mm)	323	323
Ventilated rear disc diameter (mm)	302	302
Kerb weight without driver (kg)	1373 (max)	1379 (max)
Permitted gross vehicle weight (kg)	1820	1815
Towing limit (kg)	Unbraked Braked (12% gradient)	695 1200
Maximum roof load (kg)	75	75
Coefficient of drag (CD)	0.30	0.30

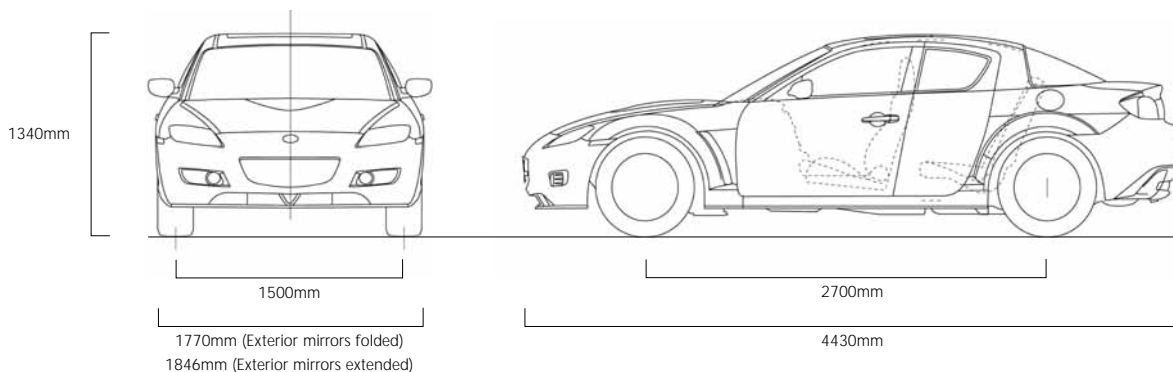

## Safety and Security

	Mazda RX-8 (192ps)	Mazda RX-8 (231ps)
Mazda Advanced Impact Distribution and Absorption System engineered 'triple H' body structure to help protect occupants from impact forces	●	●
Supplementary Restraint System (SRS) – Central control unit and crush sensors, front seatbelt pre-tensioners, load-limiters and airbag system	●	●
4-wheel disc brakes (front and rear ventilated)	●	●
Anti-lock Braking System (ABS) with Electronic Brake-force Distribution (EBD)	●	●
Dynamic Stability Control (DSC)	●	●
Traction Control System (TCS)	●	●
Super Limited-Slip Differential (LSD)	●	●
Dual front airbags	●	●
Side airbags (front)	●	●
Curtain airbags (front and rear)	●	●
Passenger airbag deactivation system	●	●
Intrusion-minimising brake pedal	●	●
Front seatbelt pre-tensioners and load limiters	●	●
ISOFIX child seat anchorages on rear seats	●	●
Thatcham Category 1 alarm (with intruder sensor) and immobiliser	●	●

## Exterior

Tyres and wheels: 225/45 R18 with 18x8JJ aluminium wheels	●	●
Emergency tyre repair kit (in lieu of spare wheel)	●	●
Bumper, front and rear: Body colour	●	●
Rear heated glass window	●	●
Wiper, 2-speed with intermittent wipe and wash	●	●
Headlights: Halogen	●	–
Xenon	–	●
Headlight levelling: Manual	●	–
Automatic	–	●
Headlight washer jets	–	●
Front fog lights	●	●
Rear brake light, high-mounted, rear fog light	●	●
Door mirrors: Power-operated and heated, driver's wide angle with 'puddle' lights, body colour housings	●	●
'Freestyle' door system	●	●
Door outer handle: Body colour	●	●
Rear lip spoiler	●	●
Sunroof, power tilt and slide	○	○
Body colour fuel filler cap	●	●
Metallic / Mica paint	○	○

- = Standard.
- = Option, at extra cost.
- = Not available.



# Equipment

## Comfort and Convenience

	Mazda RX-8 (192ps)	Mazda RX-8 (231ps)
Power steering (engine speed sensing)	●	●
Power windows: One-touch auto down on driver's side	●	●
Rear quarter windows: Flip open	●	●
Air conditioning: Climate control	●	●
Footrest (driver's side)	●	–
Footrest, aluminium (driver's side)	–	●
Aluminium pedal set	–	●
Scuff plates: Aluminium	●	●
Sunvisors, with illuminated vanity mirrors	●	●
Boot lid, remote opening (electric)	●	●
Fuel cap, remote opening (cable)	●	●
Remote central door locking with deadlocking	●	●

## Interior Features

Seats and integral head restraint:	Front, bucket seats with integral head restraints	●	●
	Driver's, dial reclining and height adjustment	●	●
	Cloth, black	●	●
	Leather <sup>1)</sup> trim includes driver's power seat and front heated seats	○	○
	Rear seats, 'boot through' box in centre	●	●
Steering wheel:	Leather-wrapped with tilt adjustment	●	●
Gearshift knob:	Leather-wrapped with aluminium insert	●	●
Door inner handles:	Front, chromed. Rear, black	●	●
Panel light control with dimmer		●	●
Headlight On reminder (sound warning)		●	●
Audio and Navigation System:	Premium BOSE® audio system with 6-CD autochanger, AM/FM radio and nine speakers	●	●
	DVD navigation system (available with leather option only)	○	○
Antenna:	Rear window	●	●
Meter set:	Tachometer, digital speedometer, fuel gauge, engine oil-pressure gauge, water temperature gauge, metallic meter rings, digital exterior temperature indicator	●	●
Warning lights:	Brake system, charging system, SRS, ABS, passenger airbag deactivation system, immobiliser, oil low, seatbelt reminder, fuel low	●	●
Digital clock		●	●
Centre console:	Front and rear (rear with lid)	●	●
Interior light, dome with integral spotlight		●	●
Courtesy lights, front doors		●	●
Luggage compartment light		●	●
Inner mirror (day / night)		●	●
Storage space:	Glovebox, lockable with illumination	●	●
	Seat-back pocket (passenger's side)	●	●
	Rear console box with lid	●	●
	Door pockets (front)	●	●
Cigar lighter and illuminated front ashtray		●	●
Grab handle, front passenger's		●	●
Cup holders, two front and two rear		●	●
Heater controls, power-operated		●	●
Heater ducts, rear		●	●
Pollen filter		●	●

● = Standard.

○ = Option, at extra cost.

– = Not available.

<sup>1)</sup> Leather refers to centre seat facing and side supports.



# a sports car redefined

It's revolutionary. It's powerful. It's fun to drive. And it's the only rotary-engined production car in the world.

The stunning Mazda RX-8 will stir your soul and ignite your passion for driving.

Inspired by the innovative RENESIS rotary engine, the Mazda RX-8 is both a design and engineering marvel.

A unique blend of visionary style, turbine-smooth power and razor-sharp handling, with the ability to carry four people in comfort. The Mazda RX-8 will challenge your senses and redefine your expectations of a sports car.

Now that's Zoom-Zoom.

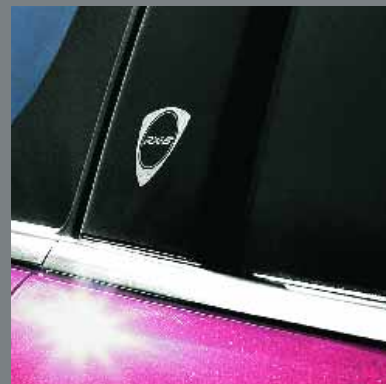
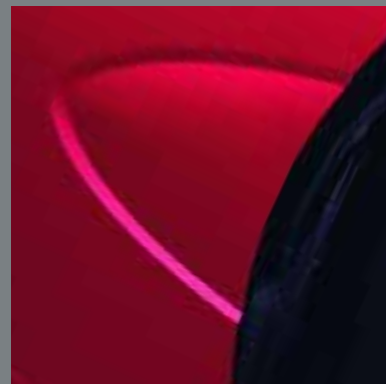

## Colour and Seat Trims

Trim	Black cloth	Black leather*	Red / Black leather*	Stone leather*
Environment colour	Black	Black	Black	Black
<b>Solid Body Colours</b>				
Brilliant Black	■	■	■	■
<b>Metallic / Mica Body Colours*</b>				
Galaxy Grey Mica	■	■	-	■
Stormy Blue Mica	■	■	-	■
Sunlight Silver Metallic	■	■	-	■
Velocity Red Mica	■	■	■	■
Winning Blue Metallic	■	■	-	■

\*Option, at extra cost.  
■ = Available.



Black cloth



Black leather\*



Red / Black leather\*

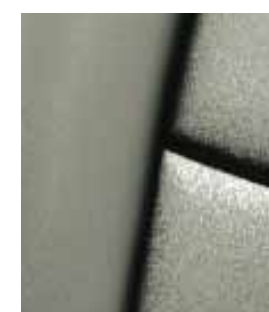

Stone leather\*



Brilliant Black



Galaxy Grey Mica



Stormy Blue Mica



Sunlight Silver Metallic



Velocity Red Mica



Winning Blue Metallic

## Mazda RX-8 Configurator

### Bodystyle

Mazda RX-8

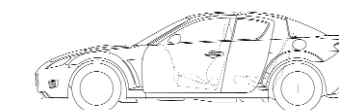

### Engine and Transmission

RENESIS 192ps with 5-speed manual transmission

RENESIS 231ps with 6-speed manual transmission

**Options** (e.g. metallic / mica paint, power sunroof, leather seats, DVD navigation system.) Please refer to pages 33-34 for full option listings.

### Exterior colour

e.g. Galaxy Grey Mica

### Seat trim

e.g. Red / Black leather

**Service Options** (e.g. customised finance and insurance packages, 'Service Plus' inspection package, extended new car warranty). Please refer to back cover.