

NISSAN PRIMASTAR



[Introduction](#) | [Exterior](#) | [Comfort and technology](#) | [Performance](#) | [Safety](#) | [Load space](#) | [Combi Version](#) | [Equipment and Options](#)

[Print](#) | [Close](#)

[Finishing](#) | [Versions](#) | [Dimensions](#) | [Colours](#) | [Accessories](#) | [Technical Specification](#) | [Price List](#)



SHIFT_ the way you move

Everything we touch, we SHIFT_. And everything we SHIFT_ we try to make uniquely better. We design our LCVs to succeed in the tough working world, by helping you work smarter, not harder. The Nissan range of LCVs offers the ideal solution for every size and type of business, from sole traders to large fleets. From the compact yet roomy NV200, the medium-sized PRIMASTAR and larger INTERSTAR vans, to the renowned CABSTAR light truck, every vehicle is focused on helping you achieve more, in comfort and safety, with optimum reliability and minimum costs. You can depend on Nissan LCVs to improve your business performance.

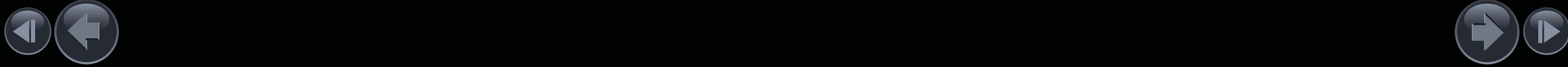



The PRIMASTAR range offers such an extensive choice that it's easy to create a vehicle that exactly suits your needs. The Van is available in two lengths and two heights, to match your daily cargo needs. The Good to Go conversion programme gives you further options with a six seat Crew van and Freezer or Chiller van.



BUILT AROUND YOU

The Minibus, also available in two lengths, takes loads plus workmates or passengers with ease. With a choice of engines, up to three grades and numerous options, you can see how PRIMASTAR is the ultimate made-to-measure business vehicle.



8.4 M³
MAXIMUM FLEXIBLE LOAD SPACE

1,285 KG
MAXIMUM PAYLOAD

UP TO 150 HP

3-YEAR
WARRANTY



[Introduction](#) | [Exterior](#) | [Comfort and technology](#) | [Performance](#) | [Safety](#) | [Load space](#) | [Combi Version](#) | [Equipment and Options](#)

[Print](#) | [Close](#)

[Page 1](#) | [Page 2](#)

[Finishing](#) | [Versions](#) | [Dimensions](#) | [Colours](#) | [Accessories](#) | [Technical Specification](#) | [Price List](#)





ENHANCE YOUR STATUS

Driving a PRIMASTAR immediately conveys a powerful, positive impression. Its thoroughly modern design and attractive yet practical features, conveys a message of strength and efficiency to the outside world. With even greater attention to detail and quality, choosing Primastar proves your shrewd judgement.

The new front design incorporates combined headlamps and indicators that ensure you can see and be seen more easily – a benefit that also applies to the new rear lights. A larger rear bumper provides increased protection against every day knocks. With different paint treatments for the bumpers and body mouldings, the Van and Minibus have clearly individual identities that set them – and you – apart on the road and in the car park.



IMPRESSIVE DESIGN

[Introduction](#) | [Exterior](#) | [Comfort and technology](#) | [Performance](#) | [Safety](#) | [Load space](#) | [Combi Version](#) | [Equipment and Options](#)

[Print](#) | [Close](#)

[Finishing](#) | [Versions](#) | [Dimensions](#) | [Colours](#) | [Accessories](#) | [Technical Specification](#) | [Price List](#)





USER-FRIENDLY TECHNOLOGY

THE COMFORT ZONE

Inside, PRIMASTAR feels more like a car than a van. The new high quality trim is smart and inviting, again with three distinct finishes for the Van, and Minibus. Even more impressive is the level of equipment available to make driving easy and more comfortable.

The fresh new dashboard design features extra, practical storage spaces and a new range of audio systems featuring Bluetooth® for hands-free phone use on SE and SE+ grade, remote controls and convenient auxiliary input for your iPod and MP3 players.

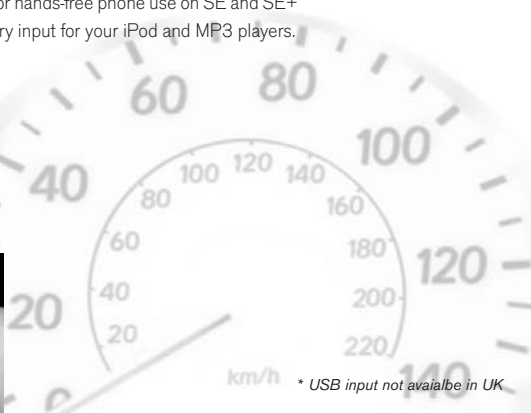

Driver-friendly technology available for PRIMASTAR includes automatic wipers with speed adaptive function, automatic lighting with friendly lighting function, rear parking sensors, air conditioning, cruise control. You can also have a 3-button key, which lets you lock and unlock the front and cargo doors separately.

Climate control replaced by Manual air conditioning in UK





HIGHER EFFICIENCY

PRIMASTAR's wide range of engines ensure easy load hauling ability, quiet cruising and responsive acceleration. All versions are equipped with a 6 speed manual gearbox and as an option you can specify the 6 speed semi-automatic transmission which helps to reduce wear on your transmission as well as giving you an easier drive in congested stop-start conditions.

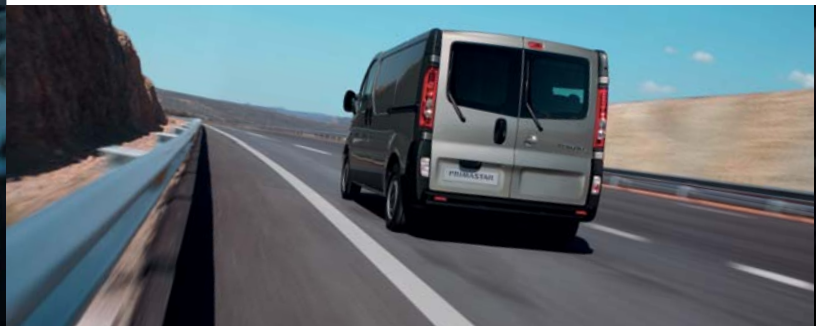

With long maintenance intervals for lower running costs, and improved environmental responsibility, the new engine range makes driving PRIMASTAR feel even better.



UP TO
150HP





A TRUSTED WORKER



With its renowned Nissan reliability, it might seem that all you have to do with PRIMASTAR is keep it clean. You can certainly drive a long way between service appointments, with up to 18,000 between services.

The latest PRIMASTAR has a 3-year, 100,000 mile warranty, 6-year paint warranty and 12-year anti-corrosion warranty. PRIMASTAR is designed for easy repair – keeping your maintenance and insurance costs low. So it's just as well that this dependable, desirable vehicle is protected by an alarm system and immobiliser.



LOW COST OF OWNERSHIP LONG SERVICE INTERVALS

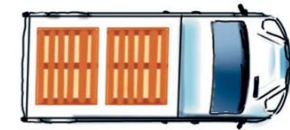

VAN L1H1
The shorter Primastar can
load 2 Euro-pallets

5 M³ MAXIMUM LOAD SPACE



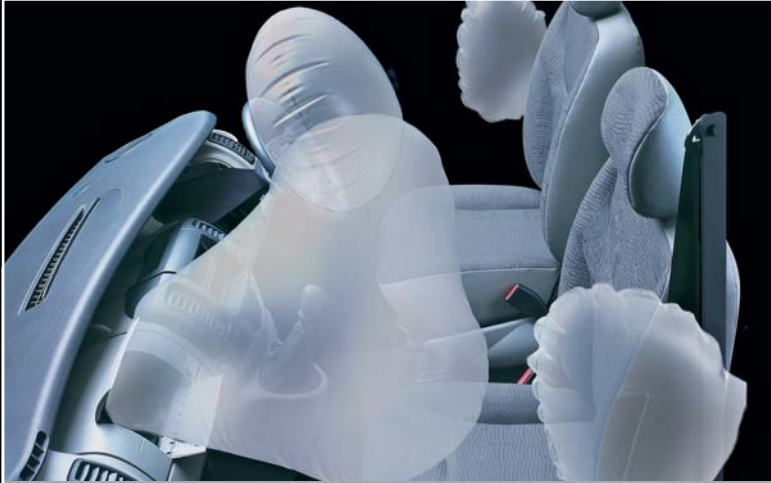

AGILE AND TOUGH

Accidents and incidents happen suddenly and without warning. Fortunately, Primastar is designed to respond rapidly and decisively to your control. With all-wheel disc brakes, EBD (Electronic Brake force Distribution) and standard ABS and EBA (Emergency Brake Assistance), PRIMASTAR has one of the shortest stopping distances in its class. The optional ESP (Electronic Stability Program) further supplements PRIMASTAR's agile handling during routine driving and in the event of emergencies.



ABS & EBA EBD ESP

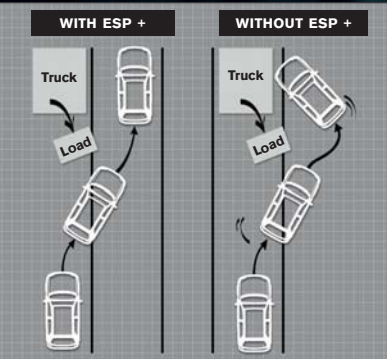

The tough reinforced cabin structure provides maximum protection in case of accident, whereas seatbelts with pretensioners and load limiters combined with airbags for driver and optionally for passenger, complete the safety equipment of PRIMASTAR. In addition, the passenger airbag can be deactivated if you need to carry a child seat. The rain sensor provides extra safety where specified. Set the wiper switch to the rain sensor function and they'll be activated automatically whenever they're needed, while the speed adaptive feature will vary their frequency according to PRIMASTAR's road speed. This improves visibility and leaves you free to concentrate. And as an extra precaution, the doors lock automatically when you reach 5mph.



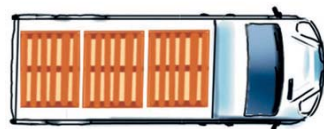

*VAN L2H2
The bigger PRIMASTAR
was designed to load
up to 3 Euro-pallets*

Load space is understandably one of the vital considerations when you're choosing a van. PRIMASTAR takes an impressive amount of cargo: up to 1,200kg payload for the SWB van in either height, with 5m³ of usable volume, up to 7.1m³ for the taller version.

8.4 M³
MAXIMUM LOAD SPACE



EASY TO LOAD, HARD TO FILL



PRIMASTAR helps you make the most of all that space. With 1m wide sliding side doors available on both sides and a low floor, it's easy to load the 2.4m long cargo deck (2.8m long in the LWB version). To make sure your loads are properly secure, there plenty of anchorage points on the floor and all points are reinforced for extra strength.

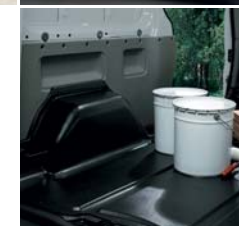

TAKE ON MORE

Long loads can be awkward to carry – unless, of course, you have a long wheelbase PRIMASTAR. 2.8m internal length and a 1,200kg payload means you can accommodate carpets, timber, pipes – whatever the day's challenging load might be. That's 5.9m³ of usable space or a vast 8.4m³ for the taller van.



With the long version PRIMASTAR, in either height, you can specify rear doors that open 250°, folding flat right against the sides of the van to give you totally unimpeded loading access.



2,800MM LONG
LOAD FLOOR



MINIBUS: YOU WIN AGAIN



With the PRIMASTAR Minibus you win both ways, with space to carry your workmates and their tools or your sports team and their kit. Entry and exit is easy with sliding doors on both sides. The Minibus is well appointed and comfortable; all seats have headrests and 3-point seatbelts and with optional air conditioning, you can maintain your preferred temperature throughout your journey. Yet it's still practical and durable enough to withstand the knocks that inevitably come from carrying equipment everyday.

PRIMASTAR is also available as a 6 seat Crew van with a secure load space separated from the cabin by a full bulkhead.

The Minibus is available in two lengths. The standard version (L1) seats nine people with nearly 0.45m for loads, or if you fold down the rear seat, six people with over 1.5m of load space length. Choose the long wheelbase version (L2), and those cargo lengths increase to nearly 1.2m and over 1.9m respectively, while the load volume goes up from 1.2m³ to 4m³. And you can completely remove the third row and fold the second row for maximum load carrying when you need it. The load space incorporates four anchorage points, ready for attaching an optional cargo net.

9
SEATS

4M³
FLEXIBLE LOAD SPACE



REDUCE YOUR WORK LOAD

With an exceptional choice of driver-friendly equipment available, PRIMASTAR leaves you free to concentrate on the road and on your business.



SPEED LIMITER AND CRUISE CONTROL

This feature on SE+ models helps you comply with the law, avoid speeding tickets and make light work of long journeys, by maintaining any speed you choose above 20 mph. Press the + or - buttons on the steering wheel to set your chosen speed (displayed on the dashboard). PRIMASTAR stays at this speed and won't exceed it, unless you push hard on the accelerator. Using the accelerator or the brake immediately overrides the system, making sure you always retain full control.

THREE-BUTTON KEY

This remote central locking key lets you lock and unlock doors selectively. You can choose to lock or unlock the front doors only, or the loading area separately, including side and rear doors. For optimum convenience, you can also lock or unlock all doors at a time.

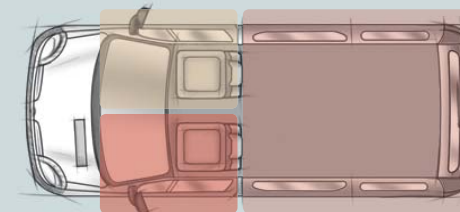

RAIN SENSING AND SPEED ADAPTIVE WIPERS

The wipers are automatically activated by rain on the windscreen, and adapt to the amount of rain and to PRIMASTAR's speed. Below 3mph, the wipers revert to the next lowest setting, e.g. from continuous to intermittent. This is especially helpful in stop-start city driving, leaving you free to keep your hands on the wheel.

AUTOMATIC LIGHTING

As long as the engine is running (and you've switched on the function), dipped headlights will switch on automatically when the sensor detects that the ambient light requires them. Another innovation that reduces your workload, particularly when conditions are deteriorating.



FRIENDLY LIGHTING

This feature is really helpful if you're making deliveries at night. When the engine's turned off, pull the headlamp stalk briefly to the flash setting, and the headlights will stay on for 30 seconds. You can pull the stalk up to four times, giving you as long as 2 minutes – usually plenty of time to find your way.



REDUCE YOUR WORK LOAD



REAR PARKING SENSOR

On all PRIMASTAR SE and SE+ models, this feature means you can be confident that you won't damage your PRIMASTAR or any person or object behind it. Operating automatically when you engage reverse, the system emits a beep which becomes more frequent the closer you are to the object behind. When the beep is continuous, it's time to stop! The sensors are specially designed for PRIMASTAR's low loading sill and can be turned off if you're towing a trailer.

AIR CONDITIONING

The manual air conditioning system is an option on SE models and is standard on SE+ versions, helping you to enjoy a comfortable drive.



ONE TOUCH POWER WINDOWS

The electric windows will raise or lower with only one firm touch of the button – useful at barriers as your hand can go straight back to the steering wheel.



AUDIO RANGE

The audio range includes CD radio with an aux input jack for you MP3 player as standard equipment on all models. To make you life easier the remote audio controls allow you to operate the audio system without taking your hands off the wheel.



BLUETOOTH®

Bluetooth® is a practical, convenient way to link your mobile phone wirelessly to PRIMASTAR's audio system, so you can stay in touch at all times. You can take and make calls hands free*, and browse your phonebook contacts via the audio system's display. Bluetooth® can also play music from your compatible MP3 player or MP3 phone via streaming audio.

*For greater safety, we recommend you stop to make phone calls.

REINFORCED ANTI-THEFT SYSTEM

To safeguard your goods, tools and personal items, PRIMASTAR offers a well-designed security system with protected keyholes and reinforced door locks. The security encoded key makes it virtually impossible to unlock the vehicle using any other key, and the optional built-in alarm will sound if any attempt is made to force a way in.



AUTOMATIC DOOR LOCK WHILE DRIVING

To keep you and your loads secure, all the doors lock automatically when PRIMASTAR goes above 8km/hr.

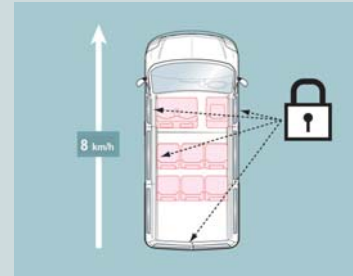

AUDIO AND PHONE REMOTE CONTROL

For extra convenience and safety you can control the main functions of the audio system, such as volume, source and track selection, using this steering column-mounted switch. If you have a Bluetooth®-enabled phone, you can use the same switch to start and stop calls. All without taking your hands from the steering wheel.

TACHOGRAPH

To help you comply with legislation, an advanced digital tachograph is available as an option separate smart card readers for two drivers and the ability to use a company smart card to transfer data between the tachograph and a PC. The comprehensive information display includes driver activity, time and distance, and the integrated printer can produce reports for instant checking.



THE PERFECT FIT

PRIMASTAR's many features and options have been designed with real business needs in mind. So if you have special requirements it's most likely that PRIMASTAR can satisfy them.



TUBULAR PARTITION

COAT HANGER

This useful coat hanger is ideally located on the partition wall.



PARTITION WALL, GLAZED

BULKHEADS

A tubular partition is standard on E grade vans and provides protection for the driver from sliding loads, while still allowing access from the front passenger seats to the load space. For your safety and the security of your goods SE and SE+ models have a full steel bulkhead for optimum load protection and increased comfort for everyday use by effectively reducing noise.

PARTITION WALL, PANEL

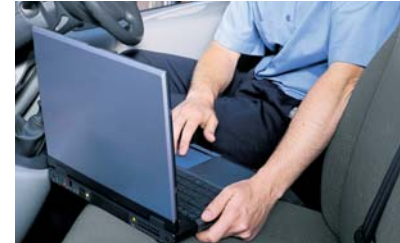

EXTRA ELECTRICAL CAPACITY

If you frequently use electrical accessories such as a portable navigation system, a phone kit or a DVD player for your children, it's worth having the peace of mind of PRIMASTAR's "heavy duty" system. It provides either 85Ah or 95Ah for high-demand situations.



SECOND BATTERY RACK

If you frequently need a power supply when the engine's not running (for example, if you want to run a refrigeration unit) a second battery rack is available to house an independent power supply. This option provides the rack only, allowing you to choose the battery based on your particular application.



ADDITIONAL ANCHORAGE POINTS

Two new anchorage points on the load space floor help keep your cargo safe and secure, complementing the anchorage points on the body sides. The hooks have been designed to withstand loads of up to 625kg.



12 V MULTI-PURPOSE SOCKET

A 12V socket is conveniently located on the central dashboard so you can recharge your mobile phone, your PDA or your laptop (using the special adapters required by your device). In the Minibus, passengers can benefit from a second 12V socket located on the side wall between the second and third row of seats.



TWO SLIDING DOORS

Sliding doors help you access your loads more easily. They are available for both sides of the PRIMASTAR Van and are offered for the standard and long wheelbase Minibus, greatly increasing your passengers' comfort and your loading options.



NEW HEATING SYSTEM

The new heating system now distributes warm air directly to your feet and can supply considerably more heat to the rear of the vehicle. This is particularly useful for keeping all the passengers comfortable and happy in your Primastar Minibus.





[Introduction](#) | [Exterior](#) | [Comfort and technology](#) | [Performance](#) | [Safety](#) | [Load space](#) | [Combi Version](#) | [Equipment and Options](#)

[Print](#) | [Close](#)

[Finishing](#) | [Versions](#) | [Dimensions](#) | [Colours](#) | [Accessories](#) | [Technical Specification](#) | [Price List](#)



BODY STYLES

VAN BODY STYLES

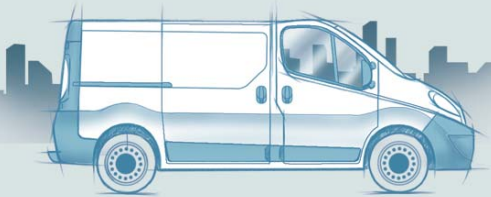

L1H1

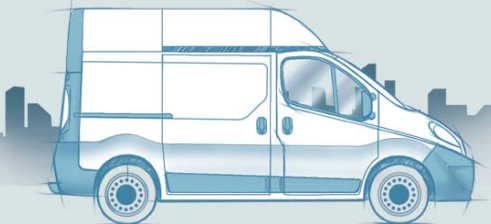

L1H2

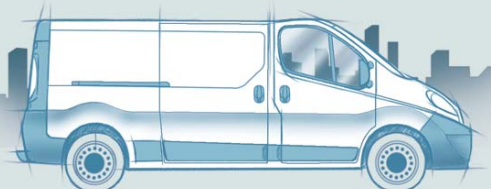

L2H1

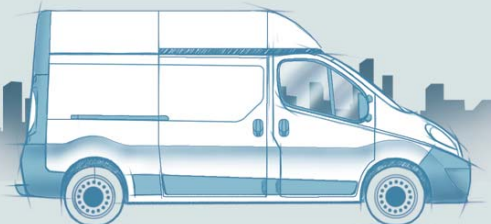

L2H2

Choose which PRIMASTAR your business needs: Van or Minibus. Then you can choose from two lengths, two heights (depending on the variant) and details such as glazed or panel side doors, hinged solid or glazed rear doors or glazed tailgate.

VAN SIDE WINDOWS

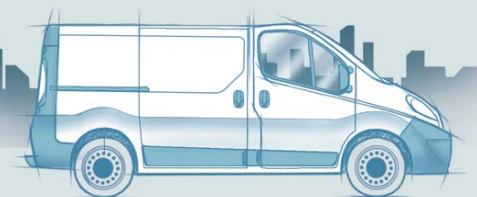

Full panel sides

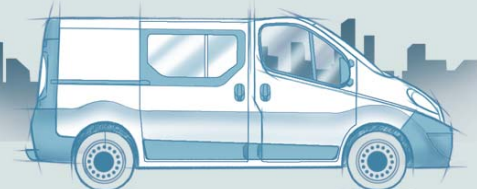

Half-glazed side, one side

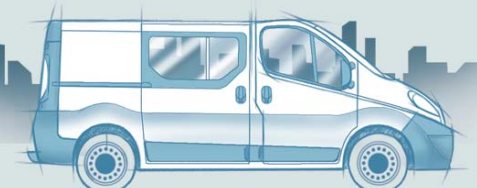

Half-glazed side, both sides

VAN AND MINIBUS SLIDING DOORS

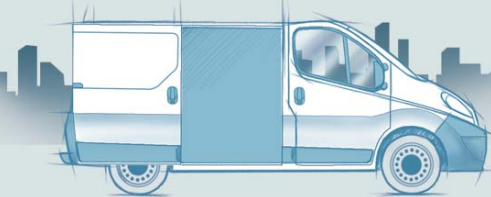

1 sliding door



2 sliding doors

VAN REAR DOORS

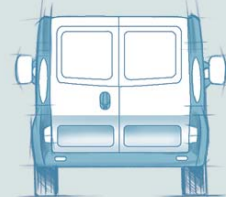

Panel rear doors (180° or 270°*)

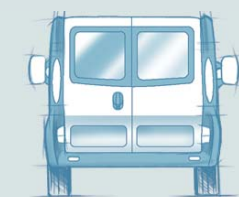

Glazed rear doors (180° or 270°*)

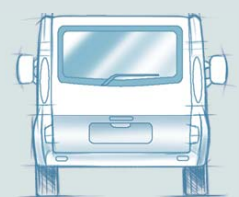

Tailgate

*270° rear doors only available on L2 vans

PASSENGER TRANSPORT BODY STYLES

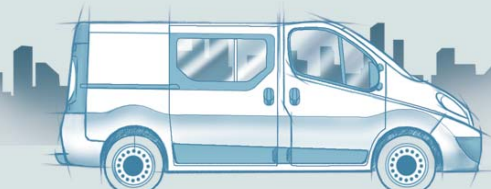

Crew van 6 seats L1H1 or L2H1 half-glazed

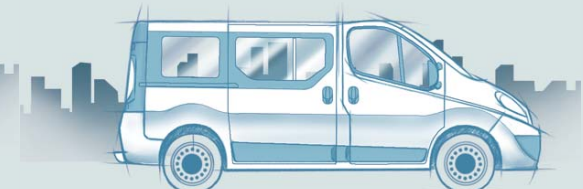

Minibus 9 seats L1H1 fully glazed

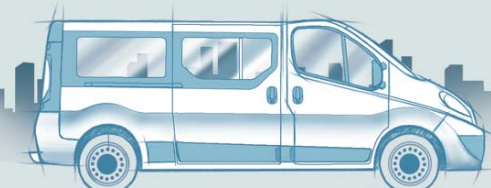

Minibus 9 seats L2H1 fully glazed

L1 = SWB, L2 = LWB

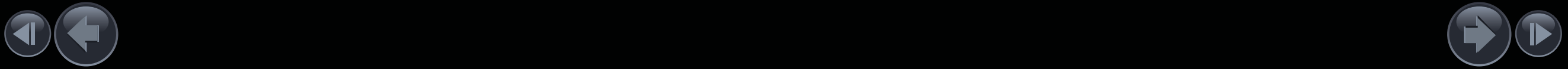

DIMENSIONS

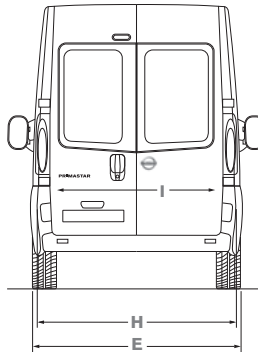
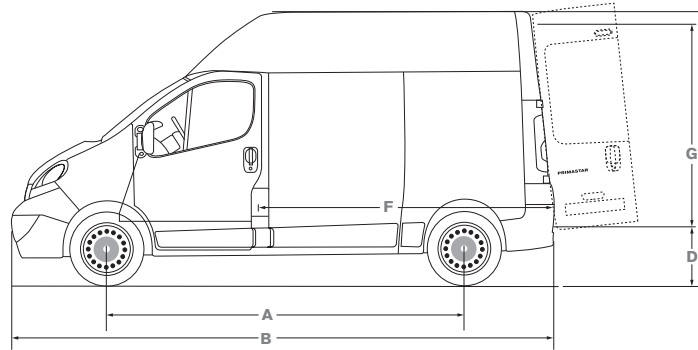
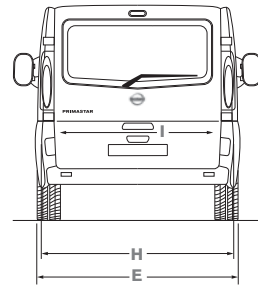
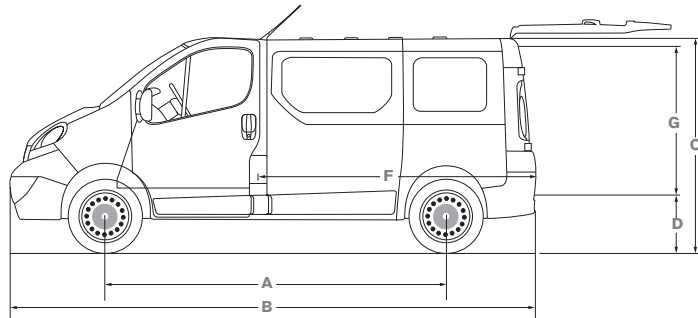
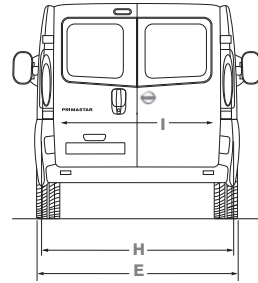
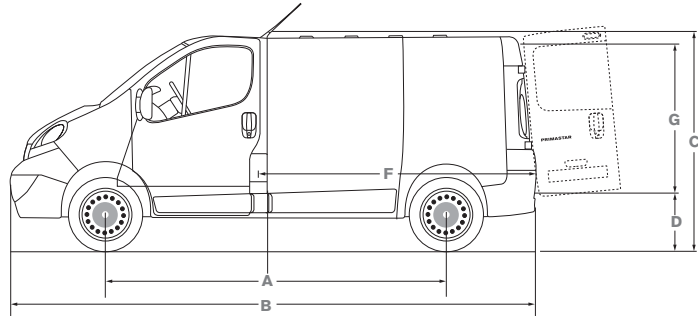

PRIMASTAR's compact external dimensions make it manoeuvrable for busy streets and let you slip into parking spaces other vans have to drive past. Yet highly efficient design ensures that, inside, PRIMASTAR offers a great deal of space.

Dimensions (mm)		VAN				MINIBUS			
		L1H1	L1H2	L2H1	L2H2	L1H1		L2H1	
						6 seats	9 seats	6 seats	9 seats
Wheelbase	A	3,098		3,498		3,098		3,498	
Overall Length	B	4,782		5,182		4,782		5,182	
Overall Height	C	1,955/1,963	2,492	1,962	2,477	1942/1963		1952/1968	
Load platform Height	D	534	547	533	525	540	535	538	532
Overall Width	E	1,904				1,904			
Cargo Length	F	2,400		2,800		1,548	790	1,948	1,190
Cargo Height	G	1,387	1,913	1,387	1,913	1,369			
Cargo Width	H	1,690				1,668			
Width between wheel arches	I	1,268				1,234			



COLOURS

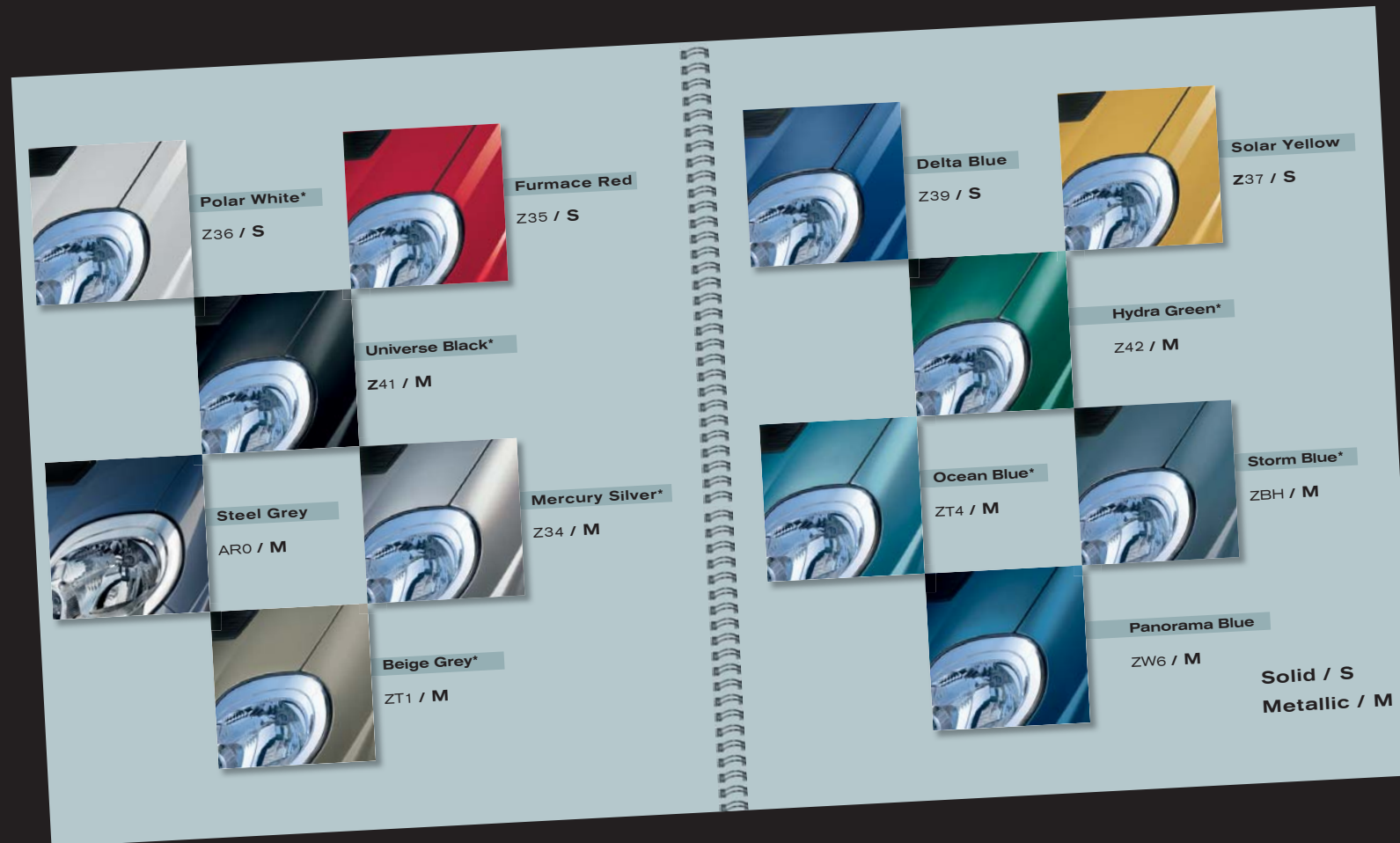

UPHOLSTERY

Seat trim Van and Minibus



WHEELS

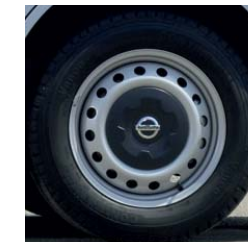

Standard steel wheel trim



Full wheel trim - SE+





01

PRIMASTAR ACCESSORIES



02



03

Our range of genuine accessories is the logical extension of PRIMASTAR's versatility. With these special accessories, you can precisely equip your vehicle for its intended role, knowing that the extras you choose are strongly made and specifically designed to enhance your PRIMASTAR.

Featured accessories:

- 02: Mudguards
- 03: Removable towbar
- 04: Microline window protection



04

Featured accessories:

01: The PRIMASTAR van accessorised with roof rack, roof rack platform and rear ladder.

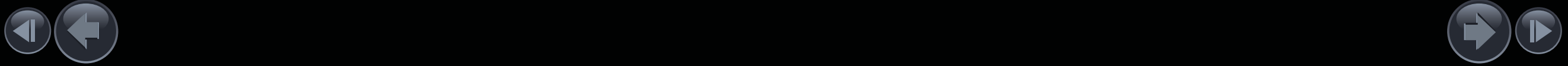

NISSAN COMMITMENT

If your van breaks down, it's a serious blow to your business. Even time allowed for servicing is downtime, when your van isn't earning its keep. At Nissan, we understand these hard business facts. So we do more to ensure your van stays where it belongs - working for you, on the road.

RELIABILITY BUILT-IN Exacting build standards and rigorous quality control mean that your PRIMASTAR is precision made, to uphold Nissan's renowned reputation for reliability. It's built to endure hard work and go long distances – 18,000 miles on the 2.0L dCi – between services.

PRIORITY SERVICE FOR OUR LCV CUSTOMERS Even though its visits to a Nissan workshop should be rare, you still want to be sure your PRIMASTAR benefits from expert and rapid attention. This is why it will be worked on by technicians who are dedicated to Nissan LCVs and therefore have the special knowledge required for fast and effective maintenance. When you contact your Nissan dealer, we guarantee that your PRIMASTAR will receive our expert attention promptly. This helps you plan routine servicing for a time that suits your business. And gives you the reassurance that any repairs needed will be undertaken with utmost priority.

NISSAN RAPID SERVICE A visit to the workshop is not always planned. But if you have a PRIMASTAR, there's no need to worry. Nissan Rapid Service means that participating dealers will take your vehicle and undertake key service items (economy service, tyres, brakes, exhaust, battery and shock absorbers) without an appointment, but always with a quoted price. These Nissan workshops have convenient opening hours, so they'll still be ready for your PRIMASTAR even after you've done a full day's work.

ROADSIDE ASSISTANCE Nissan offers a Pan European Roadside Assistance for the duration of your vehicle's warrant period. This service is available 24h a day, all year round, Sundays and public holidays included.

3-YEAR WARRANTY

You make commitments to your customers. And you can't afford to let them down. So at Nissan we do all we can to help you meet those commitments with vehicles that will stay on the road and on the job. PRIMASTAR is engineered to be ultra-reliable, with long service intervals and a host of support services such as out of hours servicing, specialist staff, Business Centres, and courtesy vans. PRIMASTAR, like all Nissan vans, is backed by a 3-year or 100,000mile (whichever is sooner) warranty. This comprehensively covers your new Nissan from defects in materials or workmanship.

12-YEAR ANTI-CORROSION WARRANTY 18,000-MILE SERVICE INTERVAL

ON 2.0dCi DIESEL VERSIONS

You and your PRIMASTAR will be out there whatever the weather. You'll drive on all types of surfaces. And you'll work in some very testing places. So you need a vehicle that can withstand everything it comes up against – again and again and again.

PRIMASTAR is finished in electrostatic paint and features under-body stone protection to guard against corrosion and damage. For your reassurance, PRIMASTAR's body is protected by a 12-year anti-corrosion warranty*.

* Yearly perforation from corrosion inspection must be carried out by an authorised Nissan dealer (independent of vehicle mileage)

[Introduction](#) | [Exterior](#) | [Comfort and technology](#) | [Performance](#) | [Safety](#) | [Load space](#) | [Combi Version](#) | [Equipment and Options](#)

[Print](#) | [Close](#)

[Finishing](#) | [Versions](#) | [Dimensions](#) | [Colours](#) | [Accessories](#) | [Technical Specification](#) | [Price List](#)





We see **SHIFT_** as an invitation. To challenge whatever feels too familiar. To open your mind to the unfamiliar. To ask the questions no-one else is asking. And to find answers no-one else can. At Nissan, we do this every day. And it shapes everything we do. The result is a line-up of vehicles that represents a pure, uncompromising shift from the ordinary.

Visit our website at:
www.nissan.co.uk
www.nissan-lcv.co.uk

Dealer stamp:



SHIFT_ the way you move

Every effort has been made to ensure that the content of this publication is correct at the time of going to press (December 2010). This brochure has been produced featuring prototype vehicles exhibited at motor shows. In accordance with the company's policy of continuously improving its products, Nissan Europe reserves the right to change at any time the specification and the vehicles described and shown in this publication. Nissan dealers will be informed of any such modifications as quickly as possible. Please check with your local Nissan dealer to receive the most up-to-date information. Because of the limitations of the printing processes used, the colours shown in this brochure may differ slightly from the actual colours of the paint and interior trim materials used. All rights reserved. Reproduction in whole or part of this brochure without the written permission of Nissan Europe is forbidden.

This brochure is made from chlorinefree paper - X83 GE-A 12/2010 - Printed in E.U. - PART NUMBER 99999-53126
 Created by NEW Robinson Creapress, France - Tel.: +33 1 40 62 37 37 and produced by EGRAPHICS\FRANCE, France - Tel.: +33 1 49 09 25 35.

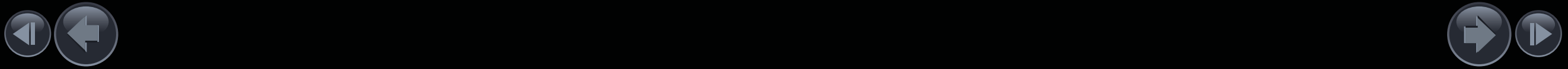



NISSAN PRIMASTAR
TECHNICAL SPECIFICATION



[Introduction](#) | [Exterior](#) | [Comfort and technology](#) | [Performance](#) | [Safety](#) | [Load space](#) | [Combi Version](#) | [Equipment and Options](#)

[Print](#) | [Close](#)

[Finishing](#) | [Versions](#) | [Dimensions](#) | [Colours](#) | [Accessories](#) | [Technical Specification](#) | [Price List](#)





PRIMASTAR GRADES

Primastar's car-like smoothness, precise steering and good visibility give excellent driver control under all conditions. Now with three grades to choose from Primastar offers the ideal van to suit your needs, whether you need a basic workhorse or comfortable cab loaded with car like features.

E GRADE

CARGO AREA ACCESSIBILITY

- Unglazed 180° opening rear doors
- Unglazed nearside (left) sliding door
- Side and rear door-activated loading lamps
- 6 x Floor mounted lashing rings

SAFETY AND SECURITY

- ABS
- Driver airbag
- 3-Point seatbelts (x2)
- Seatbelt pre-tensioners
- High mounted rear brake lamp
- 4 Disc brakes (ventilated front)
- Side-impact door bars
- 1/3 Tubular bulkhead behind driver
- Engine immobiliser and alarm
- Remote central locking
- Deadlocking
- 2-Button key

COMFORT AND CONVENIENCE

- Single CD player with steering wheel controls
- Aux input socket for MP3 players
- 3-Way adjustable driver's seat with height adjust
- Adjustable single passenger seat
- Tinted windows
- Power assisted steering
- Manual mirrors
- Manual windows
- Tachometer
- Intermittent wash-wipe (windscreen)
- Map lamp
- Dash-mounted gear lever
- Driver and passenger cup holders
- Door pocket with large bottle holder
- Glovebox with CD and sunglasses holder
- Bulkhead coats hooks in cabin

OPTIONS

- Metallic paint

SE GRADE ADDITIONAL TO E GRADE

SAFETY AND SECURITY

- Twin passenger seat with additional 3-point seatbelt

COMFORT AND CONVENIENCE

- 3-Button key with opening/locking of selective doors
- Full steel bulkhead
- Power windows
- Power and heated door mirrors
- Nissan Rear Park System (RPS)
- Trip computer
- Bluetooth

OPTIONS

- Metallic paint
- Power take-off
- Digital tachograph
- Off-side (right) unglazed sliding loading door

OPTION PACKS

- Comfort Pack
- Safety Pack
- Glazed Tailgate Pack
- Glazed Rear Doors Pack

SE+ GRADE ADDITIONAL TO SE GRADE

SAFETY AND SECURITY

- ESP
- Fog lamps
- Passenger airbag

COMFORT AND CONVENIENCE

- Air conditioning with pollen filter
- Automatic wipers and lights
- Full wheel trims
- Wooden floor liner
- Leather steering wheel
- Cruise control

OPTIONS

- Metallic paint



primastar

		MODEL																									
Length		Short Wheelbase					Long Wheelbase																				
Roof height		Low			High		Low			High																	
Engine		dCi115					dCi150		dCi115			dCi150															
Payload		1T			1.2T		1.2T																				
Transmission		manual	semi-auto	manual	semi-auto	manual	semi-auto	manual	semi-auto	manual	semi-auto	manual															
ENGINE																											
No. of cylinders		4																									
Valves per cylinder		4																									
Engine capacity		cm ³			1996		2464		1996			2464															
Bore x Stroke		mm			84x90		89x99		84x90			89x99															
Maximum engine power		hp			115		146		115			146															
		rpm			3500																						
Maximum torque		Nm			290		320		290			320															
		rpm			1600																						
Compression ratio		15.6:1			17.1:1		15.6:1			17.1:1																	
Fuel type		Diesel																									
Fuel supply		Direct Common Rail																									
Battery		Ah			85		95		85			95															
Alternator		Amps			150																						
DRIVE TRAIN																											
Transmission		6 Speed manual/6 Speed semi-automatic																									
Drive wheels		Front																									
CHASSIS																											
Suspension		Front			Independent, McPherson strut, coil springs, anti-roll bar																						
		Rear			Torsion beam axle, coil springs with progressive action, shock absorbers with variable damping and anti-roll bar																						
Steering		Rack and pinion, power assisted																									
Braking system (option)		Ventilated discs front : 305mm/28mm, plain discs rear : 280mm/12mm, Hydraulic braking and two independent circuits in "X", power assisted (EBD, 4 sensor ABS)																									
Wheel size		6 J 16																									
Tyre size		Standard			205/65		215/65		205/65																		
		Optional			215/65 R16; 205/65 R16AW				205/65 R16AW																		
PERFORMANCE																											
Maximum speed		km/h			160		150		160			170		150		170											
		mph			99.4		93.2		99.4			105.6		93.2		105.6											
Min. turning circle (kerb to kerb)		m			11.84																						
FUEL CONSUMPTION & EMISSIONS																											
Fuel Consumption		Urban Cycle		l/100 Km / MPG		8.5/33.2		8.5/33.2		8.5/33.2		9.5/29.73		8.5/33.2		8.5/33.2		10.5/26.9		9.5/29.73		8.6/32.85		10.5/26.9			
		Extra Urban		l/100 Km / MPG		6.8/41.5		6.6/42.8		6.8/41.5		6.6/42.8		7.6/37.17		6.8/41.5		6.6/42.8		7.7/36.69		7.6/37.17		7.6/37.17		7.7/36.69	
		Combined		l/100 Km / MPG		7.4/38.2		7.3/38.7		7.4/38.2		7.3/38.7		8.3/34.03		7.4/38.2		7.3/38.7		8.8/32.10		8.3/34.03		8/35.31		8.8/32.10	
CO ₂ mas Emission (Combined)		gr/Km		195		192		195		192		220		195		192		232		220		210		232			

		MODEL													
Length		Short Wheelbase					Long Wheelbase								
Roof height		Low			High		Low			High					
Engine		dCi115					dCi150		dCi115			dCi150			
Payload		1T			1.2T		1.2T								
Transmission		manual	semi-auto	manual	semi-auto	manual	semi-auto	manual	semi-auto	manual	semi-auto	manual			
WEIGHTS															
Kerb weight		Min.	kg	1678	1690	1688	1701	1760	1724	1737	1772	1810	1823	1860	
Gross vehicle weight		kg		2770	2735	2935	2945	2920	2960	2930	3035	3010	3025	3065	
Maximum payload*		kg		1092	1045	1247	1244	1160	1236	1193	1263	1200	1202	1205	
Gross axle weight		Front		kg			1450		1580			1580		1620	
		Rear		kg			1550		1650			1650		1650	
Max trailer weight (1)		Braked		kg									2000		
		Unbraked		kg									750		
OVERALL DIMENSIONS															
Length		mm		4782					5182						
Width		mm		1904					1904						
Height (unladen)		Min.		mm		1955		1963		2465		1962		2464	
Wheelbase		mm		3098					3498						
Overhang		Front		mm			833								
		Rear		mm			851								
Track		Front		mm			1615								
		Rear		mm			1630								
Ground clearance (unladen)		mm		168	177	178	177	178	181	177	174				
CARGO AREA DIMENSIONS															
Maximum length		mm		2400					2800						
Maximum width		mm		1690					1690						
Maximum height		mm		1387			1913		1387			1913			
Maximum width between wheel arches		mm		1268					1268						
Maximum load platform height		mm		534			527		533			525			
Cargo volume		m ³		5.02			7.09		5.94			8.36			
Side door		Width		mm			1000								
		Height		mm			1285								
Back door		Width		mm			1390								
		Height		mm			1335		1818		1335		1818		
FUEL TANK															
Capacity		l		90											

*GVW minus unladen weight (driver and crew weight must be subtracted).

(1) When a vehicle is fitted with a towbar, it is recommended that a tachograph is fitted, since the ability to tow a trailer giving a Gross Train Weight (GVW + Trailer Weight) of over 3,500Kg without a tachograph could be considered to be contrary to EU and UK road traffic legislation.

PRIMASTAR				
Dimensions (mm)	Van			
	SWB Low	SWB High	LWB Low	LWB High
Wheelbase	A	3098		3498
Overall length	B	4782		5182
Overall height	C	1955* 1963**	2465	1962 2464
Sill height	D	534	527	533 525
Overall width	E	1904		
Cargo length	F	2400		2800
Cargo height	G	1387	1913	1387 1913
Cargo width	H	1690		
Width between wheel arches	I	1268		

*1.0 tonne payload models
**1.2 tonne payload models

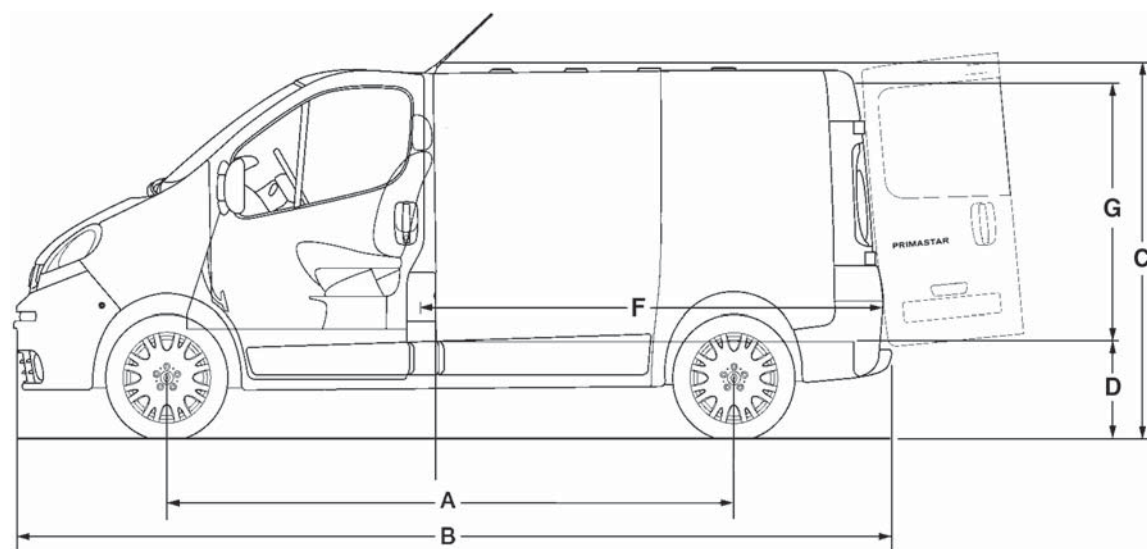
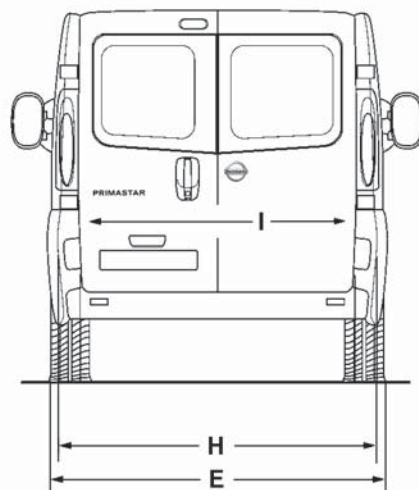



MINIBUS GRADES

The Primastar Minibus is the stylish way to transport up to eight passengers. With the responsiveness of a car and a highly effective braking system of all round disc brakes with ABS and EBD, driver or passenger, everybody can enjoy the ride of the Primastar Minibus. With the availability of several optional extras, it's easy to make the most of the Primastar Minibus, whatever your business; whatever your needs.

SE GRADE

CARGO AREA ACCESSIBILITY

- Rear glazed tailgate
- No bulkhead
- Side and rear door-activated loading lamps
- Rear load area rubber floor covering
- Double sliding doors with opening windows
- Rear wiper
- Heated rear window

SAFETY AND SECURITY

- Driver airbag
- Passenger airbag
- Seatbelt pre-tensioners
- High mounted rear brake lamp
- ABS with EBD and EBA
- Panoramic door mirrors
- Side impact door bars
- 4 Disc brakes (ventilated front)
- Nissan Rear Park System (RPS)
- Immobiliser and alarm
- Remote central locking
- Deadlocking
- 3-Button key

COMFORT AND CONVENIENCE

- Single CD player with steering wheel controls
- Aux input socket for MP3 players
- 3-Way adjustable driver seat and height adjust
- Twin passenger seat-bench with additional 3-point seatbelt
- Removable 2nd row of seats (bench - 3 seats)
- Foldable and removable 3rd row of seats (bench - 3 seats)
- Power assisted steering
- Reach adjustable steering wheel
- One-touch power windows
- Power and heated door mirrors
- Front body coloured bumper - partly coloured
- 3rd Row area with windows
- Trip computer
- Bluetooth

OPTIONS

- Metallic paint
- Digital tachograph and towbar

OPTION PACKS

- Comfort Pack
- Safety Pack

PRIMASTAR MINIBUS			
Dimensions (mm)		Minibus	
		SWB Low	LWB Low
Wheelbase	A	3098	3498
Overall length	B	4782	5182
Overall height	C	1942 - 1963	
Sill height	D	535	532
Overall width	E	1904	
Cargo length	F	2360/1548/744	2760/1948/1144
Cargo height	G	1369	
Cargo width	H	1678	
Width between wheel arches	I	1234	

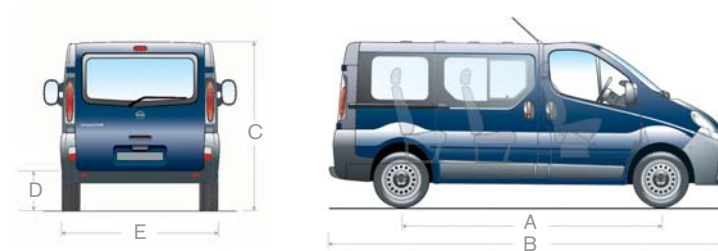

minibus

		MODEL						
		Short Wheelbase			Long Wheelbase			
Length		Low			Low			
Roof height		Low						
Engine		dCi115	dCi150	dCi115	dCi150			
Gross vehicle weight		2900						
Seats		9 Seats						
Transmission		manual	semi-auto	manual	manual	semi-auto	manual	
ENGINE								
No. of cylinders		4						
Valves per cylinder		4						
Engine capacity	cm3	1996	2464	1996	2464			
Bore x Stroke	mm	84x90	89x99	84x90	89x99			
Maximum engine power	hp	115	146	115	146			
	rpm	3500						
Maximum torque	Nm	290	320	290	320			
	rpm	1600	1500	1600	1500			
Compression ratio		15.19:1	18:1	15.19:1	18:1			
Fuel type		Diesel						
Fuel supply		Direct Common Rail						
Battery	Ah	85	95	85	95			
Alternator	Amps	150						
DRIVE TRAIN								
Transmission		6 speed manual/6 speed semi-automatic						
Drive wheels		Front						
CHASSIS								
Suspension	Front	Independent, McPherson strut, coil springs, anti-roll bar						
	Rear	Torsion beam axle, coil springs with progressive action, shock absorbers with variable damping and anti-roll bar						
Steering		Rack and pinion, power assisted						
Braking system (option)		Ventilated discs front : 305mm/28mm, plain discs rear : 280mm/12mm, Hydraulic braking and two independent circuits in "X", power assisted (EBD, 4 sensor ABS)						
Wheel size		6 J 16						
Tyre size		205/65 R16C	215/65 R16	205/65 R16C	215/65 R16			
PERFORMANCE								
Maximum speed	km/h	160	170	160	170			
	mph	99.4	105.6	99.4	105.6			
Min. turning circle (kerb to kerb)	m	11.84			13.17			
FUEL CONSUMPTION & EMISSIONS								
Fuel Consumption	Urban Cycle	l/100 Km / MPG	9.2/30.70	8.5/33.23	10.5/26.90	9.2/30.70	8.5/33.23	10.5/26.90
	Extra-Urban	l/100 Km / MPG	6.8/41.54	7.0/40.35	7.7/36.69	6.8/41.54	7.0/40.35	7.7/36.69
	Combined	l/100 Km / MPG	7.7/36.69	7.5/37.66	8.8/32.10	7.7/36.69	7.5/37.66	8.8/32.10
CO2 mas Emission (Combined)	gr/Km	203	199	232	203	199	232	

		MODEL					
		Short Wheelbase			Long Wheelbase		
Length		Low			Low		
Roof height		Low					
Engine		dCi115	dCi150	dCi115	dCi150		
Gross vehicle weight		2900					
Seats		9 Seats					
Engine capacity		manual	semi-auto	manual	manual	semi-auto	manual
WEIGHTS*							
Kerb weight	Min. kg	1893	1908	1942	1954	1968	2002
Gross vehicle weight		2920	2930	2970	3040	3050	3070
Maximum payload*		1027	1022	1028	1086	1082	1068
Gross axle weight	Front kg	1580			1620		
	Rear kg	1650					
Max trailer weight (1)	Braked kg	2000					
	Unbraked kg	750					
OVERALL DIMENSIONS							
Length	mm	4782			5182		
Width (Excluding side mirrors)	mm	1904					
Height (unladen)	Min. mm	1942	1958	1952	1954		
Wheelbase	mm	3098			3498		
Overhang	Front mm	833					
	Rear mm	851					
Track	Front mm	1615					
	Rear mm	1630					
Ground clearance (unladen)	mm	180	183	179	177		
CARGO AREA DIMENSIONS							
Maximum length	mm	2360/1548/744			2760/1948/1144		
Maximum width	mm	1678					
Maximum height	mm	1369					
Maximum width between wheel arches	mm	1234					
Maximum load platform height	mm	535	541	532	540		
Cargo volume	m3	1.24			2.15		
Side door	Width mm	1000					
	Height mm	1285					
Back door	Width mm	1390					
	Height mm	1306					
FUEL TANK							
Capacity	l	90					

*Weights and dimensions for 3 seats/6 seats/9 seats versions without options, driver and passengers, including coolant, oils, spare wheel, tools and 90% full fuel.

*GVW minus unladen weight (driver and crew weight must be subtracted).

(1) When a vehicle is fitted with a towbar, it is recommended that a tachograph is fitted, since the ability to tow a trailer giving a Gross Train Weight (GVW + Trailer Weight) of over 3,500Kg without a tachograph could be considered to be contrary to EU and UK road traffic legislation.



[Introduction](#) | [Exterior](#) | [Comfort and technology](#) | [Performance](#) | [Safety](#) | [Load space](#) | [Combi Version](#) | [Equipment and Options](#)

[Print](#) | [Close](#)

[Finishing](#) | [Versions](#) | [Dimensions](#) | [Colours](#) | [Accessories](#) | [Technical Specification](#) | [Price List](#)



PRIMASTAR VAN - (Prices effective from 1st July 2011)

Wheelbase	Engine	Roof	GVW (kg)	Grade	Power	Payload (kg)	Transmission	Basic Delivered	VED + 1st Reg	Basic On The Road
Short	2.0 dCi	Low	2,700	E	115HP	1,000	6 manual	16,380	265	16,645
	2.0 dCi	Low	2,700	SE	115HP	1,000	6 manual	16,880	265	17,145
	2.0 dCi	Low	2,700	SE+	115HP	1,000	6 manual	17,980	265	18,245
	2.0 dCi	Low	2,700	SE	115HP	1,000	6 Semi-auto	17,680	265	17,945
	2.0 dCi	Low	2,700	SE+	115HP	1,000	6 Semi-auto	18,780	265	19,045
	2.0 dCi	Low	2,900	E	115HP	1,200	6 manual	16,780	265	17,045
	2.0 dCi	Low	2,900	SE	115HP	1,200	6 manual	17,280	265	17,545
	2.0 dCi	Low	2,900	SE+	115HP	1,200	6 manual	18,380	265	18,645
	2.0 dCi	Low	2,900	SE	115HP	1,200	6 Semi-auto	18,080	265	18,345
	2.0 dCi	Low	2,900	SE+	115HP	1,200	6 Semi-auto	19,180	265	19,445
	2.0 dCi	High	2,900	E	115HP	1,200	6 manual	17,480	265	17,745
	2.0 dCi	High	2,900	SE	115HP	1,200	6 manual	17,980	265	18,245
	2.0 dCi	High	2,900	SE+	115HP	1,200	6 manual	19,080	265	19,345



Wheelbase	Engine	Roof	GVW (kg)	Grade	Power	Payload (kg)	Transmission	Basic Delivered	VED + 1st Reg	Basic On The Road
Long	2.0 dC	Low	2,900	E	115HP	1,200	6 manual	17,580	265	17,845
	2.0 dCi	Low	2,900	SE	115HP	1,200	6 manual	18,080	265	18,345
	2.0 dCi	Low	2,900	SE+	115HP	1,200	6 manual	19,180	265	19,445
	2.0 dCi	Low	2,900	SE	115HP	1,200	6 Semi-auto	18,880	265	19,145
	2.0 dCi	Low	2,900	SE+	115HP	1,200	6 Semi-auto	19,980	265	20,245
	2.0 dCi	High	2,900	E	115HP	1,200	6 manual	18,280	265	18,545
	2.0 dCi	High	2,900	SE	115HP	1,200	6 manual	18,780	265	19,045
	2.0 dCi	High	2,900	SE+	115HP	1,200	6 manual	19,880	265	20,145
	2.0 dCi	High	2,900	SE	115HP	1,200	6 Semi-auto	19,580	265	19,845
	2.0 dCi	High	2,900	SE+	115HP	1,200	6 Semi-auto	20,680	265	20,945
	2.5 dCi	Low	2,900	SE	150HP	1,200	6 manual	19,280	265	19,545
	2.5 dCi	Low	2,900	SE+	150HP	1,200	6 manual	20,380	265	20,645
	2.5 dCi	High	2,900	SE	150HP	1,200	6 manual	19,980	265	20,245
	2.5 dCi	High	2,900	SE+	150HP	1,200	6 manual	21,080	265	21,345

PRIMASTAR CREW VAN* - (Prices effective from 1st July 2011)

Wheelbase	Engine	Roof	GVW (kg)	Grade	Power	Payload (kg)	Transmission	Basic Delivered	VED + 1st Reg	Basic On The Road
Short	2.0 dCi	Low	2,900	SE	115HP	1,200	6 manual	19,380	265	19,645
Long	2.0 dCi	Low	2,900	SE	115HP	1,200	6 manual	20,180	265	20,445

The Basic Delivered price excludes VAT but includes delivery to the dealership and number plates. The Basic On The Road price excludes VAT but includes delivery to the dealership, number plates, 12 months Vehicle Excise Duty (£210) and Government First Registration Fee of £55.

* Special build conversions may be subject to extended delivery.



PRIMASTAR OPTIONS - (Prices effective from 1st July 2011)

	E	SE	SE+	Crew Van SE	Basic Price
Metallic paint	○	○	○	○	350
Power Take-Off (not compatible with air con or semi auto transmission)		○			120
Digital Tachograph		○			500
Offside (right) Sliding Door		○		●	250
Loading ladder (prices from)	□	□	□	□	115.88
Roof rack (prices from)	□	□	□	□	517.98
Single roof bar	□	□	□	□	103.10
Towbar (fixed) and single electrics	□	□	□	□	306.25
OPTION PACKS					
Comfort Pack		○			675
- Air Conditioning with Pollen Filter					
- Driver Seat Armrest					
- Front Fog Lamps					
- Intelligent Wipers					
- Automatic Lighting System					
Safety Pack		○			500
- Front Fog Lamps					
- Passenger Airbag					
- ESP					
Glazed Tailgate Pack		○			250
- Rear Glazed Tailgate with Wiper					
- Heated Rear Windows					
- Glazed Bulkhead with Rearview Mirror					
Glazed Rear Doors Pack - with Glazed Bulkhead		○			
- Glazed Rear Doors 180° Opening with Wiper					
- Glazed Bulkhead and Interior Rearview Mirror					
- Heated Rear Windows					

For latest information on options that can be combined together, please contact your local Nissan Dealer.
 Dealer fit option prices include fitting but are only a guide. Please check with your local Nissan dealer for exact prices.

Optional - ○ Standard - ● Optional Dealer Fit - □





PRIMASTAR MINIBUS - (Prices effective from 1st July 2011)

Wheelbase	Engine	Roof	GVW (kg)	Grade	Power	Transmission	Basic Delivered	VAT	Total Retail	On The Road
Short	2.0 dCi	Low	2,900	SE	115HP	6 manual	19,550	3,910	23,460	24,095
Short	2.0 dCi	Low	2,900	SE	115HP	6 Semi-auto	20,350	4,070	24,420	25,055
Short	2.5 dCi	Low	2,900	SE	150HP	6 manual	20,750	4,150	24,900	25,745
Long	2.0 dCi	Low	2,900	SE	115HP	6 manual	20,350	4,070	24,420	25,055
Long	2.0 dCi	Low	2,900	SE	115HP	6 Semi-auto	21,150	4,230	25,380	26,015
Long	2.5 dCi	Low	2,900	SE	150HP	6 manual	21,550	4,310	25,860	26,705

Basic and Total Retail prices include delivery to the Dealership and number plates. On The Road price includes 12 months Government Vehicle Excise Duty (£580 on 2.0 and £790 on 2.5) and Government First Registration fee of £55.



PRIMASTAR MINIBUS OPTIONS - (Prices effective from 1st July 2011)

	SE	Basic Price	VAT	Total
Metallic paint	<input type="radio"/>	350	70	420
Digital Tachograph and Towbar	<input type="radio"/>	825	165	990
Loading Ladder	<input type="checkbox"/>	115.88	23.18	139.06
Roof Rack	<input type="checkbox"/>	517.98	103.60	621.58
Single roof bar	<input type="checkbox"/>	103.10	20.62	123.72
OPTIONS PACKS				
Comfort Pack	<input type="radio"/>	1,250	250	1500
- Air Conditioning (front & rear) + Pollen Filter				
- Front Armrest				
- Intelligent Wipers				
- Automatic Lighting System				
- Front Fog Lamps				
Safety Pack	<input type="radio"/>	750	150	900
- Rear Airbag				
- Front Side Airbags				
- Front Fog Lamps				
- ESP (on manual gearbox variants)				
- Intelligent Wipers				
- Automatic Lighting System				

Dealer fit option prices include fitting but are only a guide. Please check with your local Nissan dealer for exact prices

Optional - Optional Dealer Fit -



NISSAN VAN INSURANCE

Did you know you can insure your van through Nissan Insurance?

With Nissan Van Insurance, you can be sure that you'll get the right cover at a great price. You'll also be dealing with people who really understand the way your business works. We know you want to save money, so our premiums are price-matched against the UK's leading insurers to give you great value.

Benefits include:

- Fully comprehensive cover available for virtually any type of business use
- 24/7 accident recovery helpline
- Discounts for branded vans and fixtures such as ladder holders
- Windscreen cover included as standard
- All repairs carried out in a Nissan dealership/Nissan approved repair centre
- All repairs carried out using Nissan Genuine Parts
- Like-for-like replacement provided if your vehicle is written off in the first 12 months

Call for a quote today on **0800 011 3528** and find out just how much money you could save with Nissan Van Insurance.

All quotes are based on individual circumstances and are subject to insurer's underwriting criteria. Terms and conditions apply, Nissan Insurance is arranged and administered by Equity Insurance Brokers Limited, which is authorised and regulated by the Financial Services Authority. Registered Office: Library House, New Road, Brentwood, Essex CM 14 4GD. Registered in England No. 258414. Nissan Motor (GB) Limited is authorised and regulated by the Financial Services Authority.



FURTHER INFORMATION

Price Protection Plan. Order a new Nissan for delivery no more than 4 weeks in advance and the price you are quoted is the price you pay. This is irrespective of any subsequent price rises between placing your order and delivery of your new vehicle. Nissan Motor (GB) is not liable for price adjustments caused by Government changes in the rate of VAT or by any other applicable legislation or regulation or Vehicle Excise Duty.

Pathfinder Van & Navara - Three year/60,000 miles manufacturer's warranty - Nissan's comprehensive warranty provides cover for your new Nissan from defects in materials or workmanship. Your vehicle is covered in all European Countries where Authorised Nissan Dealers are located. If your vehicle becomes inoperative due to warrantable defects, a towing service, when necessary, to the Authorised Dealer is covered. If a warrantable defect abroad takes more than six hours to repair, the Touring Assistance Programme will pay for a hotel or rental car to a certain maximum. The paint warranty covers painted body parts (excluding the underbody) for three years regardless of mileage driven. For further details please contact your local Authorised Nissan Dealer.

LCV model (including NV200, Primastar, Interstar and Cabstar) - New Vehicle Warranty is issued by Nissan International SA is valid for 3 years from the warranty start date or 60,000 miles, whichever comes first. In addition, for each new LCV model (including NV200, Primastar, Interstar and Cabstar) sold by an authorised UK Nissan dealer, Nissan Motor (GB) Limited (NMGB) will issue an extension to the New Vehicle Warranty. This warranty extension will cover your vehicle from 60,000 miles up to 100,000 miles or 3 years from the warranty start date, whichever comes first. Please note that audio and navigation units will not be covered by the warranty extension.

Special build conversions may be subject to extended delivery.

The conversions in this price list are from Nissan Motor GB-appointed converters and have warranty terms in line with the Nissan Pan European Warranty. The converter is responsible for all aspects of the conversion.

Nissan European Roadside Assistance is provided for the first three years of your van's life. Please see www.nissan-assistance.co.uk for full details including terms and conditions.

Recyclability - we take our environmental responsibilities very seriously - innovation today comes with a deep respect for the environment. Our engines are now much more unobtrusive and their emissions have been considerably reduced. All our vehicles are designed with recycling in mind.

All prices in this list are quoted in pounds sterling. Value Added Tax (VAT) has been calculated at 20%. Accessory prices are subject to change, please see your nearest dealership for the most up to date prices.

While all reasonable effort has been made to ensure the accuracy of the information provided, due to Nissan's policy of continuous product improvement, all particulars contained are subject to constant revision and Nissan reserves the right to change, alter or modify among other things, specifications, colours and prices of models without notice at any time. Accordingly you should consult your local Nissan Dealer for the exact introduction dates of all models and for the most up-to-date information.





YOU + NISSAN

CARE

You care about the car you drive. So do we. That's why we're making a commitment to providing the best customer service in the market.

Find out more nissan.co.uk/care



Nissan cares for you because you care about your Nissan.
That's why we'll make the following commitment:

YOU care about staying on the road when your Nissan is in for service or repair.

YOU care about quality enough to have your Nissan serviced at a Nissan dealership.

YOU care about getting the best value for money when it comes to service and repair.

YOU care about having your problems resolved quickly.

YOU care about getting the right Nissan model, engine & gear box to test drive.

NISSAN will keep you mobile free of charge.

NISSAN says thanks by giving you continuous Nissan roadside assistance for free.

NISSAN will price match like for like competitor written quotes within 10 miles of your local dealer.

NISSAN will propose how to resolve any problem within 2 working days.

NISSAN will guarantee that's what you'll get when you pre-book your test drive either online or through our customer service centre.

Find out more nissan.co.uk/care





SHIFT_ is an English word from a Japanese car company that best embraces our values and the mission of this corporation. No matter where you are in the world, SHIFT_ is the way to express who we are, how we work and what we are trying to accomplish.

Everything we touch, we SHIFT_ and everything we SHIFT_ we try to make better and uniquely Nissan.

Visit our websites at:
www.nissan.co.uk
www.nissan-lcv.co.uk

Dealer stamp:



SHIFT_ the way you move

We take all our environmental responsibilities very seriously – innovation today comes with a deep respect for the environment. Our engines are now much more unobtrusive and their emissions have been considerably reduced. All our vehicles are designed with recycling in mind and are on target to reach 95% recyclability. This brochure is for general guidance only and its contents do not in any way constitute an offer or representation from Nissan. Every effort has been made to ensure the content of this publication is correct at the time of going to press (October 2010). In accordance with the company's policy of continuously improving its products, Nissan reserves the right to change at any time the specification and the vehicles described and shown in this publication. Nissan dealers will be informed of any such modifications as quickly as possible. Please check with your local Authorised Nissan Dealer to receive the most up-to-date information. Because of the limitations of the printing processes used, the colours shown in this brochure may differ slightly from the actual colours of the paint and interior trim materials used. All rights reserved. Reproduction in whole or part of this brochure without the written permission of Nissan is forbidden.

Benefits and services are provided by RAC Motoring Services and/or RAC Insurance Limited. RAC Motoring Services (Company No. 01424399, Head Office: 8 Surrey Street, Norwich, NR1 3NG) in respect of insurance mediation activities only and RAC Insurance Limited (Company No. 2355834, Head Office: 8 Surrey Street, Norwich, NR1 3NG) are authorised and regulated by the Financial Services Authority within the jurisdiction of the Financial Ombudsman Service and the Financial Services Compensation Scheme. Calls may be monitored and/or recorded. Roadside Assistance has been arranged for you by Nissan and is provided by RAC free of charge. Details of the contractual arrangements under which RAC Services are provided to you are available by calling 0870 366 5603.

Part number 99999-53125

