

# F-TYPE





**“THE CAR**

IS THE CLOSEST THING WE WILL EVER CREATE TO SOMETHING THAT

**IS ALIVE”**

SIR WILLIAM LYONS

## CONTENTS

DESIGN  
Pages 4 - 17

PERFORMANCE  
Pages 18 - 25

TECHNOLOGY  
Pages 26 - 51

F-TYPE R  
Pages 52 - 61

YOUR F-TYPE  
Pages 62 - 95

## SO DISTINCTIVE, SO INSTINCTIVE, AND SO ALIVE

**"The car is the closest thing we will ever create to something that is alive."**

**The words of Jaguar's founder, Sir William Lyons, combine the three strands of Technology, Performance and Design which form our Alive DNA. His uncompromising vision of continually setting ever higher benchmarks is the philosophy that we still live by today.**

**Alive Technology** creates the feeling that a Jaguar car is alive. Every innovation is developed to provoke a driving experience that always feels instinctive.

**Alive Performance** is constantly evolving for greater power, efficiency and refinement.

**Alive Design** pushes the boundaries of what is possible by ensuring that in every Jaguar engineering and beauty coalesce like no other.





# F-TYPE

We can't just call it F-TYPE, we have to make it F-TYPE. It has to look, feel and drive like a true Jaguar sports car, the latest in a distinguished bloodline. An F-TYPE has to be powerful, agile and utterly distinctive.

Coupé or Convertible, manual or automatic gearbox, every F-TYPE is built to embody Jaguar's legendary state-of-the-art handling dynamics, outstanding alive performance, and cutting-edge technology which delivers an unparalleled sports driving experience.

A prodigious range of new F-TYPE options includes All Wheel Drive with Intelligent Driveline Dynamics, for even greater performance capabilities, and advanced InControl connected cabin technologies. Now, more than ever, you can choose an F-TYPE to suit your needs and your desires.

Powerful supercharged engines and lightning-fast responsiveness; lightweight aluminium body construction and an obsession with balance and proportion; sophisticated suspension and a host of advanced driving technologies; unrivalled design and driver-focused cockpits. The F-TYPE range offers a uniquely connected driving experience, they're the sports cars that only Jaguar could create - ultra-precise, powerful, sensual and, most of all, alive.

F-TYPE COUPÉ AND CONVERTIBLE

F-TYPE S COUPÉ AND CONVERTIBLE

F-TYPE S AWD COUPÉ AND CONVERTIBLE

F-TYPE R COUPÉ AND CONVERTIBLE

F-TYPE R AWD COUPÉ AND CONVERTIBLE

VEHICLE SHOWN ON FRONT COVER: F-TYPE R AWD IN STORM GREY WITH OPTIONAL SPORT DESIGN PACK, CARBON FIBRE ROOF, STORM ALLOY WHEELS AND CARBON CERAMIC BRAKES  
VEHICLE SHOWN LEFT AND ON BACK COVER: F-TYPE S IN CALDERA RED

## YOUR PERFECT F-TYPE

F-TYPE's technical excellence delivers a breadth of capabilities to suit the road, the conditions and the demands of the driver. Coupé or Convertible: both forms are available in three model types offering distinctive characteristics to suit the individual sports car driver.

**F-TYPE** is designed to deliver pure driving pleasure. It combines effortless, exhilarating performance, instant response and precise agile handling, with everyday refinement and usability.

**F-TYPE S** and **F-TYPE S AWD** add greater power and an increased range of sophisticated driving technologies.

**F-TYPE R** and **F-TYPE R AWD** deliver supercar levels of performance combined with advanced dynamic technologies for the ultimate driver-focused experience.

Every F-TYPE is equally at home whether taking hairpin bends on mountain passes, cruising on the motorway or gliding through the city. With Jaguar's astonishing F-TYPE range, there's one that's perfect for you.

VEHICLE SHOWN: F-TYPE S IN AMMONITE







KBS 257

F-TYPE

JAGUAR

P



# IN THE LINE OF BEAUTY

F-TYPE's powerful shape and beautiful proportions define its essence as a performance sports car. Its head-turning style has already earned international acclaim, winning the World Car Awards' Design of the Year.

**"A piece of design should tell a story and this is why every line in F-TYPE has a start, a direction and a conclusion. If you approach every line individually and get it as aesthetically correct as possible, get the dimensions right, it will stand the test of time."**

Ian Callum, Jaguar Design Director

# LIGHTWEIGHT ALUMINIUM CONSTRUCTION



**STRONG AND RIGID**

**HIGH POWER-TO-WEIGHT AND TORQUE-TO-WEIGHT RATIOS**



Jaguar has been at the forefront of aluminium car construction for more than a decade and continues to push the boundaries of the technology. A lightweight aluminium body structure with high torsional rigidity is the ideal platform for a sports car, and is fundamental to the way F-TYPE performs, handles and feels. A strong, stiff structure provides an inherently stable platform for precise, agile handling and allows the finely-tuned suspension system to deliver connectivity and driver feedback. F-TYPE's body is the perfect complement to its high-performance engine range. Together they produce the exceptional power-to-weight and torque-to-weight ratios that deliver the real world measures of performance in a sports car.

The aluminium exterior panels are constructed from specially developed alloys that combine robustness and quality of finish with much greater formability for greater clarity and tightness of radii and feature lines. On Coupé models, the side pressing is one of the most technically advanced in the automotive industry and results in cleaner lines with an extraordinarily beautiful, uninterrupted sweep from the A pillar all the way to the trailing edge. Whichever F-TYPE you choose, the use of advanced materials and innovative techniques allowed Jaguar's engineers to reproduce F-TYPE's beautifully crisp, crafted lines exactly as the designers had intended, as well as delivering a vehicle with extraordinary structural integrity.





# ON BALANCE



**OPTIMUM WEIGHT  
DISTRIBUTION**

**LOW CENTRE  
OF GRAVITY**

**PERFECT  
PROPORTIONS**

It is essential in the design of a great sports car that weight is kept to a minimum, is evenly distributed front to rear and that the centre of gravity is kept as low as possible. This configuration in F-TYPE means that the car has natural balance and is the result of meticulous attention to detail during the design and construction of the body structure. An uncompromising focus on weight distribution achieves the optimum balance between front and rear wheels, with items such as the battery, electronic systems and even the washer bottle located at the rear of the car.

A shorter car is more agile; a wider car is more stable. The relationship between F-TYPE's length of 4,470mm and width of 1,923mm was precisely engineered to deliver inherent agility and means that the car has outstanding driving dynamics. Its low centre of gravity reduces body roll in corners, while short front and rear overhangs mean that the mass is concentrated within the wheelbase. These essential factors combine to ensure that F-TYPE is inherently agile.

## MASS MOMENT OF INERTIA

The closer the weight is to the centre of the car, the easier it is to turn the car.

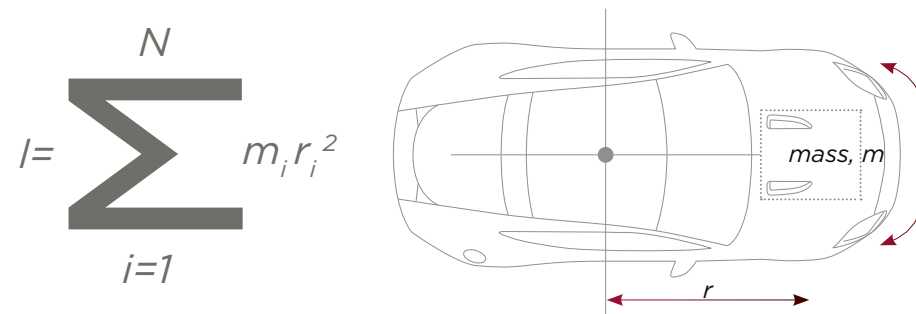



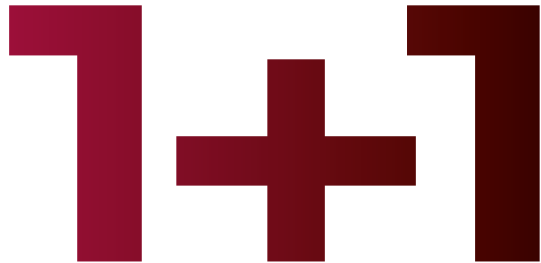

## DRIVER FOCUS

F-TYPE comes alive when car and driver connect. Its 1+1 configuration is designed to wrap around you, to create a bond, taking your driving experience to greater heights. You and F-TYPE become one.

The cockpit's design provides visibility, minimal distractions and close-to-the-centre-of-gravity seating with rigid seat frames and structure. The facia has been kept as low as possible and free from clutter to increase the forward view. The **Intelligent Venting System**, part of the advanced climate control system, hides the twin central air vents which automatically deploy when required, rising from the dashboard and retracting after use.

Two seat styles are available, the standard **Sports Seat**, and an optional **Performance Seat**, offering enhanced lateral support during rapid cornering and upholstered in Premium leather. For the ultimate in luxury, all models can also be specified with the optional **Premium leather interior**, which adds leather to the upper facia, centre console and door casings. Premium leather interior with twin needle stitching and Performance Seats are standard on F-TYPE R.





## DRIVER ORIENTATED CONTROLS

F-TYPE's advanced control technology keeps things simple so you can concentrate on the drive. It presents information to you only as necessary or when requested. Instruments are uncomplicated, clear and easy to read featuring two large analogue dials – essential in a sports car.

F-TYPE's steering wheel features a three-spoke design which incorporates key controls. On models fitted with the Quickshift 8-speed automatic gearbox, gearshift paddles mounted behind the spokes provide manual control without the need for you to take your hands from the wheel. On the centre console, the gearbox's **SportShift Selector** is simple and intuitive to use. It offers full Auto mode plus, in Sports mode, manual operation. This allows you to select gears sequentially by tipping the lever forward to shift down a ratio and shift up a gear by pulling the lever back.

F-TYPE's **8-inch colour Touch-screen** offers simple control of a number of the car's features, including Navigation, Infotainment and, where specified, the Dynamic-i display system. When connected, it can also interact with your smartphone through Jaguar InControl technology. Tailored apps offer a growing range of services: from reading news feeds to you, or selecting your favourite digital radio channels, to helping you discover the areas you're driving through with local information, events, detours and available parking spaces – they'll even help you book your hotel.

**Dual Mode Rotary Switches** are used as part of the controls for F-TYPE's advanced climate control system. Right and left dials control cockpit temperature on the respective sides of the car when dual zone climate control is specified. When pressed, the dials change mode to control the optional seat heating functions, with the screen at the centre of the dial changing to display the corresponding use.

INTERIOR SHOWN: F-TYPE S WITH PERFORMANCE SEATS IN CIRRUS PREMIUM LEATHER WITH JET UPPER FACIA AND STITCH





**START**

**ENGINE**

**STOP**

## SUPERCHARGED ENGINES

Power is delivered from a range of three advanced engines providing the perfect choice to suit individual needs – 3.0 V6 340PS in F-TYPE, 3.0 V6 380PS in F-TYPE S and 5.0 V8 550PS in F-TYPE R. Each features a Roots-type twin vortex supercharger mounted in the “V” of the engine to maintain the powerplants’ compact dimensions.

Jaguar is a leader in the field of **supercharged induction technology**. The advantages of supercharging are clear and compelling. It provides a linear delivery of performance, and instant access to high levels of torque at all engine speeds, minimising any delay between the driver’s demand for power and the engine’s response.

**F-TYPE’s Sports Exhaust** delivers a crisp note from start up, with the promise of performance building to a race-car inspired crescendo at high rpm and during overrun. An **Active Sports Exhaust** is standard on **F-TYPE** and **F-TYPE S**. The system features active bypass valves which open during performance driving to allow exhaust gases to exit more directly for a deep, dramatic sound. **F-TYPE R** includes a **Switchable Active Exhaust** allowing manual control of the system, for even greater driver involvement.

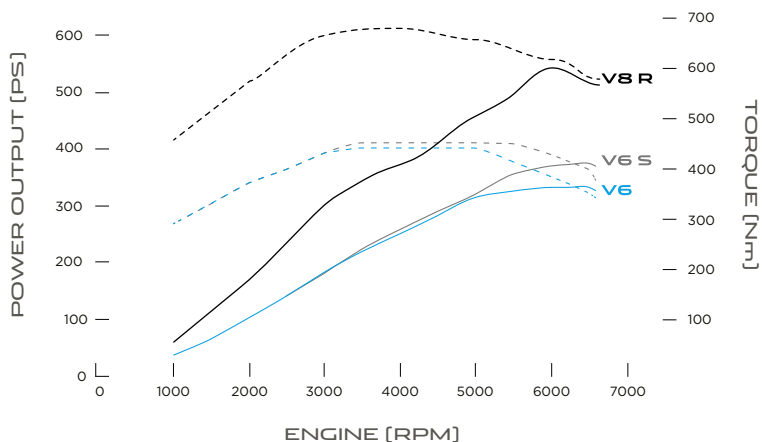

# V6

Jaguar's supercharged 3.0 V6 engines are powerful and refined. F-TYPE's 340PS engine provides formidable power, achieving a remarkable 450Nm of torque. F-TYPE S with its higher power output of 380PS, delivers an astoundingly potent performance. Both provide thrills and a rewarding driving experience. The compact supercharger's sophisticated boost control and secondary throttle valve ensure that torque curves rise steeply over a broad range of engine speeds. A water-cooled intercooler reduces the temperature of the intake air for greater power and efficiency, while an innovative system of counter-rotating front and rear balancer weights aids smoothness and refinement. They also feature a fast-reacting **Intelligent Stop/Start** system that can improve fuel economy by up to 5 percent.

## F-TYPE 3.0 LITRE V6 SUPERCHARGED PETROL

POWER 340PS  
TORQUE 450Nm

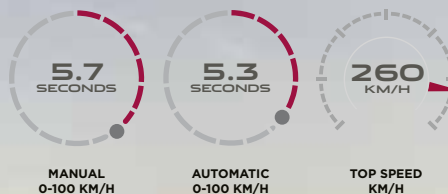

## F-TYPE S 3.0 LITRE V6 SUPERCHARGED PETROL

POWER 380PS  
TORQUE 460Nm

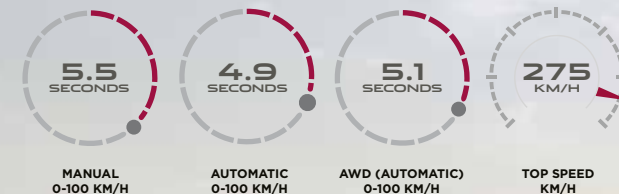

VEHICLE SHOWN: F-TYPE S AWD IN BLACK BERRY WITH OPTIONAL SPORT DESIGN PACK AND PANORAMIC ROOF

# V8

F-TYPE R's 5.0 V8 engine is supremely powerful and is the performance driver's choice. Its supercharger delivers up to 550PS and is capable of an astonishing 680Nm of torque. Acceleration is rapid and progressive, response is immediate and predictable. Advanced technologies deliver performance, refinement and efficiency. The lightweight die-cast aluminium block is supplemented by cross-bolted main bearing caps to increase rigidity. Valves are controlled by dual independent variable cam timing to optimise power at all engine speeds. Spray-guided direct injection delivers precisely measured quantities of fuel directly into the centre of the combustion chamber at pressures of up to 150bar for cleaner, more efficient combustion. An **Intelligent Stop/Start** system capable of improving fuel economy by 5 percent is also incorporated.

## F-TYPE R 5.0 LITRE V8 SUPERCHARGED PETROL

POWER 550PS

TORQUE 680Nm

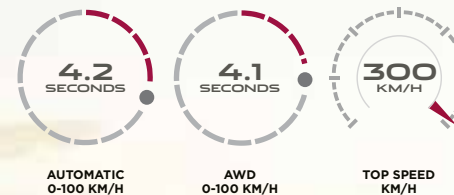



# THE RIGHT CAR, THE RIGHT GEAR

**Manual transmission** is available on **F-TYPE** and **F-TYPE S** offering a 6-speed manual gearbox. This lightweight unit is specifically designed for the performance requirements of sports car driving. The precision engineered short-throw gear lever is linked to a close ratio, 6-speed manual gearbox which enables the driver to keep the engine within its optimum rev range for longer, and delivers the purest of driving experiences.

**Automatic transmission** is available on every F-TYPE. Jaguar's Quickshift 8-speed automatic transmission is both lightning-fast and superbly refined, offering the benefits of a double clutch transmission and a conventional automatic without the limitations of either. Eight closely-spaced ratios keep the engine within its most effective rev range for longer, providing instantaneous response and outstanding driver feedback, while also optimising the engine for both economy and outright performance.

The transmission control system is intelligent and adaptive. It monitors the driving situation together with the demands the driver is making on the car, and responds to provide a truly dynamic experience. Adaptive software automatically modifies the gear shift strategy, ensuring the right gear is selected for every situation. The driver can also take full manual control of the transmission using either gear shift paddles mounted behind the steering wheel, or the joystick-style SportShift gear selector. Standard on **F-TYPE S** is **Dynamic Launch Mode**. This ensures maximum torque is applied through the gear changes delivering optimum acceleration from rest to 100 km/h.

**1,413 LITRES**

OF RECYCLED WATER PER MINUTE  
BLASTED AT EVERY CAR TO ENSURE F-TYPE  
IS MONSOON PROOF

**10,000,000 HOURS**

OF VIRTUAL TESTING, REDUCING OUR IMPACT ON THE  
ENVIRONMENT WITH SIGNIFICANT SAVINGS IN RESOURCE,  
WASTE, POWER AND FUEL

**792,000**

VIRTUAL VEHICLES CREATED BEFORE  
F-TYPE WAS PERFECTED

**12,000 MILES**

OF PUNISHING REAL WORLD EXTREME TRACK TESTING  
ON GERMANY'S INFAMOUS NÜRBURGRING RACE TRACK,  
EQUIVALENT TO DRIVING HALF WAY AROUND THE WORLD





## TESTING TAKEN TO NEW HEIGHTS

90°C

DIFFERENCE BETWEEN F-TYPE'S HOTTEST  
(+50°C) AND COLDEST (-40°C) EXTREME  
CLIMATE TESTING ENVIRONMENTS

300 TERABYTES

OF PERFORMANCE DATA GATHERED TO DEVELOP  
EVERY MILLIMETRE OF F-TYPE

F-TYPE first took to the road in the virtual world of Jaguar's Computer Aided Engineering (CAE) systems ensuring that all components underwent extensive development and testing before being committed to the physical testing process. Engineers produced a series of virtual prototypes to realistically simulate the behaviour of complex mechanical systems allowing them to analyse multiple variations until the optimum design was achieved. For example, using a technique first used in the aerospace industry, aerodynamic testing took place in a virtual wind tunnel with Computational Fluid Dynamics running on high speed supercomputers. During its virtual life, F-TYPE completed half a million analyses, requiring 10 million computer processor hours and creating 300TB of data. The CAE development process was one of the key contributing factors in delivering F-TYPE's exhilarating performance and responsiveness.

The real world testing to fine tune the set-up took place in specialist facilities and the harshest environments across the globe in temperatures ranging from -40°C to +50°C, and at altitudes of up to 4,000m. High-speed stability tests, for example, were conducted at Nardo in southern Italy. The Nordschleife circuit at the Nürburgring in Germany was the perfect location to prove out handling, braking, cooling and durability. Known as the "Green Hell", and featuring 20.8 kilometres of track with 73 turns, it is renowned as the most demanding circuit in the world and the ultimate test of both car and driver.





## A CAR THAT FEELS ALIVE

The essential ingredients in place, F-TYPE is ready to take on the world's most thrilling roads. You'll discover an intuitive and instinctive driving experience like no other. An experience that surpasses high performance and pin sharp handling to deliver pure entertainment. The most awe-inspiring and exhilarating twists and turns on the road belong to F-TYPE.



# ACTIVE AERODYNAMICS

Aerodynamic performance is the essence of F-TYPE's design and is seamlessly integrated into the body for low levels of lift and excellent stability at high speed. A front splitter beneath the grille and rear venturi manages airflow along the vehicle's underside with the sharply defined tail helping air to separate cleanly at lower speeds. A deployable rear spoiler rises at higher speeds to reduce lift by up to 120kg. Even the door handles retract when not required, with their flush design creating an uninterrupted airflow along the flanks.



## THE FASTEST CONNECTION BETWEEN DRIVER AND ROAD

F-TYPE's quick, responsive steering is designed to provide the most direct connection between the driver's hands on the wheel and the contact point of the tyres on the road. The car's steering rack delivers a precise reaction to driver input. The feeling of connection is also maximised by the use of aluminium alloy for the front subframe. This not only helps to reduce weight, but, in conjunction with F-TYPE's forged alloy suspension, also creates an immensely strong structure for the ultimate in precise feedback and control.

VEHICLES SHOWN: F-TYPE S IN CALDERA RED







## CHASSIS AND SUSPENSION

F-TYPE's aluminium body creates an immensely stable platform from which the all-round forged aluminium double wishbone suspension can control the car. With the damping set-up optimised for the best partnership between dynamics and refinement, it gives the perfect combination of control, agility and feedback.

On **F-TYPE S** and **F-TYPE R**, Adaptive Damping assesses body motion and pitch rates 100 times per second, and adjusts the settings for each damper accordingly. The system enhances control, handling and agility as well as the ability to rapidly detect and react to critical driving conditions and driver demands. It achieves this with a series of sensors that are placed around the car to monitor the body's vertical movement, pitch and roll rates. The steering wheel position is measured 500 times a second enabling the system to predict the body's roll rate. The stiffness of each individual damper is then adjusted to help maintain body control, stability and agility.

MONITORS ROAD-INDUCED BODY MOTION **100 TIMES** PER SECOND

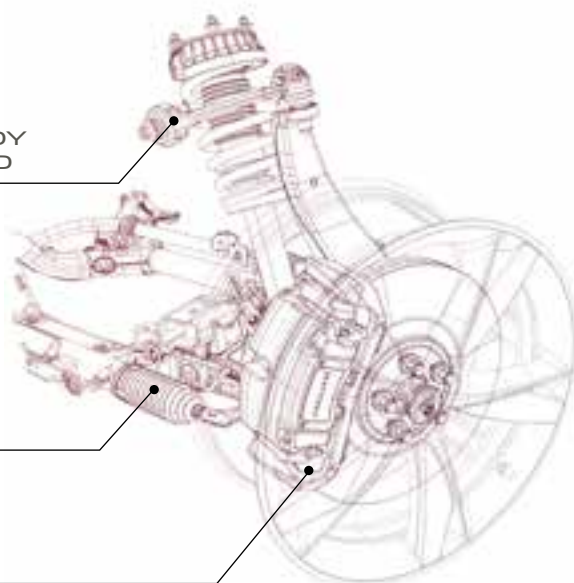

MONITORS STEERING WHEEL INPUT **500 TIMES** PER SECOND

**PREDICTS PITCH** FROM THROTTLE AND BRAKE INPUTS





A close-up, high-angle shot of a Jaguar wheel. The wheel features a multi-spoke design with a central hubcap that has a red and silver concentric circle pattern. A prominent yellow brake caliper is visible, with the text "JAGUAR" in large, bold, black letters and "CARBON CERAMIC" in smaller, black letters below it. The lighting is dramatic, highlighting the metallic surfaces of the wheel and the vibrant yellow of the caliper.

JAGUAR  
CARBON CERAMIC

# PERFORMANCE BRAKING SYSTEMS

A range of braking systems is available, each one engineered to deliver a confident, progressive feel and consistent high performance. The front calipers use aluminium to reduce the unsprung mass of the car, benefiting both handling and ride refinement. Each system features large, ventilated brake discs – up to 398mm in diameter on the Carbon Ceramic system. This large swept area improves braking force as well as providing greater capacity for the discs to absorb and dissipate the heat energy generated during braking.

Brake cooling is enhanced with additional suspension scoops and ducts developed with Jaguar's advanced Computational Fluid Dynamics systems. These channel cooling air directly to the brakes, reducing fade, and helping to sustain the brakes' performance during extended periods of dynamic driving.

Jaguar's exclusive Carbon Ceramic Braking system, with its striking yellow monobloc calipers, is optional on F-TYPE S and F-TYPE R. The most powerful braking system ever fitted to a Jaguar road car, it offers up to 21kg of weight saving, further reducing unsprung mass. With greater resistance to fade and wear it delivers high levels of sustained performance in the most demanding conditions. The system was track tested over hundreds of hours at race circuits including the Nürburgring, Rockingham in the UK and Fiorano in northern Italy; all recognised as taking an extraordinary toll on brake components. Temperatures on the Carbon Ceramic discs reached between 600°C and 900°C during fast lap driving.

F-TYPE  
JAGUAR  
PERFORMANCE



CALIPERS: SILVER

F-TYPE S  
JAGUAR HIGH  
PERFORMANCE



CALIPERS: BLACK (STANDARD)  
RED (OPTIONAL)

F-TYPE R  
JAGUAR SUPER  
PERFORMANCE



CALIPERS: RED

F-TYPE S AND F-TYPE R  
JAGUAR CARBON  
CERAMIC\*



CALIPERS: YELLOW

\*Carbon Ceramic brakes available as an option on F-TYPE S and F-TYPE R automatic models



BRAKE PRESSURE IS APPLIED TO INSIDE REAR WHEEL

GREATER AMOUNT OF POWER IS DISTRIBUTED TO OUTER REAR WHEEL

ADDITIONAL ROTATIONAL FORCE APPLIED AROUND VEHICLE'S AXIS

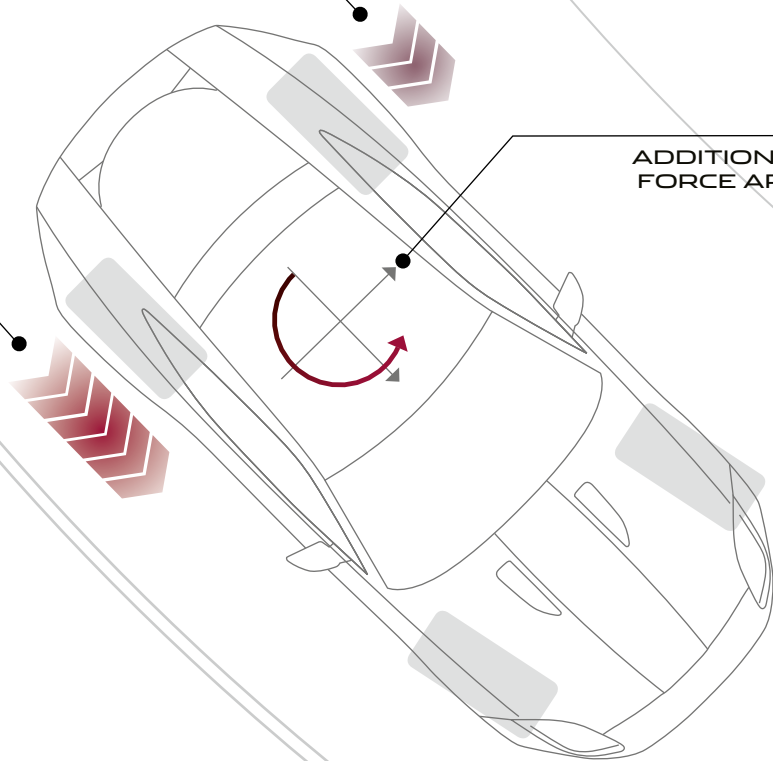

## TORQUE VECTORING BY BRAKING



INCREASED STEERING PERFORMANCE

INCREASED CORNERING CAPABILITY

Torque Vectoring technology enhances cornering and performance capabilities. A standard feature for **F-TYPE R**, it is also available for **F-TYPE S** and **F-TYPE**.

**Torque Vectoring by Braking** intelligently improves cornering control by applying finely metered braking forces individually to the inside wheels as necessary. It helps to turn F-TYPE into corners more precisely. Using F-TYPE's array of electronic sensors, the Torque Vectoring system can sense impending understeer. It then applies subtle and precise braking forces to the inner rear wheel, and feeds more torque to the outer rear wheel; finely adjusting the car's trajectory for optimal handling.

On **F-TYPE R**, the Torque Vectoring by Braking system works together with its **Electronic Active Differential** system, complementing each other to optimise traction and cornering ability as well as maximising steering feel and agility.

# ALL WHEEL DRIVE



INCREASED PERFORMANCE

ALL WEATHER CAPABILITY

All Wheel Drive truly makes **F-TYPE S AWD** and **F-TYPE R AWD** the most capable of sports cars. Available with Quickshift automatic transmissions, AWD works alongside Jaguar's **Intelligent Driveline Dynamics (IDD)** system to constantly analyse the car's behaviour and deploys appropriate power to optimise traction and stability. IDD uses F-TYPE's electronic sensors to detect impending understeer or oversteer, and swiftly redirects power to the appropriate axle, adjusting the car's trajectory through corners.

AWD also offers a distinct character differentiation between F-TYPE's driver-selected modes. When activated, Dynamic Mode delivers a more dynamic driving experience enhanced with the assurance of AWD stability, while the Rain/Ice/Snow Mode improves driving control in adverse conditions. The result is phenomenal cornering capabilities, providing outstanding levels of performance and control whatever the conditions.

UNDERSTEER

OVERSTEER

**POWER DIVERTED BETWEEN THE FRONT AND REAR WHEELS TO HELP MAINTAIN TRACTION AND AVOID UNDERSTEER AND OVERSTEER**

VEHICLE SHOWN: F-TYPE R AWD IN STORM GREY WITH OPTIONAL SPORT DESIGN PACK, CARBON FIBRE ROOF, STORM ALLOY WHEELS AND CARBON CERAMIC BRAKES









# ADAPTIVE DYNAMICS

**Adaptive Dynamics** instinctively modifies the car's response to road conditions and driver input, enhancing the driving experience. It analyses how the car is being driven by measuring acceleration, braking and cornering as well as road load and kick down activation. It then uses sophisticated adaptive software to ensure that the most appropriate gear shift strategy is automatically selected. For even more responsive performance, the selection of Sport Mode alters the gear shift programme to deliver shorter shifts and hold ratios at higher revs for longer.

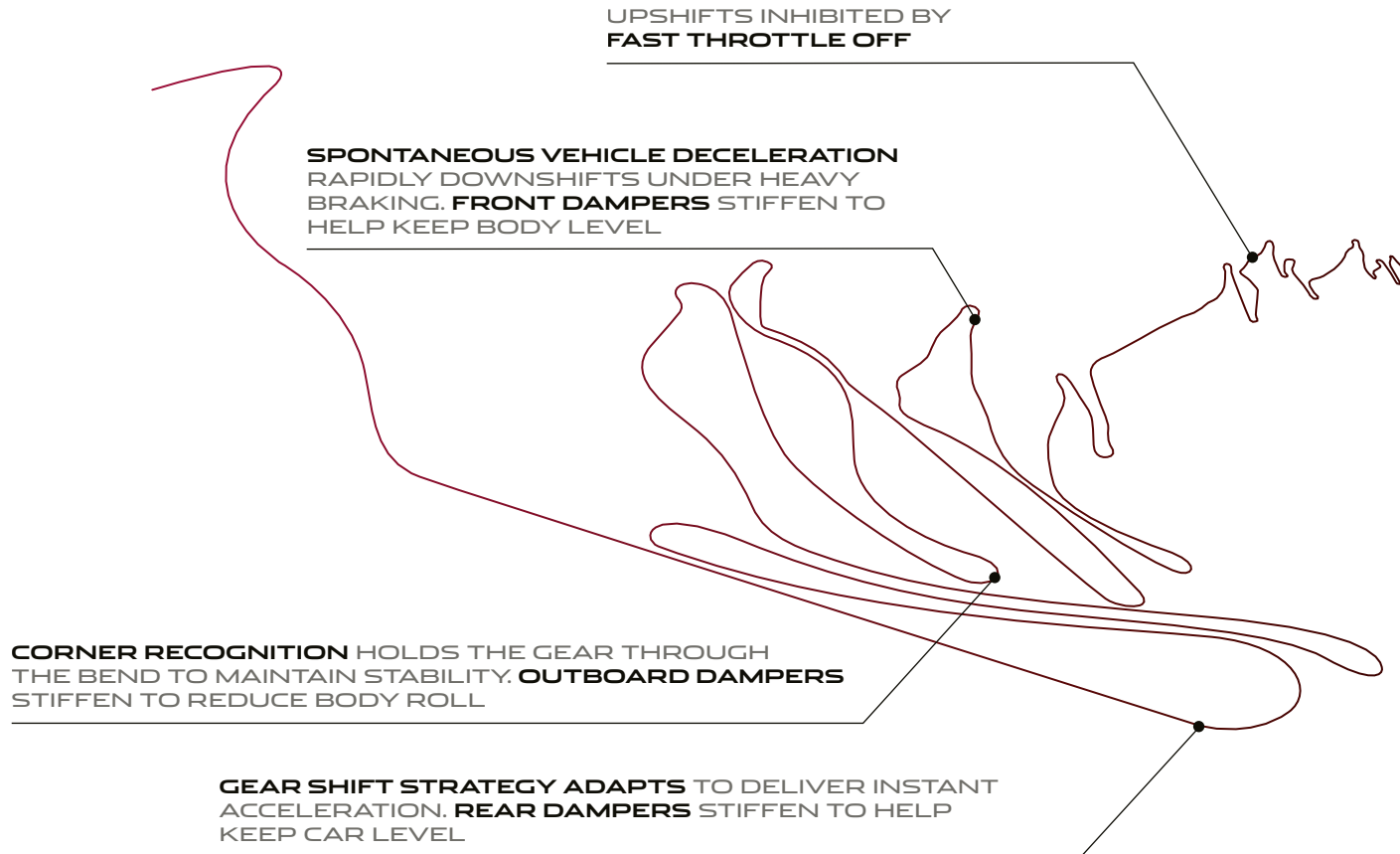



## DYNAMIC MODE

**>** SHARPENED THROTTLE RESPONSE | QUICKER GEAR SHIFTS

**Dynamic Mode** remaps the car's software to further emphasise its sporting character. It sharpens the throttle response, increases steering weighting and performs gear shifts more quickly and at higher engine speeds. Selecting Dynamic Mode also prevents automatic upshifts when the gearbox is used in manual mode.

The **Configurable Dynamics** system, utilised by **F-TYPE S** and **F-TYPE R**, allows the driver to define which characteristics are altered when Dynamic Mode is selected. This option also features the **Dynamic-i** display system, which can show performance indices such as G-Force meter and lap time, plus throttle, steering and brake inputs on the 8-inch Touch-screen.





## STAY CONNECTED



F-TYPE's all new InControl suite of products offers the latest technologies to connect you and your car to the outside world.

**Jaguar InControl Remote\*** includes SOS Emergency Call, which automatically brings the relevant services to your exact location in the event of a critical situation. It also provides Optimised Jaguar Assistance to transmit your location and vehicle diagnostic data to help minimise delays to your journey. The InControl Remote App enables you to monitor your F-TYPE through your smartphone to check fuel levels and whether, or not, it is locked. It also allows you to remotely pre-heat or pre-cool the car and lock/unlock your car.

**Jaguar InControl Secure\*** detects any unauthorised movement of your F-TYPE to alert you and liaise with the authorities to pinpoint the vehicle's whereabouts.

**Jaguar InControl Apps\*** connects your smartphone with the Touch-screen in your vehicle, meaning you can stay safely connected to your smartphone even whilst in the car. InControl Apps enables you to control compatible apps on your Touch-screen, ensuring the safe and convenient use of apps that have been optimised specifically for use within your vehicle.

Simply download Jaguar InControl Apps to your smartphone. You can then connect your smartphone via a dedicated USB port to display compatible Apps on the Touch-screen in the centre console.



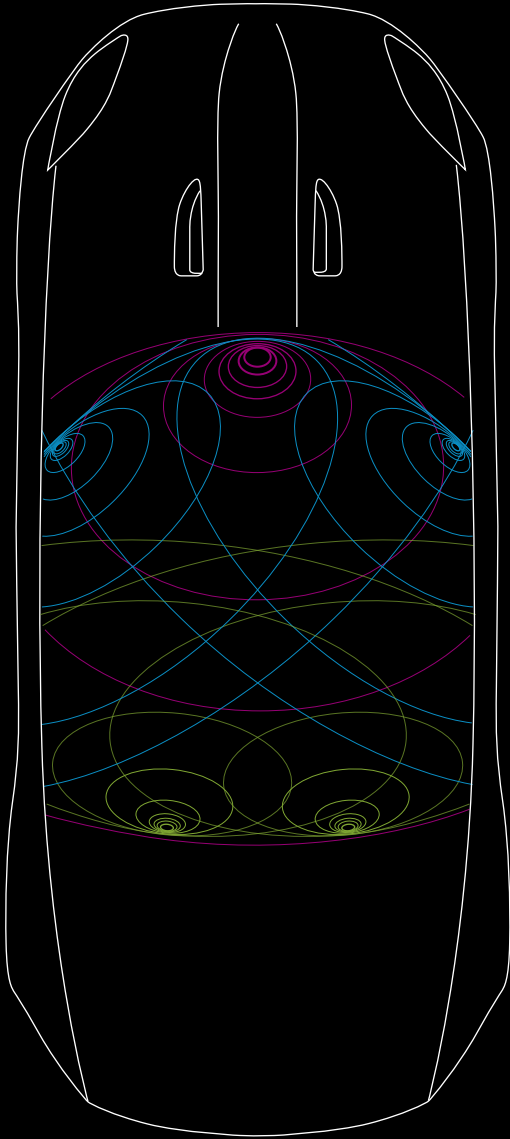

## PEAK PERFORMANCE



**JAGUAR**  
SOUND SYSTEM

**MERIDIAN** SOUND AND  
SURROUND SOUND SYSTEMS

Three superb audio systems bring the cockpit to life with incredible, rich sound. The **Jaguar Sound System** brings depth and power to in-car entertainment with 6 speakers, 180W and 8 channels.

Two higher specification systems were designed in conjunction with British audio experts Meridian specifically for F-TYPE. They feature advanced technology, such as Digital Signal Processing (DSP), to optimise every element of the system and use Meridian's advanced Cabin Correction algorithm to tailor the music experience to the precise acoustics of the vehicle's interior. The systems feature Dynamic Volume Control which compensates for changes in sound levels within the car to ensure that audio quality is always consistent. The **Meridian Sound System** offers superb audio reproduction through 10 speakers – including 2 sub woofers, **380W** and 12 channels.

The ultimate **Meridian Surround Sound System** features 12 speakers and **770W**. This advanced system uses Meridian Trifield technology to deliver an authentic and consistent music experience within the cabin.



-  Holographic Centre Image
-  Door Waves: Tweeter, Midrange and Bass
-  Surround Sound Waves

Diagram representative of Meridian 770W Surround Sound System.



**MERIDIAN**



**180** 

WATTS

**6** 

SPEAKERS

**8** 

AMPLIFIER CHANNELS

**JAGUAR SOUND SYSTEM**  
180W, 6 Speakers, 8 channel amplifier.



**380** 

WATTS

**10** 

SPEAKERS

**12** 

AMPLIFIER CHANNELS

**MERIDIAN SOUND SYSTEM\***  
380W, 10 Speakers, 12 channel class D  
DSP amplifier. Dynamic volume control.



**770** 

WATTS

**12** 

SPEAKERS

**16** 

AMPLIFIER CHANNELS

**MERIDIAN SURROUND SOUND SYSTEM**  
770W, 12 Speakers, 16 channel class D DSP amplifier,  
Audyssey MultEQ Audio Equalisation, Dynamic volume  
control, 7.1 Surround Sound, Meridian Trifield technology.

\*Trifield' and the 'three fields' device are trademarks of Trifield Productions Ltd.  
\*Please consult your dealer for availability

## ASSISTANCE AND REASSURANCE

Sophisticated driver assistance systems are available for F-TYPE providing reassurance, information and control, so you can focus on the pleasure of the drive. F-TYPE's optional **Reverse Traffic Detection** system is there to assist you when reversing out of a parking space. Sensors in the rear of the car help detect vehicles approaching from either direction, and display a warning on the Touch-screen. **Closing Vehicle Sensing** uses sophisticated sensors to help warn if faster moving vehicles are approaching from behind at a distance of up to approximately 60m while **Blind Spot Monitoring** is designed to provide an extra alert should the system detect a vehicle entering a pre-defined blind spot.

**Bi-Function HID Xenon Headlamps** provide an intense white light for both main and dipped beam in a single unit. The optional **Adaptive Front Lighting** system measures the speed of the car and angle of the steering wheel, swivelling the lamps by up to 14 degrees out, and up to 7 degrees in, for improved visibility during cornering. The optional **Intelligent High Beam** system automatically switches between low and high beam when necessary, using a sensor mounted at the front of the rear view mirror. The rear lamps feature LED technology with light guides that not only create a distinctive design, but also have the ability to illuminate to full brightness more quickly than conventional bulbs, giving a following driver more time to react. Every F-TYPE also features a complement of advanced active and passive safety systems, including **Emergency Brake Assist (EBA)**, **Electronic Brake-Force Distribution (EBD)**, driver and passenger front airbags, seat-mounted airbags, seat belt pre-tensioners and an industry-leading **Pedestrian Contact Sensing System**.



ADAPTIVE FRONT LIGHTING  
WITH CORNERING LAMPS



BLIND SPOT MONITOR  
WITH CLOSING  
VEHICLE SENSING



CRUISE CONTROL  
AND AUTOMATIC  
SPEED LIMITER



EMERGENCY BRAKE  
ASSIST

VEHICLE SHOWN: F-TYPE R AWD IN GLACIER WHITE WITH OPTIONAL SPORT DESIGN PACK AND BLACK PACK





## THE LUXURY OF SPACE

 **407 LITRES** | **OPTIONAL POWERED TAILGATE**

F-TYPE Coupé's generous capacity of up to 407 litres is large enough to accommodate a full set of luggage or up to two sets of golf clubs. For ease of access and added convenience, the tailgate can be opened or closed at the touch of a button with the optional powered function.



**KBS 257**

R IS INTENSITY. IT PROVIDES MORE. AND DELIVERS THE ULTIMATE  
EXPRESSION OF F-TYPE: THE MOST POWERFUL, THE MOST DYNAMICALLY  
CAPABLE, THE MOST THRILLING. F-TYPE R IS THE SPORTS CAR AT ITS MOST  
HONED, SENSUOUS AND EXCITING.







# PERFORMANCE

> 5.0 V8 550PS | 680NM

Coupé or Convertible, F-TYPE R is the definitive sports car. Powered by Jaguar's incredible 5.0 V8 550PS supercharged engine with 680Nm of torque for sheer unadulterated performance that is 100 percent exploitable - 0-100 km/h in 4.2 seconds (0-60mph in 4.1 seconds), best-in-class power output and power-to-weight. **F-TYPE R** takes full advantage of the extremely rigid bodyshell. Its stiffness provides the definitive platform for suspension enhancements that can apply available traction and fully harness the immense power on hand.

When **F-TYPE R** is combined with optional **All Wheel Drive (AWD)**, the synthesis of formidable power, heart-stopping performance and astonishing handling capabilities makes this Jaguar's ultimate performance vehicle.

VEHICLE SHOWN RIGHT: F-TYPE R AWD IN GLACIER WHITE WITH OPTIONAL SPORT DESIGN PACK AND BLACK PACK  
VEHICLE SHOWN ON PREVIOUS PAGE: F-TYPE R IN POLARIS WHITE WITH OPTIONAL PANORAMIC ROOF AND BLACK PACK





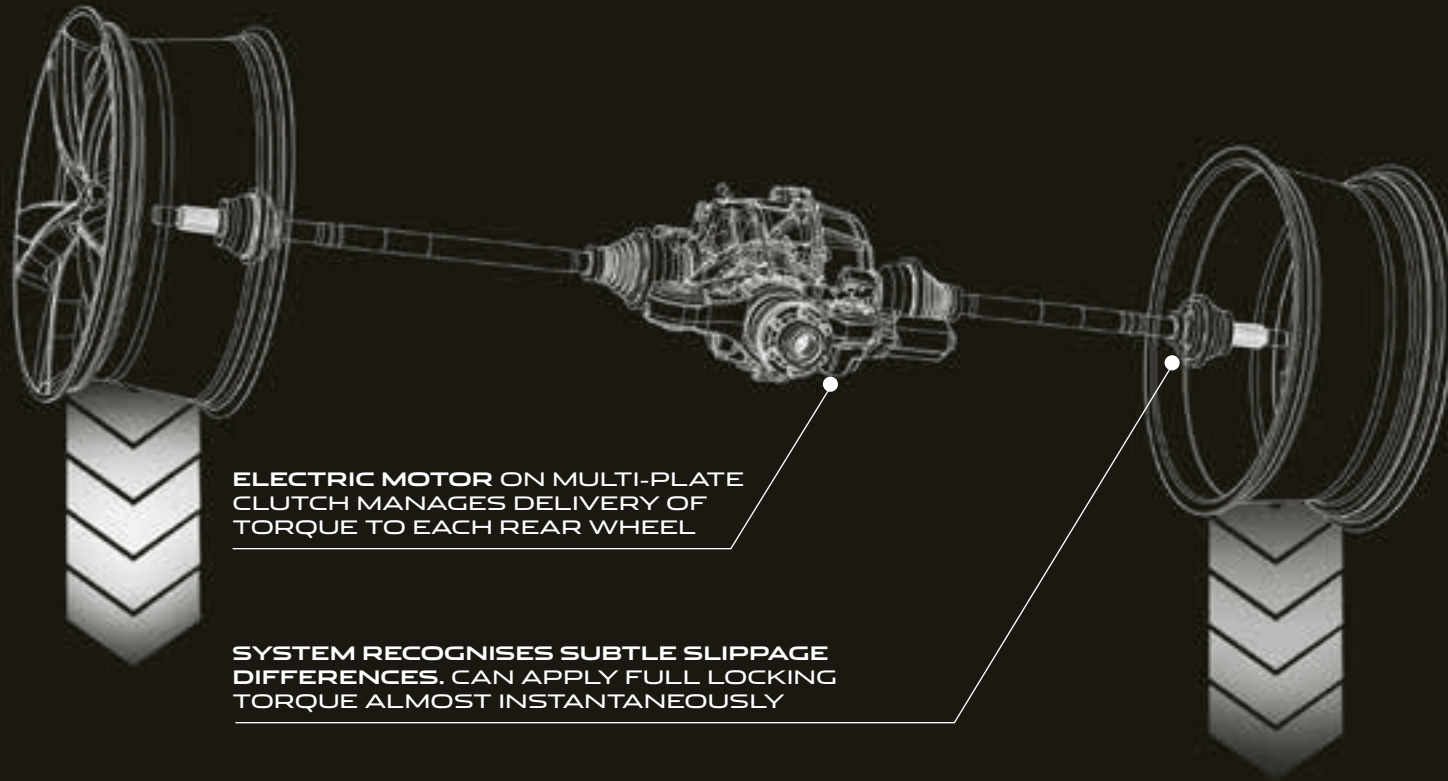

**ELECTRIC MOTOR ON MULTI-PLATE CLUTCH MANAGES DELIVERY OF TORQUE TO EACH REAR WHEEL**

**SYSTEM RECOGNISES SUBTLE SLIPPAGE DIFFERENCES. CAN APPLY FULL LOCKING TORQUE ALMOST INSTANTANEOUSLY**

## ELECTRONIC ACTIVE DIFFERENTIAL

Exclusive to **F-TYPE R**, the **Electronic Active Differential** forms part of the Torque Vectoring technology which helps provide outstanding agility and control. Working in conjunction with the stability, traction and ABS systems, the Electronic Active Differential uses an electric motor, acting on a multi-plate clutch, to manage the delivery of torque to each of the rear wheels. Full electronic control of the rear differential lock enables the system to apply full locking torque almost instantaneously. The Electronic Active Differential allows for very fine control of the power delivery to limit wheelspin, maximise traction and offer even greater levels of control.

On AWD models, the **Intelligent Driveline Dynamics (IDD)** system works seamlessly with the **F-TYPE R**'s Electronic Active Differential, helping to increase traction and stability allowing the car to take full advantage of the engine's towering performance.





## R INSIDE

> PREMIUM  
LEATHER INTERIOR

| 'R' EMBOSSED  
HEADRESTS

**F-TYPE R**'s interior dials up the intensity of the 1+1 experience to represent the pinnacle of Jaguar craftsmanship and dynamics. The R theme gives the car a unique personality and includes Dark Technical Weave Aluminium on the centre console finishers. There is Premium leather with twin needle stitching and, for more lateral support during more enthusiastic driving, body-hugging Performance Seats with embossed R logo on the headrest. The car also features an R 3-spoke leather steering wheel with Silver paddles.

INTERIOR SHOWN: F-TYPE R WITH PERFORMANCE SEATS IN JET AND IVORY DUOTONE



## YOUR F-TYPE

F-TYPE is the ultimate sports car and it's ultimately yours. Offering a wide range of personalisation options, the choices you make create the car you'll love. Select the body and roof colours that suit you and choose the perfect wheels to complement them.

You can make your F-TYPE unique by tailoring your personal interior styling, specifying your ideal seats and choosing the textures and colour combinations, as well as taking your pick from the range of three superb audio systems including two from British audio experts Meridian. With Jaguar's exceptional collection of style packs, accessories and options your F-TYPE becomes truly bespoke - your ideal sports car - your perfect F-TYPE.





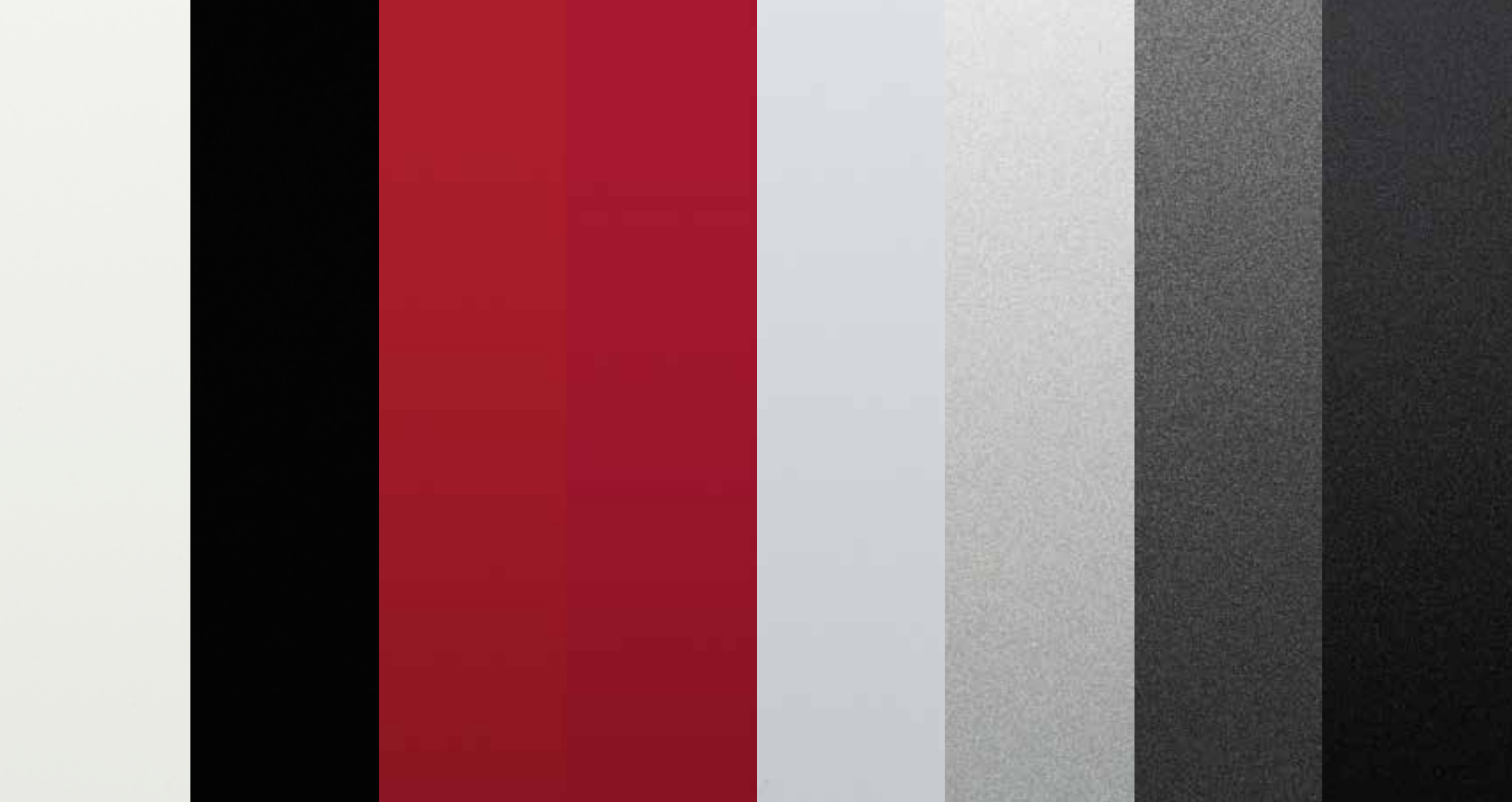

EXTERIOR COLOURS

SOLID

Polaris White

Ebony Black

Salsa Red\*

Caldera Red\*

METALLIC

Glacier White

Rhodium Silver

Ammonite

Stratus Grey\*

\*Available until May 2015 †Available from June 2015





Ultimate Black

Dark Sapphire

Firesand

Italian Racing Red

British Racing Green

**PREMIUM**  
Storm Grey†

Black Berry

# ALLOY WHEELS

An opportunity to add even more sportiness and individuality.

## > 18" ALLOY WHEEL



18" VELA  
SILVER  
Standard on F-TYPE

## > 19" ALLOY WHEELS



19" PROPELLER  
SILVER  
Standard on F-TYPE S  
Option on F-TYPE



19" VOLUTION  
SILVER  
Standard on F-TYPE S AWD



19" VOLUTION  
TECHNICAL GREY AND  
DIAMOND TURNED  
Option on F-TYPE S AWD



19" CENTRIFUGE  
SILVER  
Option on F-TYPE  
and F-TYPE S



19" CENTRIFUGE  
GLOSS BLACK  
Option on F-TYPE  
and F-TYPE S



19" ORBIT  
SILVER  
Option on F-TYPE  
and F-TYPE S



19" ORBIT  
GLOSS BLACK AND  
DIAMOND TURNED  
Option on F-TYPE  
and F-TYPE S

**>** 20" ALLOY WHEELS



20" TURBINE  
SILVER  
Option on all F-TYPE models



20" CYCLONE  
SILVER  
Option on all F-TYPE models



20" CYCLONE  
GLOSS BLACK  
Option on all F-TYPE models



20" TORNADO  
SILVER  
Option on all F-TYPE models



20" TORNADO  
GLOSS BLACK  
Option on all F-TYPE models



20" BLADE  
FORGED ALLOY TECHNICAL GREY  
AND CARBON FIBRE  
Option on all F-TYPE models



20" ROTOR  
FORGED ALLOY  
GLOSS BLACK  
AND CARBON FIBRE  
Option on all F-TYPE models



20" GYRODYNE  
SILVER  
Standard on F-TYPE R



20" GYRODYNE  
DARK GREY  
AND DIAMOND TURNED  
Option on F-TYPE R



20" STORM  
SATIN ANTHRACITE GREY  
Option as part of Carbon  
Ceramic Brake Pack 1



20" STORM  
FORGED ALLOY  
SATIN BLACK AND POLISHED  
Option as part of Carbon  
Ceramic Brake Pack 2

# ROOFS

F-TYPE offers a range of different roofs to suit your own personal style. Each delivering their own distinctive characteristics, they provide a powerful expression of individual flair both inside the cabin and to the outside world.



## ALUMINIUM ROOF

For the pure Coupé look, F-TYPE's aluminium roof is as strong and lightweight as the rest of the vehicle. It provides the ideal complement in colour, style and line to the powerful F-TYPE profile. The aluminium roof expresses F-TYPE in its clearest sports car form.



## PANORAMIC GLASS ROOF

Introducing even more natural light and airiness to the interior, a full width panoramic glass roof is optional on F-TYPE Coupé models. For increased seclusion, should it be required, the roof features a manually sliding 'black-out' blind, which can screen the occupants from up to 99 percent of the incoming light.



## CARBON FIBRE ROOF\*

With carbon fibre outer and inner panels bonded together to create a strong yet light roof structure, F-TYPE Coupé's optional carbon fibre roof is 20 percent lighter than the standard aluminium roof. It features carbon fibre weave visible through a deep, high-grade lacquered finish.



## FABRIC ROOF

F-TYPE Convertible's lightweight fabric roof is acoustically enhanced with composite fabric to reduce noise and features a flush fitting heated glass rear window. The roof can be raised or lowered in just 12 seconds and operated fully automatically at speeds of up to 50 km/h.

\*Please consult your dealer for availability

VEHICLES SHOWN: F-TYPE R IN POLARIS WHITE WITH OPTIONAL BLACK PACK



CONVERTIBLE ROOFS

Jet

Grey

Red

Beige

# SEATS

**F-TYPE** and **F-TYPE S** feature a **Sports Seat** with leather and Suedecloth facings as standard. Both models can be specified with the optional **Performance Seat** in Premium leather which offers enhanced lateral support during rapid cornering. **F-TYPE R** features the Performance Seat as standard with the R badge embossed on the headrest. Both the Sports and Performance seats feature 4-way electric and 2-way manual adjustment, or 14-way electric adjustment and memory function as an option. They can also be specified with a heated function. For the finishing touch, it is also possible to choose between Jet, Red or Camel seatbelts.



**SPORTS SEAT**



**PERFORMANCE SEAT**



**R PERFORMANCE SEAT**



 SEAT TRIM

Jet leather  
(Also available in Suedecloth,  
and Premium leather)

Cirrus leather  
(Also available in Suedecloth,  
and Premium leather)

Red  
Premium leather

Brogue  
Premium leather

Camel  
Premium leather

Ivory  
Premium leather

# MODELS

## STANDARD FEATURES

6-speed close ratio manual transmission\* (F-TYPE and F-TYPE S)  
• Quickshift 8-speed automatic transmission with SportShift selector and steering wheel mounted one touch paddles (F-TYPE S AWD, F-TYPE R and F-TYPE R AWD) • Dynamic mode • Dynamic Stability Control (DSC) with Trac DSC mode • Intelligent Stop/Start system • Electric Parking Brake (EPB) – drive-away release • Deployable rear spoiler • Bi-function HID Xenon headlamps with washers and LED signature lights • LED tail lamps • Jaguar Smart Key System with Keyless start • Instrument cluster – twin dials with 5-inch colour TFT display • 8-inch colour Touch-screen display • Navigation system • Jaguar Sound System • USB, Auxiliary socket and iPod connectivity • Pedestrian Contact Sensing System

## DIMENSIONS

Overall length: 4470mm  
Overall width: 2042mm  
Overall height: 1311mm (Coupé) 1308mm (Convertible)



## F-TYPE COUPÉ AND CONVERTIBLE

**ENGINE** 3.0 Litre V6 340 Supercharged

### ACCELERATION

0-100 km/h 5.3 seconds (0-60 mph 5.1 seconds) – auto  
0-100 km/h 5.7 seconds (0-60 mph 5.5 seconds) – manual

**TOP SPEED** 260 km/h (161 mph)

**EMISSIONS** CO<sub>2</sub> 199 g/km (auto) 234 g/km (manual)

Jaguar Performance Braking System with Silver calipers  
Sports suspension  
Sports Exhaust with centre mounted twin exhaust pipes  
18" Vela alloy wheels  
Sports seats with leather and Suedecloth facings  
3-spoke leather steering wheel with Black gear shift paddles (automatic only)  
Light Hex Aluminium console finisher  
Available with Quickshift 8-speed automatic or 6-speed manual transmission\*



## F-TYPE S COUPÉ AND CONVERTIBLE

**ENGINE** 3.0 Litre V6 380 Supercharged

### ACCELERATION

0-100 km/h 4.9 seconds (0-60 mph 4.8 seconds) – auto  
0-100 km/h 5.5 seconds (0-60 mph 5.3 seconds) – manual

**TOP SPEED** 275 km/h (171 mph)

**EMISSIONS** CO<sub>2</sub> 203 g/km (auto) 234 g/km (manual)

Jaguar High Performance Braking System with Black calipers  
Sports suspension with Adaptive Dynamics  
Active Sports Exhaust with centre mounted twin exhaust pipes  
19" Propeller alloy wheels  
Configurable Dynamics System  
Limited Slip Differential  
Sports seats with leather and Suedecloth facings  
3-spoke leather steering wheel with Ignis gear shift paddles (automatic only)  
Dark Hex Aluminium console finisher with 'S' graphic  
Configurable Ambient Interior Lighting with selectable palette  
Available with Quickshift 8-speed automatic or 6-speed manual transmission\*

## DESIGNER'S INSPIRATION

F-TYPE's designers are inspired by the craftsmanship and attention to detail of some of the world's most exclusive brands. They bring together the finest materials to create interior combinations that are uniquely Jaguar.

\*Please consult your dealer for availability  
Figures shown are for automatic transmission  
Official EU figures for comparison purposes only. Real world figures may differ







## F-TYPE S AWD COUPÉ AND CONVERTIBLE

**ENGINE** 3.0 Litre V6 380 Supercharged  
**ACCELERATION** 0-100 km/h 5.1 seconds  
(0-60 mph 4.9 seconds)  
**TOP SPEED** 275 km/h (171 mph)  
**EMISSIONS** CO<sub>2</sub> 211 g/km

### ADDITIONAL AWD KEY FEATURES

All Wheel Drive System  
Intelligent Driveline Dynamics  
'AWD' bonnet with body coloured vents  
19" Evolution Silver alloy wheels  
Available with Quickshift 8-speed automatic transmission



## F-TYPE R COUPÉ AND CONVERTIBLE

**ENGINE** 5.0 Litre V8 550 Supercharged  
**ACCELERATION** 0-100 km/h 4.2 seconds  
(0-60 mph 4.0 seconds)  
**TOP SPEED** 300 km/h (186 mph)  
**EMISSIONS** CO<sub>2</sub> 255 g/km

Jaguar Super Performance Braking System with Red calipers  
Sports suspension with Adaptive Dynamics  
Switchable Active Sports Exhaust with quad exhaust pipes  
20" Gyrodyne Silver alloy wheels  
Configurable Dynamics System  
Electronic Active Differential with Torque Vectoring by Braking  
Performance seats with Premium leather facings  
and 'R' embossing  
3-spoke leather steering wheel with Silver gear shift paddles  
Dark Technical Weave Aluminium console finisher  
with 'R' graphic  
Configurable Ambient Interior Lighting with selectable palette  
Available with Quickshift 8-speed automatic transmission



## F-TYPE R AWD COUPÉ AND CONVERTIBLE

**ENGINE** 5.0 Litre V8 550 Supercharged  
**ACCELERATION** 0-100 km/h 4.1 seconds  
(0-60 mph 3.9 seconds)  
**TOP SPEED** 300 km/h (186 mph)  
**EMISSIONS** CO<sub>2</sub> 269 g/km

### ADDITIONAL AWD KEY FEATURES

All Wheel Drive System  
Intelligent Driveline Dynamics  
'AWD' bonnet with body coloured vents  
Available with Quickshift 8-speed automatic transmission



# F-TYPE

The essential F-TYPE: powerful, responsive, pure Jaguar sports car. Available as both Coupé or Convertible with Quickshift 8-speed automatic or 6-speed manual transmission.

## OPTIONS AND ACCESSORIES\*



Accessory Rear Mounted Ski Carrier



Accessory Chrome Mirror Covers

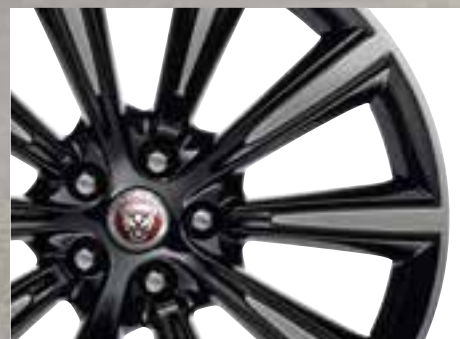

Optional 19" Orbit Gloss Black and Diamond Turned alloy wheels



Optional Panoramic Glass Roof

\*Available at extra cost

VEHICLE SHOWN: F-TYPE COUPÉ IN RHODIUM SILVER WITH 18" VELA WHEELS





STANDARD - SPORTS SEATS WITH LEATHER AND SUEDECLOTH FACINGS

	SEAT WITH STITCH	UPPER FACIA WITH STITCH	CONSOLE FINISHER	HEADLINING	CARPETS	SEATBELTS
TP01						
	Jet with Jet	Jet with Jet	Light, Dark or Black Hex <sup>1</sup>	Jet or Stone	Jet or Cirrus	Jet or Red
TP04						
	Cirrus with Cirrus	Jet with Jet	Light, Dark or Black Hex <sup>1</sup>	Jet or Stone	Jet or Cirrus	Jet

Interior Shown: Jet leather and Suedecloth Sports seats with Jet upper facia and stitch, Jet Morzine headlining with Light Hex Aluminium console finisher and Jet carpets.

# F-TYPE

## INTERIOR COLOUR COMBINATIONS

### OPTIONAL - SPORTS SEATS WITH LEATHER FACINGS

	SEAT WITH STITCH	UPPER FACIA WITH STITCH	CONSOLE FINISHER	HEADLINING	CARPETS	SEATBELTS
TP01+B40W						
	Jet with Jet	Jet with Jet	Light, Dark or Black Hex <sup>1</sup>	Jet or Stone	Jet or Cirrus	Jet or Red
TP04+B40W						
	Cirrus with Cirrus	Jet with Jet	Light, Dark or Black Hex <sup>1</sup>	Jet or Stone	Jet or Cirrus	Jet

### OPTIONAL - SPORTS SEATS IN PREMIUM LEATHER AND PREMIUM LEATHER INTERIOR















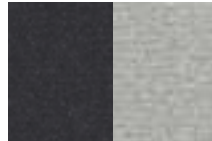



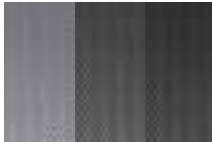

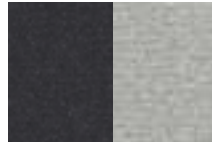















	SEAT WITH STITCH	UPPER FACIA WITH STITCH	CONSOLE FINISHER	HEADLINING*	CARPETS	SEATBELTS
TP01+Z84M						
	Jet with Jet	Jet with Jet	Light, Dark or Black Hex <sup>1</sup>	Jet or Stone	Jet or Cirrus	Jet or Red
TP04+Z84M						
	Cirrus with Cirrus	Jet with Jet	Light, Dark or Black Hex <sup>1</sup>	Jet or Stone	Jet or Cirrus	Jet

<sup>1</sup>Jet Morzine standard, Stone Morzine and Jet Suedecloth optional  
<sup>2</sup>Black Hex Aluminium console finisher only available with Interior Black Pack

IMAGE SHOWN TOP RIGHT: ACCESSORY UNION JACK SILL TREAD PLATES  
 CENTRE: ACCESSORY SUEDECLOTH STEERING WHEEL  
 BOTTOM: ACCESSORY 5-PIECE LUGGAGE SET



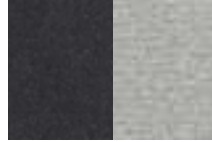





OPTIONAL - PERFORMANCE SEATS IN PREMIUM LEATHER AND PREMIUM LEATHER INTERIOR



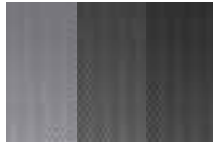

	SEAT WITH STITCH	UPPER FACIA WITH STITCH	CONSOLE FINISHER	HEADLINING*	CARPETS	SEATBELTS
TP01+BS5C+ Z84M	 Jet with Jet	 Jet with Jet	 Light, Dark or Black Hex¹	 Jet or Stone	 Jet or Cirrus	 Jet or Red
TP05	 Jet with Red	 Jet with Jet	 Light, Dark or Black Hex¹	 Jet, Stone or Red†	 Jet or Cirrus	 Jet or Red
TP06	 Jet with Camel	 Jet with Jet	 Light, Dark or Black Hex¹	 Jet or Stone	 Jet or Cirrus	 Jet or Camel
TP07	 Jet with Firesand	 Jet with Jet	 Light, Dark or Black Hex¹	 Jet or Stone	 Jet or Cirrus	 Jet
TP11	 Bogue with Ivory	 Jet with Jet	 Light, Dark or Black Hex¹	 Jet, Stone or Ivory	 Jet or Cirrus	 Jet
TP12	 Red with Jet	 Jet with Jet	 Light, Dark or Black Hex¹	 Jet, Stone or Red†	 Jet or Cirrus	 Jet or Red

	SEAT WITH STITCH	UPPER FACIA WITH STITCH	CONSOLE FINISHER	HEADLINING*	CARPETS	SEATBELTS
TP13						
	Camel with Jet	Jet with Jet	Light, Dark or Black Hex <sup>1</sup>	Jet or Stone	Jet or Cirrus	Jet or Camel
TP27						
	Cirrus with Jet	Jet with Jet	Light, Dark or Black Hex <sup>1</sup>	Jet or Stone	Jet or Cirrus	Jet
TP28						
	Ivory with Jet	Jet with Jet	Light, Dark or Black Hex <sup>1</sup>	Jet, Stone or Ivory	Jet or Cirrus	Jet

OPTIONAL - PERFORMANCE SEATS IN PREMIUM LEATHER AND SUEDECLOTH AND PREMIUM LEATHER INTERIOR

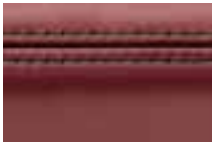
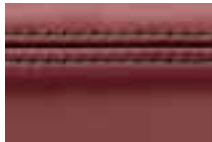
TP22						
	Jet with Cirrus	Jet with Cirrus	Light, Dark or Black Hex <sup>1</sup>	Jet	Jet	Jet

OPTIONAL - PERFORMANCE SEATS IN RED PREMIUM LEATHER AND RED PREMIUM LEATHER INTERIOR WITH JET TWIN NEEDLE CONTRAST STITCHING

TP23						
	Red with Jet	Red with Jet	Light, Dark or Black Hex <sup>1</sup>	Jet or Red <sup>†</sup>	Jet	Jet or Red

\*Jet Morzine standard, Stone Morzine and Jet Suedecloth optional

<sup>†</sup>Red headlining available on Convertible only

<sup>1</sup>Black Hex Aluminium console finisher only available with Interior Black Pack

# F-TYPE S

Packed with technology for true sporting exhilaration that awakens your senses. Available as both Coupé or Convertible with Quickshift 8-speed automatic or 6-speed manual transmission.

## OPTIONS AND ACCESSORIES\*



Optional Jaguar Super Performance Braking System



Accessory 20" Rotor Silver Composite Weave alloy wheels



Accessory Wind Deflector also featuring optional Body Coloured Roll Over Protection Bars

\*Available at extra cost

VEHICLE SHOWN: F-TYPE S CONVERTIBLE IN CALDERA RED WITH 19" PROPELLER WHEELS





# F-TYPE S AWD

All the character of F-TYPE S with the additional capability of AWD.  
Available as both Coupé or Convertible with Quickshift 8-speed automatic transmission.

## OPTIONS AND ACCESSORIES\*



Accessory Carbon Fibre Mirror Covers



Accessory All Weather Car Cover



Optional 19" Volution Technical Grey and Diamond Turned alloy wheels



Optional Exterior Sport Design Pack with Fixed Rear Spoiler†

\*Available at extra cost †Available from May 2015

VEHICLE SHOWN: F-TYPE S AWD COUPÉ IN BLACK BERRY WITH 19" VOLUTION SILVER WHEELS





STANDARD - SPORTS SEATS WITH LEATHER AND SUEDECLOTH FACINGS

	SEAT WITH STITCH	UPPER FACIA WITH STITCH	CONSOLE FINISHER	HEADLINING	CARPETS	SEATBELTS
TP01						
	Jet with Jet	Jet with Jet	Light, Dark or Black Hex <sup>1</sup>	Jet or Stone	Jet or Cirrus	Jet or Red
TP04						
	Cirrus with Cirrus	Jet with Jet	Light, Dark or Black Hex <sup>1</sup>	Jet or Stone	Jet or Cirrus	Jet

Interior Shown: Cirrus leather and Suedecloth Sports seats with Jet upper facia and stitch, Jet Morzine headlining with Light Hex Aluminium console finisher and Jet carpets.

# F-TYPE S AND F-TYPE S AWD

## INTERIOR COLOUR COMBINATIONS

### OPTIONAL - SPORTS SEATS WITH LEATHER FACINGS

	SEAT WITH STITCH	UPPER FACIA WITH STITCH	CONSOLE FINISHER	HEADLINING	CARPETS	SEATBELTS
TP01+B40W						
	Jet with Jet	Jet with Jet	Light, Dark or Black Hex <sup>1</sup>	Jet or Stone	Jet or Cirrus	Jet or Red
TP04+B40W						
	Cirrus with Cirrus	Jet with Jet	Light, Dark or Black Hex <sup>1</sup>	Jet or Stone	Jet or Cirrus	Jet

### OPTIONAL - SPORTS SEATS IN PREMIUM LEATHER AND PREMIUM LEATHER INTERIOR















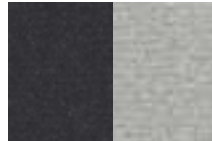



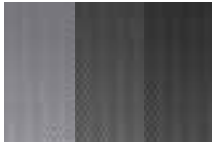

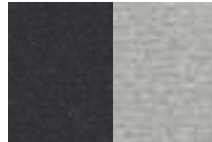















	SEAT WITH STITCH	UPPER FACIA WITH STITCH	CONSOLE FINISHER	HEADLINING*	CARPETS	SEATBELTS
TP01+Z84M						
	Jet with Jet	Jet with Jet	Light, Dark or Black Hex <sup>1</sup>	Jet or Stone	Jet or Cirrus	Jet or Red
TP04+Z84M						
	Cirrus with Cirrus	Jet with Jet	Light, Dark or Black Hex <sup>1</sup>	Jet or Stone	Jet or Cirrus	Jet

\*Jet Morzine standard, Stone Morzine and Jet Suedecloth optional  
<sup>1</sup>Black Hex Aluminium console finisher only available with Interior Black Pack

IMAGE SHOWN TOP RIGHT: OPTIONAL PERFORMANCE SEATS  
 CENTRE: OPTIONAL FLAT-BOTTOMED LEATHER SPORTS STEERING WHEEL  
 BOTTOM: ACCESSORY ALUMINIUM GEARSHIFT PADDLES



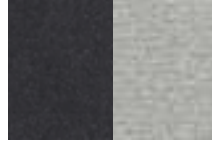





OPTIONAL - PERFORMANCE SEATS IN PREMIUM LEATHER AND PREMIUM LEATHER INTERIOR



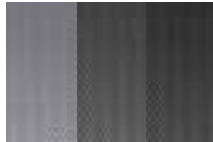

	SEAT WITH STITCH	UPPER FACIA WITH STITCH	CONSOLE FINISHER	HEADLINING*	CARPETS	SEATBELTS
TP01+BS5C+ Z84M	 Jet with Jet	 Jet with Jet	 Light, Dark or Black Hex¹	 Jet or Stone	 Jet or Cirrus	 Jet or Red
TP05	 Jet with Red	 Jet with Jet	 Light, Dark or Black Hex¹	 Jet, Stone or Red†	 Jet or Cirrus	 Jet or Red
TP06	 Jet with Camel	 Jet with Jet	 Light, Dark or Black Hex¹	 Jet or Stone	 Jet or Cirrus	 Jet or Camel
TP07	 Jet with Firesand	 Jet with Jet	 Light, Dark or Black Hex¹	 Jet or Stone	 Jet or Cirrus	 Jet
TP11	 Bogue with Ivory	 Jet with Jet	 Light, Dark or Black Hex¹	 Jet, Stone or Ivory	 Jet or Cirrus	 Jet
TP12	 Red with Jet	 Jet with Jet	 Light, Dark or Black Hex¹	 Jet, Stone or Red†	 Jet or Cirrus	 Jet or Red

	SEAT WITH STITCH	UPPER FACIA WITH STITCH	CONSOLE FINISHER	HEADLINING*	CARPETS	SEATBELTS
TP13						
	Camel with Jet	Jet with Jet	Light, Dark or Black Hex <sup>1</sup>	Jet or Stone	Jet or Cirrus	Jet or Camel
TP27						
	Cirrus with Jet	Jet with Jet	Light, Dark or Black Hex <sup>1</sup>	Jet or Stone	Jet or Cirrus	Jet
TP28						
	Ivory with Jet	Jet with Jet	Light, Dark or Black Hex <sup>1</sup>	Jet, Stone or Ivory	Jet or Cirrus	Jet

OPTIONAL - PERFORMANCE SEATS IN PREMIUM LEATHER AND SUEDECLOTH AND PREMIUM LEATHER INTERIOR

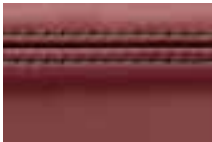
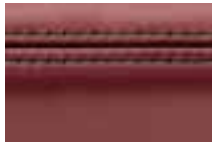
TP22						
	Jet with Cirrus	Jet with Cirrus	Light, Dark or Black Hex <sup>1</sup>	Jet	Jet	Jet

OPTIONAL - PERFORMANCE SEATS IN RED PREMIUM LEATHER AND RED PREMIUM LEATHER INTERIOR WITH JET TWIN NEEDLE CONTRAST STITCHING

TP23						
	Red with Jet	Red with Jet	Light, Dark or Black Hex <sup>1</sup>	Jet or Red <sup>†</sup>	Jet	Jet or Red

\*Jet Morzine standard, Stone Morzine and Jet Suedecloth optional

<sup>†</sup>Red headlining available on Convertible only

<sup>1</sup>Black Hex Aluminium console finisher only available with Interior Black Pack

# F-TYPE R

Agility, control and the power to set your heart racing, the definitive Jaguar sports car. Available as both Coupé or Convertible with Quickshift 8-speed automatic transmission.

## OPTIONS AND ACCESSORIES\*



Optional Carbon Ceramic Brake Pack



Accessory Carbon Fibre Bonnet Louvres



Accessory Carbon Fibre Roll Over Protection Bars



Optional 20" Gyrodyne Dark Grey and Diamond Turned alloy wheels

\*Available at extra cost

VEHICLE SHOWN: F-TYPE R CONVERTIBLE IN GLACIER WHITE WITH 20" GYRODYNE SILVER WHEELS





# F-TYPE R AWD

All the character of F-TYPE R with the added performance edge of AWD.  
Available as both Coupé or Convertible with Quickshift 8-speed automatic transmission.

## OPTIONS AND ACCESSORIES\*



Accessory Carbon Fibre Bonnet Louvres



Accessory Carbon Fibre Engine Cover



Optional Carbon Fibre Roof\*\*



Optional 20" Storm Forged Satin Black and Polished alloy wheels

\*Available at extra cost

\*\*Please consult your dealer for availability

VEHICLE SHOWN: F-TYPE R AWD IN STORM GREY WITH 20" GYRODYNE SILVER WHEELS















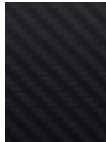



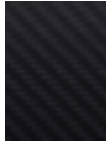





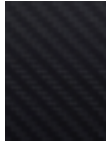

Interior Shown: Jet Premium leather Performance Seats with Jet upper facia and Ivory stitch, Jet Morzine headlining with Dark Technical Weave console finisher and Jet carpets.

# F-TYPE R AND F-TYPE R AWD

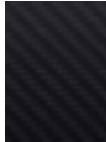
## INTERIOR COLOUR COMBINATIONS

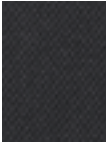
STANDARD - PERFORMANCE SEATS WITH PREMIUM LEATHER AND PREMIUM LEATHER INTERIOR WITH TWIN NEEDLE STITCHING

	SEAT WITH STITCH	UPPER FACIA WITH STITCH	CONSOLE FINISHER	HEADLINING	CARPETS	SEATBELTS
TP01						
	Jet with Jet	Jet with Jet	Dark Technical Weave or Light Hex	Jet or Stone	Jet	Jet
TP17						
	Jet with Ivory	Jet with Ivory	Dark Technical Weave or Light Hex	Jet, Stone or Ivory*	Jet	Jet
TP24						
	Jet with Red	Jet with Red	Dark Technical Weave or Light Hex	Jet, Stone or Red*	Jet	Jet or Red
TP18						
	Jet with Firesand	Jet with Firesand	Dark Technical Weave or Light Hex	Jet or Stone	Jet	Jet

\*Ivory leather headlining not available with Panoramic glass roof  
 \*Red headlining available on Convertible only

IMAGE SHOWN TOP RIGHT: ACCESSORY CARBON FIBRE CENTRE CONSOLE  
 CENTRE: OPTIONAL HEATED STEERING WHEEL  
 BOTTOM: OPTIONAL DUAL ZONE CLIMATE CONTROL





STANDARD - PERFORMANCE SEATS WITH PREMIUM LEATHER AND PREMIUM LEATHER INTERIOR WITH TWIN NEEDLE STITCHING

	DUOTONE SEAT WITH STITCH	UPPER FACIA WITH STITCH	CONSOLE FINISHER	HEADLINING	CARPETS	SEATBELTS
TP21						
	Jet and Camel	Jet with Camel	Dark Technical Weave or Light Hex	Jet or Stone	Jet	Jet or Camel
TP20						
	Jet and Ivory	Jet with Ivory	Dark Technical Weave or Light Hex	Jet, Stone or Ivory*	Jet	Jet

Interior Shown: Red Premium leather Performance Seats with Red upper facia and Jet stitch, Jet leather headlining with Dark Technical Weave console finisher and Jet carpets.

# F-TYPE R AND F-TYPE R AWD

## INTERIOR COLOUR COMBINATIONS

STANDARD - PERFORMANCE SEATS WITH PREMIUM LEATHER AND PREMIUM LEATHER INTERIOR WITH TWIN NEEDLE STITCHING



OPTIONAL - PERFORMANCE SEATS IN PREMIUM LEATHER AND SUEDECLOTH AND PREMIUM LEATHER INTERIOR



OPTIONAL - PERFORMANCE SEATS IN RED PREMIUM LEATHER AND RED PREMIUM LEATHER INTERIOR WITH JET TWIN NEEDLE CONTRAST STITCHING



\*Ivory leather headlining not available with Panoramic glass roof  
<sup>†</sup>Red headlining available on Convertible only  
<sup>‡</sup>Jet Morzine standard, Jet Suedecloth optional

IMAGE SHOWN TOP RIGHT: OPTIONAL BRIGHT STAINLESS STEEL PEDALS  
 CENTRE: OPTIONAL POWERED TAILGATE  
 BOTTOM: OPTIONAL MERIDIAN SOUND SYSTEM - 380W









## EXPERIENCE F-TYPE. EXPERIENCE JAGUAR

There's no better way to get to know F-TYPE and Jaguar than taking a drive. The Jaguar Experience offers a range of unique opportunities to really find out what we mean when we say our cars feel alive. Our track experiences allow you to push yourself, F-TYPE and other cars from the incredible Jaguar range to the limit. Other driving experiences include challenge holidays such as Alive on Ice 2015 on the frozen lakes of Finland and the luxury Tour D'Elegance in South Africa. The Jaguar Experience also offers the opportunity to see a Jaguar brought to life during a tour of one of our UK manufacturing facilities at Castle Bromwich, Birmingham. Find out more by visiting [jaguarexperience.com](http://jaguarexperience.com)

To test drive F-TYPE, please contact your local Jaguar dealer directly.







#### IMPORTANT NOTICE

Jaguar Land Rover Limited is constantly seeking ways to improve the specification, design and production of its vehicles and alterations take place continually. While every effort is made to produce up-to-date literature, this brochure should not be regarded as an infallible guide to current specifications, nor does it constitute an offer for the sale of any particular vehicle. Distributors and dealers are not agents of Jaguar Land Rover Limited by any express or implied undertaking or representation. Comparisons are based on manufacturer's own data and testing.

#### ENVIRONMENTAL INNOVATION AT JAGUAR

Jaguar is proud to continue the company's tradition with its approach to Environmental Innovation. From the choice of lightweight materials and lean production methods to the efficiency of its engines and designs, Jaguar is committed to operating as a more sustainable business and reducing its overall environmental impact.

Jaguar's flagship XJ model was the first in the company to achieve ISO14040, the international standard for vehicle 'life cycle assessment'. This certification measures the environmental impact of XJ from component material sourcing and manufacturing process, through driving 200,000 km. But that's not all. Every new Jaguar is designed to be 85% Recyclable/Reusable and 95% Recoverable at the end of the vehicle's life.

The XE, XJ, F-TYPE and XK's innovative use of lightweight aluminium, which incorporates up to 50% closed-loop recycled material from the manufacturing process of the body structures, provides considerable performance benefits. This includes improved fuel consumption and less CO<sub>2</sub> emissions during the use phase of the Life Cycle due to lighter structures. Our on-going target is to ensure scrap aluminium reclaimed from our stamping process is to be segregated and recycled through a closed loop system and re-melted into the same grade quality sheet, therefore reducing CO<sub>2</sub> emissions during the production phase of the Life Cycle. Jaguar is committed to reducing dependency on fossil fuels, using fewer resources and creating less waste as part of our approach to sustainability excellence.

The company plan includes 25% reduction targets in operating and tailpipe CO<sub>2</sub> emissions, waste to landfill, logistics efficiencies (15%) and water consumption (10%), all based on per vehicle built since 2007. In addition the manufacturing assembly CO<sub>2</sub> emissions of each Jaguar built in the UK since 2009 is 100% offset. For each tonne of CO<sub>2</sub> emitted in the assembly process, Jaguar invests in projects that reduce an equivalent tonne of CO<sub>2</sub> elsewhere. Taking into account the company's global sales growth and increased investment in more efficient operating facilities, we are proud to have delivered and in some cases exceeded our Environmental Innovation targets as planned for 2012. And we are on track to meet our 25% reduction in joint European fleet average tailpipe CO<sub>2</sub> emissions by 2015.

Looking forward, we have developed our 2020 vision for sustainable business growth that focuses on continued improvements in tailpipe CO<sub>2</sub> emissions, operational carbon neutrality and zero waste. To date the company has offset over 6 million tonnes of CO<sub>2</sub>, provided over 4,000 direct jobs in 60 emissions reductions projects in 17 countries and improved the lives of over 1 million people in our global cook stoves emissions reduction programme.

But it doesn't stop there. Our manufacturing facilities have been certified to ISO14001 since 1998 and we are credited to Platinum Plus level in the UK's Business in the Community Corporate Responsibility Index.

Castrol® EDGE™ Professional is exclusively recommended by Jaguar.

#### VEHICLE SHOWN: F-TYPE R IN STORM GREY WITH OPTIONAL STORM ALLOY WHEELS AND CARBON CERAMIC BRAKES

'Trifield™' and the 'three fields' device are trademarks of Trifield Productions Ltd.  
iPod, iPod touch and iPad are trademarks of Apple Inc., registered in the U.S. and other countries.



Go behind the scenes at Jaguar.  
Download the Jaguar Magazine app  
- just search "Jaguar Magazine"  
in the App Store™



Jaguar Land Rover Limited,  
Registered Office: Abbey Road, Whitley,  
Coventry, CV3 4LF, United Kingdom  
Registered in England Number: 1672070  
jaguar.com



