



CHEVROLET CORVETTE STINGRAY



—

**A SPORTS
CAR DYNASTY
CONTINUES.**

The eighth-generation Corvette continues to impress the most seasoned automobile enthusiasts around the world.

Available in coupe or convertible, the new Corvette is everything mid-engine advocate and Corvette patron saint Zora Arkus-Duntov could have imagined.

The new Stingray is a Corvette for a new age and will no doubt entice future generations of Corvette enthusiasts who seek a driving experience like no other.



BENEFITS OF MID-ENGINE



—
BEAUTY

UNDER

GLASS.

Your first impression is that beautiful engine behind the cockpit, visible on coupe models. Why is it located there? First, this puts the weight of the engine over the rear-driving wheels to enhance traction. With the engine behind the cockpit, there's more forward visibility. And with the seats positioned closer to the front wheels, the driver and passenger are at the car's center of gravity.

The result is the kind of reflexes you'd expect from a well-honed sports car. Stingray proves that life is indeed a beautiful ride.

DESIGN



SWEEPING PROPORTIONS

WITH A BOLD,
WIDE STANCE.

Mid-engine architecture dictated a different shape for the eighth-generation Corvette. Designers made a polite nod to its proud heritage. Function played a huge role, with large front intakes and sculpted side intakes that help the engine breathe and stay cool. With the cockpit moved significantly forward, the side profile reveals a short hood with a long, graceful rear deck. The rear fascia features two functional air exits flanked by twin taillamps and twin exhaust outlets on each side, leaving no doubt about what you're driving.



—
EXPERIENCE

THE ROAD LIKE

NEVER BEFORE.

The eighth-generation Corvette cockpit is well-suited to enthusiast driving. Your driving position is some 40 cm forward compared to the previous generation. The low forward cowl makes it easy to see, while a racing-style steering wheel with paddle shifters keeps the view pure and also provides extra

knee room. Your rear sight lines are equally as impressive, thanks to the Rear Camera Mirror. Console controls include a push-button toggle switch gear selector and a leather-wrapped Driver Mode Selector. Finally, a flowing buttress is topped with easy-to-reach climate controls.

—
THE COUPE.

THE CONVERTIBLE.



The Stingray coupe features a lightweight, easily removable roof panel that stows conveniently in the rear trunk. Choose from a standard body-color roof panel or available transparent or carbon-fiber versions. The coupe also has a clear glass cover to display the engine.

The Stingray convertible features a production retractable hardtop that automatically folds neatly over the engine compartment in 17 seconds and can be operated at speeds up to 31 mph.

The convertible hardtop retains the coupe's aerodynamic form and produces a similar drag coefficient with the top up. In the lowered position, the top does not intrude on trunk space. Track enthusiasts will be pleased to know that the newest convertible with the top up meets the same standards as the coupe.

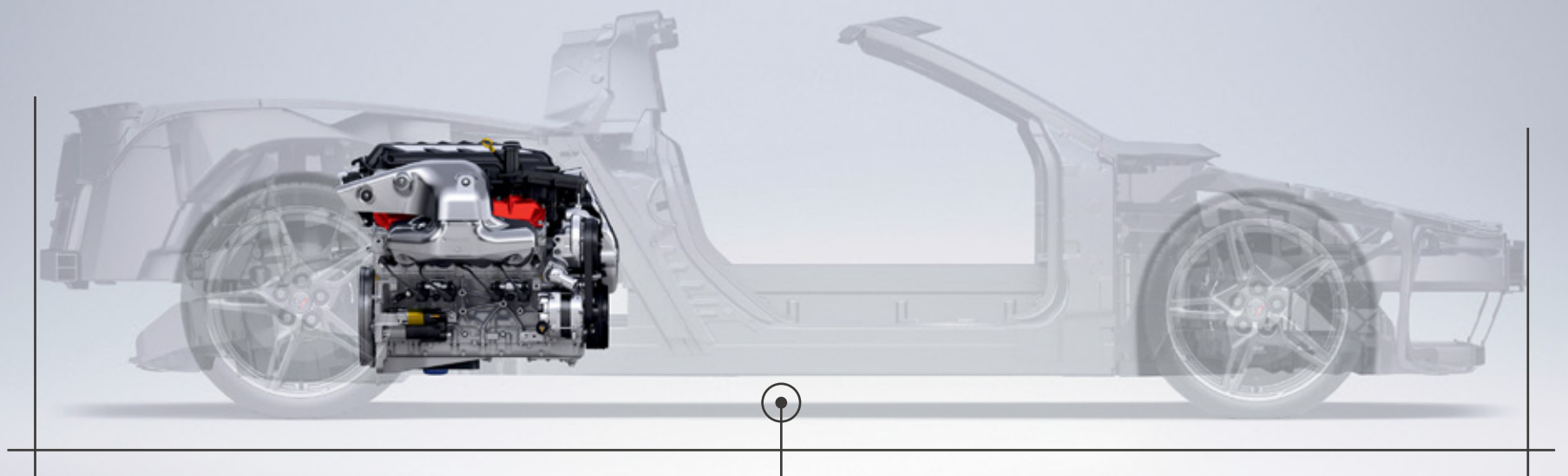

40/60 FRONT-TO-REAR
WEIGHT DISTRIBUTION

—

**A 40/60 WEIGHT
DISTRIBUTION,
FOR PERFORMANCE
PERFECTION.**

For most of automotive history, engineers have sought a 50/50 weight distribution, especially for front-engine cars with rear-driving wheels. But Zora Arkus-Duntov declared a 40/60 front-to-rear weight ratio as ideal when he was developing the first Chevrolet mid-engine concept car — CERVI (Chevrolet Experimental Research Vehicle).

The newest generation of Stingray uses the same 40/60 front-to-rear weight ratio. Equally important, however, is the extraordinary rigidity of the structure itself, thanks to its architecture and materials. The Stingray structure is 30% to 50% stiffer than some well-respected competitors.

The secret is a closed center tunnel backbone conjoined by twin rails top and bottom. Many of the aluminum pieces are made with high-pressure die castings for extraordinary density. Others are made out of cast, forged or extruded aluminum. There is even a carbon-fiber rear bumper beam.

This rigid structure not only allows Stingray to change direction in heroic ways, but also quickens acceleration times.

S U S P E N S I O N





—

**COILED AND READY
TO DEVOUR ANY
CORNER.**



Quick reflexes were mandatory. The eighth-generation Corvette features a modified SLA (short/long arm) suspension geometry as well as coil springs on all four corners of the car. This configuration keeps spring rates and damping low for comfort while enabling track high-g cornering capability.

The available Magnetic Selective Ride Control™ integrates with the Driver Mode Selector to adjust ride stiffness in real time using magnetized ferrous particles in the shock fluid.

For even greater capability, the European Stingray comes standard with the Z51 Performance Package that includes Michelin Pilot Sport 4S summer-only tires¹.

¹ Do not use summer-only tires in winter conditions, as it would adversely affect vehicle safety, performance and durability. Use only GM-approved tire and wheel combinations. Unapproved combinations may change the vehicle's performance characteristics. For important tire and wheel information, please contact your Chevrolet Partner. Low-profile tires wear faster, and wheel and tire damage may occur on rough or damaged roads from surfaces or kerbs, debris or obstacles. This damage is not covered by the GM New Vehicle Limited Warranty.



ENGINE

HEART AND SOUL.

Powering Stingray is a 6.2L LT2 aluminum small block V8 engine¹. Now in fifth-generation form, it is more compact, yet more powerful than ever with 482 horsepower and 613 Nm of torque at 4500 rpm. The intake system is a lowrestriction design and incorporates 210 mm runners and an 87 mm throttle body. The performance header exhaust manifolds are also low-restriction and feature a stylized four-into-one design. What makes the European version of the Corvette Stingray unique is the standard Z51 Performance Package, which is good for a 0 to 62 mph sprint of 3.5 seconds. Paired with a particular filter and standard performance exhaust muffler, the European Corvette Stingray delivers thrilling sound while fulfilling stringent European emission regulations.

A standard dry-sump oil system is integrated into the block and allows the engine to be positioned for a lower center of gravity. Three scavenging pumps capture circulating oil to ensure pressurized distribution even in the highest-g situations on the track.

¹ Chevrolet Corvette Stingray 6.2L V8 - Fuel consumption combined (mpg): 23.3. CO₂ emissions combined (g/km): 277. Energy efficiency category: M.

PERFORMANCE



**IT'S ALL ABOUT THE
SEAMLESS ADMINISTRATION
OF POWER.**

The new Corvette is equipped with advanced powertrain technologies that let you get the most out of almost any driving situation. One of those is the standard Driver Mode Selector. It allows the driver to select preferences when it comes to shift points, steering effort, engine sound and braking feel. Bad weather or freezing conditions can also affect choices. Six driving modes are available, including four standard presets –

Tour, Weather, Sport and Track – plus two flexible modes. These include My Mode, which allows you to create your own combination of presets for everyday use, and Z Mode, which lets you choose from a larger menu of high-performance settings for the engine, transmission and steering, especially for a particular road or track – all by pressing the silver Z button on the steering wheel.

The control of a manual. The smoothness of an automatic. And it shifts faster than any human can, helping create the fastest-accelerating production Stingray ever. The 8-speed dual-clutch transmission is effectively two manual gearboxes that have clutches actuated by computers on a concentric shaft so there is no torque loss.

There's a shaft for even gears 2-4-6-8-R and another for odd gears 1-3-5-7. The shifting schedule aligns to your chosen Driver Mode Selector position. As you shift via the paddles, you can simultaneously engage one shaft while you're disengaging another, giving you the ultimate feeling of control.



Z MODE STEERING WHEEL BUTTON

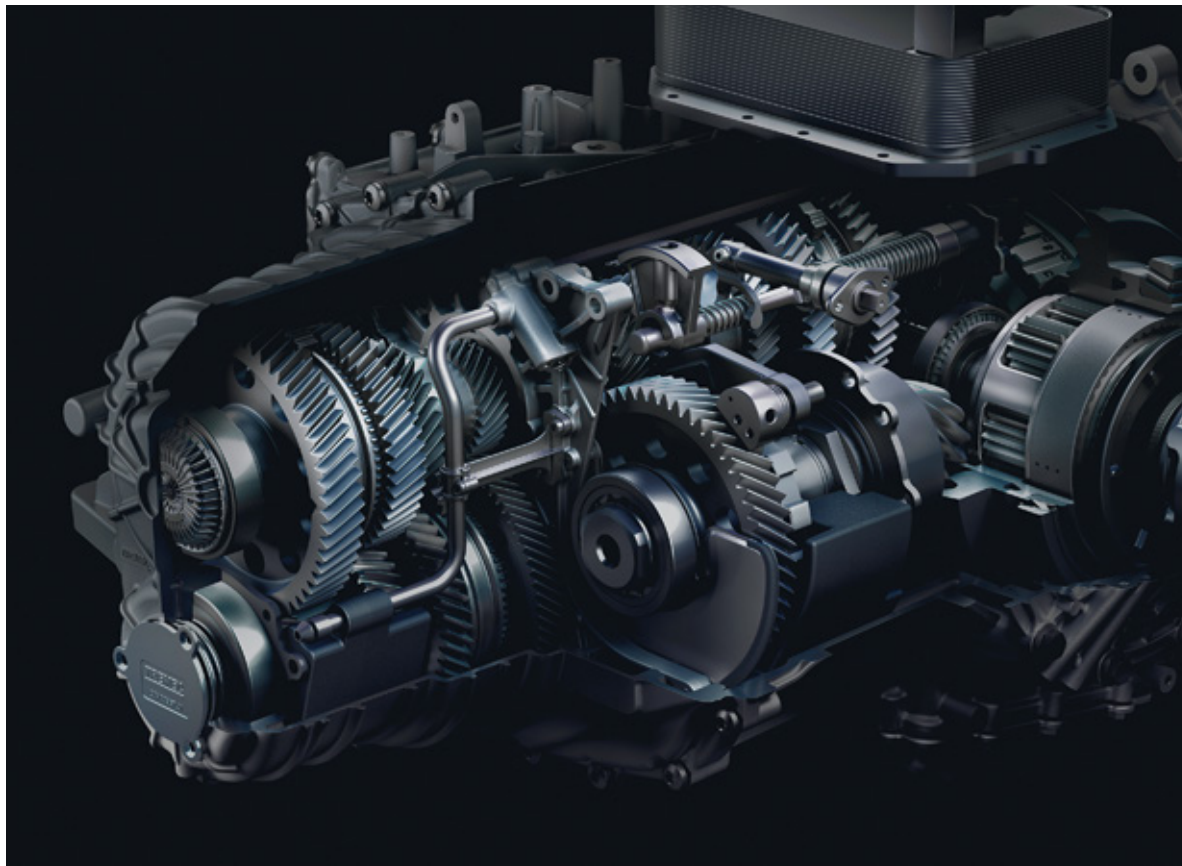

8-SPEED DUAL-CLUTCH TRANSMISSION

PERFORMANCE

Z51 PERFORMANCE PACKAGE.



THE PINNACLE OF PERFORMANCE.

The architecture, structure, suspension, calibrations and software of Stingray are all ready to deliver a driving experience beyond your imagination. To reach the pinnacle, the standard Z51 Performance Package provides a group of performance enhancements, including:

- Performance brakes with larger brake rotors and performance brake pads
- Performance suspension
- Performance exhaust
- Performance final drive ratio
- Electronic Limited-Slip Differential
- Rear spoiler and front splitter
- Michelin® Pilot® Sport 4S summer-only tires¹
- Heavy-duty cooling system
- Optional with a Magnetic Selective Ride Control system that includes Performance Traction Management



¹ Do not use summer-only tires in winter conditions, as it would adversely affect vehicle safety, performance and durability. Use only GM-approved tire and wheel combinations. Unapproved combinations may change the vehicle's performance characteristics. For important tire and wheel information, please contact your Chevrolet Partner. Low-profile tires wear faster, and wheel and tire damage may occur on rough or damaged roads from surfaces or kerbs, debris or obstacles. This damage is not covered by the GM New Vehicle Limited Warranty.

TECHNOLOGY



CHOOSE THE INFORMATION THAT SUITS YOUR SITUATION.

Corvette engineers recognize that you have different information needs in different driving situations. A 12" diagonal customizable gauge cluster dominates the controls with graphics that change completely depending on your selected driving mode. You can view the wide cluster display neatly framed by the racing-style steering wheel. The display itself has two panels on the left side of the tachometer and four panels with track display that you can populate with specific information or gauges using the Options menu. An 8" diagonal color touch-screen is conveniently positioned just to the right of the central cluster.

A button and pull toggle gear selector helps simplify the console area. The Driver Mode Selector features a leather-accented palm rest, while climate controls are located atop the buttress separating driver and passenger.



GEAR AND DRIVER MODE SELECTORS



CLIMATE AND SEAT CONTROLS
ATOP COCKPIT BUTTRESS

TECHNOLOGY



8" DIAGONAL COLOR TOUCH-SCREEN



BOSE PERFORMANCE SERIES 14-SPEAKER SYSTEM

TECHNOLOGY

UNTETHERED.

High performance takes on many dimensions in the Stingray. Among them is a 14-speaker Bose Performance Series, the most powerful sound system ever in a Stingray. Plus Apple CarPlay® and Android Auto™¹ allow you to stay connected.

Help yourself become a better driver with the standard Performance Data Recorder². When activated, it logs video of your drive onto an SD memory card. Three modes allow you to capture video, audio, driving stats, date and time, and much more.

The Head-Up Display (HUD) system offers three distinct views for Tour, Sport and Track modes. Tour mode includes speed limit and turn-by-turn navigation prompts. Sport mode includes digital speed, tachometer and a g-force indicator. Track mode includes digital speed, tachometer, shift lights, best lap time, current lap time and gain/loss.



WIRELESS CHARGING³

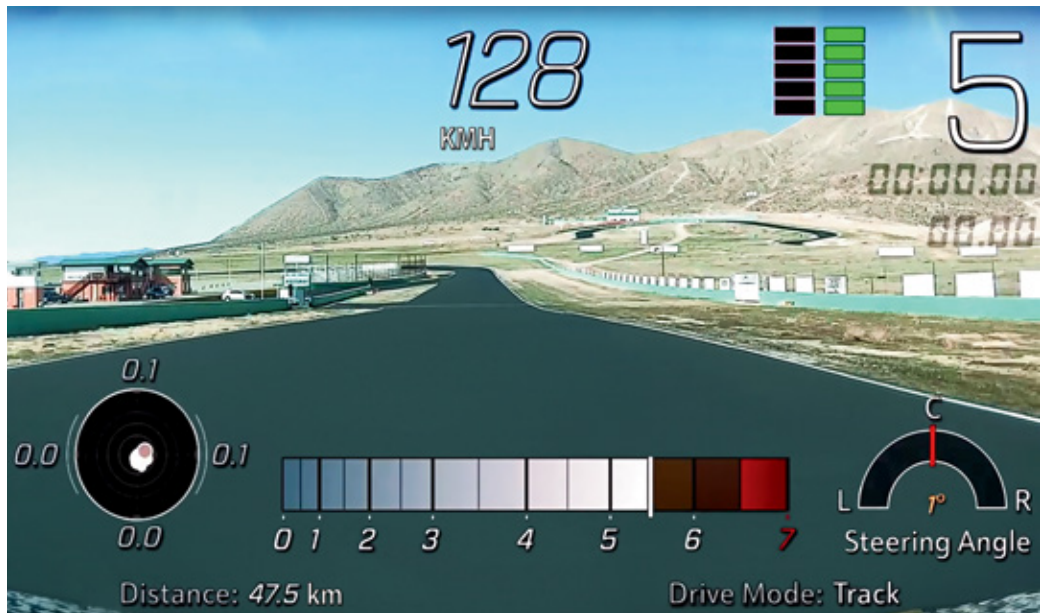

PERFORMANCE DATA RECORDER

¹ Vehicle user interfaces are products of Apple and Google and their terms and privacy statements apply. Requires compatible smartphone and data plan rates apply. Android Auto™ requires a smartphone running Android Lollipop 5.0 OS or above; Apple CarPlay™ requires an iPhone 5 or later. Full lists of supported apps are available at [Apple.com/ios/carplay](https://apple.com/ios/carplay) and [Android.com/auto](https://android.com/auto). Please note that availability of apps may vary by market. ² The driver has to ensure compliance with privacy law and other applicable laws when using the PDR System. Such laws may in particular restrict or exclude the use of the PDR-System on public streets. ³ The system wirelessly charges one PMA- or Qi- compatible mobile device. Mobile phone must support wireless charging for functionality.

SEATING



GT1 | OPTIMIZED FOR COMFORT AND SUPPORT



GT2 | NAPPA LEATHER AND CARBON-FIBER INSERTS

COMPETITION SPORT | EXTRA SUPPORT FOR TRACK DRIVING

THREE WAYS TO BECOME ONE WITH YOUR CORVETTE.

Becoming one with a car means you're properly situated behind the controls. Corvette offers three different seats for different driver preferences, all in a multitude of color combinations and contrasting color seat belts.

The GT1 seat in Mulan leather provides an intelligent balance between excellent support for enthusiastic driving and easy entry/egress for regular driving use.

The available GT2 seat in Nappa leather blends the comfort of the GT1 seat with the appearance and carbon-fiber trim of the Competition Sport seat. Sueded microfiber or two-tone leather inserts are available.

The available Competition Sport provides aggressive bolsters for track driving, with a performance textile in high-wear areas.



CARGO SPACE



FRONT TRUNK



REAR TRUNK

Stingray is equipped with two trunks, one in the front and one in the rear behind the engine, for luggage, coolers, groceries and more. Both coupe and convertible offer the same feet of cargo area. The front trunk will accommodate a standard carry-on roller bag as well as a medium backpack. The rear trunk will carry up to two sets of golf clubs or the removable roof panel (coupe). This kind of versatility makes Stingray a real-world grand touring machine.



COLORS



ARCTIC WHITE

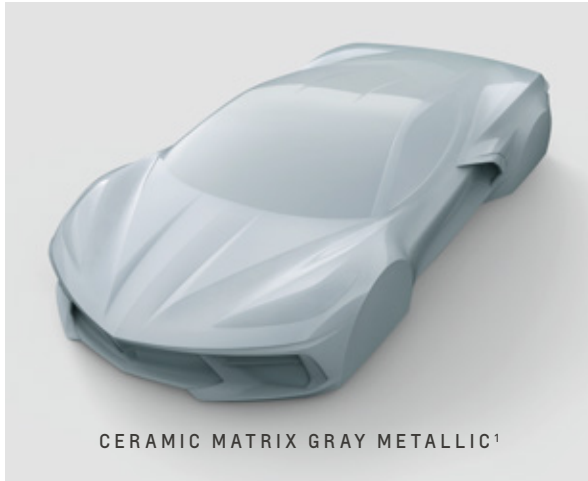

CERAMIC MATRIX GRAY METALLIC¹



FLARE SILVER METALLIC¹



HYPERSONIC GRAY METALLIC¹

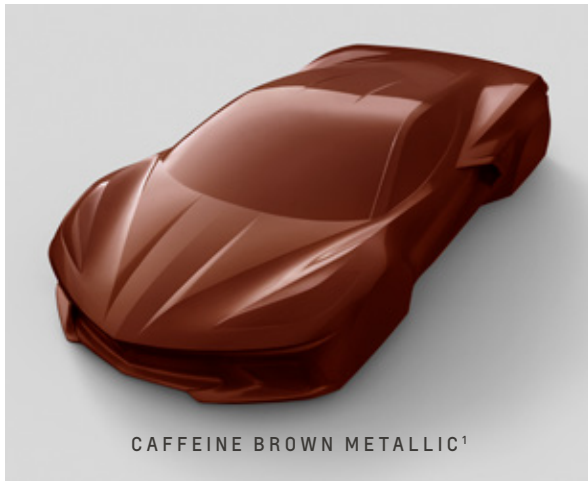

CAFFEINE BROWN METALLIC¹



ACCELERATE YELLOW METALLIC¹



TORCH RED



TACTICAL RED TINTCOAT¹



AMPLIFY ORANGE TINTCOAT¹



RAPID BLUE¹



ELKHART LAKE BLUE METALLIC¹



BLACK

¹Available at extra cost.

GRAPHICS

-



-  EDGE BLUE
-  CARBON FLASH
-  MIDNIGHT GRAY
-  EDGE RED
-  STERLING SILVER
-  EDGE YELLOW



CARBON FLASH/
EDGE RED



CARBON FLASH/
EDGE YELLOW



CARBON FLASH/
MIDNIGHT SILVER

AVAILABLE¹ FULL-LENGTH DUAL RACING STRIPE PACKAGE IN EDGE ORANGE

AVAILABLE¹ HOOD STINGER STRIPES

WHEELS

-



19" X 8.5" FRONT AND 20" X 11" REAR
5-OPEN-SPOKE
BRIGHT SILVER-PAINTED ALUMINUM WHEELS



19" X 8.5" FRONT AND 20" X 11" REAR
5-TRIDENT-SPOKE
MACHINED-FACE STERLING SILVER-PAINTED ALUMINUM WHEELS¹



19" X 8.5" FRONT AND 20" X 11" REAR
20-SPOKE
GLOSS BLACK PAINTED FORGED ALUMINUM WHEELS¹



19" X 8.5" FRONT AND 20" X 11" REAR
5-OPEN-SPOKE
CARBON FLASH-PAINTED ALUMINUM WHEELS WITH MACHINED EDGE¹



19" X 8.5" FRONT AND 20" X 11" REAR
5-TRIDENT-SPOKE
MACHINED-FACE SPECTRA GRAY-PAINTED ALUMINUM WHEELS¹



19" X 8.5" FRONT AND 20" X 11" REAR
20-SPOKE BRIGHT
MACHINED-FACE AFTER MIDNIGHT PAINTED FORGED ALUMINUM WHEELS¹

CALIPER COLORS

-



STANDARD BLACK-PAINTED BRAKE CALIPERS



AVAILABLE BRIGHT RED-PAINTED BRAKE CALIPERS¹



AVAILABLE EDGE RED-PAINTED BRAKE CALIPERS¹



AVAILABLE EDGE YELLOW-PAINTED BRAKE CALIPERS¹

¹ Available at extra cost.

SEAT BELT COLORS



BLACK / ORANGE / NATURAL / TENSION BLUE / TORCH RED / YELLOW

INTERIOR COLORS

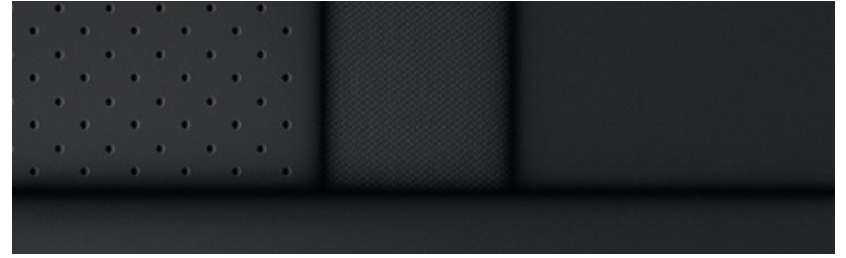

JET BLACK

2LT MULAN LEATHER | PERFORATED INSERTS
2LT/3LT NAPPA LEATHER | PERFORATED INSERTS
2LT/3LT NAPPA LEATHER | PERFORATED SUEDED MICROFIBER INSERTS¹

SEATS GT1 / GT2 / COMPETITION SPORT

RECOMMENDED SEAT BELT COLORS



INTERIOR CONFIGURATIONS | SELECT EXAMPLES AND OPTIONS SHOWN



JET BLACK INTERIOR | 3LT | NAPPA LEATHER | COMPETITION SPORT SEATS | ADRENALINE RED CUSTOM STITCHING² | TORCH RED SEAT BELTS

¹Standard seat belt color. ²Stitching not available for UK market.

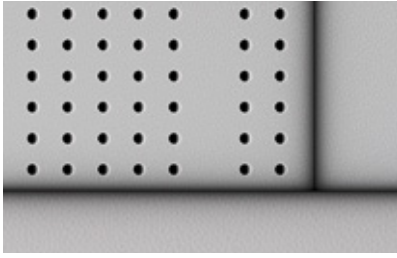

SKY COOL GRAY

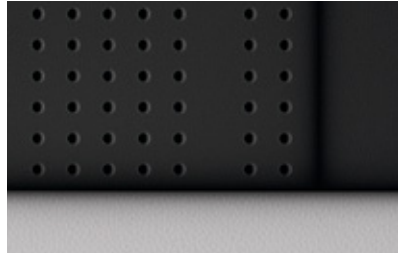

TWO-TONE SKY COOL GRAY¹



ADRENALINE RED

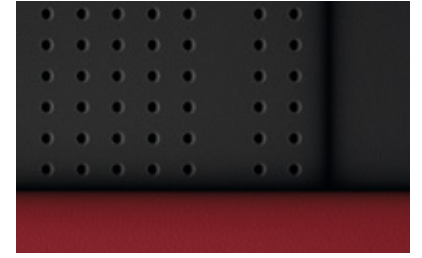

TWO-TONE ADRENALINE RED¹

2LT MULAN LEATHER | PERFORATED INSERTS
2LT/3LT NAPPA LEATHER | PERFORATED INSERTS
2LT/3LT NAPPA LEATHER | PERFORATED SUEDED MICROFIBER INSERTS²

2LT MULAN LEATHER | PERFORATED INSERTS
2LT/3LT NAPPA LEATHER | PERFORATED INSERTS
2LT/3LT NAPPA LEATHER | PERFORATED SUEDED MICROFIBER INSERTS²

SEATS GT1 / GT2 / COMPETITION SPORT

SEATS GT1 / GT2 / COMPETITION SPORT

RECOMMENDED SEAT BELT COLORS



RECOMMENDED SEAT BELT COLORS



SKY COOL GRAY INTERIOR | 2LT | MULAN LEATHER | GT1 SEATS | BLACK SEAT BELTS



ADRENALINE RED INTERIOR | 2LT | MULAN LEATHER | GT1 SEATS | TORCH RED SEAT BELTS

¹ Requires GT2 seats. ² Includes sueded microfiber-wrapped steering wheel. ³ Standard seat belt color.

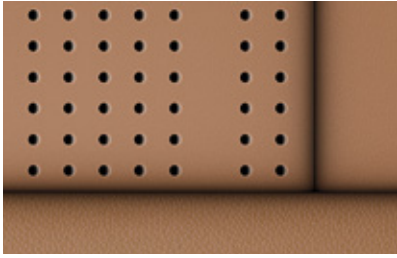

NATURAL



TWO-TONE NATURAL¹

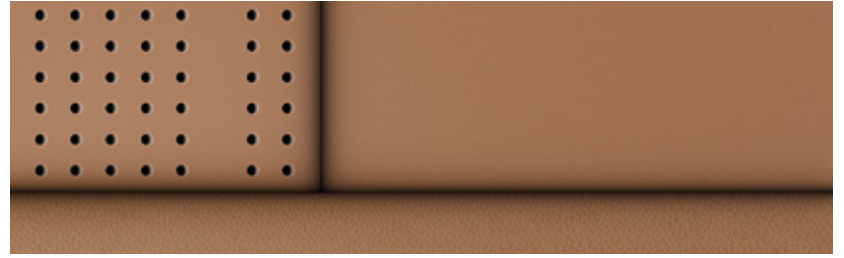

NATURAL-DIPPED²

2LT MULAN LEATHER | PERFORATED INSERTS
2LT/3LT NAPPA LEATHER | PERFORATED INSERTS
2LT/3LT NAPPA LEATHER | PERFORATED SUEDED MICROFIBER INSERTS³

3LT NAPPA LEATHER | PERFORATED INSERTS
3LT NAPPA LEATHER | PERFORATED SUEDED MICROFIBER INSERTS³

SEATS GT1 / GT2 / COMPETITION SPORT

SEATS GT2 / COMPETITION SPORT

RECOMMENDED SEAT BELT COLORS



RECOMMENDED SEAT BELT COLORS

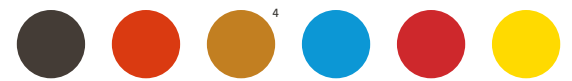

NATURAL INTERIOR | 2LT | MULAN LEATHER | GT1 SEATS | BLACK SEAT BELTS



NATURAL-DIPPED² INTERIOR⁵ | 3LT | NAPPA LEATHER | GT2 SEATS | NATURAL SEAT BELTS

¹Requires GT2 seats. ²Full-color interior includes instrument panel, doors and carpet. This interior features light color throughout and may require extra care to avoid soiling. ³Includes sueded microfiber-wrapped steering wheel. ⁴Standard seat belt color. ⁵Also features available carbon-fiber cluster surround and console/door switch plates.



TENSION BLUE/TWILIGHT BLUE-DIPPED¹

3LT NAPPA LEATHER | PERFORATED INSERTS

SEATS GT2 / COMPETITION SPORT

RECOMMENDED SEAT BELT COLOR



ADRENALINE RED-DIPPED¹

3LT NAPPA LEATHER | PERFORATED INSERTS

SEATS GT2 / COMPETITION SPORT

RECOMMENDED SEAT BELT COLORS



TENSION BLUE/TWILIGHT BLUE-DIPPED¹ INTERIOR³ | 3LT | NAPPA LEATHER | GT2 SEATS | TENSION BLUE SEAT BELTS



ADRENALINE RED-DIPPED¹ INTERIOR | 3LT | NAPPA LEATHER | GT2 SEATS | TORCH RED SEAT BELTS

¹Full-color interior includes instrument panel, doors and carpet. ²Standard seat belt color. ³Also features available carbon-fiber cluster surround and onsole/door switch plates.





—

THE EUROPEAN CORVETTE EXPERIENCE.

—

The former Corvette Racing driver Oliver Gavin is ready to share his racing passion with you!

Whether you already own a Corvette or would like to experience the new Corvette Stingray up close, the Oliver Gavin Driving Academy has the right adventure in store for you. The European Corvette Experience offers a wide range of driving events, trainings, track days, and fascinating tours all over Europe.

Join the dynamic events with the new Corvette Stingray along with fellow enthusiasts and feel the passion of driving a Corvette.

www.corvette-experience.com



Oliver Gavin - Corvette Racing's All-Time Leader
20 Seasons (2002 - 2021)
204 Starts
5 Championships
51 Wins
25 Pole Positions
5 times 24 Hours of Le Mans Winner
5 Sebring Wins



CHEVROLET CORVETTE STINGRAY

ENGINE DATA	
Engine:	6,2 L V8 direct-injection petrol engine with variable valve timing and Active Fuel Management (cylinder deactivation technology)
Valvetrain:	Overhead valve, two valves per cylinder; dual-equal variable valve timing
Valve size (mm):	54 hollow (intake); 40.4 sodium filled (exhaust)
Bore (mm):	103,25
Stroke (mm):	92,0
Displacement (cc):	6162
Compression ratio:	11.5 : 1
Firing order:	1-8-7-2-6-5-4-3 (all cylinders); 1-7-6-4 (with deactivation)
Fuel requirements:	Petrol
Max. engine power (kW/HP at min⁻¹):	354/482 @ 6450
Max. torque (Nm at min⁻¹):	613 @ 4500
Max. engine speed (min⁻¹):	6600
Top speed (mph):	184
Acceleration 0 - 62 mph (sec):	3,5
Oiling system:	Dry sump-type, includes oil-spray piston cooling
Engine oil, capacity (l):	7,1
Cooling system capacity (l):	21,8
Fuel tank capacity (l):	70
FUEL CONSUMPTION AND CO ₂ EMISSIONS (WLTP) ¹	
Fuel consumption, combined (mpg):	23,3
CO₂ emission, combined (g/km):	277
Energy efficiency category:	M
Emission class:	Euro 6d
TRANSMISSION	
Transmission, type:	8-speed, dual clutch (DCT)
Gear ratios:	
1st ratio	2,905
2nd ratio	1,759
3rd ratio	1,220
4th ratio	0,878
5th ratio	0,653
6th ratio	0,508
7th ratio	0,397
8th ratio	0,329
Reverse ratio	2,632
Final drive ratio	5,17
CHASSIS AND SUSPENSION	
Drive axle:	Rear-Wheel Drive (RWD)
Front suspension:	Short / long arm (SLA) double wishbone, forged aluminum upper and cast aluminum Lshape lower control arms; monotube shock absorbers (46mm); Magnetic Selective Ride Control and Front Lift available
Rear suspension:	Short / long arm (SLA) double wishbone, forged aluminum upper and cast aluminum Lshape lower control arms; direct-acting stabilizer bar; monotube shock absorbers (46mm); Magnetic Selective Ride Control available
Steering type:	Variable-ratio rack-and-pinion with electric power assist; includes Active Steer Stops with available Magnetic Selective Ride Control
Steering ratio:	15.7 : 1
Turning circle, curb-to-curb (m):	11.6 11.1 (with Magnetic Selective Ride Control)
BRAKES AND WHEELS	
Brakes, type:	Front and rear e-boost-assisted discs with Brembo four-piston monobloc caliper
Brake rotor size, front (mm):	345 x 30
Brake rotor size, rear (mm):	350 x 27
Wheel size front/rear:	19 X 8.5 J / 20 X11 J
Tires front/rear:	Michelin® Pilot® Sport 4S, 245/35ZR19 front and 305/30ZR20 rear, high performance, run-flat, summer-only tires ²

¹The WLTP figures shown have been measured as per the Worldwide Harmonised Light Vehicle Test Procedure (WLTP) according to Regulation (EC) No 715/2007 in the version valid for type-approval of the vehicle model concerned.

Figures shown are for comparability purposes; only compare fuel consumption and CO₂-emissions figures with other vehicles tested to the same technical procedures. These figures may not reflect real life driving results, which will depend upon a number of factors including the accessories fitted (post-registration), variations in weather conditions, driving styles and vehicle load. The figures do not relate to a specific vehicle and are not part of an offer.

²Do not use summer-only tires in winter conditions, as it would adversely affect vehicle safety, performance and durability. Use only GM-approved tire and wheel combinations. Unapproved combinations may change the vehicle's performance characteristics. For important tire and wheel information, please contact your Chevrolet Partner. Low-profile tires wear faster, and wheel and tire damage may occur on rough or damaged roads from surfaces or kerbs, debris or obstacles. This damage is not covered by the GM New Vehicle Limited Warranty.

SPECIFICATIONS

MASSES AND DIMENSIONS ³	
Mass in running order (kg):	1730 - 1740 (Coupe)
	1767 - 1775 (Convertible)
Max. permissible laden mass (kg):	1980
Max. permissible axle mass front/rear (kg):	810 / 1175
Length (mm):	4634
Width (mm):	1934
Height (mm):	1235 (Coupe)
	1234 (Convertible)
Wheelbase (mm):	2722
Track front/rear (mm):	1647 / 1590
Ground clearance, without front lift (mm):	Between the axles: 81
	Under the front axle: 135
	Under the rear axle: 127
Overhang front/rear (mm):	1037 / 875
Approach angle (degrees at base curb weight):	8,0
Departure angle (degrees at base curb weight):	13,8
Weight distribution front/rear:	40/60

³ Masses and dimensions measured in accordance with the current version of regulation (EU) No 1230/2012.

OWNER BENEFITS

We have created a comprehensive suite of owner benefits, providing everything our Chevrolet owners need and everything they deserve.

CHEVROLET SERVICE

Whether you are at home or on the road, our Chevrolet Partner is there to offer you truly personal assistance. Count on us to arrange service appointments, answer questions about your new Chevrolet and ensure you are always satisfied with your ownership experience. To find your nearest Chevrolet Partner, visit www.chevrolet-europe.com.

WARRANTY

Every Chevrolet is built to the highest standards and is manufactured with the utmost care. As a Chevrolet owner, you can expect nothing less than premium service and protection. Should you experience defects in materials or through deficient workmanship your entire vehicle is backed by our no excess, Bumper-to-Bumper, Limited Chevrolet Warranty for three years or 60.000 miles - whichever comes first, plus a 6-year anti-perforation corrosion warranty. Should the vehicle change owner, the warranty transfers automatically during the warranty period.

CHEVROLET ROADSIDE ASSISTANCE

In the event of an emergency, help is only a phone call away. Contact Chevrolet Roadside Assistance, and we'll come to you as quickly as possible - 24 hours a day, 365 days a year. If we can't return you to the road straight away, we'll take you to the nearest Chevrolet Partner. Chevrolet Roadside Assistance is yours free of charge for a period of 36 months from the date of first registration. Ask your local Chevrolet Partner for details.

ABOUT THIS BROCHURE

The information contained in this brochure was accurate at the time of going to press (June 2022). Availability, technical features and equipment provided on our vehicles can vary from one market to another and may change without prior notice. The vehicles shown in this brochure are for illustration purposes only. European specifications may vary. Some illustrations feature equipment that is not included in every model. The colors printed in the brochure only approximate actual colors.

This material shall not be reprinted, in whole or in part, without the express written permission of General Motors. We reserve the right to make changes at any time, without notice, to prices, colors, materials, equipment, specifications, models and availability.

© 2022 General Motors. All rights reserved.

GM, the GM logo, Chevrolet, the Chevrolet logo and the slogans, emblems, vehicle model names, vehicle body designs and other marks appearing in this brochure are the trademarks of General Motors, its subsidiaries, affiliates or licensors. Bose is a registered trademark of Bose Corporation. Brembo is a registered trademark of Brembo S.p.A. Michelin and Pilot are registered trademarks of Michelin North America, Inc.

www.chevrolet-europe.com

Cadillac Europe GmbH, a company registered under the laws of Switzerland and having its registered office at Boulevard Lilienthal 6, 8152 Glattpark

RACING



A CHAMPIONSHIP

ITS FIRST YEAR OUT.

In the inaugural year of the all-new C8.R, Corvette Racing achieved a dream season, competing against the best Europe has to offer and clinching the 2020 GTLM Manufacturers, Drivers and Team titles for Chevrolet in the IMSA WeatherTech SportsCar Championship. Led by the yellow and silver No. 3 C8.R and the silver and yellow No. 4 C8.R, the team added to an already

impressive list of championships – 113 race victories and eight Le Mans wins since 1999, the most of any competitor. It's all for a very good reason – to make sure that Corvette remains one of the best sports cars in the world, via the technical transfer that comes from racing. Corvette fans can continue to applaud the results.

FIND NEW ROADS™

