



Want to save up to £2000* off a new Vauxhall?



You'll want this card



Apply for The GM Platinum Card today

- ✦ 100 Rebate Points when you use your GM Card for the first time - worth £100 off a new Vauxhall
- ✦ 3% of the value of your GM Card purchases as Rebate Points
- ✦ Typical **14.9% APR** variable
- ✦ 0% p. a. on purchases and balance transfers fixed for the first five months from account opening

Call **0845 746 2777** and quote ref:AGM1 or apply online at www.gmcard.co.uk/brochure

The GM Platinum Card is issued by HFC Bank Limited and is available to persons aged 18 years or over and resident in the UK (or 21 and over in the Channel Islands) and is subject to status and conditions. Written quotations are available upon request from The GM Platinum Card, PO Box 3615, Birmingham B3 2RJ. The typical APR quoted is the rate for new customers. *Rebate Points are earned on purchases using The GM Platinum Card. Rebate Points are not earned on Balance Transfers or Cash Advances. You earn money off a new Vauxhall/Saab by accumulating Rebate Points under the Rebate Points Programme. Vauxhall Motors Ltd is solely responsible for the operation of the Rebate Points Programme, which is subject to the Rebate Points Programme Rules. You can redeem up to 2500 Rebate Points subject to the Model Line Maximum which will vary in amount in relation to different Vauxhall/Saab vehicle model lines and unlimited Partner Points. Rebate Points and unlimited Partner Points are redeemable as discounts on a new Vauxhall/Saab vehicle and must be redeemed four years from the issue date. Rebate Points may not be redeemed by Motability Contract Hire customers. 'The GM Card' is a trading name and style of both HFC Bank Limited and Vauxhall Motors Ltd. HFC Bank Limited is authorised and regulated by the Financial Services Authority. Registered Office: North Street, Winkfield, Windsor, Berkshire SL4 4TD. Registered in England No. 1117305. Member HSBC Group. HFC Bank Limited is not a member of the same group of companies as Vauxhall Motors Ltd, Saab GB Limited or GMAC. Vauxhall Motors Ltd, Registered Office: Griffin House, Osborne Road, Luton, Bedfordshire LU1 3YT. Registered in England number 135767.



New Vectra New Signum Specifications



Contents	
Equipment	S.2-S.8
Audio, Communication and Navigation	S.9
Technical data	S.10-S.17
Vauxhall by Design	S.18
Customer care	S.19

Dodge higher premiums with Vauxhall Motor Insurance



We know you look after your car but who should you trust to insure it? Whatever you drive, Vauxhall Motor Insurance fits the bill. Packed with extra features such as Keycare cover, it's the insurance your car would choose. Plus when you use a Vauxhall approved repairer, we'll even provide a Vauxhall courtesy car (subject to availability for the duration of the repair) and a 3 year guarantee on all repairs. So call today for a quote and see how much you could save.

Call Vauxhall Motor Insurance today

0870 024 0240

www.vauxhall.co.uk/insurance

Vauxhall Motor Insurance is underwritten by UK Insurance Limited. Calls may be recorded. Conditions apply.



Every effort has been made to ensure that the contents of this publication were accurate and up-to-date at the time of going to press (September 2005). Vauxhall vehicles are equipped with components manufactured by various General Motors operating units and outside suppliers. The Company reserves the right to alter specifications and withdraw products from sale without notice. Any such alterations will be notified to Vauxhall retailers at the earliest opportunity, please consult your local retailer for the latest information. The specifications detailed within this brochure are not necessarily applicable to alternative models such as Special Editions. Details of any such models will be contained in specific literature or found on the Vauxhall website. Please note that Vauxhall retailers are not the agents of Vauxhall Motors Limited and are not authorised to bind the Company by any specific or implied undertaking or representation. It is advisable to ensure that your motor insurance policy provides adequate cover for additional fitted options and accessories. As part of Vauxhall's policy of environmental care, this brochure is printed on paper manufactured using Elemental Chlorine Free pulps from specially farmed, sustainable timber resources. All rights reserved. No part of this publication may be reproduced in any form or by any means, without the prior written permission of Vauxhall Motors Limited.

Published September 2005 (Graymatter) Vauxhall Motors Limited, Luton LU1 3YT www.vauxhall.co.uk

VM0505744



EQUIPMENT

Vectra SRi Nav model

An additional model to the Vectra range is the SRi Nav, which features the CD 70 stereo radio/CD with MP3 capability/satellite navigation with colour monitor as standard.



Foldable key



Six airbags



Remote control security alarm

Model availability

	New Vectra						New Signum			
	Life	Club	Exclusiv	Design	Elite	SRi	Elegance	Exclusiv	Design	Elite
4-door saloon	■	■		■						
5-door hatchback	■	■	■	■	■	■				
5-door estate	■	■	■	■	■	■				
5-door executive hatch							■	■	■	■

■ = This model is available with this bodystyle.

Safety

Standard features • Driver's airbag • Front passenger's airbag • Front seat side-impact airbags • Full-size curtain airbags • Anti-lock Braking System (ABS) • Traction control (exc. 1.8i 16v) • Electronic Brakeforce Distribution (EBD) • Cornering Brake Control (CBC) – see **D7** on page S.17 • Emergency Brake Assist (EBA) – Increases brake force applied in emergency braking situations – see **D6** on page S.16 • Active-safety front seat head restraints • Height-adjustable head restraints on outer rear seats • Five lap and diagonal inertia-reel seatbelts (height-adjustable front and outer rear) • Pyrotechnic front and outer rear body-lock seatbelt pretensioner system – Tightens the seatbelt during the early stages of a frontal impact • Front seatbelt force limiters – Reduces potential upper body injuries during a frontal impact • Outer rear seatbelt force limiters (excludes Vectra estate) • ISOFIX child seat system for outer rear seats (does not include child seat) – Secures ISOFIX child safety seats to the vehicle itself, virtually eliminating the dangers that can result from improper installation • Anti-submarining ramps in all seats – Help prevent occupants sliding underneath the lap belt during a collision • Energy-absorbing steering column • Pedal release system – Reduces potential injury to the driver's legs and feet during a severe frontal impact • Laminated windscreen • Side-impact protection beams • Integral protective side door padding • Reinforced passenger safety cell • Deformation zones front and rear • Child-proof locks on rear doors • Burst-proof door locks and anti-jam door design • Adaptive Brake Lights (ABL) – If the driver brakes hard enough to activate the ABS function, ABL illuminates an extra area within the rear light, thus warning following vehicles that heavy braking is in progress.

Additional features	New Vectra						New Signum			
	Life	Club	Exclusiv	Design	Elite	SRi	Elegance	Exclusiv	Design	Elite
Trailer Stability Programme (TSP)	□	□	□	□	□	□	□	□	□	□
Electronic Stability Programme (ESP-plus) D1	□	□	□	□	● ¹	● ¹	□	□	● ¹	● ¹
Isolation facility for electrically operated rear windows				●	●		●	●	●	●
Electronic park/brake pedal safety interlock on models with automatic transmission	●	●	●	●	●	●	●	●	●	●
Height-adjustable centre rear seat head restraint				●	●		●	●	●	●

● = Standard equipment.
 ○ = Optional at extra cost.
 □ = Only available as part of an extra-cost option pack.
 See page S.8 for details.

1 = ESP-plus is standard on V6 models and available as part of Towing pack on all other models.
 2 = Sunroof deletes storage pocket between sunvisors.

3 = Check control warning display features engine oil level, engine coolant level, automatic transmission control (where fitted), front brake pad wear, windscreen washer fluid level, bulb test for head/tail and brake lights, and brake lights fuse. Trip computer features instantaneous and average fuel consumption, fuel consumed, average speed, distance travelled and range based on fuel remaining.

Electronic Stability Programme-plus (ESP-plus)

D1. ESP-plus provides enhanced yaw compensation during understeer or oversteer. The system works by monitoring the front and rear of the car, comparing their respective directions of travel going in to the bend with the input received through the steering wheel. If the vehicle starts to slide, it applies corrective braking to the appropriate wheel, or wheels, compensating for the slide and helping you regain control more rapidly.

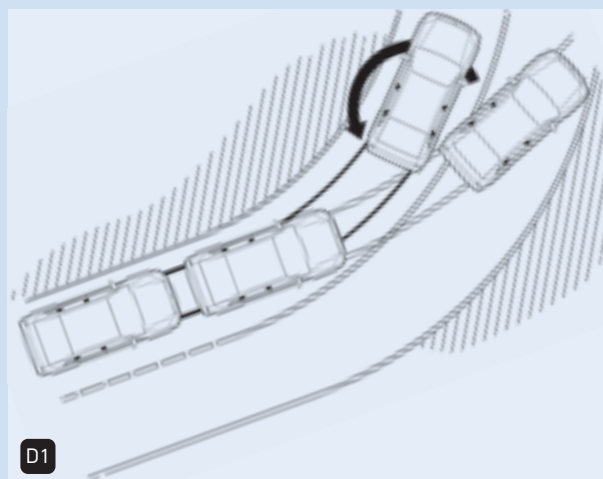

D1

Security

Standard features • Remote control ultrasonic security alarm system • Remote control central deadlocking (doors, boot lid/tailgate, petrol/diesel fuel flap) • Visible Vehicle Identification Number (VIN) plate • 'Key left in ignition' audible warning • Freewheeling driver's door lock • Electronic engine deadlock immobiliser • Door-to-door illumination – Keeps the headlights and rear lights on for 30 seconds after the car doors are locked • Foldable key • Electronic theft protection for audio equipment • Driver's internal central locking switch

Additional feature	New Vectra						New Signum			
	Life	Club	Exclusiv	Design	Elite	SRi	Elegance	Exclusiv	Design	Elite
Locking wheel bolts for alloy wheels	□	●	□	●	●	●	●	●	●	●

Interior features

Standard features • Front and rear tilting assist handles with damped retraction and coat hooks • Chrome internal door handles • Colour-keyed fleece velour carpet • Lidded glovebox • Front door pockets • Hinged luggage compartment cover (hatchback) • Retractable luggage compartment cover (estate/Signum) • Fully carpeted luggage area • Carpeted rear seat back • Boot/load area sill protection • Load restraint lashing eyes • 12-volt auxiliary power socket behind front seats • Drinks holders in centre console

Additional features	New Vectra						New Signum			
	Life	Club	Exclusiv	Design	Elite	SRi	Elegance	Exclusiv	Design	Elite
Twin sunvisors incorporating front passenger's vanity mirror with cover	●	●	●			●				
Twin sunvisors incorporating illuminated driver's and front passenger's vanity mirrors with covers				●	●		●	●	●	●
Charcoal metallic-effect inserts on facia and doors	●	●								
Charcoal metallic/fineline dark inserts on facia and doors				●	●					●
Charcoal metallic/aluminium-effect inserts on facia and doors			●			●	●	●	●	
Leather-covered gear knob (manual gearboxes only)				●	●	●		●	●	●
Electro-chromatic anti-dazzle rear-view mirror				●	●				●	●
Storage pocket between sunvisors ²				●	●		●	●	●	●
Rear seat drinks holders				●	●	●	●	●	●	●

Facia, instruments and controls

Standard features • Cruise control • Rev counter • Automatic self-correcting RDS-time clock • Multi-function display panel showing time, date, outside air temperature (with ice warning) and audio display • Steering column adjustable for reach and rake • Electronic odometer and trip odometer • Instrument panel light dimmer • Coolant temperature gauge • Handbrake-on/low brake fluid level and low fuel level warning lights

Additional features	New Vectra						New Signum			
	Life	Club	Exclusiv	Design	Elite	SRi	Elegance	Exclusiv	Design	Elite
Driver information centre incorporating check control warning display and multi-function trip computer ³			○	●	●	●	●	●	●	●
Three-spoke steering wheel	●	●	●							
Three-spoke leather-covered steering wheel				●	●		●	●		●
Three-spoke leather-covered sports steering wheel						●			●	
Sports instruments						●			●	

Interior lighting

Features	New Vectra						New Signum			
	Life	Club	Exclusiv	Design	Elite	SRi	Elegance	Exclusiv	Design	Elite
Fade up/fade down courtesy lights operated by front and rear door switches	●	●	●	●	●	●	●	●	●	●
Illuminated luggage area and glovebox	●	●	●	●	●	●	●	●	●	●
Map reading lights integral with front courtesy light				●	●		●	●	●	●
Two rear reading lights				●	●		●	●	●	●
Indirect night lighting				●	●				●	●

EQUIPMENT



Electrically heated front seats.



Electronic Climate Control (ECC).



Rain-sensitive windscreen wipers.

Seating and upholstery (see pages 40-41 for details)

Standard features • Driver's seat with reach, rake, height, tilt and lumbar adjustment • Front passenger's seat with reach and rake adjustment • Rear seat fold-down centre armrest and load-through facility • Adjustable front centre armrest with storage facility • Storage pockets on front seat backs

Additional features	New Vectra					New Signum				
	Life	Club	Exclusiv	Design	Elite	SRI	Elegance	Exclusiv	Design	Elite
Champion cloth seat trim	●	●								
Scala cloth seat trim			●				●	●		
Duke cloth seat trim						●				
Alpha cloth/Morrocana seat trim				●						
Draht cloth/leather seat trim									●	
Leather seat trim ⁴					●					●
Electrically heated front seats with variable temperature settings					●					●
Sports front seats						●			●	
Front passenger's seat with height, tilt and lumbar adjustment				●	●				●	●

Rear seating and FlexSpace®

Features	New Vectra					New Signum				
	Life	Club	Exclusiv	Design	Elite	SRI	Elegance	Exclusiv	Design	Elite
Boot/load area sill protection	●	●	●	●	●	●	●	●	●	●
Load restraint lashing eyes	●	●	●	●	●	●	●	●	●	●
Fold-out rear seat centre armrest	●	●	●	●	●	●	●	●	●	●
Rear seat drinks holders				●	●	●	●	●	●	●
Two rear reading lights				●	●		●	●	●	●
12-volt auxiliary power socket in luggage compartment (estate)				●	●	●				
Individual outer rear seats with fore and aft and recline adjustment ^{D2}							●	●	●	●
Centre rear seat concealing storage console							●	●	●	●
60/40 split-folding rear seat back	●	●	●	●	●	●				
40/20/40 split-folding rear seat back ^{D2}							●	●	●	●
Rear seats with individual fold-flat facility ^{D2}							●	●	●	●
Vertical load-restraining net (includes fixing points for accessory dog guard) (estate/Signum)	○	○	○	○	○	○	○	○	○	○
Travel Assistant comprising armrest, storage area, twin fold-out tables, electrically-chilled cool box, tidy bin, 2 x 12-volt auxiliary power sockets, drinks holders and portable DVD holder							○	○	○	○

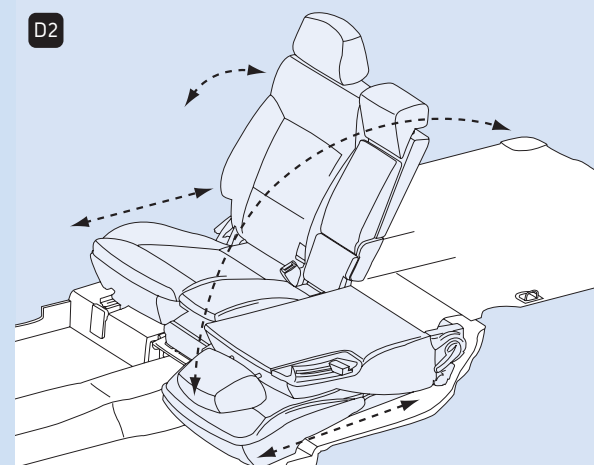

Signum FlexSpace® rear seating

D2. New Signum's rear centre seat is ideal for that occasional fifth passenger. Alternatively you can swivel the padded section to reveal a useful storage console. There's even a pair of built-in drinks holders. Naturally, the seat comes with its own lap and diagonal inertia-reel seatbelt, cleverly concealed in the headlining.

The two individual rear seats are fully contoured, front seat-style, for optimum comfort and support and can be slid back and forth by up to 130mm to achieve the desired mix of legroom/luggage space. In addition, a recline facility for the two individual rear seats lets your passengers achieve their most comfortable travelling position.

The rear seat itself is split 40/20/40 to provide ample space for passengers and/or luggage. The seat cushions of the two individual outer rear seats slide forward as the backs fold in a simple, one-handed movement, creating a large flat load floor.

Heating and ventilation

Standard features • Air blend heater with four-speed fan • Side window demist vents and adjustable face-level air vents • Air recirculation system with activation light • Interior pollen filter • Rear passenger compartment heating ducts

Additional features	New Vectra					New Signum				
	Life	Club	Exclusiv	Design	Elite	SRI	Elegance	Exclusiv	Design	Elite
Air-conditioning	●	●	●			●	●	●	●	
Automatic air-conditioning		□		●						
Electronic Climate Control (ECC) incorporating air-conditioning with variable side-to-side temperature settings and dual zone sun sensor					●					●

Exterior and convenience features

Standard features • Electrically operated front windows with safety autoreverse and one-touch facility • Twin electrically adjustable/heated door mirrors (wide-angle on driver's side) with automatic timed cut-off • Green-tinted glass • Heated rear window with automatic timed cut-off • Intermittent rear window wash/wipe (hatchback/estate/Signum) • Twin-jet windscreen washer nozzles • Twin gas-assisted tailgate struts (hatchback/estate/Signum) • Foldable door mirrors

Additional features	New Vectra					New Signum				
	Life	Club	Exclusiv	Design	Elite	SRI	Elegance	Exclusiv	Design	Elite
Rain-sensitive windscreen wipers with sensitivity adjustment and flick-wipe				●	●				●	●
Two-tone horn			●	●	●	●	●	●	●	●
Electrically operated rear windows with safety autoreverse and child isolation facility				●	●		●	●	●	●
Electrically operated slide/tilt glass sunroof with multi-position pre-set facility and interior blind			○	○ ²	○ ²	○	○ ²	○ ²	○ ²	○ ²
Front and rear parking distance sensors			○	○	○	○	○	○	○	○
Two-coat metallic or pearlescent paint	○	○	○	○	○	○	○	●	○	○
Black roof rails (estate)	○	○								
Silver roof rails (estate/Signum)			○	○	○	○	○	●	○	○
Dark-tinted Solar Protect® glass (excludes windscreen and front door windows) (estate/Signum)						●	●	●	●	●
Detachable tow bar (saloon/hatchback/Signum) ⁵	□	□	□	□	□	□	□	□	□	□
Retractable tow bar (estate) ⁵	□	□	□	□	□	□				
Power tailgate (estate)				●	●					

Mechanical

Standard features • Electro-hydraulic power-assisted steering (EHPS) • Lightweight MacPherson strut front suspension and multi-link rear suspension with gas-pressure dampers • Catalytic converter

Additional features	New Vectra					New Signum				
	Life	Club	Exclusiv	Design	Elite	SRI	Elegance	Exclusiv	Design	Elite
Five-speed manual gearbox (1.8i 16v only)	●	●	●	●		●	●	●	●	
Six-speed manual gearbox (exc. 1.8i 16v)	●	●	●	●	●	●	●	●	●	●
Five-speed automatic transmission with Active Select function (2.2i 16v Direct models)				○	○	○	○	○	○	○
Six-speed automatic transmission with Active Select function (2.8i V6 24v Turbo/1.9CDTi 16v (150PS)/3.0CDTi V6 24v models)	○	○	○	○	○	○	○	○	○	○
Lowered and uprated sports suspension						●	●	●		
Interactive Driving System-plus (IDS-plus) with Continuous Damping Control (CDC) and Sport switch ⁶ ^{D5} – see page S.11			○ ⁷	○ ⁷	○	○ ⁷	○ ⁷	○ ⁷	○ ⁷	○
Automatic self-levelling rear suspension (estate) ⁶	□	□	□	□	□	□	□	□	□	□

● = Standard equipment.
○ = Optional at extra cost.
□ = Only available as part of an extra-cost option pack.
See page S.8 for details.

2 = Sunroof deletes storage pocket between sunvisors.
4 = The following items are upholstered in leather: seat facings and door armrests.
5 = Please note a separate electrical adaptor (13 pin to 7 pin) is required – available as an accessory at extra cost. This adaptor does not allow for supplementary trailer power requirements.

6 = Automatic self-levelling rear suspension is not available in conjunction with 18/19-inch alloy wheels, IDS-plus or sports suspension.
7 = Not available in conjunction with 1.8i 16v or 1.9CDTi (120PS) engines.

EQUIPMENT



Sport switch.



Adaptive Forward Lighting (AFL).



Electro-chromatic anti-dazzle rear-view mirror.

Exterior lighting

Standard features • Lights-on audible warning • LED centre brake light • Twin reversing lights, rear fog light, hazard warning lights, side repeat indicators • Dual Ellipsoidal (DE) headlights • Electric headlight beam levelling										
Additional features	Life	Club	New Vectra				New Signum			
			Exclusiv	Design	Elite	SRI	Elegance	Exclusiv	Design	Elite
Adaptive Forward Lighting (AFL) incorporating xenon headlights with dynamic beam levelling and heated high-pressure headlight washers D3 D4			○	○	○	○	○	○	○	○
Ellipsoidal halogen front fog lights			○	●	●	●		●	●	●
Automatic Lighting Control (ALC)				●	●				●	●

Exterior styling and protection

Standard features • Chrome-effect upper grille surround • Body-colour front and rear bumpers • Body-colour door mirrors • Body-colour side-protection mouldings • Tailgate/boot lid push-lock • Body-colour sports sill mouldings and rear lower skirt (excludes estate)										
Additional features	Life	Club	New Vectra				New Signum			
			Exclusiv	Design	Elite	SRI	Elegance	Exclusiv	Design	Elite
Chrome-effect lower grille surround							●	●	●	●
Chrome-effect front fog light surrounds								●	●	●
Chrome-effect window trim			●	●	●	●	●	●	●	●
Body-colour door handles			●	●	●	●	●	●	●	●
Body-colour rear lip spoiler (hatchback only)						●				
Body-colour sports front air dam			●	●	●	●	●	●	●	●
Dark-style headlights, tail lights and LED centre brake light with grey indicators and side repeaters						●			●	
White indicators and side repeaters			●	●	●		●	●		●
Visible stainless steel exhaust tailpipe (hatchback)						●			●	
Visible dual branch stainless steel exhaust tailpipes (hatchback) ⁸				●	●	●	●	●	●	●

● = Standard equipment.
○ = Optional at extra cost.
□ = Only available as part of an extra-cost option pack.
See page S.8 for details.

6 = Automatic self-levelling rear suspension is not available in conjunction with 18/19-inch alloy wheels, IDS-plus or sports suspension.
8 = 2.2l 1.6v Direct/2.0l 1.6v Turbo/2.8i V6 24v Turbo/3.0CDTi V6 24v models only.
9 = Also available as part of an extra-cost option pack.
See page S.8 for details.

10 = Includes sports suspension.
11 = Not available on 3.0CDTi V6 24v models. The optional 19-inch alloy wheels will affect the fuel consumption and CO₂ emissions. This may have an effect on the VED band and/or benefit in kind taxation. See page S.12 for details of fuel consumption and CO₂ emissions.

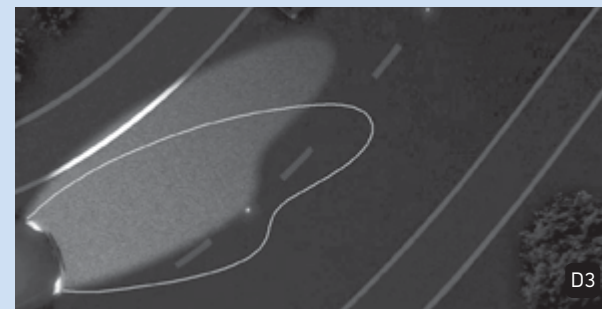

D3

Adaptive Forward Lighting (AFL)

Adaptive Forward Lighting is a sophisticated new lighting system that allows drivers to see around corners and see further ahead at motorway speeds. This optional bi-xenon system employs two main functions:

Curving Light

D3. Controlled by a combination of steering wheel movement and sensors for the vehicle's speed and yaw angle, the Curving Light function allows the headlight beam to move up to 15 degrees left or right of the straight ahead position. This ensures the light is always following the trajectory plotted by the front wheels, rather than simply pointing straight ahead.

Motorway Light

D4. At speeds above 65mph, AFL raises the dipped headlight beam to extend the range of vision for increased safety at higher speed. The beam automatically returns to its normal position when the car falls below that speed.

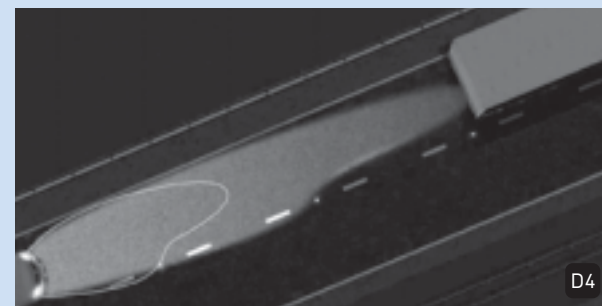

D4

Wheels and tyres

Features	Life	Club	New Vectra				New Signum			
			Exclusiv	Design	Elite	SRI	Elegance	Exclusiv	Design	Elite
16-inch steel wheels with flush wheel covers and 205/55 R 16 ultra-low profile tyres	●									
16-inch five-spoke alloy wheels with locking bolts and 205/55 R 16 ultra-low profile tyres	○ ⁹	●								
16-inch Structure wheels with 215/55 R 16 ultra-low profile tyres			●							
16-inch 10-spoke alloy wheels with 215/55 R 16 ultra-low profile tyres				●						
17-inch seven-spoke alloy wheels with locking bolts and 215/50 R 17 ultra-low profile tyres				□						
17-inch five-spoke alloy wheels with locking bolts and 215/50 R 17 ultra-low profile tyres					□	●	●	●	●	●
18-inch multi-spoke alloy wheels with locking bolts and 225/45 R 18 ultra-low profile tyres ⁶										○ ¹⁰
18-inch 11-spoke alloy wheels with locking bolts and 225/45 R 18 ultra-low profile tyres ⁶							○ ¹⁰	○ ^{9,10}	○ ¹⁰	●
19-inch five-spoke alloy wheels with locking bolts and 235/35 R 19 ultra-low profile tyres (excluding 3.0CDTi V6 24v) ⁶								○ ^{9,11}		○ ¹¹
Space-saver steel spare wheel/tyre	●	●	●	●	●	●	●	●	●	●
Tyre valve cap tool located behind fuel flap	●	●	●	●	●	●	●	●	●	●

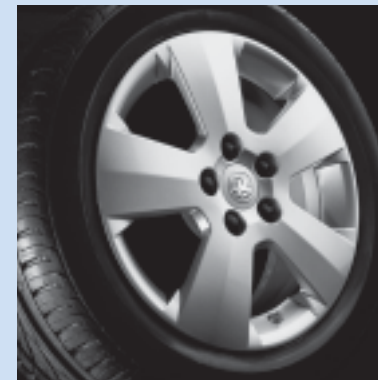

16-inch five-spoke alloy wheel, optional on Life models.

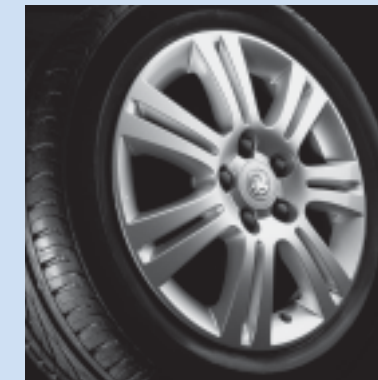

17-inch seven-spoke alloy wheel, optional as part of Plus pack on Vectra Exclusiv models.



17-inch five-spoke alloy wheel, optional as part of Plus pack on Vectra Design models.



18-inch 11-spoke alloy wheel, optional on Vectra Design/Elite and Signum Elegance models.

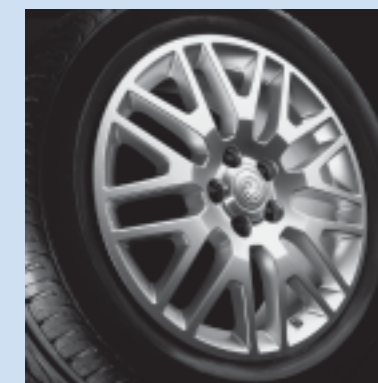

18-inch multi-spoke alloy wheel, optional on Signum Elite models.



19-inch five-spoke alloy wheel, optional on Vectra SRI and Signum Design models.

Option packs

	New Vectra					New Signum					
	Life	Club	Exclusiv	Design	Elite	SRI	Elegance	Exclusiv	Design	Elite	
Plus pack • 16-inch alloy wheels (steel space-saver spare) with 205/50 R 16 tyres • CDC 40 stereo radio with Digital Audio Broadcast (DAB)/integral six-disc CD autochanger/graphic display	○										
Plus pack • Automatic air-conditioning • CDC 40 stereo radio with Digital Audio Broadcast (DAB)/integral six-disc CD autochanger/graphic display		○									
Plus pack • 17-inch alloy wheels (steel space-saver spare) with 215/50 R 17 tyres • CDC 40 stereo radio with Digital Audio Broadcast (DAB)/integral six-disc CD autochanger/graphic display • Front fog lights			○								
Plus pack • 17-inch alloy wheels (steel space-saver spare) with 215/50 R 17 tyres • CD 70 stereo radio/CD with MP3 capability/satellite navigation system with colour monitor				○							
Plus pack • 18-inch alloy wheels (steel space-saver spare) with 225/45 R 18 tyres • Electrically operated slide/tilt glass sunroof with multi-position pre-select facility ²					○ ¹⁰						
Plus pack • 19-inch alloy wheels (steel space-saver spare) with 235/35 R 19 tyres • CDC 40 stereo radio with Digital Audio Broadcast (DAB)/integral six-disc CD autochanger						○ ¹¹					
Towing pack ¹² (hatch/saloon) • Electronic Stability Programme-plus (ESP-plus) • Trailer Stability Programme • Automatic self-levelling rear suspension ⁶ • Detachable tow bar ⁵	○	○	○	○	○ ¹³	○ ¹³	○	○	○ ¹³	○ ¹³	
Towing pack ¹² (estate) • Electronic Stability Programme-plus (ESP-plus) • Trailer Stability Programme • Automatic self-levelling rear suspension ⁶ • Retractable tow bar ⁵	○	○	○	○	○ ¹³	○ ¹³					
Smoker pack • Cigar lighter • Front and rear ashtrays	○	○	○	○	○	○	○	○	○	○	
FlexOrganiser® organiser pack • 3D storage net • Side net pocket • Four side rail hooks (estate)	○	○	○	○	○	○					
FlexOrganiser® divider pack • Vertical divider mesh • Divider rod • Two side rail hooks (estate)	○	○	○	○	○	○					

● = Standard equipment.
○ = Optional at extra cost.

2 = Sunroof deletes storage pocket between sunvisors.
5 = Please note: a separate electrical adaptor (13-pin to 7-pin) is required – available as an accessory at extra cost. This adaptor does not allow for supplementary trailer power requirements.
6 = Automatic self-levelling rear suspension is not available in conjunction with 18/19-inch alloy wheels, IDS-plus or sports suspension.
9 = Also available as part of an extra-cost option pack. See above for details.
10 = Includes sports suspension.
11 = Not available on SRI Nav models and 3.0CDTi V6 24v models. The optional 19-inch alloy wheels will affect the fuel consumption and CO₂ emissions. This may have an effect on the VED band and/or benefit in kind taxation. See page S.12 for details of fuel consumption and CO₂ emissions.

12 = 1.8i 16v models are also fitted with traction control at no extra cost.
13 = ESP-plus is standard on 2.8i V6 24v Turbo/3.0CDTi V6 24v models.
14 = Fitted in lieu of CD 70 audio system. Deletes the satellite navigation function.
15 = Not available on SRI Nav models.
16 = Standard on SRI Nav models.
17 = Deletes drinks holders in centre console. Does not include phone or cradle.

Audio and communications

Standard features • Radio data system (RDS EON) with Traffic Programme • Remote audio display • Roof-mounted flexible aerial • FM and MW reception • Steering wheel mounted audio controls

Additional features	New Vectra					New Signum				
	Life	Club	Exclusiv	Design	Elite	SRI	Elegance	Exclusiv	Design	Elite
CD 30 stereo radio/CD player/six speakers (seven speakers on SRI models) (17 watts per channel)	●	●	●			●				
CDC 40 stereo radio with Digital Audio Broadcast (DAB) facility/integral six-disc CD autochanger/graphic display/seven speakers (35 watts per channel)	○ ⁹	○ ⁹	○ ⁹	●	N/C ¹⁴	○ ^{9,15}	N/C ¹⁴	N/C ¹⁴	N/C ¹⁴	N/C ¹⁴
CD 70 stereo radio/CD with MP3 capability/satellite navigation with graphic display/seven speakers (20 watts per channel)							●		●	
CD 70 stereo radio/CD with MP3 capability/satellite navigation with colour monitor/seven speakers (20 watts per channel)	○	○	○	○ ⁹	●	○ ¹⁶		●		●
Mobile phone system with Bluetooth ^{®17}	○	○	○	○	○	○	○	○	○	○

Digital Audio Broadcast (DAB)

Vauxhall was the first mainstream manufacturer to offer an audio unit with DAB capability as a factory fitted option and, as such, has become the market leader. Digital audio broadcasts differ from FM in that they are entirely immune to interference and offer a sound quality as good as a CD. Of course, to fully appreciate this sound quality it is important

to hear DAB through a high quality sound system, which is why the CDC 40 DAB-compatible audio unit is supplied with our highest quality speaker system, offering up to 45 watts per channel through its speakers.

Mobile phone system

Vauxhall's factory-fit dual-band mobile phone system has been considerably enhanced. Now fully integrated into the audio and communication system, it also features voice control and will connect wirelessly to phones with Bluetooth[®] technology.

All the required information is displayed on the graphic information display when a mobile phone is in use, while the menus are easily navigated by either the steering wheel audio controls or the multi-

function button on the radio. Certain functions can also be controlled by voice activation.

Mounted on the centre console, the phone system base unit can be fitted with cradles (available as accessories) for many different mobile phones. Contact your Vauxhall retailer for information regarding compatible mobile phones.

MP3 CD player

An MP3 is a compressed sound or music file which, due to its small size, takes up less space on a compact disc, which means that more tracks can be recorded onto a CD. It's possible to fit almost 10 hours of music onto one CD, and, in a way, turns a single-disc CD/MP3 player into a multi-disc autochanger.

Providing you have access to a compatible computer to create the MP3 tracks, you can compress your CD collection and create your own compilations – and you won't have to drive around with all your original CDs in the car.

Satellite navigation

Vauxhall's CD-ROM-driven satellite navigation systems have been widely acclaimed for their ease of use and high level of information. On models with a colour monitor a split-screen facility displays half the screen as a map and half as easy-to-follow directional arrows.

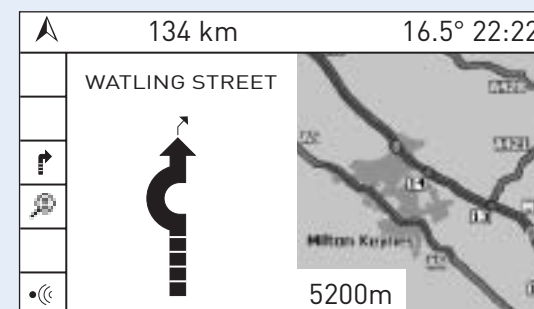

The audible direction guidance prompt gives details of road numbers and motorway junction numbers, while you can also plan your route to avoid toll roads, if required.

The CD 70 also features Traffic Message Channel (TMC), a specific application of RDS used for broadcasting real-time traffic information, delivered to the driver either visually or verbally. TMC can also offer dynamic route guidance – alerting the driver to a problem on the planned route and calculating an alternative route to avoid the incident.

Standard features (CD 70) • Automatic re-routing on request • CD-ROMs available for all major European countries • CD-ROM may be replaced by audio CD after route is selected • Display of estimated time remaining and distance to destination • Exact location of vehicle using the GPS (Global Positioning System) and speed sensor • Choice of four different route types • Store up to 100 personal destinations • Last 10 destinations stored automatically

TECHNICAL DATA



330Nm

New 2.8i V6 24v Turbo – maximum torque at only 1800rpm



184PS

3.0CDTi V6 24v – now more powerful and more efficient



6-SPEED

Six-speed manual and automatic transmissions widely available

Petrol engines

	1.8i 16v ECOTEK-4	2.2i 16v Direct ECOTEK-4 aluminium	2.0i 16v Turbo ECOTEK-4 aluminium	2.8i V6 24v Turbo ECOTEK-4 aluminium
Capacity	1796cc	2198cc	1998cc	2792cc
Maximum power	122PS (90kW) @ 6000rpm	155PS (114kW) @ 5600rpm	175PS (129kW) @ 5500rpm	230PS (169kW) @ 5500rpm
Maximum torque	167Nm (123 lb.ft.) @ 3800rpm	220Nm (162 lb.ft.) @ 3800rpm	265Nm (195 lb.ft.) @ 2500rpm	330Nm (243 lb.ft.) @ 1800rpm
Compression ratio	10.5:1	12.0:1	9.5:1	9.5:1
Emission compliance	Euro 4	Euro 4	Euro 4	Euro 4
Layout	4 cylinders 4 valves per cylinder Double overhead camshafts	4 cylinders 4 valves per cylinder Double overhead camshafts	4 cylinders 4 valves per cylinder Double overhead camshafts	6 cylinders 4 valves per cylinder Double overhead camshafts
Construction	Alloy cylinder head Cast iron cylinder block	Alloy cylinder head Alloy cylinder block	Alloy cylinder head Alloy cylinder block	Alloy cylinder heads Alloy cylinder block
Fuel system	Multi-point sequential fuel injection with high-pressure fuel pump	Multi-point sequential direct fuel injection with high-pressure fuel pump	Multi-point sequential fuel injection with air mass metering	Multi-point sequential fuel injection with air mass metering
Induction system	Naturally aspirated	Naturally aspirated	Water-cooled turbocharger with intercooler	Water-cooled twin-scroll turbocharger with intercooler
Throttle control	Electronic cable-free 'drive by wire'			
Service interval	20,000 miles or 1 year (whichever occurs sooner)			
Benefit in kind company car taxation percentage rates – 2005/06 tax year				
	Hatchback/Saloon/Estate/Signum			
Manual*	22 (SRi 23)/22/25/25	23/23/24/25	28/-/29/29	-/-/-/35
Automatic*	-/-/-/-	25/25/26/26	-/-/-/-	35/-/35/35

Diesel engines

	1.9CDTi (120PS) ECOTEK-4 turbo diesel	1.9CDTi 16v (150PS) ECOTEK-4 turbo diesel	3.0CDTi V6 24v ECOTEK-V6 turbo diesel	
Capacity	1910cc	1910cc	2958cc	
Maximum power	120PS (88kW) @ 3500rpm	150PS (110kW) @ 4000rpm	184PS (135kW) @ 4000rpm	
Maximum torque	280Nm (206 lb.ft.) @ 2000-2750rpm	315Nm (232 lb.ft.) @ 2000-2750rpm	400Nm (295 lb.ft.) @ 1900-2700rpm	
Compression ratio	18.0:1	17.5:1	18.5:1	
Emission compliance	Euro 4	Euro 4	Euro 4	
Layout	4 cylinders 2 valves per cylinder Single overhead camshaft	4 cylinders 4 valves per cylinder Double overhead camshafts	6 cylinders 4 valves per cylinder Double overhead camshafts	
Construction	Alloy cylinder head Cast iron cylinder block	Alloy cylinder head Cast iron cylinder block	Alloy cylinder heads Alloy cylinder block	
Fuel system	Common rail fuel injection system with high-pressure pump			
Induction system	Turbocharger with Variable Nozzle Turbine (VNT)			
Throttle control	Electronic cable-free 'drive by wire'			
Service interval	20,000 miles or 1 year (whichever occurs sooner)			
Benefit in kind company car taxation percentage rates – 2005/06 tax year**				
	Hatchback/Saloon/Estate/Signum			
Manual*	17/17/18/18	18/18/18/19	24/-/24/24	
Automatic*	-/-/-/-	24/24/24/24	tba	

- = This engine/body style/transmission combination is not available.

* = For details of benefit in kind percentage rates relating to models fitted with optional 19-inch alloy wheels please refer to the Vauxhall Car and Accessory Price Guide.

** = A 3% increase applies from 6 April 2006 for vehicles registered from 1 January 2006.

tba = To be advised.

Transmissions

- Front-wheel drive
- Hydraulically actuated, asbestos-free single-plate clutch

Five-speed manual gearbox: standard on 1.8i 16v. Close-ratio on Vectra 1.8i 16v SRi and all Estate and Signum 1.8i 16v models.

Six-speed manual gearbox: standard on 2.2i 16v Direct/2.0i 16v Turbo/2.8i V6 24v Turbo Signum Design/1.9CDTi (120PS)/1.9CDTi 16v (150PS)/3.0CDTi V6 24v models.

Five-speed automatic transmission with Active Select function: available at extra cost on 2.2i 16v Direct models. Electronically controlled with adaptive driving function and winter mode. Fluid drive with torque converter, lock-up clutch, neutral control fuel-saving feature and Active Select.

Six-speed automatic transmission with Active Select function: standard on 2.8i V6 24v Turbo Elite models and available at extra cost on 1.9CDTi 16v (150PS)/3.0CDTi V6 24v models. Electronically controlled with adaptive driving function and winter mode. Fluid drive with torque converter, lock-up clutch, neutral control fuel-saving feature and Active Select.

Electrics

Alternator:

1.9CDTi/1.9CDTi 16v – 100A.
1.8i 16v/2.2i 16v Direct/2.0i 16v Turbo – 120A.
2.8i V6 24v Turbo – tba.
3.0CDTi V6 24v – 140A.

Maintenance-free battery:

1.8i 16v – 55Ah.
1.9CDTi/1.9CDTi 16v – 70Ah.
2.2i 16v Direct/2.0i 16v Turbo – 66Ah.
2.8i V6 24v Turbo – tba.
3.0CDTi V6 24v – 85Ah.

Fuel tank capacity

- Vectra hatchback/saloon – 61 litres (13.4 gallons)
- Vectra estate/Signum – 60 litres (13.2 gallons)

Suspension

Front: Independent. Lightweight MacPherson struts with gas-pressure dampers and coil springs. Anti-roll bar. Lightweight aluminium uprights and control arms.

- Vectra SRi/Signum Exclusiv and Design – uprated springs and dampers with lower ride height

Rear: Lightweight multi-link with rising-rate steel double cone mini-block coil springs and gas-pressure dampers. Aluminium lower control arm/upright reduces unsprung weight for enhanced ride/roadholding. Compact packaging ensures minimal intrusion into luggage area. Mounting bushes feature high lateral and low longitudinal stiffness for optimum roadholding and comfort.

- Vectra SRi/Signum Exclusiv and Design – uprated springs and dampers with lower ride height
- Vectra Life, Club, Design and Elite (estate)/Signum Elegance and Elite – automatic self-levelling rear suspension option

Body

- Aerodynamic drag co-efficient: Hatchback/Saloon – Cd 0.29
Estate – Cd 0.32
Signum – Cd 0.33
- Aluminium and magnesium components utilised to reduce weight
- Extensive use of dual-phase steels
- Polypropylene front and rear bumpers capable of withstanding minor impacts up to 2.5mph without permanent deformation
- High strength alloy steel B-pillar

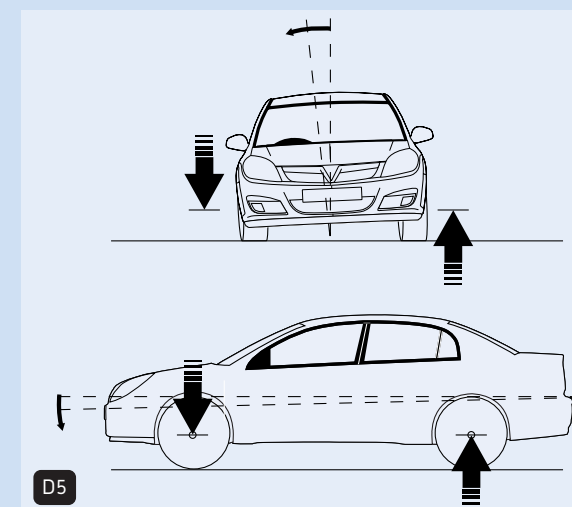

Interactive Driving System-plus (IDS-plus) with Continuous Damping Control (CDC)

D5. The Interactive Driving System (IDS-plus) chassis offers the driver an even more sporting driving experience, thanks mainly to the electronic control of the suspension. Pressing the Sport switch activates the CDC function – CDC monitors the roll, pitch and yaw of the car, and changes the rate of damping on each wheel to optimise the handling, effectively stiffening the suspension – but selectively. This means the vehicle will exhibit a reduced rate of roll and pitch, making it more responsive during direction changes and more settled during the braking/turn-in/acceleration transition when cornering. CDC is a major breakthrough in the segment.

Sport switch

D5. The functions of the Sport switch aren't limited to suspension control. When activated, it also affects the steering and accelerator pedal. The drive by wire throttle is altered electronically, leading to a sharper engine response and crisper acceleration, while the map of the power assisted steering is also adjusted, giving the driver a more positive initial turn-in on corner-entry.

TECHNICAL DATA AND WARRANTIES



60.1mpg

Vectra 1.9CDTi (120PS) engine is both powerful and economical



7.1secs

Signum 2.8i V6 24v Turbo 0-60mph



5.3secs

Vectra 3.0CDTi V6 24v 30-50mph, great torque and flexibility

New Vectra performance, fuel economy and emissions

	Performance (manufacturer's figures)			Wheel size (inches)	Fuel economy mpg (litres/100km)			CO ₂ emissions g/km
	Maximum speed (mph)	Acceleration (sec) 0-60mph	30-50mph (4th gear)		Urban driving	Extra-urban driving	Combined figure	
Manual gearbox								
1.8i 16v (exc. SRI) hatch/saloon	126	10.5	9.8	16/17/18	27.2 (10.4)	51.4 (5.5)	38.7 (7.3)	175
1.8i 16v SRI hatch	127	10.5	8.3	17/18	26.4 (10.7)	48.7 (5.8)	37.2 (7.6)	182
				19	26.2 (10.8)	47.9 (5.9)	36.7 (7.7)	185
1.8i 16v estate	123	11.1	8.4	16/17/18	25.7 (11.0)	46.3 (6.1)	35.8 (7.9)	190
				19	25.4 (11.1)	45.6 (6.2)	35.3 (8.0)	192
2.2i 16v Direct hatch/saloon	135	8.6	7.5	16/17/18	27.4 (10.3)	47.9 (5.9)	37.7 (7.5)	180
				19	27.2 (10.4)	47.1 (6.0)	37.2 (7.6)	182
2.2i 16v Direct estate	130	8.9	7.2	16/17/18	26.6 (10.6)	45.6 (6.2)	36.2 (7.8)	187
				19	26.4 (10.7)	44.8 (6.3)	35.8 (7.9)	190
2.0i 16v Turbo hatch	143	8.1	5.5	17/18	22.6 (12.5)	44.8 (6.3)	32.8 (8.6)	206
				19	22.4 (12.6)	44.1 (6.4)	32.5 (8.7)	209
2.0i 16v Turbo estate	139	8.4	5.9	17/18	22.2 (12.7)	43.5 (6.5)	32.1 (8.8)	211
				19	22.1 (12.8)	42.8 (6.6)	31.7 (8.9)	214
1.9CDTi (120PS) hatch/saloon	124	10.5	7.5	16/17/18	38.2 (7.4)	60.1 (4.7)	49.6 (5.7)	154
				19	37.7 (7.5)	58.9 (4.8)	48.7 (5.8)	157
1.9CDTi (120PS) estate	121	11.2	8.0	16/17/18	37.2 (7.6)	57.6 (4.9)	47.9 (5.9)	159
				19	36.7 (7.7)	56.5 (5.0)	47.1 (6.0)	162
1.9CDTi 16v (150PS) hatch/saloon	135	8.9	6.2	16/17/18	37.7 (7.5)	58.9 (4.8)	48.7 (5.8)	157
				19	37.2 (7.6)	57.6 (4.9)	47.9 (5.9)	159
1.9CDTi 16v (150PS) estate	130	9.5	6.5	16/17/18	37.2 (7.6)	57.6 (4.9)	47.9 (5.9)	159
				19	36.7 (7.7)	56.5 (5.0)	47.1 (6.0)	162
3.0CDTi V6 24v hatch	143	8.2	5.3	16/17/18	28.8 (9.8)	54.3 (5.2)	40.9 (6.9)	186
3.0CDTi V6 24v estate	140	8.6	5.6	16/17/18	28.5 (9.9)	53.3 (5.3)	40.4 (7.0)	189
Automatic transmission								
2.2i 16v Direct hatch/saloon	130	9.5	-	16/17/18	25.0 (11.3)	46.3 (6.1)	35.3 (8.0)	192
				19	24.8 (11.4)	45.6 (6.2)	34.9 (8.1)	194
2.2i 16v Direct estate	129	9.9	-	16/17/18	24.6 (11.5)	44.8 (6.3)	34.4 (8.2)	197
				19	24.4 (11.6)	44.1 (6.4)	34.0 (8.3)	199
2.8i V6 24v Turbo hatch	155	7.2	-	17/18	16.5 (17.1)	38.7 (7.3)	25.9 (10.9)	262
2.8i V6 24v Turbo estate	152	7.4	-	17/18	16.2 (17.4)	37.2 (7.6)	25.2 (11.2)	269
1.9CDTi 16v (150PS) hatch/saloon	130	9.4	-	16/17/18	29.7 (9.5)	52.3 (5.4)	40.9 (6.9)	186
				19	29.4 (9.6)	51.4 (5.5)	40.4 (7.0)	189
1.9CDTi 16v (150PS) estate	129	9.7	-	16/17/18	29.4 (9.6)	51.4 (5.5)	40.4 (7.0)	189
				19	29.1 (9.7)	50.4 (5.6)	39.8 (7.1)	192
3.0CDTi V6 24v hatch	tba	tba	-	16/17/18	tba	tba	tba	tba
3.0CDTi V6 24v estate	tba	tba	-	16/17/18	tba	tba	tba	tba

The fuel consumption figures shown comply with EC directive 1999/100 to provide a realistic indication of fuel consumption by taking into account everyday driving conditions, such as cold starts, acceleration and braking. These figures take account of the vehicle's kerbweight, ascertained in accordance with the above regulation. **Important:** the results given relate to the particular car tested. Variations in trim level and equipment may result in slightly higher fuel consumption and CO₂ emission levels than those quoted. Driving style, road and traffic conditions, vehicle mileage and standard of maintenance may also affect fuel consumption; therefore the results do not express or imply any guarantee of fuel consumption attainable. **tba** = To be advised.

New Signum performance, fuel economy and emissions

	Performance (manufacturer's figures)			Wheel size (inches)	Fuel economy mpg (litres/100km)			CO ₂ emissions g/km
	Maximum speed (mph)	Acceleration (sec) 0-60mph	30-50mph (4th gear)		Urban driving	Extra-urban driving	Combined figure	
Manual gearbox								
1.8i 16v	122	11.2	8.5	17/18	25.7 (11.0)	46.3 (6.1)	35.8 (7.9)	190
2.2i 16v Direct	130	9.1	7.5	17/18	25.9 (10.9)	43.5 (6.5)	34.9 (8.1)	194
				19	25.7 (11.0)	42.8 (6.6)	34.4 (8.2)	197
2.0i 16v Turbo	137	8.4	5.9	17/18	22.1 (12.8)	42.8 (6.6)	31.7 (8.9)	214
				19	21.9 (12.9)	42.2 (6.7)	31.4 (9.0)	216
2.8i V6 24v Turbo	151	7.1	5.2	17/18	18.0 (15.7)	37.2 (7.6)	26.6 (10.6)	254
				19	17.9 (15.8)	36.7 (7.7)	26.4 (10.7)	257
1.9CDTi (120PS)	120	11.2	8.1	17/18	37.2 (7.6)	57.6 (4.9)	47.9 (5.9)	159
				19	36.7 (7.7)	56.5 (5.0)	47.1 (6.0)	162
1.9CDTi 16v (150PS)	129	9.5	6.7	17/18	36.7 (7.7)	56.5 (5.0)	47.1 (6.0)	162
				19	36.2 (7.8)	55.4 (5.1)	46.3 (6.1)	165
3.0CDTi V6 24v	139	8.7	5.7	17/18	28.5 (9.9)	53.3 (5.3)	40.4 (7.0)	189
Automatic transmission								
2.2i 16v Direct	128	10.0	-	17/18	24.4 (11.6)	44.1 (6.4)	34.0 (8.3)	199
				19	24.1 (11.7)	43.5 (6.5)	33.6 (8.4)	202
2.8i V6 24v Turbo	150	7.5	-	17/18	16.2 (17.4)	37.2 (7.6)	25.2 (11.2)	269
1.9CDTi 16v (150PS)	127	9.7	-	17/18	29.4 (9.6)	51.4 (5.5)	40.4 (7.0)	189
				19	29.1 (9.7)	50.4 (5.6)	39.8 (7.1)	192
3.0CDTi V6 24v	tba	tba	-	17/18	tba	tba	tba	tba

The fuel consumption figures shown comply with EC directive 1999/100 to provide a realistic indication of fuel consumption by taking into account everyday driving conditions, such as cold starts, acceleration and braking. These figures take account of the vehicle's kerbweight, ascertained in accordance with the above regulation. **Important:** the results given relate to the particular car tested. Variations in trim level and equipment may result in slightly higher fuel consumption and CO₂ emission levels than those quoted. Driving style, road and traffic conditions, vehicle mileage and standard of maintenance may also affect fuel consumption; therefore the results do not express or imply any guarantee of fuel consumption attainable. **tba** = To be advised.

Vauxhall Assistance and warranties*

Standard features • A one-year unlimited mileage manufacturer's warranty • Second and third year no-fee customer option warranty up to 60,000 miles (from first registration) • Vauxhall Assistance for 12 months from first registration • Roadside breakdown cover in years two and three (subject to vehicle being serviced at a Vauxhall retailer) • Six years' body panel anti-perforation warranty

* = Warranty is only available on vehicles sourced from Vauxhall Motors Ltd. Terms and conditions apply – please see your Vauxhall retailer for details.

Vauxhall Assistance

Vauxhall Assistance is operated by the AA, and is provided automatically with every new Vauxhall for 12 months from first registration. It covers everything from accidents, mechanical breakdown and flat tyres to illness while driving. With Vauxhall Assistance, help is literally just a free** phone call away, 24 hours a day, 365 days a year!

Benefits include:

- Full rescue service including roadside assistance
- 'At home' service – help will be sent if there is a vehicle problem at the driver's home

- Recovery – if a problem cannot be solved at the roadside, or if someone is taken ill while driving, the driver, vehicle and all passengers will be transported to the nearest Vauxhall retailer or to any single UK destination
 - Accident assistance – if your vehicle is immobilised by an accident, both the vehicle and occupants will be recovered to your choice of destination (Vauxhall recommends a Vauxhall Approved Accident Repair Centre, where appropriate)
 - Vehicle theft – Vauxhall Assistance will help to keep you mobile in the unlikely event of your vehicle being stolen
- ** = Mobile phone users will be charged at their standard tariff.

DIMENSIONS

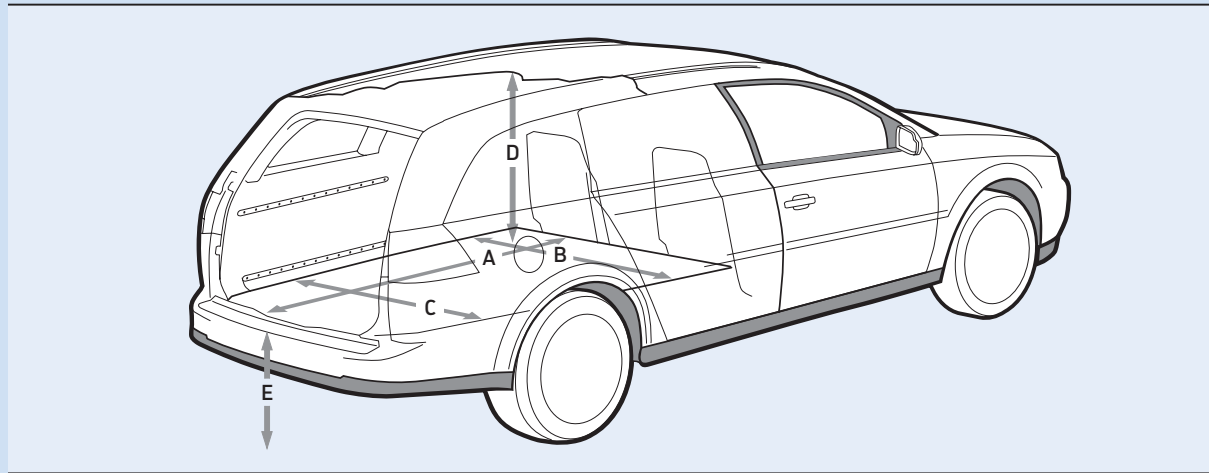

Loadspace dimensions millimetres (inches)

	New Vectra Estate	New Signum
Maximum load floor length – rear seats folded (A)	2046 (80.6)	1833 (72.2)
Maximum load floor length – rear seats up and fully back	1175 (46.3)	931 (36.7)
Maximum load floor length – rear seats up and fully forward	-	1061 (41.8)
Maximum rear floor width (B)	1079 (42.5)	1054 (41.5)
Minimum rear floor width (C)	1060 (41.7)	978 (38.5)
Maximum load area height (D)	850 (33.5)	761 (30.0)
Loading height from ground level (unladen) (E)	608 (23.9)	599 (23.6)
Maximum tailgate aperture width	1089 (42.9)	1035 (40.7)
Maximum tailgate aperture height	767 (30.2)	727 (28.6)
Maximum load area height beneath luggage compartment cover	n/a	599 (23.6)

- = This dimension does not apply to this bodystyle. n/a = This dimension is not available.

Luggage capacities* litres (cu.ft.)

	Hatchback	New Vectra Saloon	Estate	New Signum
Load volume (minimum) under luggage cover – rear seats up	500 (17.7)	500 (17.7)	530 (18.7)	365 (12.9)
Load volume (maximum) to roof – rear seats folded	1050 (37.1)	1050 (37.1)	1850 (65.3)	1410 (49.8)

* = Measured using the ECIE method.

Exterior dimensions millimetres (inches)

Vectra

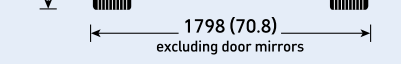
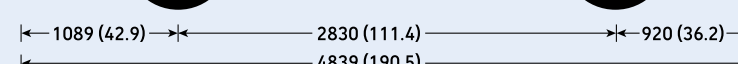
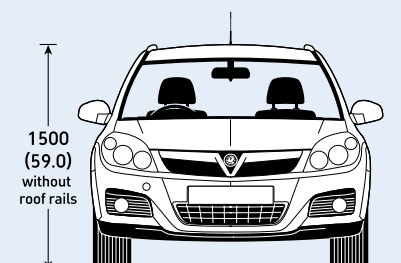
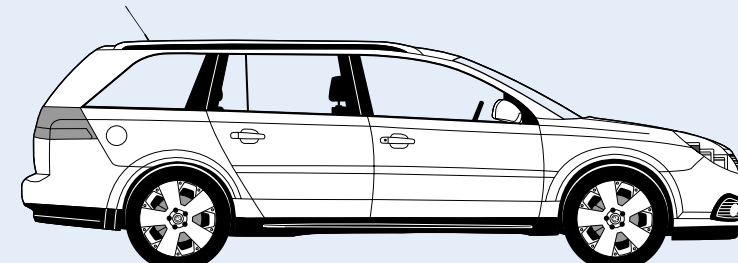
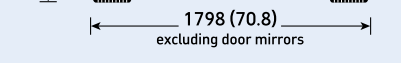
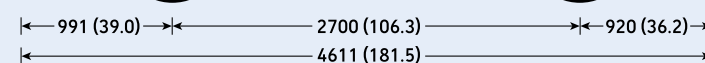
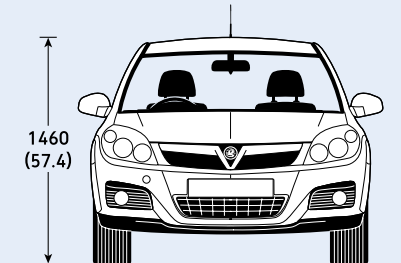
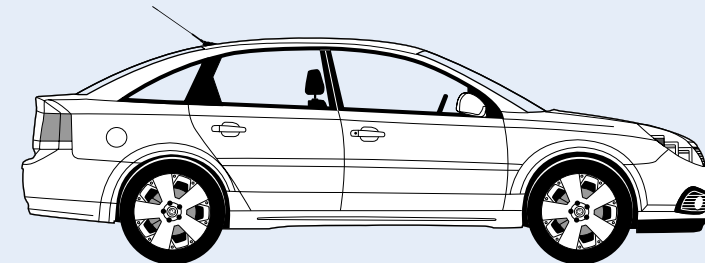
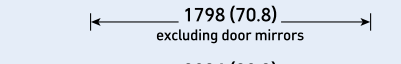
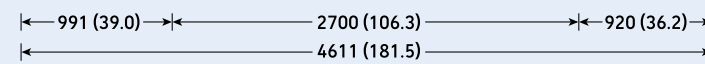
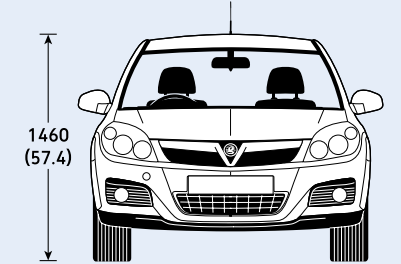
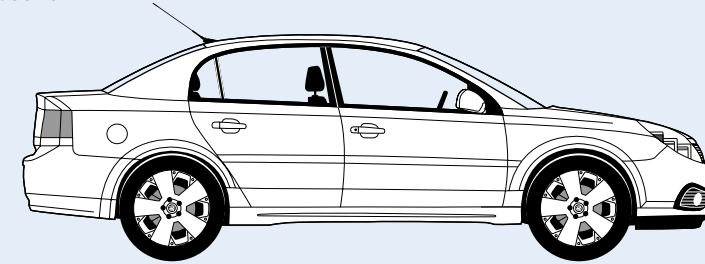

Signum

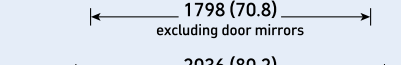
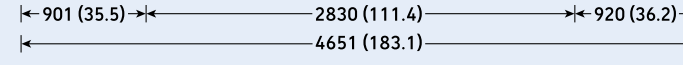
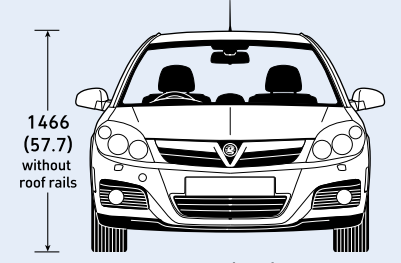
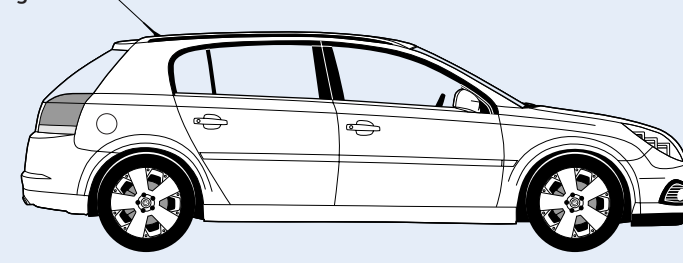

WEIGHTS AND TOWING

Weights and towing data (petrol engined models) kg

	Kerbweight (Gross vehicle weight)				Max. towing weights Trailer with brakes (without brakes)		
	Hatchback	Saloon	Estate	Signum	Hatchback/Sal.	Estate	Signum
1.8i 16v Life/Club/Exclusiv	1335 (1885)	1336 (1870)	1400 (2030)	1438 (2020)	1400 (685)	1300 (735)	-
1.8i 16v Design	1350 (1885)	1352 (1870)	1431 (2030)	-	1400 (685)	1300 (735)	-
1.8i 16v SRi	1346 (1885)	-	1428 (2030)	-	1300 (685)	1300 (735)	-
1.8i 16v Elegance	-	-	-	1438 (2020)	-	-	1400 (740)
2.2i 16v Direct Design/Elite	1431 (1950)	1416 (1935)	1459 (2085)	-	1500 (715)	1600 (750)	-
2.2i 16v Direct Design/Elite (auto)	1461 (1980)	1446 (1965)	1509 (2115)	-	1600 (715)	1600 (750)	-
2.2i 16v Direct SRi	1428 (1950)	-	1456 (2085)	-	1500 (715)	1600 (750)	-
2.2i 16v Direct SRi (auto)	1455 (1980)	-	1506 (2115)	-	1600 (715)	1600 (750)	-
2.2i 16v Direct Elegance/Exclusiv	-	-	-	1493 (2075)	-	-	1500 (750)
2.2i 16v Direct Elegance/Exclusiv (auto)	-	-	-	1523 (2105)	-	-	1600 (750)
2.2i 16v Direct Design	-	-	-	1494 (2075)	-	-	1500 (750)
2.2i 16v Direct Design (auto)	-	-	-	1524 (2105)	-	-	1600 (750)
2.2i 16v Direct Elite	-	-	-	1499 (2075)	-	-	1500 (750)
2.2i 16v Direct Elite (auto)	-	-	-	1529 (2105)	-	-	1600 (750)
2.0i 16v Turbo SRi	1456 (1995)	-	1523 (2125)	-	1600 (730)	1700 (750)	-
2.0i 16v Turbo Elegance	-	-	-	1518 (2100)	-	-	1700 (750)
2.0i 16v Turbo Design	-	-	-	1519 (2100)	-	-	1700 (750)
2.0i 16v Turbo Elite	-	-	-	1524 (2100)	-	-	1700 (750)
2.8i V6 24v Turbo Elite (auto)	1561 (2080)	-	1594 (2215)	-	1600 (750)	1800 (750)	-
2.8i V6 24v Turbo Design	-	-	-	1594 (2175)	-	-	1700 (750)
2.8i V6 24v Turbo Elite (auto)	-	-	-	1619 (2200)	-	-	1700 (750)

Gross vehicle weight is the total permissible weight of the vehicle including passengers and their luggage. To determine total carrying capacity, deduct kerbweight from gross vehicle weight. Note that the figure obtained will include the weight of the driver, passengers and any optional equipment or accessories. The **maximum roof rack loading** should not exceed 100kg. The **maximum towing weights** are based on the ability of the car, with two occupants of 70kg each, to restart on a 12% gradient, which is approximately 1 in 8.3, at sea level. At altitudes above 1500 metres, the engine output may drop with a corresponding reduction in towing capability. Any extra weight, such as luggage or additional passengers, should be deducted from the maximum towing weight. With a trailer fully loaded, **maximum noseweight** should not exceed 78kg. Always fit Vauxhall towing attachments and accessories available from your Vauxhall retailer. They are designed specifically for Vauxhall models and carry a 12-month guarantee.

Weights and towing data (diesel engined models) kg

	Kerbweight (Gross vehicle weight)				Max. towing weights Trailer with brakes (without brakes)		
	Hatchback	Saloon	Estate	Signum	Hatchback/Sal.	Estate	Signum
1.9CDTi (120PS) Life/Club/Exclusiv	1428 (1995)	1430 (1980)	1510 (2140)	1548 (2130)	1500 (750)	1500 (750)	-
1.9CDTi (120PS) Design	1459 (1995)	1461 (1980)	1541 (2140)	-	1500 (750)	1500 (750)	-
1.9CDTi (120PS) SRi	1456 (1995)	-	1538 (2140)	-	1500 (750)	1500 (750)	-
1.9CDTi (120PS) Elegance	-	-	-	1548 (2130)	-	-	1500 (750)
1.9CDTi (120PS) Design	-	-	-	1549 (2130)	-	-	1500 (750)
1.9CDTi 16v (150PS) Life/Club/Exclusiv	1428 (2005)	1430 (1990)	1525 (2155)	1556 (2145)	1600 (750)	1500 (750)	-
1.9CDTi 16v (150PS) Life/Club/Exclusiv (auto)	1473 (2030)	1430 (2015)	1538 (2180)	1581 (1270)	1600 (750)	1500 (750)	-
1.9CDTi 16v (150PS) Design/Elite	1459 (2005)	1461 (1990)	1556 (2155)	-	1600 (750)	1500 (750)	-
1.9CDTi 16v (150PS) Design/Elite (auto)	1504 (2030)	1461 (2015)	1569 (2180)	-	1600 (750)	1500 (750)	-
1.9CDTi 16v (150PS) SRi	1456 (2005)	-	1553 (2155)	-	1600 (750)	1500 (750)	-
1.9CDTi 16v (150PS) SRi (auto)	1501 (2030)	-	1566 (2180)	-	1600 (750)	1500 (750)	-
1.9CDTi 16v (150PS) Elegance	-	-	-	1556 (2145)	-	-	1600 (750)
1.9CDTi 16v (150PS) Elegance (auto)	-	-	-	1581 (2170)	-	-	1600 (750)
1.9CDTi 16v (150PS) Design	-	-	-	1557 (2145)	-	-	1600 (750)
1.9CDTi 16v (150PS) Design (auto)	-	-	-	1582 (2170)	-	-	1600 (750)
1.9CDTi 16v (150PS) Elite	-	-	-	1562 (2145)	-	-	1600 (750)
1.9CDTi 16v (150PS) Elite (auto)	-	-	-	1587 (2170)	-	-	1600 (750)
3.0CDTi V6 24v Elite	1596 (2125)	-	1631 (2240)	-	1600 (750)	1800 (750)	-
3.0CDTi V6 24v Elite (auto)	1621 (2150)	-	1656 (2265)	-	1400 (750)	1200 (750)	-
3.0CDTi V6 24v SRi	1593 (2125)	-	1636 (2240)	-	1600 (750)	1800 (750)	-
3.0CDTi V6 24v SRi (auto)	1618 (2150)	-	1661 (2265)	-	1400 (750)	1200 (750)	-
3.0CDTi V6 24v Design	-	-	-	1659 (2240)	-	-	1700 (750)
3.0CDTi V6 24v Design (auto)	-	-	-	1677 (2265)	-	-	1300 (750)
3.0CDTi V6 24v Elite	-	-	-	1664 (2240)	-	-	1700 (750)
3.0CDTi V6 24v Elite (auto)	-	-	-	1682 (2265)	-	-	1300 (750)

Gross vehicle weight is the total permissible weight of the vehicle including passengers and their luggage. To determine total carrying capacity, deduct kerbweight from gross vehicle weight. Note that the figure obtained will include the weight of the driver, passengers and any optional equipment or accessories. The **maximum roof rack loading** should not exceed 100kg. The **maximum towing weights** are based on the ability of the car, with two occupants of 70kg each, to restart on a 12% gradient, which is approximately 1 in 8.3, at sea level. At altitudes above 1500 metres, the engine output may drop with a corresponding reduction in towing capability. Any extra weight, such as luggage or additional passengers, should be deducted from the maximum towing weight. With a trailer fully loaded, **maximum noseweight** should not exceed 78kg. Always fit Vauxhall towing attachments and accessories available from your Vauxhall retailer. They are designed specifically for Vauxhall models and carry a 12-month guarantee.

Stopping distance at 60mph
Actuating time: 150 milliseconds

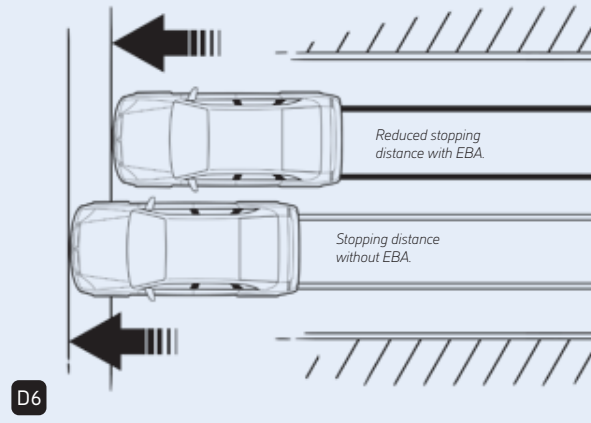

Emergency Brake Assist (EBA)

D6. Emergency brake assist detects the urgency with which the brake pedal is pressed and rapidly increases the pressure to the maximum the system can provide, shortening stopping distances. It also enhances pedal feel.

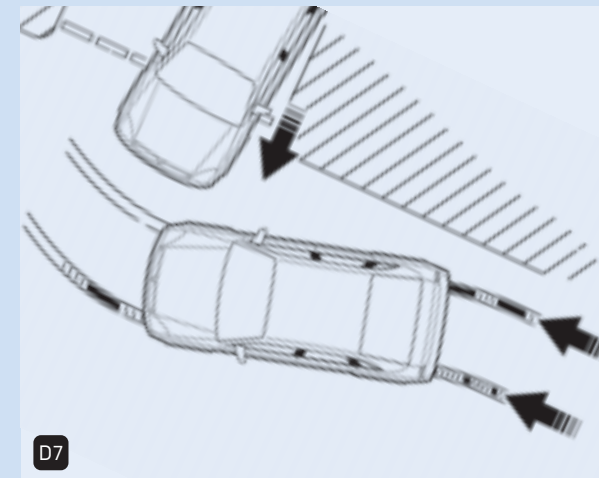

Anti-lock Braking System (ABS) with Cornering Brake Control (CBC)

D7. Cornering brake control makes the car easier to control in extreme situations, particularly when braking sharply on a bend. It is particularly effective when carrying out emergency procedures, such as avoiding a child's ball that's rolled out from the kerb. The system works by sensing the different rotational speeds of the individual road wheels and co-ordinating the level of braking pressure applied to each wheel. CBC is an integral part of New Vectra and New Signum's comprehensive ABS.

VAUXHALL BY DESIGN

Styling and accessories

VXR exterior styling (Vectra only)

- VXR Styling pack one¹
- Front lower spoiler
- Rear lower skirt¹
- Side sills
- Rear roof spoiler (estate)
- Rear lip spoiler (hatch/saloon)

¹ = Not available on Life, Club or Exclusiv models. On Design and Elite models, only available with the following engines: 2.2i 1.6v Direct, 2.0i 1.6v Turbo, 2.8i V6 2.4v Turbo, 3.0CDTi V6 2.4v. Not available with optional parking distance sensors on estate models.

Irmscher exterior styling

- Rear lip/wing/roof spoilers
- Rear bumper sports insert (SRi)
- Protection trim for rear bumper (estate)
- Rear lower skirt (for use with sports silencer)
- Side sills
- Chrome-effect door mirror covers
- Stainless steel door handle covers
- Door handle spoilers
- Side pillar trim kit
- Front lower spoiler
- Cross hatch grilles

Irmscher interior styling

- Velour floor mats with 'Irmscher' logo
- Door lock buttons
- Aluminium pedals (manual)
- Stainless steel interior door sill covers

Irmscher alloy wheels

- Softstar – 16/17-inch
- Twin Spoke – 17-inch
- Spectra Sports Line – 17-inch
- Signa – 16/18-inch
- Sport Star – 16/17/18-inch
- Delta – 17/19-inch²
- Stila – 16/18-inch
- Stila-polished – 18-inch
- Evo Star – 18/20-inch²
- GT Star – 19-inch²

² = Wheel arch modifications may be necessary.

Irmscher sports silencers

- Sports silencer with twin rectangular stainless steel tailpipes
- Sports silencer with dual branched twin rectangular stainless steel tailpipes

Irmscher suspension kit³

- Uprated and lowered spring and suspension kits

³ = Not for use with towing equipment. Excluding Vectra SRi and Signum Exclusiv/Design models.

Child seats⁴

- Vauxhall BABY-SAFE – birth to 13kg
- Vauxhall DUO ISOFIX – 9 to 18kg
- Vauxhall KID – 15 to 36kg
- Baby mirror

⁴ = Restrictions apply regarding the fitment and positioning of child seats. Please consult your Vauxhall retailer for further details.

Safety

- First aid kit
- Warning triangle
- Fire extinguisher – 1 or 2kg
- Temporary tyre repair kit

Security

- Locking wheel bolts
- Steering wheel security bar

Practical

- Spare bulb kit (not for AFL or xenon headlights)
- Jump leads – standard or heavy duty
- Fuel can – 5 or 10 litres
- Stretch tow rope – 2 tonne rated

Exterior

- Mudflaps
- Rear parking distance sensor
- Headlight protectors
- Door wind deflectors (front pair)

Interior – cabin area

- Floor mats
- Front passenger's storage box
- Rear seat protection cover
- Sunblind – rear window (hatchback)
- Storage bag including rucksack
- Waste bag

Interior – load area

- Loading protection for rear bumper
- Anti-slip mat
- Bootliner
- Cargo liner
- Dog guard (estate)⁵
- Space divider grid (for use with dog guard on estate)
- Load-restraining floor net
- Vertical load-restraining net (estate)⁵
- Load-restraining storage net
- Electrically chilled 12-litre cool bag
- Parcel shelf storage bag (hatchback)
- Boot storage box (hatchback/saloon)

⁵ = Requires optional fixing points or accessory fitting kit if vehicle is not equipped with a factory-fit vertical load restraining net option.

FlexOrganiser® (estate)

- 3D storage net
- Side net pocket
- Side rail hooks
- Vertical divider mesh
- Side rail strap
- Fold-flat storage box
- 2-in-1 carry case
- Divider rods
- Hooks for divider rods

Load carriers

Roof carrier system

- T-track base carrier
- Bicycle carriers
- Luggage restraining strap
- Ski/snowboard carrier
- Extendable ski carrier
- Sportboxes/roof box
- Surfboard/windsurf board carrier

Interior carrier system

- Bicycle carrier (estate)

Tow bar carrier system

- Tow bar mounted bicycle carrier (two bicycles)
- Extension for third bicycle

Towing

- Fixed tow bar with electrics
- Detachable tow bar with electrics
- Bumper cut-out cover (for use with detachable tow bar)
- Towing mirrors
- Electrical adaptor (for use with optional towing packs)

Audio, navigation and accessories

- Satellite navigation/stereo radio/CD player systems
- Portable CD storage bag
- Sunvisor CD storage
- Single DIN facia kit

Communications

- Hands-free Bluetooth® mobile phone cradle – suitable for many specific handsets⁶

⁶ = Only suitable for vehicles fitted with the factory-fit Bluetooth® system.

TRUST VAUXHALL

There are more important things to life than worrying about how to finance and service your car, where to go in the event of an accident and how we go about meeting the transport challenges of the future. So when you choose Vauxhall, you can rely on us to safeguard both you and the environment around you, leaving you free to concentrate on the more important business of enjoying your car!

USEFUL CONTACTS

• Vauxhall Mobility	0800 731 5267
• Vauxhall Military/Diplomatic Sales	0870 442 1580
• Vauxhall Rental	0870 442 1567
• Fleet Support	0870 010 0651
• Vauxhall Accident Support	0800 010 304
• Sureguard extended warranty	0870 752 7020
• Vauxhall Insurance	0870 024 0240
• Vauxhall Leasing	0870 737 2557

Protecting the environment

At Vauxhall, we take a broader viewpoint than the design, manufacture and selling of cars. We are committed to looking after the environment throughout the life cycle of the vehicle.

Our products are increasingly winning environmental awards, both through the use of more recycled materials and by becoming cleaner and more efficient. For information on Vauxhall's efforts to achieve an environmentally sustainable future, including information on Design for Recycling, take-back of End-of-Life Vehicles (ELVs), and the recycling of ELVs, see www.vauxhall.co.uk/recycling.

Looking to the future, we are also investing heavily in the biggest potential breakthrough of the next decade – the hydrogen fuel cell car.

Customer Care Commitment

Providing drivers with the highest standards of aftersales support, Vauxhall offers a three-year Customer Care Commitment* package. Highlights include:

- A one-year unlimited mileage manufacturer's warranty
- A second and third year no-fee customer option warranty to 60,000 miles from first registration
- Vauxhall Assistance for 12 months from first registration
- Roadside breakdown cover
- Free loan car

* = Warranty is only available on vehicles sourced from Vauxhall Motors Ltd. Terms and conditions apply – please see your Vauxhall retailer for details.

Anti-perforation warranty

Your new Vauxhall also comes with a body panel anti-perforation warranty for a period of at least six years from the date of first registration.

Vauxhall Assistance

Vauxhall Assistance is operated by the AA and is provided for 12 months from date of first registration and covers everything from accidents, mechanical breakdown and flat tyres to illness while driving. With Vauxhall Assistance, help is literally just a free** phone call away, 24 hours a day, 365 days a year!

** = Mobile phone users will be charged at their standard tariff.

Complete Motoring Plan

Vauxhall's Complete Motoring Plan is a simple way to budget for all your motoring needs. For just a small monthly payment all your car's routine servicing and maintenance is covered[†], you will receive full Vauxhall Assistance cover and MOT test insurance for the duration of the plan. You can buy peace of mind for 24, 36 or 48 months by either an up front payment or interest free direct debit.

[†] = Excludes tyres, exhausts and windscreens. Terms and conditions apply.

Vauxhall Leasing

As Vauxhall's own contract hire and fleet management operation, Vauxhall Leasing provides a one-stop-shop for competitive car and van leasing solutions – for business users and private individuals. Working with the Vauxhall retailer network, we combine the support of a national contract with the convenience of a local contact. For further information, please see your local Vauxhall retailer or call us on 0870 737 2557.

Alternatively, visit our website at www.vauxhall-leasing.co.uk

Buying your car

For straightforward advice on a simple, affordable way into a new or used car ask your Vauxhall retailer. GMAC offers a wide range of finance solutions that are easy to understand, flexible enough to suit every need and convenient to arrange at your Vauxhall retailer.

For more information...

For a brochure on any Vauxhall model (up to a maximum of three per caller) or location of your nearest Vauxhall retailer please **Lo-call 0845 600 1500**.

Alternatively, details can be found on our website at www.vauxhall.co.uk



In the event of an accident...

Vauxhall Accident Support is designed to help keep you mobile following an accident, providing prompt recovery to a Vauxhall Approved Accident Repair Centre where your vehicle can be repaired to a high standard. The service is free to all Vauxhall drivers. For further information *Freefone* 0800 010 304.

Sureguard protection

Should you wish to enjoy the range of benefits provided by Vauxhall Assistance for a full three years from first registration, then new Sureguard Assistance is for you. If you are a higher mileage driver or plan to keep your vehicle for longer than the standard warranty period, you need the protection of Sureguard Warranty. This provides all the peace of mind of a parts and labour warranty – including Assistance – for the duration of your cover. Sureguard Warranty and Sureguard Assistance now come with the added peace of mind of Sureguard MOT Warranty. For details contact your local Vauxhall retailer or call 0870 752 7020.

Specialist Mobility advice

 Motability accredited Vauxhall retailers can provide special mobility help and advice. Blue badge holders are entitled to very favourable discounts when purchasing new vehicles. For full details contact your local Motability accredited Vauxhall retailer or *Freefone* 0800 731 5267.

Servicing and maintenance

The best way to maximise the performance and reliability of your Vauxhall is to have all routine servicing and maintenance carried out at a Vauxhall retailer. There are around 400 retailers nationwide.

For more details ask your retailer for the Car and Accessory Price Guide or visit our website at www.vauxhall.co.uk/accessories