

# *Standard Commercial Vehicles...*

**THE STANDARD 12 CWT DELIVERY VAN**

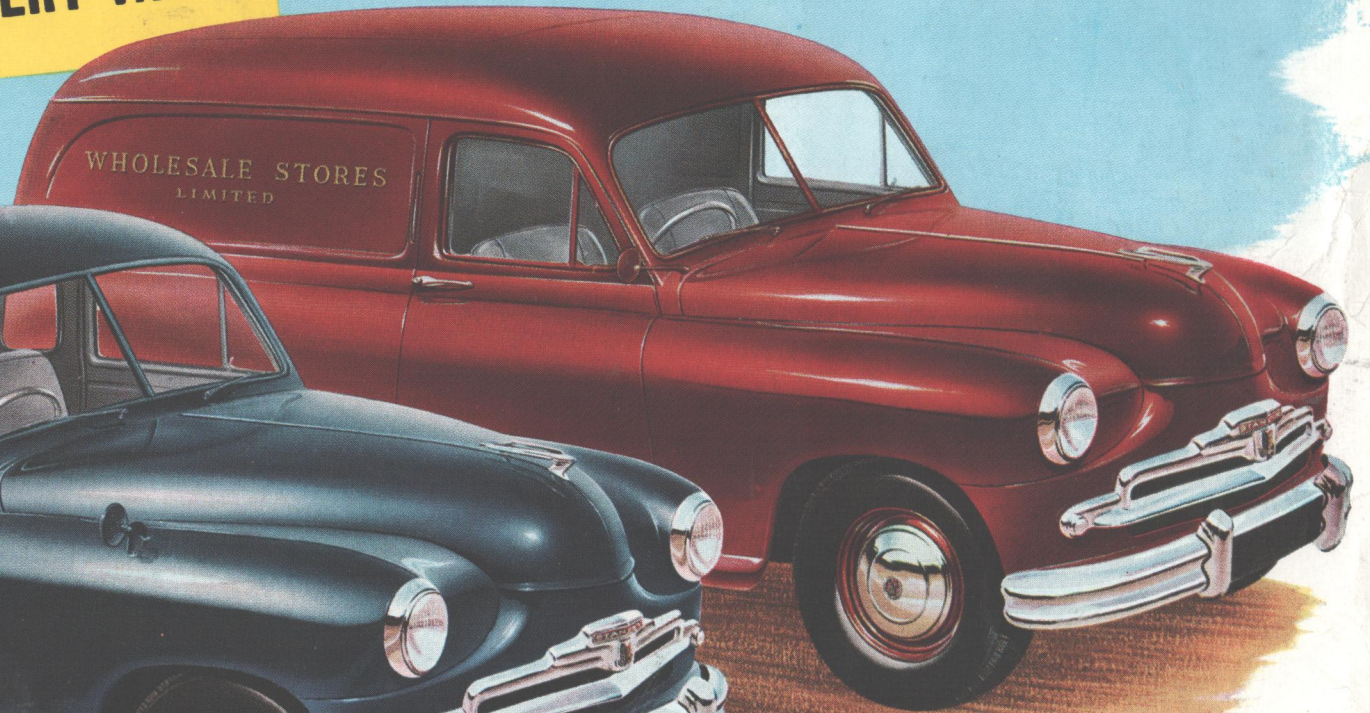

**THE STANDARD PICK-UP TRUCK**

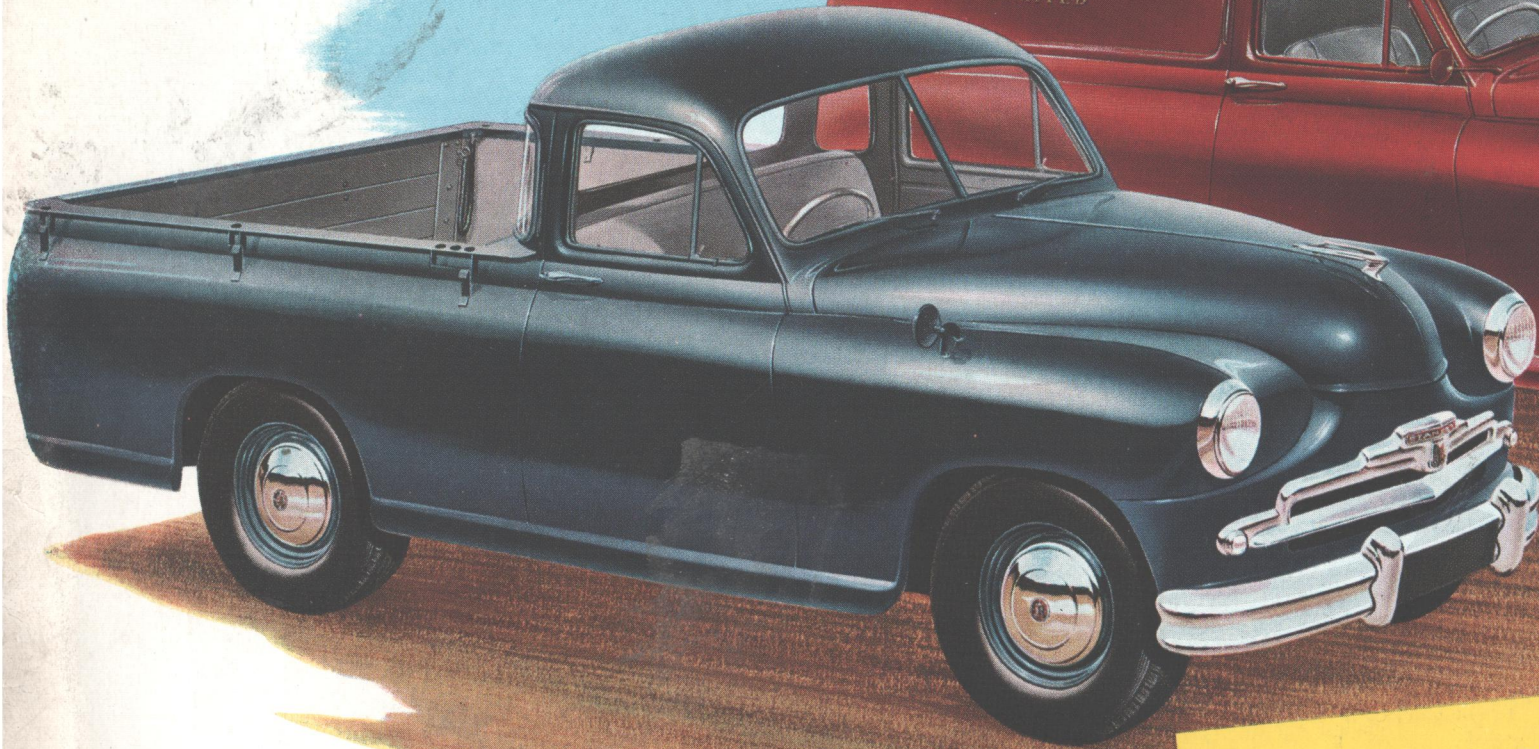



# The Standard Pick-up Truck

## POWERFUL

Whatever the conditions, the power-packed 2-litre engine of the Standard Pick-up Truck will meet them easily and cheerfully. However rough the going or steep the gradient the Pick-up keeps going with ample power in reserve.

## STRENGTH

Its exceptionally rigid, cross-braced chassis frame and the sturdy suspension enables the Standard Pick-up Truck to stand up to the hardest work and most severe stresses day after day.

## PERFORMANCE

The Standard Pick-up Truck, with its 24 miles per gallon, is economical to run, while its lively acceleration and high ground clearance make it ideal for overseas conditions. For still greater economy this model can be fitted with the Standard Diesel Engine, particulars of which are available on request,

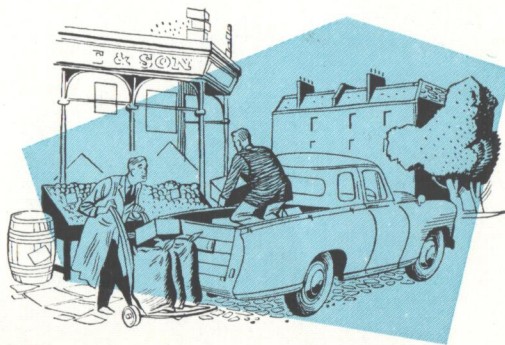
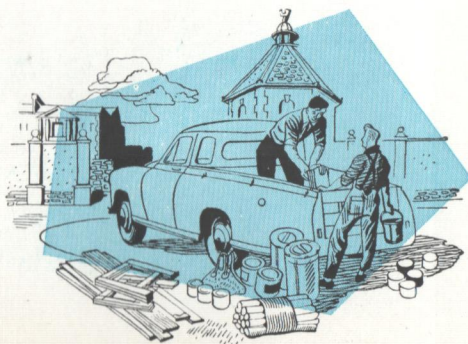
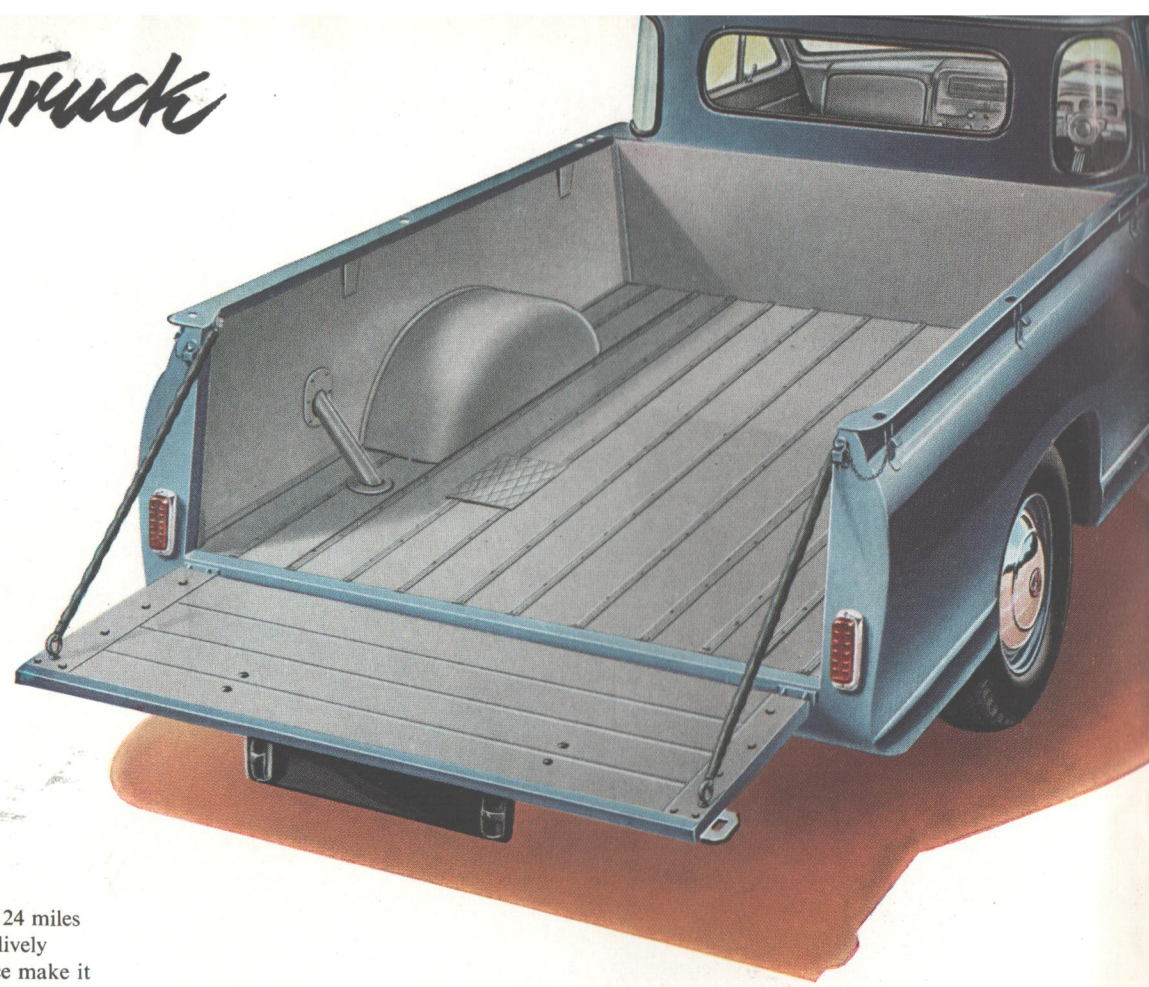



# Built for hard work

**BODY FEATURES:** Pick-up truck type with 2-door cab, steel panelled, finished in primer ready for painting. Sockets for hood poles and rope hooks incorporated either side. Press button door handles. Low level flat floor. Payload capacity 12 cwt. Other features include extra wide rear window and additional corner windows. Anti-draught ventilation by hinged deflector lights in front door windows. Locks to both doors and fuel filler cap. One-piece counterbalanced bonnet with lock-release control operated from inside body. Self-cancelling trafficators controlled from centre of steering wheel. Substantial bumpers at front, chromium plated, matt finish. Twin rear reflectors.

**EQUIPMENT INCLUDES:** Triplex toughened safety glass fitted to all windows. Instruments grouped in front of driver include: speedometer with trip, ammeter, fuel, water temperature and oil pressure gauges. Concealed fascia lighting. Roof light, ignition warning light. Twin windscreen wipers. Two sun visors fitted.

**Weight:** (excluding extra equipment): Dry  $23\frac{1}{2}$  cwt. (1195 kg.). Complete with fuel, tools, oil and water, 25 cwt. (1272 kg.).

**Petrol consumption:** 22/24 m.p.g. (12.5–11.8 litres per 100 km.).

**EXTRAS:** Radio. Heater. Painted dark blue or grey. Tilt with lashing hooks and ropes.

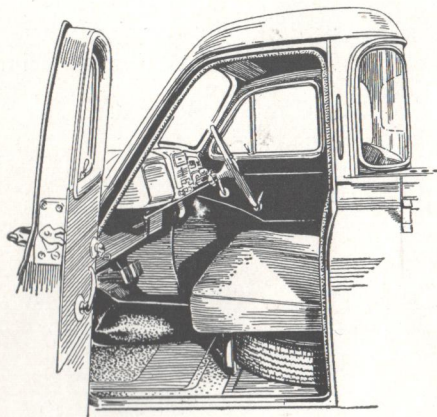

The driver's cab is roomy and comfortable. The spare wheel is accessible beneath the hinged passenger seat.

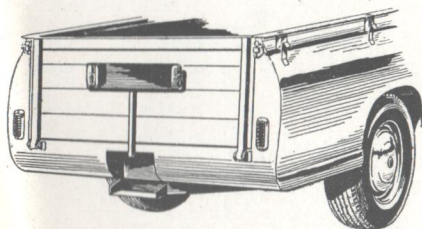

Shown here is the built-in bracket at the rear to take a towing attachment.

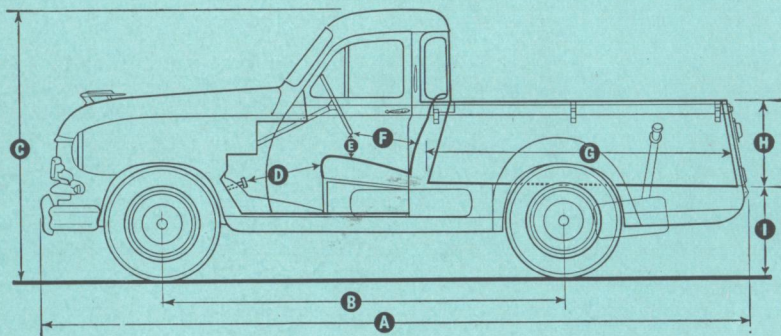

A	..	13 ft. 8½ ins. (4174 mm.)	H	..	20½ ins. (520 mm.)
B	..	7 ft. 10 ins. (2388 mm.)	I	..	25½ ins. (648 mm.)
C	..	64 ins. (1626 mm.)	J	..	5 ft. 9 ins. (1753 mm.)
D	..	17¾ ins. (451 mm.)	K	..	54½ ins. (1385 mm.)
E	..	5½ ins. (139 mm.)	L	..	42½ ins. (1079 mm.)
F	..	12½ ins. (317 mm.)	M	..	63 ins. (1600 mm.)
G	..	72 ins. (1830 mm.)			

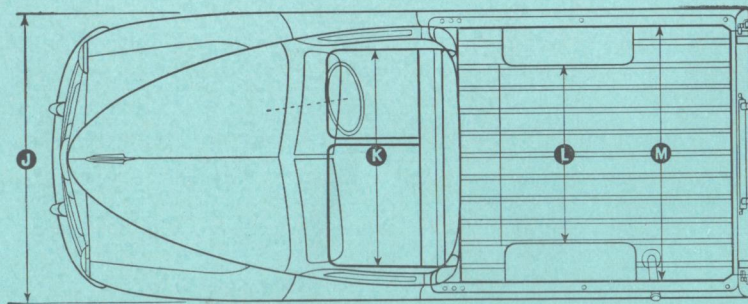



# Engine and chassis details for both models

*The powerful  
two-litre engine*

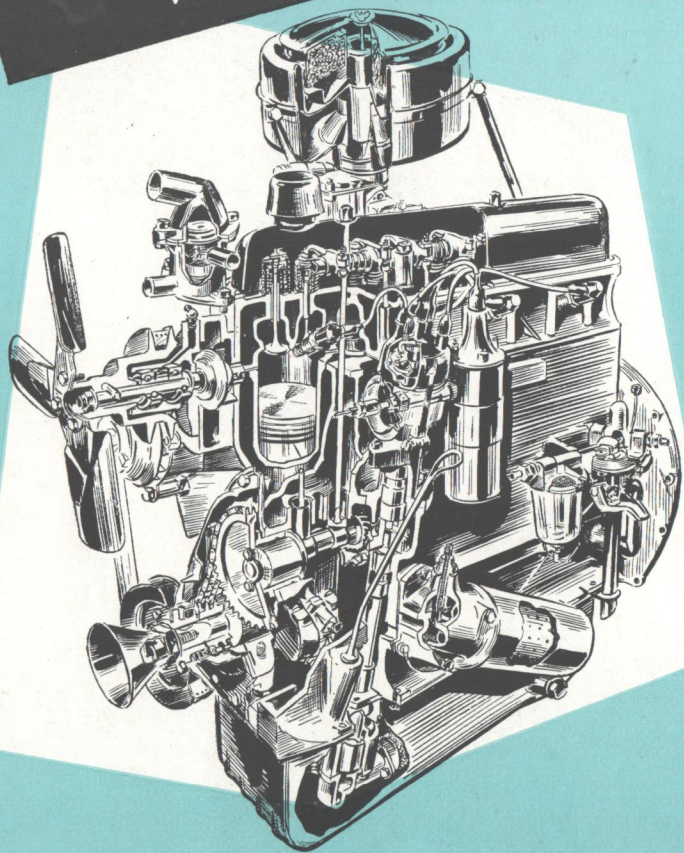

Cutaway view of the Standard Vanguard 2-litre engine  
as fitted to the Standard Commercial Vehicles.

## ENGINE AND CHASSIS DETAILS

Four cylinders, 85 mm. bore—92 mm. stroke. Capacity 2088 c.c. (two litre). Compression ratio 7-1. Replaceable cylinder sleeves, fitted in direct contact with cooling water. Three-bearing crankshaft. Overhead valves, push rod operation. Thermostatically controlled pump cooling system. Mechanically operated fuel pump. Down-draught carburettor. Air cleaner and silencer (oil bath type for export). Thermostatically controlled hot spot for quick warming.

**Clutch:** Borg and Beck 9 in. diameter single dry plate. Hydraulically operated. Ball thrust bearing.

**Gearbox:** Three forward ratios and reverse. Remote control gear change on steering column; lever pointing towards centre of car in both right- and left-hand models.

**Suspension:** Coil springs for independent suspension at front, long semi-elliptic rear springs specially designed.

**Brakes:** Lockheed Hydraulic.

**Steering:** Can be had with either right- or left-hand drive.

**Electrical Equipment:** 12 volt, 51 amp/hr. battery under bonnet. Headlamps, parking lamps, tail lamps, stop and reverse lights. Concealed Windtone horns.

**Petrol Tank:** 15 galls.

**Tyre Size:** 600-16 ins.

**Ground Clearance:** 8 ins. (203 mm.).

**Diesel Engine:** Separate specification available on request.



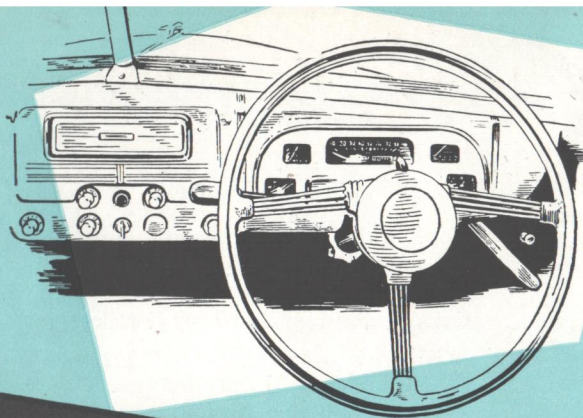

Facia panel with  
easy-to-read instruments.

*A chassis, fully framed and rigid!*

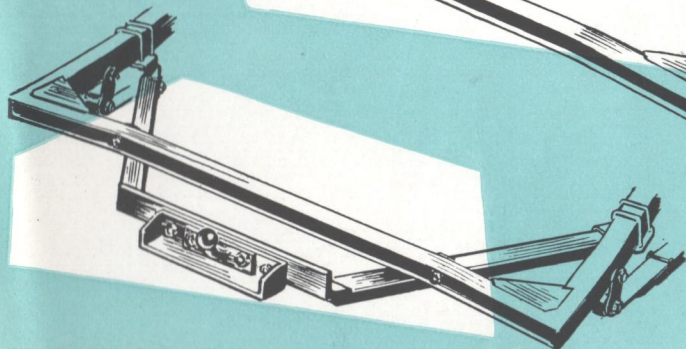
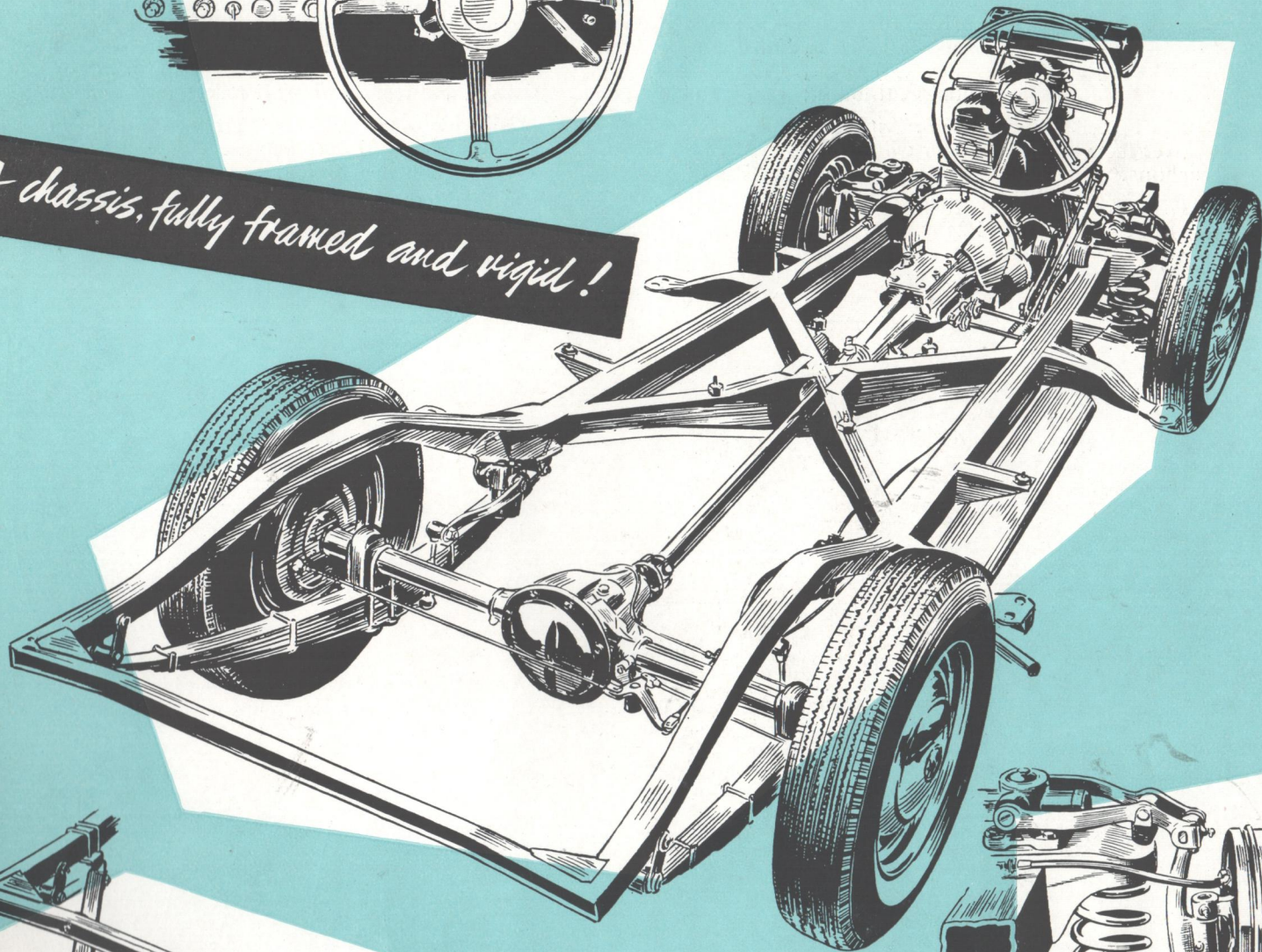

Details of the built-in bracket on the Pick-up, at the rear of the chassis, to which towing attachment can be fixed.

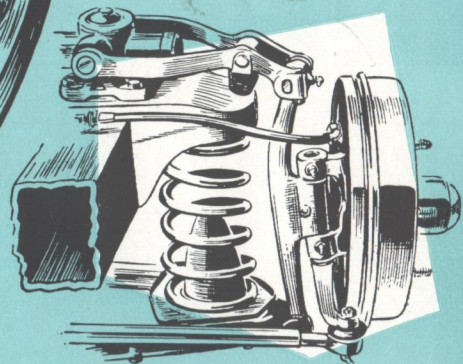

Independent front wheel suspension  
with Lockheed Hydraulic Brakes.



# The Van with style and stamina

**BODY:** Van type, two passenger doors with two goods entrance doors at rear. Finished in primer. Adjustable bucket-type driver's seat and removable bucket-type passenger's seat. Payload capacity 12 cwt. (600 kg.). Cubic capacity (excluding space beside driver) 105 cu. ft. (3 cu. m.). Other features include anti-draught ventilation by hinged deflector lights in front doors. Window winders to both doors. Locks to all doors and fuel filler cap. One-piece counterbalanced bonnet with lock-release control operated from inside body. Self-cancelling trafficators controlled from centre of steering wheel. Substantial matt finish chromium plated bumpers at front and rear. Twin rear reflectors.

**EQUIPMENT INCLUDES:** Triplex toughened safety glass fitted to all windows. Instruments grouped in front of driver include: speedometer with trip, ammeter, fuel, water temperature and oil pressure gauges. Concealed fascia lighting. Roof light, ignition warning light. Twin windscreen wipers. Two sun visors fitted.

**Weight** (excluding extra equipment): Dry  $23\frac{1}{4}$  cwt. (1182 kg.). Complete with fuel, tools, oil and water,  $24\frac{3}{4}$  cwt. (1258 kg.).

**Petrol consumption:** 22/24 m.p.g. (12.5–11.8 litres per 100 km.).

**EXTRAS:** Bench type seat. Radio. Heater. Painted dark blue or grey.

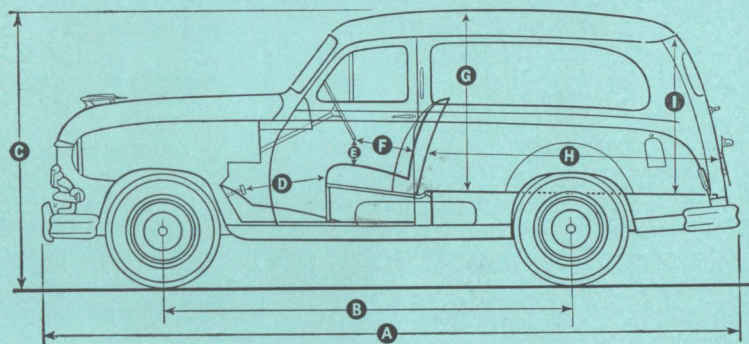

A ..	13 ft. 7 ins. (4146 mm.)	H (Bench Type)	$62\frac{1}{2}$ ins. (1587 mm.)
B ..	7 ft. 10 ins. (2388 mm.)	(Bucket Seat)	65 ins. (1651 mm.)
C ..	64½ ins. (1639 mm.)	I ..	34½ ins. (875 mm.)
D ..	17½ ins. (445 mm.)	J ..	5 ft. 9 ins. (1755 mm.)
E ..	5½ ins. (139 mm.)	K ..	67 ins. (1701 mm.)
F ..	10½ ins. (266 mm.)	L ..	42½ ins. (1079 mm.)
G ..	40½ ins. (1029 mm.)	M ..	46 ins. (1168 mm.)
Loading Height ..		25½ ins. (648 mm.)	

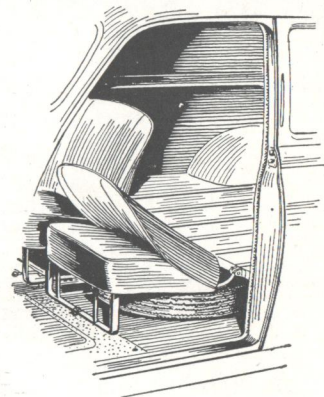
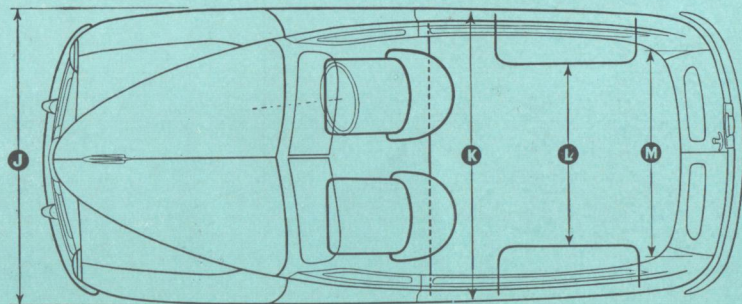

The spare wheel is accommodated beneath the passenger seat. The seat lifts up to give access to the wheel when required.

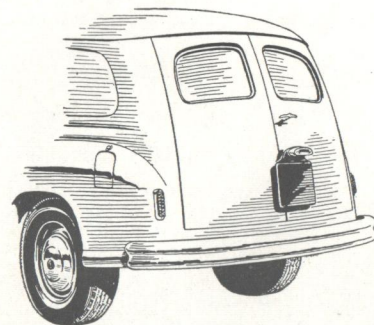

Showing the rear doors of the van closed.



# The Standard 12 cwt Delivery Van

## HANDSOME

The clean, handsome lines of the Standard Delivery Van will be a worthy salesman for your business, promoting goodwill and adding prestige to your name.

## POWERFUL

Fitted with the same 2-litre engine as the famous Standard Vanguard Saloon, the 12 cwt. Delivery Van can tackle every kind of gradient smoothly and easily, and will maintain a high performance under a variety of conditions.

## ROOMY

The roomy interior of the Standard Delivery Van has a cubic capacity of 105 cu. ft. (3 cu. m.). With the passenger seat removed a total capacity of 125 cu. ft. (3.5 cu. m.) is available. The driver's compartment is arranged with saloon car comfort with adjustable bucket type seats (bench type seat can be fitted as extra if required).

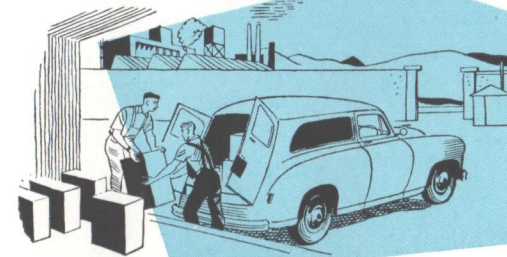
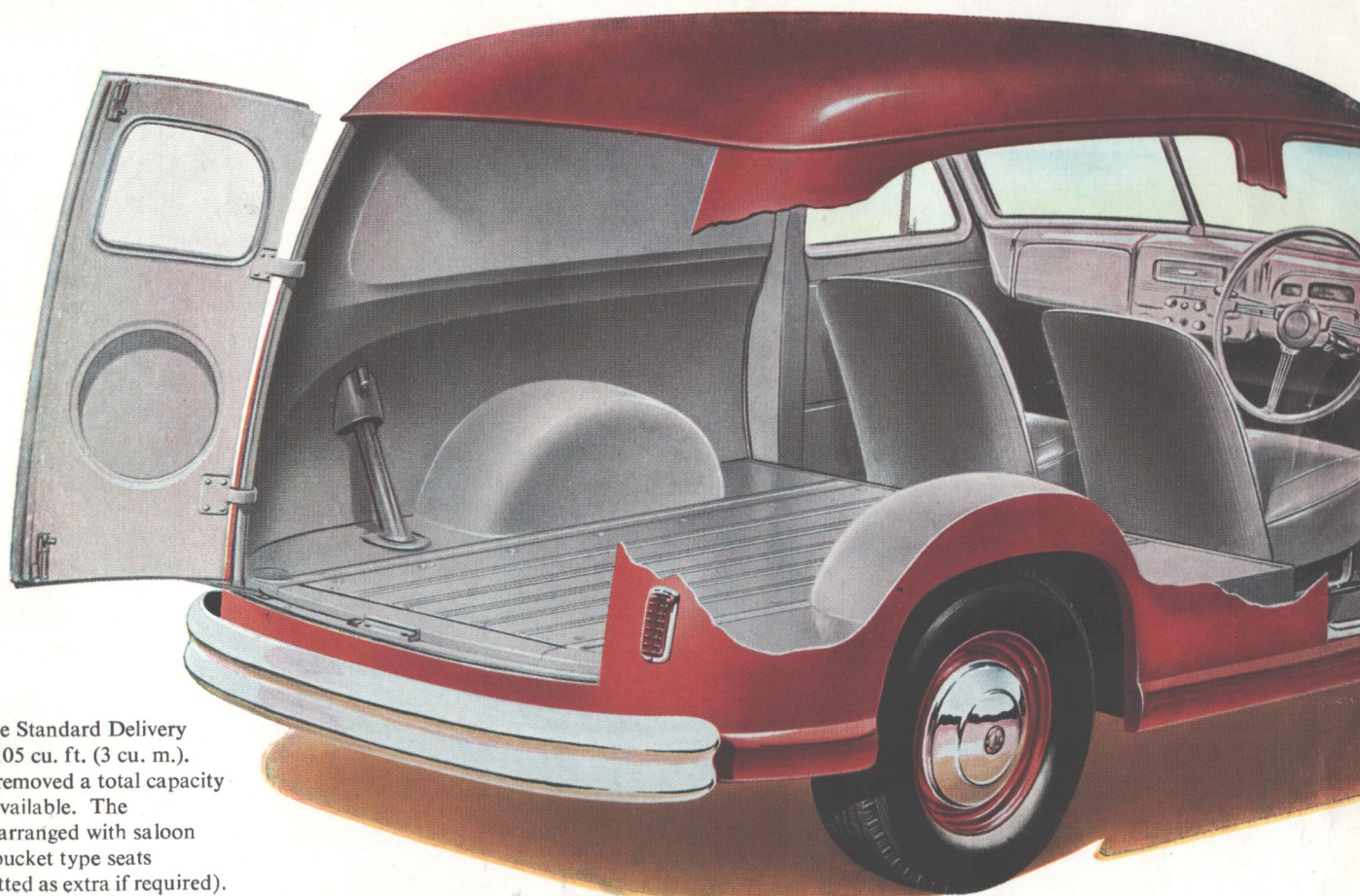



0007

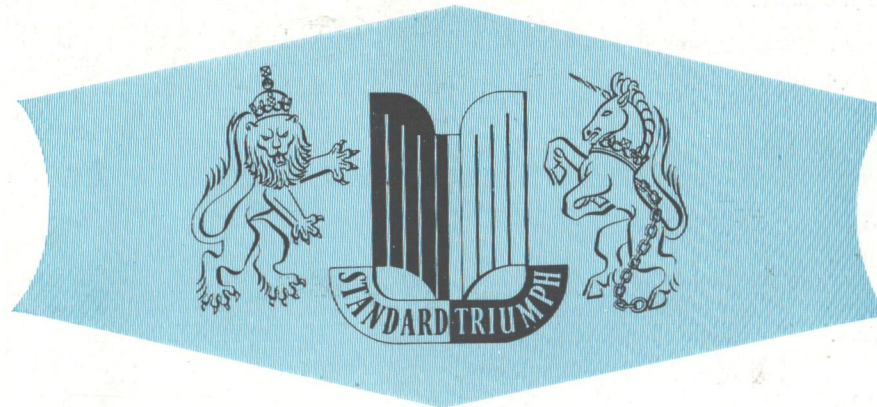

#### CONDITIONS OF SALE

*The goods manufactured by The Standard Motor Company Limited are supplied with an express warranty which excludes all warranties, conditions and liabilities whatsoever implied by Common Law, Statute or otherwise. The Company reserves the right to vary the list prices at any time and all goods are invoiced at the prices current on day of delivery, ex works. The Company reserves the right on the sale of any vehicle to make before delivery without notice any alterations to or departure from the specification, design or equipment detailed in its various publications in which every precaution has been taken to ensure accuracy, but the Company accepts no liability for errors or omissions.*

**THE STANDARD MOTOR COMPANY LIMITED, COVENTRY, ENGLAND**