

The finest

WOLSELEYS

of all....

the finest **WOLSELEYS** of all...the

Since motoring began the name Wolseley has identified a progression of cars a remarkable number of which remain memorably significant to the student of design. Today Wolseley engineering and Farina styling combine to produce what are undoubtedly the finest Wolseleys of all.

Few cars have ever made their début with more assurance of success. Never before have luxury and performance been blended so generously for such moderate outlay.

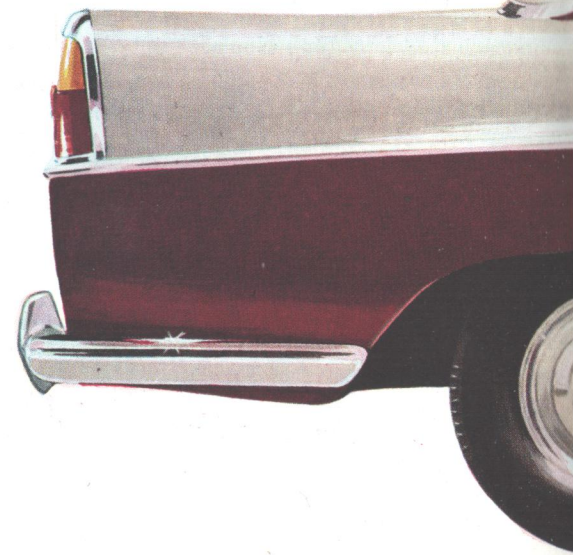

5-99



Style, performance and luxury...

Functional efficiency is thematic of the **Wolseley 6-99** styling concept. The design form itself stems from a combination of features of practical advantage. Within realistic overall dimensions generous accommodation is provided for six adults, their luggage, and personal impedimenta. Weight masses are sensibly located, to the betterment of handling and riding comfort. Forward visibility is aided by the wide, wrap-round screen and manoeuvring in reverse is made easy by the provision of a full-width, curved rear window through which the extremities of the rear wings are visible as markers for close parking.

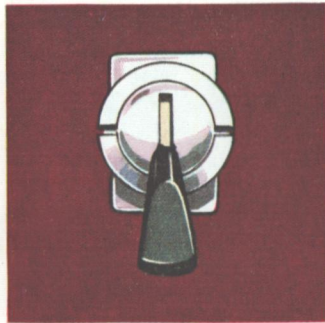

The fascia is finished in American burr walnut veneer, a rare and specially selected wood. The fascia top is soft-trimmed and padded. On the passenger's side a large glovebox, with locking lid, is provided. Large instruments are disposed either side of the steering-column and are clearly visible through the open segment of the dished-centre steering-wheel. For night driving the instruments are illuminated by the 'black light' system. Toggle switches, with a firm, definite action, are employed for road lights and the two-speed wipers. Traffic signal lights are self-cancelling and a warning light is incorporated in the actuating lever.

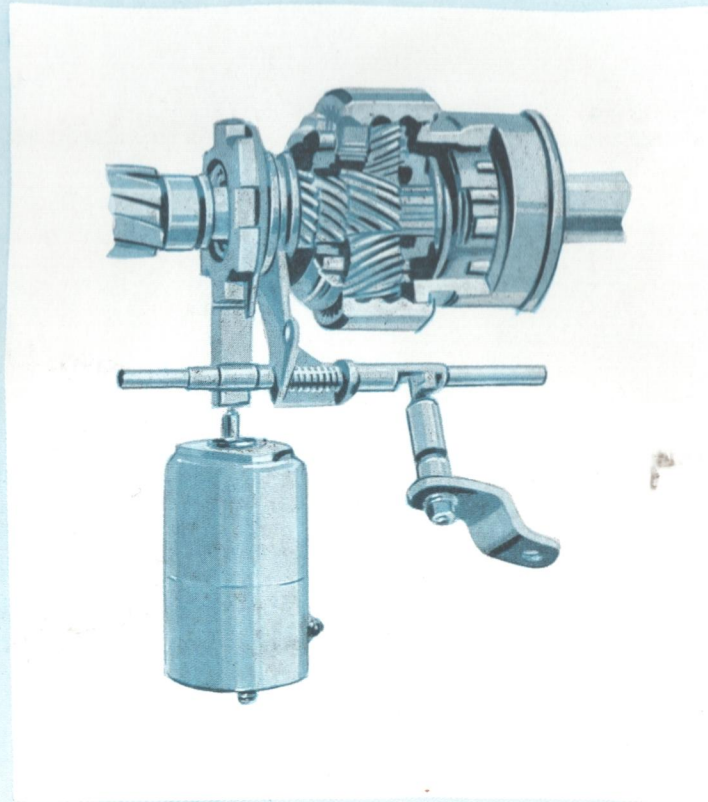
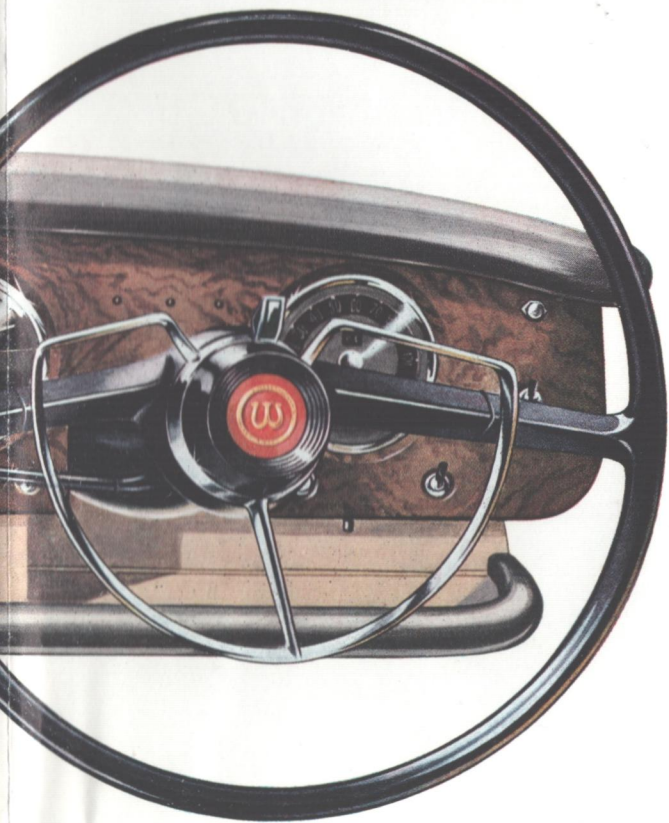

FIVE FORWARD GEAR RATIOS

For those who enjoy driving with a manually operated gearbox there is, in the **6-99**, an interesting innovation in transmission systems. Within a normal three-speed gearbox, with synchromesh on all three gears, an overdrive gear train can, by the operation of a push-pull control, be brought into operation with either of the two upper gear ratios. This, in effect, provides gear ratios first, second, and top plus a high second and a high top—five ratios in all. Drive to the gearbox is transmitted via an extra-large-diameter clutch with hydraulic actuation. The provision of five forward ratios has obvious advantages in that just the right ratio can be selected to suit prevailing conditions, giving smooth running and take-up at slow speeds, extra-rapid acceleration at higher speeds, or improved economy for fast cruising. Automatic transmission is also available.

the WOLSELEY

Headlamps are cowled against up glare and the beams dip and rise. Long-range driving lamps are flush-mounted and may be used at all times to suit driving conditions. Signal lights are incorporated in the separate sidelights; warning light for flashing signals is brighter by day than by night.

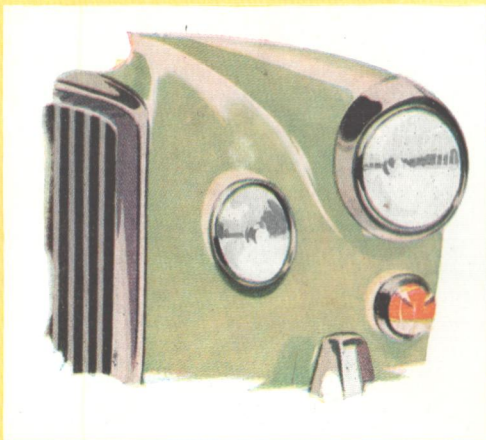

'Zero torque' safety locks with press-button catches are provided on all doors. In operation they are really quiet, and little more effort is required to close the doors than in shutting up a cocktail cabinet. The front doors can be locked both from the inside and from the outside.

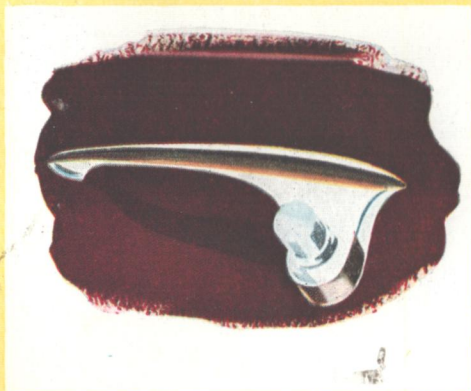

DISC BRAKES WHERE THEY ARE NEEDED

The front brakes are Lockheed hydraulic disc type, enormously powerful, positive in action, and fade-free. The large rear brakes, 10 in. by 3 in. (25.4 cm. by 7.6 cm.), are of the drum type. The entire system is vacuum servo assisted. The open disc brakes provide 60 per cent. or more of the retarding effort required for rapid deceleration from high speeds. The handbrake is conveniently placed on the floor between the seat and the driver's door.

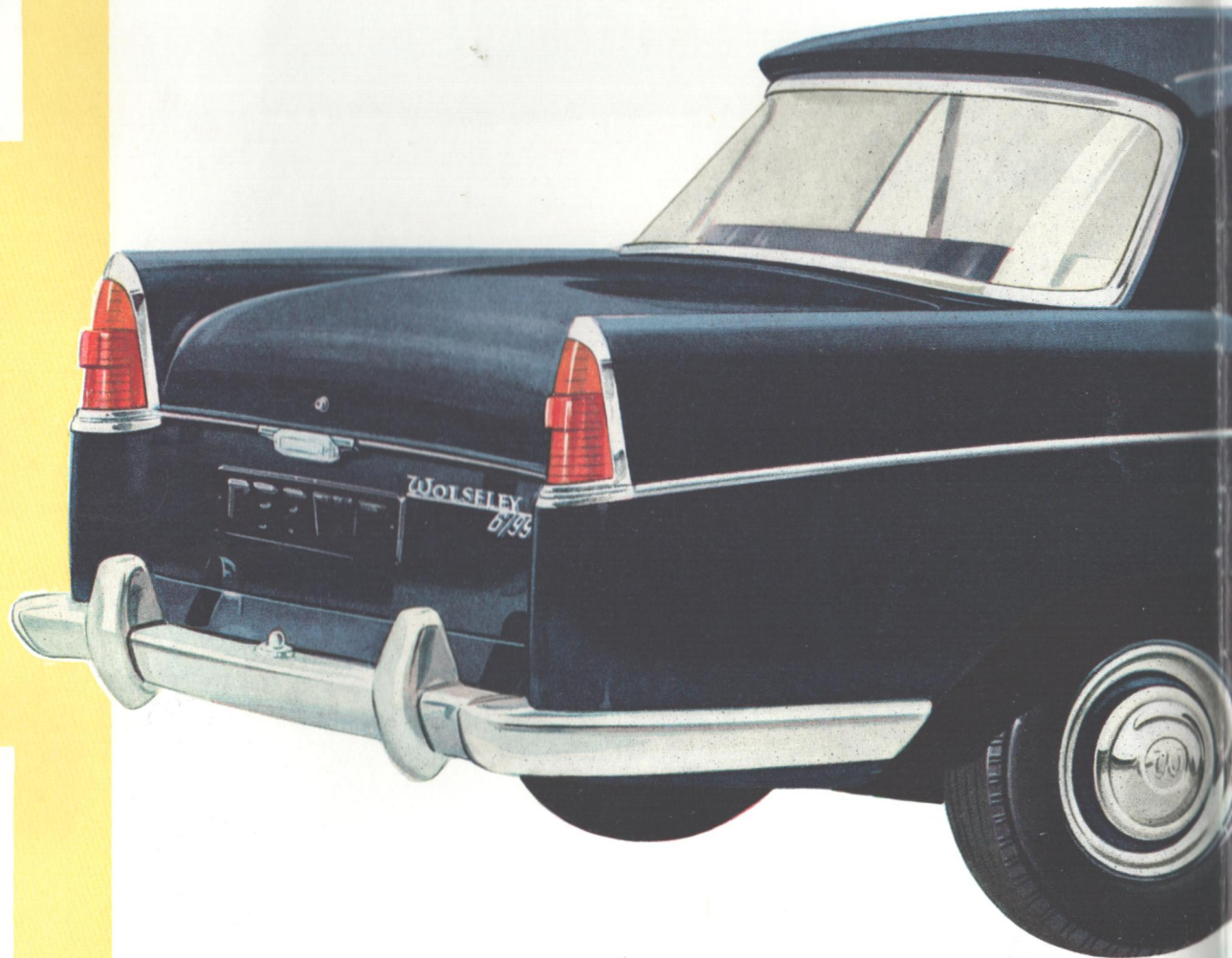
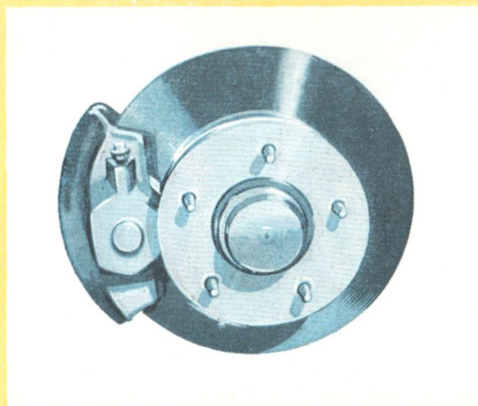

6-99 combines them all



The 6-99 is available in a wide variety of exterior and interior colour schemes. There is a choice of six attractive single colours and six duotone finishes. The all-steel body and chassis unit is treated for protection against rust, and the paintwork is of an extremely high quality, both in appearance and for durability.

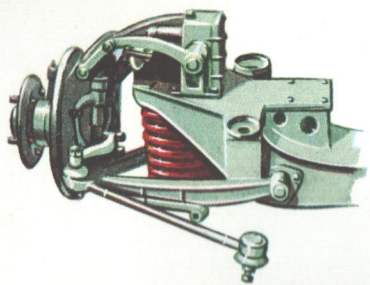

Particularly robust in construction is the independent front suspension system which employs wishbones and coil springs controlled by hydraulic lever-type shock absorbers. The entire suspension assembly is insulated against road wheel noise by rubber mountings.



Seat springing is phased in sympathy with the body suspension, and springs in the seat backs together with all-Dunlopillo seat cushions and generously padded edge rolls contribute to outstanding riding comfort. Combined door-pulls and arm-rests are fitted to all but the driver's door. Individual arm-rests fold away in the front seat back when three seats are required. Likewise, a wide, padded centre arm-rest in the rear compartment folds flush with the seat back. Hinged quarter-lights are fitted to front and rear doors and handsome polished wood door cappings match the fascia. Deep-pile carpets and fine English leather are included in the luxury specification.

The exceptionally wide boot is shaped to ensure that every inch is really usable luggage space. The boot lid is counterbalanced and operated by a press-button. Access to the spare wheel, housed beneath the boot floor, may be gained without disturbing luggage. The 6-99, when fitted with a Wolseley-approved towing attachment, is ideally suited to the needs of the caravan owner. Wolseley Dealers will give full details.

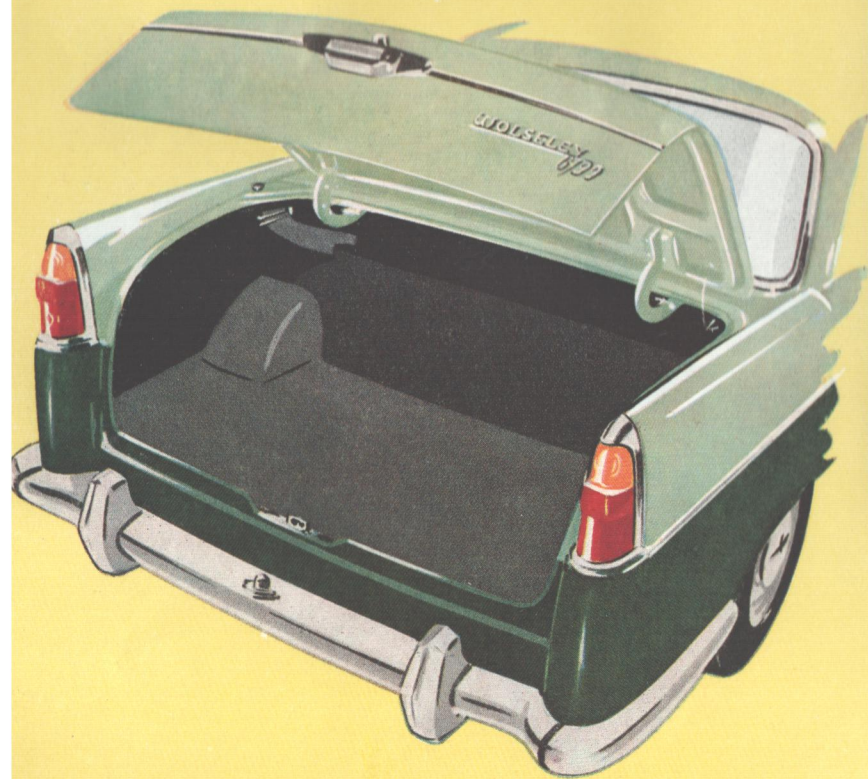

STEPPED-UP POWER

Development of Wolseley six-cylinder o.h.v. power units reaches the highest level of efficiency with reliability in the new 2.9-litre engine of the 6-99. This, in conjunction with a modest overall car weight and favourable streamlining, ensures an impressive 'Motor Road' speed potential. Twin S.U. carburetters, breathing through a large oil bath air cleaner, and excellent manifolding and combustion chamber shape combine to produce a power curve which is characteristic of a really satisfying all-round performance in the larger passenger car.

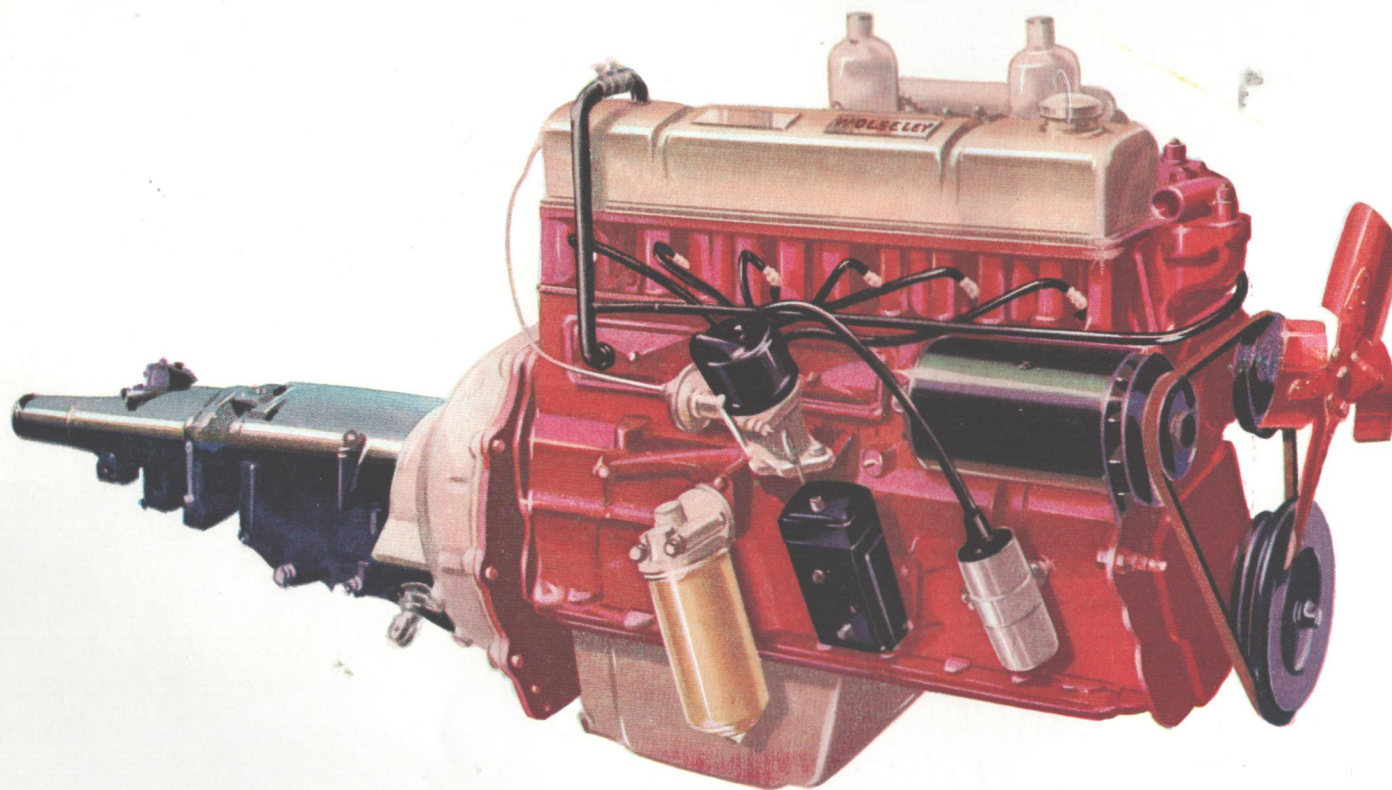

BUY WISELY... BUY WOLSELEY

- ★ Engineered by Wolseley for luxury and performance
- ★ Styled by Farina for elegance of body line
- ★ New 2.9-litre overhead-valve six-cylinder engine
- ★ Disc-type front brakes for increased safety
- ★ Extra-comfortable seating with all-Dunlopillo seat cushions for outstanding riding comfort
- ★ Full luxury equipment includes handsome polished wood door cappings and deep-pile carpet
- ★ Twelve months' warranty and backed by B.M.C. Service

No other cars b
and perfor

★ **AUTOMATIC TRANSMISSION**

The Borg-Warner fully automatic transmission system is available a system incorporates a holding device for the intermediate ratio; susta may therefore be used in that gear without an automatic upwar the 'hold' is put out of commission the system returns to full auto

blend luxury

performance with such a modest cost

The **WOLSELEY** *6-99*

*with manually operated gearbox
or *fully automatic transmission*

BUY WISELY... BUY WOLSELEY

at extra cost. The
sustained acceleration
ward change. When
automatic operation.

SPECIFICATION

ENGINE: Six cylinders; bore 83.34 mm. (3.281 in.), stroke 88.9 mm. (3.5 in.); cubic capacity 2912 c.c. (177.7 cu. in.); compression ratio 8.23 : 1 or 7.20 : 1 for certain Export markets. Developing 112 b.h.p. at 4,750 r.p.m. or 109 b.h.p. at 4,750 r.p.m. with low-compression engine. Overhead valves operated by push-rods from 4-bearing camshaft. Renewable-element external full-flow oil filter.

COOLING: By pressurized system assisted by impeller pump and fan. Circulation thermostatically controlled.

IGNITION: Battery and coil. Automatic advance and retard with centrifugal and vacuum control.

CARBURATION: Twin S.U. type H4 automatic carburettors with oil bath air cleaner and silencer. Twin rear-mounted S.U. type PD electric fuel pumps. 16-gallon (73-litre, 19.2-U.S.-gallon) fuel tank. Concealed fuel filler fitted with lock.

TRANSMISSION: Borg & Beck single-plate dry clutch with hydraulic actuation. Three-speed gearbox with synchromesh on all gears and fitted with overdrive. Overall gear ratios (not in overdrive), first 12.09, second 6.44, top 3.9, and reverse 11.73 : 1, overdrive ratio .7 : 1. Gear change lever mounted on steering-column. Axle ratio 3.9 : 1.

BRAKES: Lockheed servo-assisted hydraulic braking system employing discs at the front and 10-in. (25.4-cm.) drums at the rear. Servo unit mounted in engine compartment. Hand brake mounted on the floor at the driver's side.

BODY AND CHASSIS UNIT: Mono-construction 4-door saloon body. Large wrap-round bumpers front and rear with over-riders. Deep, well-sprung upholstery with foam-rubber seat cushions. Large luggage boot 18 cu. ft. (.51 m.³) capacity, with counterbalanced lid. Boot lid with lock.

SUSPENSION: Independent front suspension by coil springs and wishbones, hydraulic piston-type dampers with arms forming upper suspension link. Rear suspension by semi-elliptic, rubber-mounted springs and lever-type hydraulic dampers.

WHEELS AND TYRES: Ventilated disc wheels with 5-stud fixing and fitted with rimbellishers. Dunlop 7.00—14 tubeless tyres. Spare wheel housed in special carrier below luggage boot.

STEERING: Cam and lever steering gearbox, ratio 21 : 1. Two-spoke safety-type steering-wheel with semi-circular horn ring. Turning circle 40 ft. (12.192 m.). Track—front 4 ft. 5 $\frac{1}{8}$ in. (1.366 m.), rear 4 ft. 5 $\frac{1}{2}$ in. (1.352 m.). Left-hand-drive not available in the United Kingdom.

ELECTRICAL EQUIPMENT: High-output dynamo with compensated voltage control. 12-volt 58-amp.-hour battery (at 20-hour rate); double dipping headlamps; foot dipping switch;

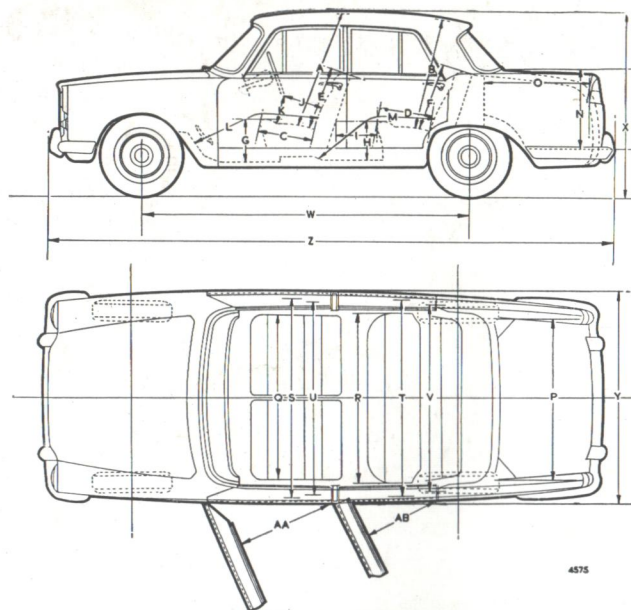

BODY DIMENSIONS

AA 3' 0 $\frac{1}{2}$ " (93 cm.)	AB 2' 0 $\frac{1}{2}$ " (63 cm.)	A 3' 0 $\frac{1}{2}$ " (93 cm.)	B 2' 10 $\frac{1}{2}$ " (87 cm.)
C 1' 7 $\frac{1}{2}$ " (49 cm.)	D 1' 7 $\frac{1}{2}$ " (49 cm.)	E 1' 9 $\frac{1}{2}$ " (55 cm.)	F 1' 11" (58 cm.)
G 1' 3" (38 cm.)	H 1' 4 $\frac{1}{2}$ " (42 cm.)	I 11" (28 cm.)	J 1' 1 $\frac{1}{2}$ " (34 cm.)
K 5" (13 cm.)	L 3' 8 $\frac{1}{2}$ " (113 cm.)	M 3' 9" (114 cm.)	N 1' 7 $\frac{1}{2}$ " (49 cm.)
O 2' 7" (78 cm.)	P 5' 0 $\frac{1}{2}$ " (153 cm.)	Q 4' 7" (140 cm.)	R 4' 9" (145 cm.)
S 5' 0 $\frac{1}{2}$ " (153 cm.)	T 4' 11" (150 cm.)	U 4' 9 $\frac{1}{2}$ " (146 cm.)	V 4' 7 $\frac{1}{2}$ " (141 cm.)
W 9' (2.74 m.)	X 5' (1.52 m.)	Y 5' 8 $\frac{1}{2}$ " (1.74 m.)	Z 15' 8" (4.77 m.)

Unladen weight 30 $\frac{1}{2}$ cwt. (1549 kg.) approx.

The issue of this folder does not constitute an offer, and the right is reserved to alter prices and/or specifications at any time without notice. Sales are conditional upon Terms of Business, Warranties and Service arrangements issued by Wolseley Motors Limited, and/or Nuffield Exports Limited. For Prices see separate list.

separate sidelamps; twin stop and tail lamps and reflectors; reversing light with automatic switch; number-plate lamp; twin long-range driving lamps; 2-speed windshield wiper; twin wind-tone horns; flashing signal direction indicators; 2 interior lamps operated by automatic switches in front doors and individually; instrument panel lighting; warning lights for ignition, headlamp main beam, flashing signals, and brake servo system.

INSTRUMENTS: Speedometer with trip and total distance recorders; fuel gauge; oil pressure gauge; engine temperature indicator; electric clock; ammeter.

CONTROLS: Toggle-type switches controlling headlights and sidelights, 2-speed windshield wiper, driving lamps, panel lights, and heater blower; mixture control; cigar-lighter; combined ignition and starter switch.

VENTILATION: Winding windows and hinged ventilating panels to all doors; fresh-air circulation system; heating equipment with heat control and windshield-demisting ducts.

GENERAL EQUIPMENT: Safety glass all round; large wrap-round windshield and rear window; windshield-washing equipment; driving-mirror; pile carpets with underfelt; 4 ashtrays; 2 sun visors; door locks with fixed handles and push-button lock release; divided bench-type front seats with individual adjustment and twin folding arm-rests; folding centre arm-rest in rear seat; arm-rests on all passengers' doors; glovebox in fascia with locking lid; sponge-rubber protection rails above and below fascia; parcel trays below fascia and behind rear squab; provision for fitting H.M.V. radio.

OPTIONAL EXTRAS:

Radio; automatic transmission.

COLOURS

Single-colour schemes: Black with maroon upholstery and mushroom carpet or beige upholstery and green mottle carpet. Yukon Grey with maroon upholstery and mushroom carpet or blue upholstery and blue mottle carpet or green upholstery and green mottle carpet. Porcelain Green with beige or green upholstery and green mottle carpet. Whitehall Beige with maroon upholstery and mushroom carpet. Navy Blue with blue or beige upholstery and blue mottle carpet. Smoke Grey with blue upholstery and blue mottle carpet.

Duotone colour schemes: Yukon Grey and Birch Grey with maroon upholstery and mushroom carpet. Black and Birch Grey with maroon upholstery and mushroom carpet. Maroon and Whitehall Beige with maroon upholstery and mushroom carpet. Connaught Green and Porcelain Green with beige upholstery and green mottle carpet. Navy Blue and Smoke Grey with blue upholstery and blue mottle carpet. Clipper Blue and Smoke Grey with blue upholstery and blue mottle carpet.

WOLSELEY MOTORS LIMITED

Proprietors: MORRIS MOTORS LIMITED

Overseas Business:

NUFFIELD EXPORTS LIMITED

Proprietors: MORRIS MOTORS LIMITED

COWLEY • OXFORD • ENGLAND



1962