



104
PEUGEOT



Introducing the Peugeot 104— the five door family hatchback range.



Four great hatchbacks.
All with four doors plus a
large easy-to-open tailgate.
All with front wheel drive.
All with a high level of
comfort, performance and
roadholding.

And now there's a choice of four
engine sizes and five levels of trim.
The 954cc GL, 1124cc GR, 1219cc SR
which is also available with an
optional Custom Pack, and the sporty
1360cc S. All extremely well-
equipped, well-priced, practical *and*
economical.

The 5-door 104 models offer you
room for all the family and their
luggage. Excellent head and leg

room plus four wheel independent
suspension ensure the most
comfortable ride and relaxed
journeys.

Like all Peugeot cars, the 104 models
are built to the highest standards
by some of the most up-to-date
manufacturing machinery available.
We bench test every engine and
test every gearbox electronically
through every gear before assembling
the car. Every single completed car is
then track and workshop tested by
qualified technicians.

Only by superb engineering and our
meticulous attention to quality
control can we help ensure that every
car is safe, strong and reliable.



GL

954cc. 45 bhp at 6000 rpm. Maximum speed 84 mph (135 km/h). Boot capacity rear seat in use 9.6 cu ft (273 dm³). Boot capacity rear seat down 24.5 cu ft (697 dm³). Four doors plus tailgate. 5 seats.



GR

1124cc. 57 bhp at 6000 rpm. Maximum speed 91 mph (145 km/h). Boot capacity rear seat in use 9.6 cu ft (273 dm³). Boot capacity rear seat down 24.5 cu ft (697 dm³). Four doors plus tailgate. 5 seats.



SR

1219cc. 57 bhp at 5500 rpm. Maximum speed 91 mph (145 km/h). Boot capacity rear seat in use 9.6 cu ft (273 dm³). Boot capacity rear seat down 24.5 cu ft (697 dm³). Four doors plus tailgate. 5 seats. Available with Custom Pack including sunroof, tinted glass all round, laminated windscreen, electric front windows and radio console.



S

1360cc. 72 bhp at 6000 rpm. Maximum speed 99 mph (158 km/h). 0-62 mph (0-100 km/h): 14.0 seconds. Boot capacity rear seat in use 9.6 cu ft (273 dm³). Boot capacity rear seat down 24.5 cu ft (697 dm³). Four doors plus tailgate. 5 seats. Electric front windows, tinted glass all round, laminated windscreen and radio console are standard equipment.







GL

Powered by a lively 954cc engine, the 104 GL is a winning combination of room for five adults plus 24.5 cu ft* (697 dm³) for luggage space.

Being a truly practical car, its wide opening tailgate lifts easily on gas-filled struts, a simple one-handed operation – a fact you will more than appreciate when your other hand is carrying a heavy load! There's no awkward boot lip to hinder loading either and for extra room the rear seat folds forward to give you a massive load area.

Equipment is of the highest level for a car in its class. Reversing and rear fog light are fitted as standard as are adjustable headlights and heated rear window, two-speed wipers with electric washers, brake warning light, two-speed heater fan, front and rear ashtrays and padded sun visors with vanity mirrors. Inertia reel seat belts and childproof locks on the rear doors add to your comfort and safety. And there's even a parcel shelf covering the boot to shield your belongings safely from prying eyes.

*Useful space with rear seat folded.





GL

104 GL - the economical answer to practical motoring. It runs on 2-star petrol returning up to 47 mpg* (6L/100 km) and only requires main servicing every 10,000 miles (15,000 km) with an intermediate oil change and safety check every 5,000 miles (7,500 km).

You will appreciate the attention given to even the smallest detail throughout this car. For example, comfortable yet hard-wearing cloth upholstered seats designed to keep you warm in winter and cool in summer. The neat instrument cluster showing you all the information you require at a glance. And the oddments tray built into the dashboard giving you plenty of space for all your bits and pieces.

Rear seat passengers travel in style too. There's generous leg and head room, door mounted armrests and large wind-down windows to ensure good visibility and total control of fresh air ventilation.

*In accordance with official Government test procedures. For full statistics see inside back cover.







GR Distinguished from the GL by its more powerful 1124cc engine, black wrap-around bumpers and large headlights, the 104 GR offers added performance as well as that extra touch of luxury. Trip mileage recorder, day/night rear view mirror, cigarette lighter and illuminated heater controls are featured and there's even a quartz clock to keep you on time for those important appointments.

The front seats of the GR recline to offer the driver an ideal driving position and are upholstered in a very stylish tweed cloth. A sliding steel sunroof is available as an option to make the 104 GR an even more desirable car, especially in those warm summer months.

Please note that 104 GR models for the UK have tweed upholstery as shown on 104 SR models, and not plain cloth as illustrated below.









SR

The SR features the new 1219cc engine for smooth, powerful motoring. Around town, along meandering country lanes or motorway cruising, you will appreciate the responsiveness and flexibility of this car.

Carpets, tweed upholstery and head restraints give added luxury inside, and outside, protector strips save the SR from those minor yet annoying scrapes and grazes that all too often occur.



Custom Pack

Even more luxury is offered on the SR with Custom Pack, which features laminated windscreen, tinted glass all round, electrically operated front windows, sliding steel sunroof and radio console.

The 104 SR offers you the choice of more style, more power and more equipment with all the versatility of a hatchback.





S

The 104 S is the real performer of the Peugeot 104 range. With its sporty 1360cc twin choke carburettor engine it develops 72 bhp at 6000 rpm and has a top speed of 99 mph (158 km/h) with a 0-62 mph (0-100 km/h) time of just 14 seconds.

The 104 S is equipped to perform, but safely: laminated windscreen, inertia reel seat belts, halogen headlamps and a dual circuit servo-assisted braking system with discs at the front and drums at the rear for safe, sure stopping power. To ensure excellent roadholding and safe cornering the 104 S is fitted with front and rear anti-roll bars.

The 104 S is also equipped to perform in style. The front seats have adjustable head restraints, are fully reclinable and the thick, supportive padding is upholstered in black fabric that emphasises the car's stylish, sporting good looks. Standard equipment also includes electric front windows and radio console.

Distinguishable from the outside by its special wide alloy road wheels, matt black paintwork to the window surrounds and sills, it also features sporty stripes and tinted glass all round.

The spare wheel on the S is stowed deflated under the bonnet. A compressor is supplied to inflate the tyre quickly. The Peugeot 104 S—the ideal solution for the young family man or woman who enjoys spirited motoring but requires the practicality of a hatchback.



104 S

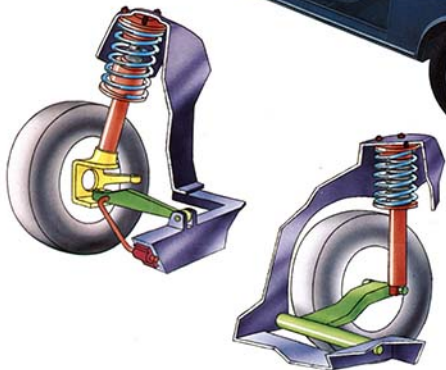

Sophisticated, independent suspension all round is shared by all models in the 104 5-door hatchback range. It is this design principle which enables passengers to ride in comfort and safety even when crossing the roughest surfaces. Handling is secure because each wheel remains in constant contact with the road, cushioning out the bumps and eliminating vibrations to the passenger compartment, so that you and your passengers arrive relaxed and fresh.

Mounted transversely, the engine is angled 72° to the rear. The space saved by adopting this engine layout can be utilised in the passenger compartment to offer more room for both passengers and their luggage, while keeping the overall length of the car to a minimum – just 11ft 10ins (3.62m).

Compact and manoeuvrable, the 104 has a turning circle of just 33ft (10.14m), making it ideal for nipping through town traffic.

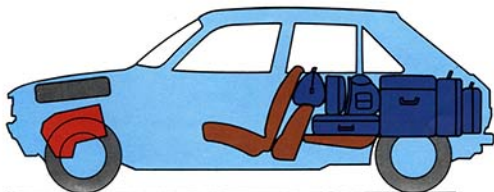

24.5 cuft (697 dm³)

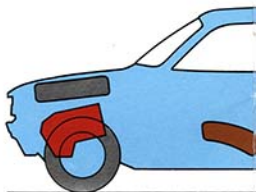

9.6 cuft

Boot volume



Engineered for long life using advanced technology and materials, the 104 is powered by a 4-cylinder in-line engine. Constructed of light aluminium alloy, the cylinder block is strong yet light, which therefore contributes to the 104's excellent fuel economy. Moreover, less weight on the driving wheels results in light, positive steering, even at low speeds, so that parking is always a simple task. Other features of this engine design include a high efficiency cross-flow cylinder head, a five bearing crankshaft for extra strength, and an overhead camshaft for smooth performance and greater efficiency.



(273 dm³)

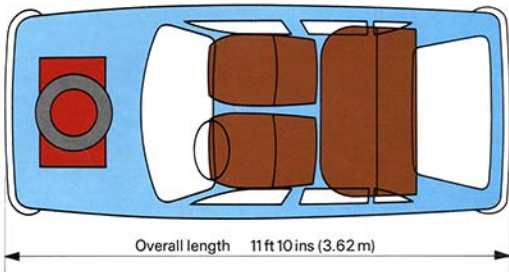

Overall length 11ft 10ins (3.62m)



104 Specification

Bodywork and General Information

Body

One piece steel bodyshell with electrophoretic anti-corrosion treatment. 5 seats. Folding rear bench seat.

Dimensions

Overall length:	GL	11 ft 8 in (3.58m)
	GR-SR-S	11 ft 10 in (3.62m)
Overall width:		5ft 0 in (1.52m)
Height unladen:		4ft 7 in (1.40m)
Height laden:		4ft 4 in (1.32m)
Wheelbase:		7ft 11 in (2.42m)
Boot volume:		9.6 cu ft (273 dm ³) with rear seat in use
		24.5 cu ft (697 dm ³) with rear seat folded

Fuel tank

Capacity: 8.8 gallons (40 litres)

Weight

Unladen weight:	GL	1719 lb (780kg)
	GR	1742 lb (790kg)
	SR	1763 lb (800kg)
	S	1818 lb (825kg)
Laden weight:	GL	2634 lb (1195kg)
	GR	2678 lb (1215kg)
	SR	2678 lb (1215kg)
	S	2734 lb (1240kg)

Towing

Maximum towing capacity:	GL	1763 lb (800kg)
	GR-SR-S	1984 lb (900kg)

Mechanical

Gearbox

Synchromesh gearbox with four forward speeds and reverse. Diaphragm type clutch with ball-bearing thrust operation.

Suspension

Independent suspension all round with coil springs and Peugeot double-action hydraulic telescopic shock absorbers. Front anti-roll bar on all models. Rear anti-roll bar on S.

Brakes

Front disc brakes, drums at rear. Mastervac power-assisted braking on S. Dual braking circuits with compensator.

Electrical system

12 volt electrical system with 500w alternator.

Tyres

GL-GR: 135 SR 13
 SR: 145 SR 13
 S: 165/70 SR 13
 Alloy road wheels on S. Spare wheel stowed under bonnet. Spare on S supplied deflated with compressor.

Steering

Rack and pinion steering. Overall turning circle: 31 ft 8 in (10.14m).

Engines

Four cylinder engine mounted transversely. Front wheel drive. Aluminium alloy cylinder block and head. Removable wet cylinder liners. Overhead camshaft. 5-bearing crankshaft. Electric cooling fan.

	GL	GR	SR	S
Fuel supply	single-choke carburettor	single-choke carburettor	single-choke carburettor	twin-choke carburettor
Bore x stroke	70 x 62	72 x 69	75 x 69	75 x 77
Capacity	954cc	1124cc	1219cc	1360cc
Compression ratio	8.8/1	9.2/1	9.2/1	9.3/1
Maximum power (DIN)	45 bhp at 6000 rpm	57 bhp at 6000 rpm	57 bhp at 5500 rpm	72 bhp at 6000 rpm
Maximum torque (DIN)	47 ft lbs (6.5 mkg) at 3000 rpm	59 ft lbs (8.2 mkg) at 3000 rpm	63 ft lbs (9.4 mkg) at 2750 rpm	79 ft lbs (10.9 mkg) at 3000 rpm
Maximum speed	84 mph (135 km/h)	91 mph (145 km/h)	91 mph (145 km/h)	99 mph (158 km/h)



Equipment

	GL	GR	SR	S		GL	GR	SR	S	
Heated rear screen	●	●	●	●	Quartz clock		●	●		
Rear fog lamp	●	●	●	●	Quartz digital clock				●	
Reversing light	●	●	●	●	Front head restraints				● ●	
Diagnostic test socket	●	●	●	●	Front carpets				● ●	
Cloth upholstery	●			●	Side protector strips				●	
Tweed upholstery		●	●		Sports steering wheel				●	
Two-speed windscreen wipers	●	●	●	●	Rev counter				●	
Electric windscreen washers	●	●	●	●	Side stripes				●	
Inertia reel front safety belts	●	●	●	●	Aluminium alloy wheels - 165/70 SR13 tyres				●	
Brake warning lamp: handbrake on/low fluid level	●	●	●	●	Matt black exterior trim				●	
Childproof locks on rear doors	●	●	●	●	Laminated windscreen				●	
Door armrests	●	●	●	●	Tinted glass				●	
Sun visors with vanity mirrors	●	●	●	●	Halogen headlamps				●	
Ashtrays	●	●	●	●	Servo-assisted brakes				●	
Two-speed heater/demister fan	●	●	●	●	Sunroof		○			
Rear parcel shelf	●	●	●	●	Electric front windows				●	
Day/night rear view mirror		●	●	●	Radio console				●	
Illuminated heater controls		●	●	●	Custom pack, including sunroof, tinted glass all round, laminated windscreen, electrically operated front windows and radio console					
Reclining front seats		●	●	●						○
Trip mileage recorder		●	●	●						
Cigarette lighter		●	●	●						

- Denotes standard equipment.
○ Denotes optional equipment.

Fuel Consumption*				
	GL	GR	SR	S
At a constant 56 mph (90 km/h)	47.1 mpg (6.1 L/100 km)	49.6 mpg (5.7 L/100 km)	47.1 mpg (6.0 L/100 km)	47.1 mpg (6.0 L/100 km)
At a constant 75 mph (120 km/h)	34.0 mpg (8.3 L/100 km)	37.7 mpg (7.5 L/100 km)	36.2 mpg (7.2 L/100 km)	35.3 mpg (8.0 L/100 km)
Simulated urban driving	32.1 mpg (8.8 L/100 km)	33.6 mpg (8.4 L/100 km)	32.8 mpg (8.6 L/100 km)	30.7 mpg (9.2 L/100 km)

*In accordance with official Government testing procedures.



PLEASE NOTE

Every endeavour has been made to ensure that the information contained in this brochure was accurate at the time of going to press. Peugeot Automobiles (UK) Ltd however, reserve the right while preserving the essential characteristics of the models described and illustrated in this brochure to introduce at any time modifications, changes of detail, equipment or accessories as may be considered necessary. The brochure will be updated from time to time but in order to avoid any misunderstanding any person interested in purchasing a vehicle should enquire of an authorised Peugeot dealer as to whether there have been any material alterations, since the date of the issue of this brochure.

1980



Finance & leasing facilities available from Peugeot Finance.
Anglo-French Finance Co. Ltd.

Take a test drive at your local Peugeot Dealer:

Peugeot Automobiles UK Ltd.,
333 Western Avenue, London W3 0RS.

PEUGEOT
World famous for strength.