

Previa



Whilst every effort is made to reproduce accurate information, we reserve the right to change specifications, equipment and availability without prior notice.

This brochure cannot be regarded as infallible, (some of the vehicles shown may not be to exact UK specification), and as such does not constitute an offer for sale of any particular vehicle or specification.

For the latest specification and availability we ask that you contact your local Toyota dealer.

For more information on any other Toyota models and the location of your nearest Toyota dealer, simply call: 0845 275 5555 (calls to Toyota may be monitored or recorded) or visit our web site: www.toyota.co.uk



Contents



Introduction

4



Performance

6



Comfort

8

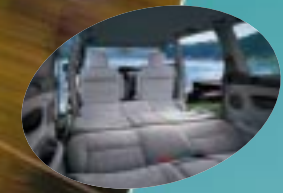

Interiors

10



Safety

14



Accessories

18



Specifications & Equipment

20



Peace of mind

24

The new Toyota Previa

Where adventure starts

The new Toyota Previa opens up a whole new world of adventure for you and your family.

With its futuristic looks and the superior performance of its advanced VVT-i engine, it combines outstanding levels of space and safety, with the added benefit of excellent fuel economy. And that means you can do more together as a family and explore further.

The Previa puts you in control with its unrivalled flexibility - the GS & GLS can seat up to eight - it gives you total flexibility, it gives you the freedom to do just what you want to do.



The Previa's all-new VVT-i engine combines class-leading performance with superb fuel economy - over 35 mpg* on the extra urban run for the manual version.

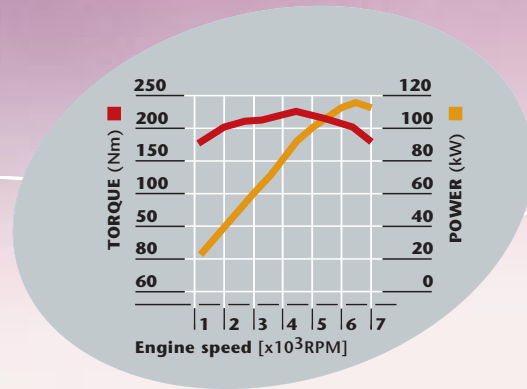

The most powerful four-cylinder engine in its class, the unit produces 154 bhp and 225 Nm of torque, ensuring the Previa responds quickly and safely to your driving requirements.



With Toyota's unique Optitron displays, important driver information is projected on to the instrument panel which cuts glare or reflection.

Stunning looks with performance to match

The Previa's performance is as striking as its good looks, thanks to an all-new 2.4 litre VVT-i petrol engine, developed under Toyota's highly advanced automotive engineering programme.

This four-cylinder unit, the most powerful in its class, propels the manual Previa to 62 mph in 11.1 seconds, yet enables it to achieve over 35 mpg*.

What's the secret? Variable Valve Timing - this automatically controls the timing and duration of inlet valve opening to ensure the engine runs at its most efficient whatever the circumstances.

Gear-shifting is smooth and easy with both the four-speed automatic gearbox and the five-speed manual version, while power-assisted steering affords precise control and manoeuvrability, especially when turning and parking.

Driveability is enhanced because of front-wheel drive and the Previa's new platform which provides excellent stability. Together, these features ensure secure road-holding, particularly when stopping and cornering.

In short, the Previa performs at its best - whenever you want it to and wherever you take it.

* Previa 93/116/EEC Combined 29.7MPG = 9.5L/100km, Urban 23.2MPG = 12.2L/100km, Extra Urban 35.3MPG = 8.0L/100km



Comfort and practicality all the way

Once in the driving seat, you'll immediately appreciate both the quality and lay-out of the Previa's superbly equipped cabin, with its luxurious cloth trim and excellent ergonomic and practical features.

The high driving position affords an uninterrupted view of the road ahead, while the Previa's large windows give first-rate visibility all round. Finding the perfect driving position couldn't be easier - simply adjust the seat height and steering wheel. And no matter which position you choose, you'll find all the controls within easy reach, so that you can concentrate on keeping your eyes on the road.

You can also adjust - and heat - both wing mirrors electrically and, with Toyota's unique Optitron displays, you can see vital information 'projected' on to the instrument panel, thereby minimising glare and reflection. Behind you, the family will also enjoy Previa levels of comfort and practicality, giving you complete peace of mind - especially on long journeys.

The Previa has 18 separate compartments in the dashboard and side panels, giving you ample storage space for all your personal effects.

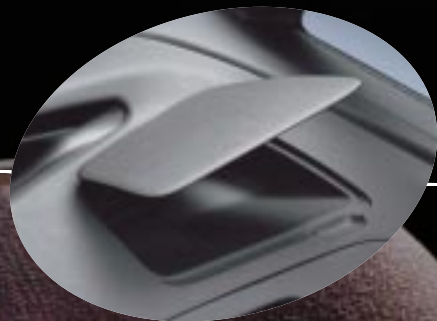

Long journeys in the GLS and CDX models are made even more relaxing by cruise control and front and rear air-conditioning, easily activated at the flick of a switch.



No more wrong turns - finding the best route to your destination couldn't be simpler with the Toyota Satellite Navigation System, an invaluable optional extra (standard on CDX).



The integrated audio system delivers superbly balanced sound through six speakers discreetly placed throughout the vehicle.



Interior not to UK specification

Travel in space

The Previa's interior space takes some beating. And that means great flexibility. So, whatever adventure you have in mind for the family, the Previa can handle it - easily!

You have a choice of five, six, seven or even eight seat configurations - with luggage space to match. Converting the Previa to your individual requirements couldn't be easier and takes no time at all.

For ease of access, there are wide sliding doors on each side. And, because of its exceptionally low floor height, the Previa offers the best head and leg room in its class. In addition, with the large rear door and its low lip, loading heavy, bulky items is no problem at all.



The Previa is so versatile. By removing or folding seats, you can create plenty of space to accommodate such items as bicycles, yet still leave room for all the family.



You can choose five, six, seven or eight seat configurations. So whatever your requirement, the Previa has the flexibility to meet it.



The large rear door and low boot lip make it easy to load all the family luggage in the cavernous boot area.

Interior not to UK specification



So relaxing, so enjoyable

The Previa is a truly relaxing experience. We've tried to think of everything to make each journey comfortable and enjoyable for every occupant.

The six-speaker audio system maximises sound balance throughout, while the air-conditioning and air-filter systems keep the cabin refreshingly cool.

Pleasure is further enriched by the Previa's quietness, due to thick carpet and rich upholstery, plus the vehicle's new platform, which improves stability and cuts vibration to a minimum.

Coupled with the wide range of standard practical features the Previa offers, it means every trip you and the family take together will be as smooth and comfortable as possible.

And if, for you, total contentment means a world on its own, why not opt for the 'privacy' glass offered on the Previa CDX?

So, wherever you go, whatever adventure you follow, the Previa will ensure your journey into the wide open spaces is as we designed it to be - restful and effortless for everyone.

Safety first and foremost

At Toyota, we recognise that whenever you take to the road with the family, you want to be assured of their safety. And that's exactly why we've designed the Previa with so many safety and security features.

Every model has computerised ABS braking, supported by EBD (Electronic Braking force Distribution), to prevent the wheels from locking and help the driver to retain steering control. A multi-reflector brake light on the roof spoiler gives ample warning to following drivers.

The body-shell is highly crash-resistant and there are side-impact beams in the side doors. Seat belts are standard throughout. The driver and front-seat passenger have three-point belts with pre-tensioners and force-limiters - and they also enjoy the added protection of SRS airbags.

With the addition of a first-class range of sophisticated security measures, including immobiliser and double-locking, the Previa gives you and your family all-round confidence.



The highly crash-resistant body-shell and energy-absorbing side-impact beams in the side doors provide excellent protection for all occupants in the event of an accident.



Driver and front-seat passenger enjoy the extra security of SRS airbags, in addition to three-point seat belts with pre-tensioners and force limiters.

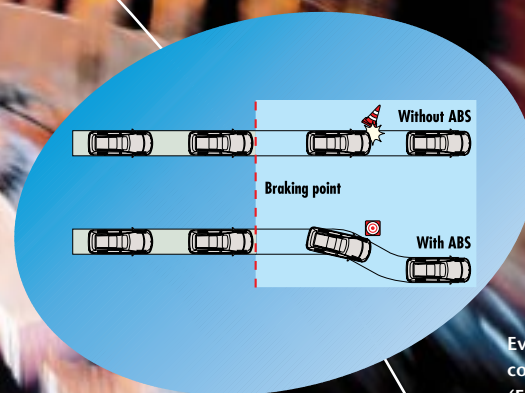

Every Previa is equipped with computerised ABS braking and EBD (Electronic Braking force Distribution) systems to prevent wheel-lock and retain steering control in emergency situations.

Easy Start

Finding the deposit doesn't have to be an obstacle to driving a new Previa.

Previas Easy Start, means you can be on the road after paying a low deposit that's no more than the equivalent of your first monthly payment.

At the end of the Previa Easy Start plan, you have three attractive choices:

- You can part exchange your Previa for a new model and use any money left over above the Guaranteed Future Value/Final Payment towards the deposit.
- You can continue to drive your Previa - simply pay the Guaranteed Future Value/Final Payment and the car becomes yours*
- You can return the car provided that you have not exceeded the agreed mileage and the car is in good repair. All you pay is a £25 fee and you return the car with no further charges.

*A £40 Option to Purchase fee is payable at the end of the agreement.

Easy Drive

This plan allows you to include most of your motoring costs for 2 or 3 years in a single payment each month and covers:

- The cost of your car on a 2 or 3 year Toyota Terms agreement
- A 2 or 3 year Toyota Easy Care servicing plan covering routine major and intermediate services.
- Extended membership of Club Toyota for 2 or 3 years. This covers Toyota EuroCare, RAC Homestart, Roadside Assistance and Vehicle Recovery in the UK and Europe*. It also includes a two day replacement loan car or onward transport when required. And, of course, you'll enjoy all the additional motoring, travel and leisure benefits that Club Toyota membership brings.
- As a further option you can also include the cost of 2 or 3 years car insurance from Toyota Insurance in your monthly payment. This offers you the additional convenience and reassurance of knowing that any claims will be managed by the Toyota Accident Service - with repairs carried out by an authorised Toyota bodyshop.

* Ask your Toyota dealer for details of the countries covered by Roadside recovery and Assistance.

Business Drive

Business Drive is a fully maintained contract hire package most suited to small business customers.

The package includes the following benefits:

- The cost of your car on a 2 or 3 year contract hire agreement
- Routine scheduled servicing (including routine servicing parts)
- Mechanical repairs required through fair wear and tear
- Replacement tyres
- Courtesy vehicle in the event of mechanical failure
- Renewal of road fund licence in 2nd and 3rd year
- RAC Cover/European Cover/Extended Club Toyota membership/Toyota EuroCare.
- An accident management service.

The Business Drive package clearly offers many customer benefits including reduced capital outlay, all-inclusive monthly rentals and no depreciation disposal or administration problems – everything is taken care of by Toyota Contact Hire.

Easy Care

A well maintained car not only provides better performance and greater safety, it also holds its value better too. That's an important consideration when it comes to changing your car in the future.

The Toyota Easy Care Plan ensures that your car receives the very best maintenance and servicing at all times, by allowing you to spread the payments over a ten month period. You'll find that Toyota Easy Care is a simple method for prepaying the following costs:

- Routine major services (including routine servicing, parts* and labour)
- Intermediate oil and filter services

* excludes any replacement parts additional to the service, such as brake pads, tyres, clutch etc.

Your Toyota Dealer can arrange cover by Toyota Easy Care for either 2 or 3 years and at annual mileage bands of between 10,000 and 40,000 miles. The Toyota Easy Care Plan represents excellent value for money and provides added peace of mind with your new Toyota.

Flexible Finance

These specific Previa Drive Plans may not suit your individual needs. Perhaps you prefer a more traditional method of financing your car. Whatever your requirements Toyota have a full range of finance options to offer you. Just discuss your personal requirements with your Toyota dealer who will be pleased to help.

Typical finance example

Previas GS Manual 8 seat 10,000 miles per year for 36 months (non-maintained)

| | |
|---|-------------------|
| Cash price on the road | £19,950.00 |
| 20% deposit/initial payment | £3,990.00 |
| 35 monthly payments | £375.00 |
| Guaranteed future value/final payment | £7,611.01 |
| Total amount payable[†] | £24,836.01 |
| APR | 14.5% |

[†]Includes £70 Credit Facility Fee (charged with the first payment) and £40 Option to Purchase Fee (charged with the final payment). Based on 10,000 miles per year on Toyota Terms. Additional mileage charged at 8.5p per mile inc. VAT. Written quotations available on request from Toyota Financial Services (UK) PLC. Indemnities may be required. All applications for credit are subject to acceptance. Prices and example are correct at time of going to print.

Previas
drive plans

Previa accessories

When you choose a Previa, you choose adventure and individuality.

But, with Toyota's wide range of quality accessories, you can make your Previa even more personal to reflect both your family's individual lifestyle and your own taste.

Above all, you can enhance the Previa's outstanding practical qualities so that, wherever you go and whatever you do, you are fully equipped to make every adventure more enjoyable and more memorable.

Previa accessories have been specifically designed to add to your comfort, convenience and style. They are genuine, Toyota components, made to exacting standards, that will not only make your life easier but also add value to your Previa.

Ask your Toyota dealer for the full range of Previa accessories.



Mud flaps

Mud flaps not only protect your Previa's bodywork from stone chippings and road dirt, they also reduce spray to other road-users.

Parking corner sensors

The high-tech way to avoid parking knocks and scratches. Ultrasonic sensors mounted on each rear corner are triggered when approaching a vehicle or other obstacles adjacent to vehicle corners.

Bumper protectors

Bumper scuffs are unsightly. Minimise impacts with this specially designed corner protector.

Towing hitch

For extra flexibility, you have a choice of tow bars, either fixed or detachable, both with wiring kits provided.

Roof racks

A purpose-made roof rack will enable you to carry all those extra items safely and securely, using one of the range of accessory holders available.

Rear mounted bike holder

Secure your cycles safely with purpose-made bike holders.

Cargo net

Loosely loaded items can get damaged or be a danger, so keep them firmly secure with a cargo net.

Seat storage bag

Provide extra stowage with a special storage bag that fits neatly over the front or second-row seats.

Cool box

For those lazy days of summer, make sure your food and drinks keep refreshingly chilled in a tailor-made cool box.



Gala 15" Alloy wheel

Make your Previa even more special with a choice of three distinctive alloy wheels.



Specifications

| Dimensions | GS Manual | GS, GLS & CDX Automatic |
|--|---|---|
| Overall length - mm (ins) | 4750 (187.0) | 4750 (187.0) |
| Overall width - mm (ins) | 1790 (70.5) | 1790 (70.5) |
| Overall height - mm (ins) | 1770 (69.7) | GS: 1770 (69.7); GLS/CDX: 1810 (71.3) |
| Wheel base - mm (ins) | 2900 (114.2) | 2900 (114.2) |
| Tread front - mm (ins) | 1545 (60.8) | 1545 (60.8) |
| Tread rear - mm (ins) | 1530 (60.2) | 1530 (60.2) |
| Interior length - mm (ins) | 3120 (122.8) | 7 seat: 3040 (119.7); 8 seat: 3120 (122.8) |
| Interior width - mm (ins) | 1560 (61.4) | 1560 (61.4) |
| Interior height - mm (ins) | 1265 (49.8) | 7 seat: 1255 (49.4); 8 seat: 1265 (49.8); 7 seat with sunroof: 1240 (48.8) |
| Overhang front - mm (ins) | 835 (32.9) | 835 (32.9) |
| Overhang rear - mm (ins) | 1015 (40.0) | 1015 (40.0) |
| *Luggage space (8 seat) (3rd row bench seat down) - mm (ins) | Front: 530 (20.9); Neutral: 440 (17.3); Rear: 280 (11.0) | Front: 530 (20.9); Neutral: 440 (17.3); Rear: 280 (11.0) |
| *Luggage space (8 seat) (3rd row bench seat tipped up) - mm (ins) | Front: 995 (39.2); Neutral: 940 (37.0); Rear: 695 (27.4) | Front: 995 (39.2); Neutral: 940 (37.0); Rear: 695 (27.4) |
| *Luggage space (7 seat) (3rd row detachable seat in) - mm (ins) | - | Front: 605 (23.8), Neutral: 545 (21.5) Rear: 485 (19.1) |
| *Luggage space (7 seat) (3rd detachable seat removed) - mm (ins) | - | Front: 1405 (55.3), Neutral: 1345 (52.9) Rear: 1285 (50.6) |
| Interior volume - cu ft (m ³) | 166 (4.7) | 166 (4.7) |
| Towing capacity - kg | 1600 with brake, 600 without | 1600 with brake, 600 without |

| Engine | GS Manual | GS, GLS & CDX Automatic |
|-------------------------------------|---------------------|-------------------------|
| Engine type | 16-Valve, DOHC | 16-Valve, DOHC |
| Bore x stroke - mm | 88.5 x 96.0 | 88.5 x 96.0 |
| Displacement - cm ³ | 2362 | 2362 |
| Compression ratio | 9.6 : 1 | 9.6 : 1 |
| Maximum output - KW/rpm (bhp/rpm) | 115/5600 (154/5600) | 115/5600 (154/5600) |
| Maximum torque - Nm/rpm (lb ft/rpm) | 225/4000 (166/4000) | 225/4000 (166/4000) |
| Battery - Volts/Amp hours | 12/36 | 12/36 |
| Alternator output - Watts | 1200 | 1200 |

| Performance | GS Manual | GS, GLS & CDX Automatic |
|-----------------------------|-----------|-------------------------|
| Maximum speed - km/h (mph) | 183 (114) | 179 (111) |
| Acceleration 0-62mph - secs | 11.1 | 12.5 |

| Fuel consumption | GS Manual | GS, GLS & CDX Automatic |
|---|-------------|-------------------------|
| Fuel tank capacity - litres (gallons) | 76 (16.7) | 76 (16.7) |
| Fuel economy (93/116/EEC) - l/100km (mpg) | Urban | Urban |
| | 12.2 (23.2) | 14.5 (19.5) |
| | Extra urban | Extra urban |
| | 8.0 (35.3) | 8.7 (32.5) |
| | Combined | Combined |
| | 9.5 (29.7) | 10.8 (26.2) |
| CO ² emissions - g/km | 228 | 259 |
| No. of turns to lock | 3.62 | 3.62 |

| Brakes | GS Manual | GS, GLS & CDX Automatic |
|--------|-----------------|-------------------------|
| Front | Ventilated disc | Ventilated disc |
| Rear | Disc | Disc |

| Suspension | GS Manual | GS, GLS & CDX Automatic |
|--------------------|-------------------------|-------------------------|
| Front | MacPherson strut system | MacPherson strut system |
| Rear | Torsion beam | Torsion beam |
| Steering gear type | Rack & Pinion | Rack & Pinion |

| Weights and cargo | GS Manual | GS, GLS & CDX Automatic |
|---------------------------|-----------|--|
| Kerb weight (total) (kg) | 1555-1695 | 7 seat 1555-1735 (3428-3825) 8 seat 1585-1725 (3494-3803) |
| Gross Vehicle Weight (kg) | 2370 | 7 seat/8 seat 2355 (5192) / 2400 (5291) |

| Tyres | GS Manual | GS, GLS & CDX Automatic |
|-----------|------------|-------------------------|
| Tyre size | 205/65 R15 | 205/65 R15 |

* Luggage space data measurement taken from seat cushion to back door trim

Colour & Trim

Drake Grey



Arctic white



Silver steel (m)



Henna red (m)



Ashdown green (m)



Carlo blue (m)



Moon steel (m)

(m) - Metallic paint

Equipment

| Safety | GS | GLS | CDX |
|--|----|-----|-----|
| Driver & front passenger airbags with hybrid inflators | ● | ● | ● |
| Electronically controlled ABS with electronic brake distribution logic (EBD) | ● | ● | ● |
| Electronic sensing front seatbelt pre-tensioners with force limiters | ● | ● | ● |
| Front 3-point seat-belts with Emergency Locking Retractor (ELR) | ● | ● | ● |
| 2nd and 3rd row outer seat 3-point seat-belts with ELR and ALR | ● | ● | ● |
| Seat integrated front seat-belt anchorage and support | ● | ● | ● |
| High mounted stop lamp (HMSL) | ● | ● | ● |
| De-coupling brake pedal mechanism | ● | ● | ● |
| Anti-trap on automatic up driver's window | ● | ● | ● |
| Energy absorbing, deformable and retracting steering column | ● | ● | ● |
| Pipe side-impact beams in side doors | ● | ● | ● |
| Front, rear and side energy absorbing crumple zones | ● | ● | ● |
| Front, side and rear head impact absorbing structure | ● | ● | ● |
| Auto cancel rear fog lamp | ● | ● | ● |

| Instruments and controls | GS | GLS | CDX |
|--|----|-----|-----|
| Tachometer | ● | ● | ● |
| Water temperature gauge | ● | ● | ● |
| Twin speed & variable intermittent front wash wiper control with mist function | ● | ● | ● |
| Intermittent & continual sweep rear wash wiper control | ● | ● | ● |
| Fuel gauge with low fuel warning | ● | ● | ● |
| Digital clock | ● | ● | ● |
| Electric headlamp levelling | ● | ● | ● |
| Instrument light dimmer | ● | ● | ● |
| Digital odometer/trip meter | ● | ● | ● |
| Engine management warning and fog lamp indicator lights | ● | ● | ● |

| Comfort and convenience | GS | GLS | CDX |
|--|----|-----|-----|
| Power assisted steering (PAS) | ● | ● | ● |
| Front and rear door mounted electric windows | ● | ● | ● |
| Driver's window electric one touch up and down with safety anti-trap | ● | ● | ● |
| Manual tilt front glass sunroof with shade | - | - | ● |
| Electric tilt/slide rear glass sunroof with shade | - | - | ● |
| Rear privacy glass | - | - | ● |
| Central locking with remote control and double locking | ● | ● | ● |
| Electric & heated exterior mirrors | ● | ● | ● |
| Stepless tilt adjustable steering column | ● | ● | ● |
| Remote front courtesy light operation | ● | ● | ● |
| Rear passenger door operated interior 'lights-on' function | ● | ● | ● |
| Driver and front passenger vanity mirrors | ● | ● | ● |
| Driver and front passenger seat mounted arm rests | ● | ● | ● |
| Illuminated ashtray | ● | ● | ● |
| Rear coat hooks | ● | ● | ● |
| Heated rear window | ● | ● | ● |
| Luggage load hooks in boot | ● | ● | ● |
| Rear tonneau cover | ● | ● | ● |
| Driver's footrest | ● | ● | ● |
| Fully trimmed boot with light | ● | ● | ● |
| Cruise control | - | ● | ● |

| Audio | GS | GLS | CDX |
|---|----|-----|-----|
| Integrated radio/cassette player (6 speaker) | ● | - | - |
| Integrated radio/CD tuner (6 speaker) | - | ● | ● |
| Roof aerial | ● | ● | ● |
| Toyota Satellite Navigation System (turn-by-turn) | ○ | ○ | ● |
| CD autochanger | ○ | ○ | ○ |
| Mini-disc changer | ○ | ○ | ○ |

| Ventilation | GS | GLS | CDX |
|--|----|-----|-----|
| Single (front) air conditioning | ● | - | - |
| Dual (front and rear) air conditioning | - | ● | ● |
| Front and rear door mounted electric windows | ● | ● | ● |
| Clean air filter | ● | ● | ● |
| Air-recirculation | ● | ● | ● |

| Security | GS | GLS | CDX |
|---|----|-----|-----|
| Remote alarm with perimeter and microwave interior protection | ● | ● | ● |
| Transponder key engine immobiliser | ● | ● | ● |
| Steering column lock | ● | ● | ● |
| Lockable glove box | ● | ● | ● |
| Vehicle parts marking | ● | ● | ● |
| Security window etching | ● | ● | ● |
| Double locking | ● | ● | ● |
| Visible VIN | ● | ● | ● |

| Seating, upholstery and trim | GS | GLS | CDX |
|--|----|-----|-----|
| Driver and passenger seat recline and slide adjustment | ● | ● | ● |
| Driver seat height adjustment | ● | ● | ● |
| 2nd and 3rd row seat slide function | ● | ● | ● |
| Cloth seat trim and door inserts | ● | ● | ● |
| 8 seat capacity ⁺ | ● | ● | - |
| 60:40 split on seat back and recline function on 2nd row seats (8 seat models) | ● | ● | - |
| Seat cushion tip-up facility on 3rd row seats (8 seat models) | ● | ● | - |
| 7 seat capacity ⁺ | - | ● | ● |
| Individual detachable and foldable 2nd row and 3rd row seats (7 seat models) | - | ● | ● |
| 'Table top' feature on back of 2nd row seats (7 seat models) | - | ● | ● |

| Storage | GS | GLS | CDX |
|--|----|-----|-----|
| Dual glove box | ● | ● | ● |
| Driver's dashboard mounted storage box | ● | ● | ● |
| Auxiliary storage box | ● | ● | ● |
| Front seat back pockets | ● | ● | ● |
| Front and rear cup holders* | ● | ● | ● |
| Bottle holders | ● | ● | ● |
| Storage bins for all rows | ● | ● | ● |

| Exterior and body | GS | GLS | CDX |
|--|----|-----|-----|
| Body coloured door handles | ● | ● | ● |
| Chrome grille | ● | ● | ● |
| Body coloured bumpers | ● | ● | ● |
| Front fog lamps | ● | ● | ● |
| Twin sliding rear doors with lock function | ● | ● | ● |
| Roof rails | - | ● | ● |
| 15" steel wheels with wheel covers | ● | - | - |
| 15" alloy wheels with locking wheel nuts | ○ | ● | ● |
| 16" alloy wheels with locking wheel nuts | ○ | ○ | ○ |
| 17" alloy wheels with locking wheel nuts | ○ | ○ | ○ |
| Metallic paint | ○ | ○ | ○ |

Option ○ Standard ● Not Available -

⁺ GLS models can be ordered with either 7 seat or 8 seat configuration.

* Front cup holders are floor mounted on manual versions and dashboard mounted on automatic versions.

Peace of mind

Previa has been redesigned from top to bottom so not only is it a brand new car, it also offers a brand new way of looking after it once it's yours. Toyota's global reputation for quality and integrity means the new Previa can add peace of mind to its own highly individual range of attributes.

On the day you purchase your Previa, your dealer will present you with a 'Previa Passport'; a guide to living with your Previa and making the most of its considerable range of features. Your dealer will explain the car to you, and always be there, should you require any assistance.

Health and Safety

Your dealer will also talk you through Previa very own Health and Safety programme. It's very simple. Your Previa will only need a full 'Health and Safety' check once every two years, or 20,000 miles if you enjoy driving it as much as we think you will. An intermediate oil change with additional 'Health and Safety' checks are also recommended every year or 10,000 miles.

Warranty

We're so confident each and every Previa is so well built that it comes with a three-year or 60,000 miles warranty against any mechanical failure. In addition, the paintwork, no matter what colour you select, is guaranteed against imperfections for three years too. Also, the body is guaranteed for 12 years against corrosion perforation.



Customer services



When you buy a Toyota, you automatically become a member of one of the most exciting and innovative clubs for car owners in the UK - Club Toyota. As well as giving you one year's Eurocare Roadside Assistance run in conjunction with the RAC, Club membership provides a host of other valuable benefits. These include special rates for car and travel insurance plus an exclusive travel service designed to save you time and money. Club Toyota also offers reduced price cinema and theatre tickets and the opportunity to participate in a variety of special events. You'll find all the details in the quarterly magazine written specifically for Toyota drivers: In Front. **To find out more about Club Toyota call 0845 275 5555.**



Toyota Insurance is available for Toyota owners at competitive premiums. To obtain details of the benefits included and to arrange a quotation, please contact your local Toyota Dealer.



Toyota Fleet provides complete business solutions for companies that run a fleet of vehicles. For more information on how Toyota Fleet can deliver your fleet requirements either contact your local Toyota Dealer or the Toyota Fleet Business Centre on 0845 271 2712.



Toyota Drive Plans make acquiring and maintaining your new car as easy as driving it. They offer a choice of affordable ways to help you buy, finance, service and maintain your Toyota. The range of plans has been structured to offer you flexibility, easy budgeting and peace of mind.

- **Easy Start is an exciting new low deposit plan.**
- **Easy Care offers the complete reassurance of prepaid servicing.**
- **Easy Drive is a comprehensive plan which takes care of most of your motoring needs for 2 to 3 years with one monthly payment .**
- **Business Drive is a fully maintained contract hire package most suited to small business customers.**

Whatever your personal preference, your Toyota Dealer can tailor a Drive Plan to suit your needs perfectly - driving a new car has never been so easy.

Written quotations available on request. All agreements subject to status. Indemnities may be required.



Every new Toyota comes with a three year/60,000 mile manufacturers warranty. Toyota offers you the opportunity to renew your warranty annually after the initial warranty period expires until the vehicle is 7 years old. No unexpected bills or concerns. In fact, nothing to pay beyond routine servicing and maintenance.

Toyota warranties offer equivalent cover to the manufacturers warranty, covering all of the main components of your vehicle (with the exception of batteries, corrosion of exhaust and damage or wear to interior trim).

Our warranty range offers you choice and flexibility, based on the vehicles age and engine size. All allow for an unlimited annual mileage and special low user discounts are available for those covering less than 10,000 miles a year. Warranty cover also includes Club Toyota membership including UK RAC and Eurocare Roadside Assistance, car hire up to 5 days after the first 24 hours, hotel expenses and free MOT test cover.

For further information please contact your local Toyota dealer.



In the event of an emergency Toyota offers free of charge to Toyota owners a comprehensive management service which includes advice, assistance and practical help. Please contact your local Toyota Dealer for further details.

Toyota Approved Used Car Scheme. Please contact your local Toyota Dealer for details.