



# The Vario

Specification Sheet



Mercedes-Benz

# Vario Range Finder

Model	GVW (tonnes)	Engine (Cyl/hp)	Wheelbase (mm)			Typical Seating Capacity
			3700	4250	4800	
<b>Vans</b>						
614D	5.99	4/136	●	●	-	-
814D	7.49	4/136	●	●	-	-
814DA	7.49	4/136	●	-	-	-
<b>Chassis Cabs</b>						
614D	5.99	4/136	●	●	-	-
814D	7.49	4/136	●	●	●	-
814DA	7.49	4/136	●	-	-	-
<b>Vario for PCV</b>						
614D Mobility	5.99	4/136	●	-	-	16
614D Mobility	5.99	4/136	-	●	-	19
614D Coach	5.99	4/136	-	●	-	19
<b>Vario Chassis Cowl</b>						
614D Mobility	5.99	4/136	●	-	-	16
814D Bus	7.49	4/136	-	●	-	25 + standees
814D Bus	7.49	4/136	-	-	●	31 + standees
814D Coach	7.49	4/136	-	-	●	31

# Vario Chassis Cab

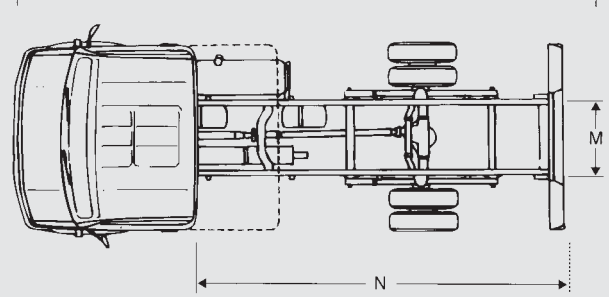
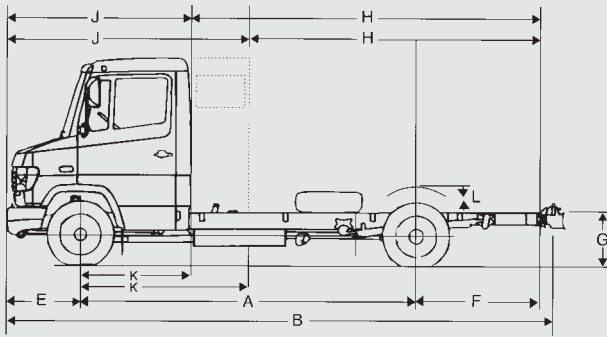

## DIMENSIONS (mm)

### Exterior dimensions

	614D		814D			814DA
	3700	4250	3700	4250	4800	3700
A Wheelbase	3700	4250	3700	4250	4800	3700
B Overall length (inc. under run guard)	6060	6940	6060	6940	7485	6060
C Overall width	2205	2205	2206	2206	2206	2240
D Overall cab height (unladen): Standard	2370	2370	2405	2405	2405	2505
Crew Cab	2375	2375	2410	2410	2410	2515
E Front overhang	820	820	820	820	820	820
F Rear overhang (to end of frame)	1370	1700	1370	1700	1700	1370
G Frame height at rear (unladen)	770	770	790	790	790	905
H Back of cab to end of frame: Standard	3850	4730	3850	4730	5730	3850
Crew Cab	2930	3810	2930	3810	4810	2930
J Front bumper to back of cab: Standard	2040	2040	2040	2040	2040	2040
Crew Cab	2960	2960	2960	2960	2960	2960
K Front axle to back of cab: Standard	1220	1220	1220	1220	1220	1220
Crew Cab	2140	2140	2140	2140	2140	2140
L Wheel arch clearance above frame	210	210	216	216	216	216
M Frame width	848	848	850	850	850	850
N Typical body length (feet)	15	18	15	18	21	15
P Rear track	1641	1641	1640	1640	1640	1640

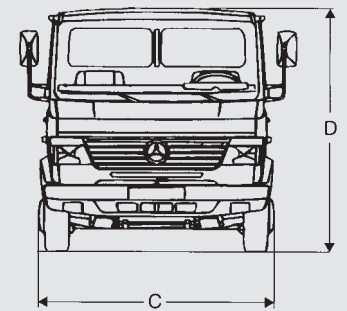
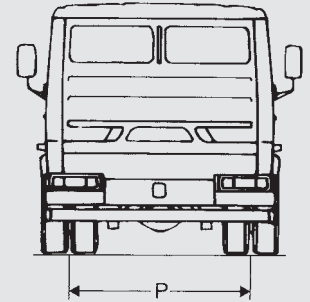

## WEIGHTS (kg)

	614D		814D			814DA
	3700	4250	3700	4250	4800	3700
Wheelbase (mm)	3700	4250	3700	4250	4800	3700
GVW	5990	5990	7490	7490	7490	7490
<b>Kerb weights*</b>						
Front axle	1650	1680	1795	1845	1895	2095
Rear axle	825	830	870	890	910	1205
Total	2475	2510	2665	2735	2805	3300
Payload	3515	3480	4825	4755	4685	4190
<b>Plated weights</b>						
Front axle	2300	2300	2500	2500	2500	2500
Rear axle	4300	4300	5600	5600	5600	5600
GTW (unbraked)	6740	6740	8240	8240	8240	8240
GTW (braked)	9490	9490	10990	10990	10990	10990

\* Weights are to standard specification with full tank of fuel, spare wheel and tools.

All weights are subject to ±5% manufacturing tolerance. The right is reserved to alter specifications or equipment without notice.

Weight of Crew Cab +185kg.

PLEASE SEE INTERIOR AND EXTERIOR FOR GENERAL INFORMATION

# Vario for Passenger Carrying Conversion

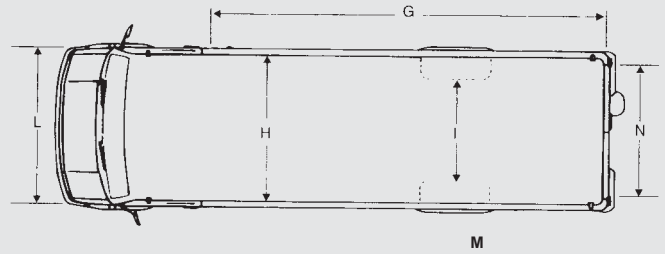
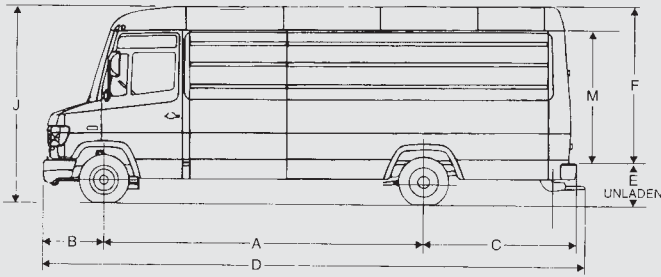

## DIMENSIONS (mm)

### Exterior dimensions

	614D Mobility		614D Coach
A Wheelbase	3700	4250	4250
B Front overhang	820	820	820
C Rear overhang	1695	2025	2025
D Overall length	6215	7210	7210
E Rear entrance height (unladen)	845	840	N/A
F Interior height	1930	1930	1930
G Passenger compartment length	4050	4930	4930
H Interior width	1900	1900	1900
I Width at wheel arches	1042	1042	1042
J Overall height (unladen)	2830	2820	2820
K Rear track	1641	1641	1641
L Overall width (excluding mirrors)	2205	2205	2205
M Rear door height	1630	1630	N/A
N Rear door width	1650	1650	N/A

## WEIGHTS (kg)

	614D Mobility		614D Coach
<b>Wheelbase (mm)</b>	<b>3700</b>	<b>4250</b>	<b>4250</b>
<b>GVW</b>	<b>5990</b>	<b>5990</b>	<b>5990</b>
<b>Kerb weights</b>			
Front axle	1835	1860	1860
Rear axle	1580	1735	1735
Total	3415	3595	3595
Conversion/passenger allowance	2575	2395	2395
<b>Plated weights</b>			
Front axle	2300	2300	2300
Rear axle	4300	4300	4300

*Dimensions and kerb weights are provisional and are to standard specification with full tank of fuel, spare wheel and tools. All weights are subject to ±5% manufacturing tolerance. The right is reserved to alter specifications or equipment without notice.*

PLEASE SEE INTERIOR AND EXTERIOR FOR GENERAL INFORMATION

# Vario Chassis Cowl for Passenger Carrying Conversion

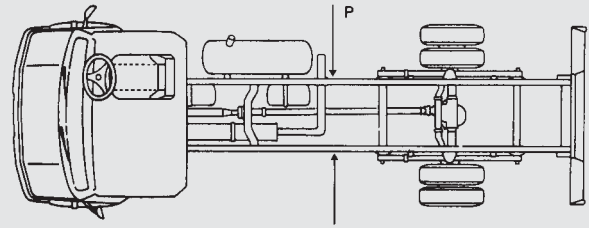
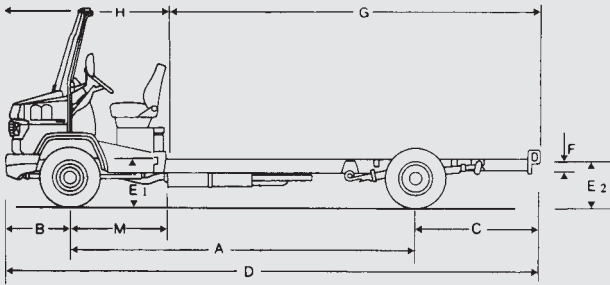

## DIMENSIONS (mm)

### Exterior dimensions

	614D	814D Bus				814D
	Mobility	Air Suspension	Steel Suspension	Air Suspension	Steel Suspension	Coach
A Wheelbase	3700	4250	4250	4800	4800	4800
B Front overhang	820	820	820	820	820	820
C Rear overhang	1370	1700	1700	1700	1700	1700
D Overall length	6055	6935	6935	7485	7485	7485
E <sup>1</sup> Frame height front (unladen)	-	590	705	590	700	705
E <sup>2</sup> Frame height rear (unladen)	770	615	790	615	790	650
F Frame depth	128	130	130	130	130	130
G Frame length from rear of cab floor	3870	4750	4750	5300	5300	5300
H Bumper to rear of cab floor	2020	2020	2020	2020	2020	2020
K Rear track	1640	1640	1640	1640	1640	1640
L Overall width	2206	2206	2206	2206	2206	2206
M Front axle to rear of cab floor	1200	1200	1200	1200	1200	1200
P Frame width	850	850	850	850	850	850

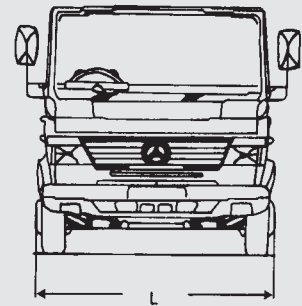
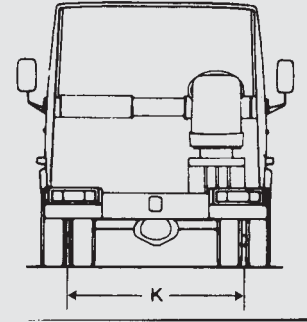

## WEIGHTS (kg)

	614D	814D Bus				814D
	Mobility	Air Suspension	Steel Suspension	Air Suspension	Steel Suspension	Coach
Wheelbase (mm)	3700	4250	4250	4800	4800	4800
GVW	5990	7490	7490	7490	7490	7490
<b>Kerb weights</b>						
Front axle	1505	1755	1745	1820	1770	1820
Rear axle	775	1025	930	1025	935	1030
Total	2280	2780	2675	2845	2705	2850
Body/passenger allowance	3710	4710	4815	4645	4785	4640
<b>Plated weights</b>						
Front axle	2300	2500	2500	2500	2500	2500
Rear axle	4300	5600	5200	5600	5200	5600

Dimensions and kerb weights are provisional and are to standard specification with a full tank of fuel, spare wheel and tools.

All weights are subject to ±5% manufacturing tolerance. The right is reserved to alter specifications or equipment without notice.

PLEASE SEE INTERIOR AND EXTERIOR FOR GENERAL INFORMATION

# Engine and transmission

## Engine details

This information relates to all Vario models in this brochure

<b>Type</b>	Mercedes-Benz OM904LA 4 cylinder turbo-charged and intercooled diesel
<b>Max. power</b>	136bhp/100kW @ 2200rpm
<b>Max. torque</b>	520Nm/384lbft @ 1200-1600rpm
<b>Capacity (cc)</b>	4250cc
<b>Fuel injection</b>	Direct injection via unit injectors

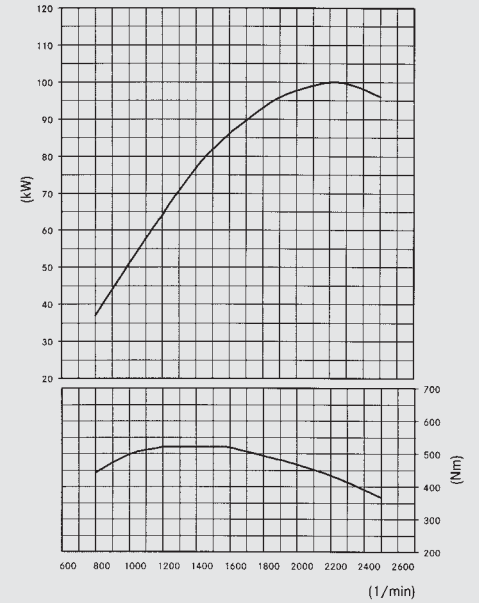

## Transmission details

This information relates to the standard transmission fitted to all Vario models in this brochure

### Gearbox

(All models: ZF 5S-42 synchromesh)  
814DA only: Transfer gearbox with permanent drive to front axle and interaxle diff. lock.  
Off road ratio 1.67:1

### Clutch

Hydraulically operated 362mm single dry plate

### Axles

Front: Mercedes-Benz rigid stub  
(814DA: permanently driven axle)  
Rear: Mercedes-Benz hypoid  
(814DA: with diff. lock)

Gearbox	1st gear ratio	2nd gear ratio	3rd gear ratio	4th gear ratio	5th gear ratio	Reverse gear ratio
<b>Type: ZF S 5-42</b>	5.72	2.94	1.61	1.00	0.76	5.24*

\* Vario Chassis Cowl reverse gear ratio is 5.29.

PLEASE SEE INDIVIDUAL VEHICLE PAGES FOR SPECIFIC INFORMATION

# Axle ratios and vehicle performance

<b>Vario Van</b>	<b>614D</b>	<b>814D</b>	<b>814DA</b>
Gross vehicle weight	5990	7490	7490
Standard axle ratio	3.63	3.63	4.30
Maximum speed (mph)	72	72	64
Maximum gradient (%)	39	36	44

<b>Chassis Cab</b>	<b>614D</b>	<b>814D</b>	<b>814DA</b>
Gross vehicle weight	5990	7490	7490
Standard axle ratio	3.63	3.63	4.30
Maximum speed (mph)	71	72	61
Maximum gradient (%)	40	37	44

<b>Vario for PCV</b>	<b>614D Mobility</b>	<b>614D Coach</b>
Gross vehicle weight	5990	5990
Standard axle ratio	3.15	3.15
Maximum speed (mph)	79	79
Maximum gradient (%)	41	41

<b>Chassis Cowl for PCV</b>	<b>614D Mobility</b>	<b>814D Bus</b>	<b>814D Coach</b>
Gross vehicle weight	5990	7490	7490
Standard axle ratio	3.63	4.30	3.15
Maximum speed (mph)	70	58	82
Maximum gradient (%)	48	43	36

*Optional rear axle ratios available on request*

# Interior

Features are common to all models unless otherwise stated

<b>Trim</b>	Fibre-glass reinforced engine cover Moulded facia and padded steering wheel with impact resistant centre boss Rubber floor covering	<b>Instruments</b>	Coolant temperature gauge Fuel gauge Rev counter System test button Air pressure gauges
<b>Seating</b>	Driver's 4-way adjustable seat with head restraint (not 814D Chassis Cowl)	<b>Visibility</b>	Laminated windscreen Heated rear view mirrors
<b>Controls</b>	Air vent pollen filter Bonnet release Hazard warning lights Heater and demister with multiple outlets Key start with steering lock and transponder engine immobiliser (Thatcham Category 2) Recirculating air switch and three-speed fan with directional air flow switch Rotary switch for driving lights/fog light Steering column stalk for indicators, main beam, wipers and horn	<b>Stowage</b>	Lockable glovebox with hinged drop-lid Pen tray on engine cover

PLEASE SEE INDIVIDUAL VEHICLE PAGES FOR SPECIFIC INFORMATION



# Additional interior features

	Van	Chassis Cab	Vario for PCV	Chassis Cowl for PCV
Cab area headlining	●	●	●	-
Rear cab wall lining	-	●	-	-
Door trim panels with cloth inserts and arm rests	●	●	●	-
Hard-wearing patterned cloth seats	●	●	●	-
Driver and passenger grab handles	●	●	-	-
Driver grab handle	●	●	●	-
Dual passenger seat with head restraints (814DA: single passenger seat)	●	●	○	-
3-point inertia reel seat belts	●	●	●	-
Lap belt for centre seat	●	●	○	-
Temporary transport seat - suitable for body builder fitment of PSV type seat	-	-	○	●
Ashtray and cigarette lighter	●	●	●	-
Cab interior light	●	●	●	-
Flask holder beside driver's seat	●	●	●	-
Radio cassette with two speakers	●	●	●	-
Load area light switch	●	-	●	-
1-day/2-man automatic tachograph	●	●	●*	●*
Speedometer	-	-	●**	●**
Deep opening side windows with manual winders	●	●	●	-
Full width roller sun blind	●	●	●	-
Opening quarter lights	●	●	●	-
Coat hook	●	●	●	-
Deep and wide door pockets	●	●	●	-
Document pocket on bulkhead (between seats)	●	●	-	-
Tinted windscreen	○	○	●	○
Front fog lamps	○	○	●*	●*

● *Standard*

○ *Optional*

- *Not available*

\* *Coach version only*

\*\* *Bus and Mobility versions only*

# Exterior

Features are common to all models unless otherwise stated

<b>Wheels and Tyres</b>		<b>Electrical System</b>	
<b>614D</b>		Voltage	24 Volt
Wheels	6J x 16	Battery	2 x 66Ah
Tyres	215/75R 16		2 x 135Ah for 814D Chassis Cowl only
<b>814D/814DA</b>		Alternator	2 x 88Ah for Vario for PCV Coach model
Wheels	6.00 x 17.5		28 Volt/80 Amp
Tyres	205/75R 17.5	Road Lights	Halogen headlamps
<b>Spare Wheel</b>			Halogen front fog lamps (Vario for PCV and Chassis Cowl Coach models only)
614D/814D	Van/Chassis Cab/		Headlamp levelling
	Vario for PCV		Indicator side repeaters
	814DA		Rear fog lamp
	Chassis Cowl		Reversing lights
			Roof marker lights (not Chassis Cowl)
		Warning Lights	Air filter condition indicator
<b>Brakes</b>			Battery no charge
Front/Rear	Floating caliper discs including ABS (anti-lock braking system) with pad wear indicator		Direction indicators
Service	Dual circuit air/hydraulic with load sensing valve on rear axle		Engine pre-heater
Parking	Air assisted, spring operated parking brake on rear axle		Hazard lights
Engine	Engine exhaust brake (Vario for PCV and Chassis Cowl only)	Fuse Box	Low brake fluid level
Retarder	Telma CC80 (814D Chassis Cowl only)	Safety equipment	Low oil pressure
<b>Suspension</b>			Main beam/flasher
Van/Chassis Cab and Vario for PCV	Parabolic leaf springs with shock absorbers and stabilisers Comfort ride suspension (Vario for PCV only)		Parking brake
Chassis Cowl – 614D Mobility	Parabolic leaf springs with shock absorbers and stabilisers including comfort ride suspension		Rear fog lamp
Chassis Cowl – 814D Bus	Either front and rear parabolic leaf springs or front and rear air suspension. (Air suspension enables bodybuilders to achieve DiPTAC step/floor dimensions)		Inside glove box
Chassis Cowl – 814D Coach	Front – parabolic leaf spring Rear – air suspension		Battery isolation switch on driver's seat box (Vario for PCV and Chassis Cowl only)
<b>Steering</b>			
Type	Power-assisted recirculating ball steering box		
Turning circle:			
3.7m wheelbase	Kerb to kerb – 12.7m, wall to wall – 13.4m		
4.25m wheelbase	Kerb to kerb – 14.4m, wall to wall – 15m		
4.8m wheelbase	Kerb to kerb – 15.8m, wall to wall – 16.6m		

PLEASE SEE INDIVIDUAL VEHICLE PAGES FOR SPECIFIC INFORMATION

## Body – These exterior features are common to all models unless otherwise stated

<b>Construction</b>	All steel construction. Ladder type, high tensile steel chassis frame. Channel section side members and tubular cross members (Chassis Cab and Chassis Cowl). Side guards (Van only). Towing eyes on front. Rear under-run guard (Chassis Cab only). Reservoir and feed for installation of air door (Chassis Cowl 814D only). Engine electrical stop fly lead in engine compartment (Chassis Cowl 814D only).		<b>Load area (Van)</b>		Cab access	Hinged driver and passenger doors
	<b>Service access</b>	Internally released hinged bonnet for access to: Clutch/Brake fluid Engine coolant Engine oil Power steering reservoir Windscreen washer reservoir Batteries located in compartment under driver's seat		Floor	Wooden floor with resin non-slip finish Flat-topped wheel arches	
<b>Standard body colours (not Chassis Cowl)</b>		Arctic White	Orchid Green	Side Access	Nearside lockable sliding side load door with internal access step – grab handle on left-hand side	
	Ravenna Yellow	Piedmont Red	Rear Access	Full height lockable rear doors with stop Full opening to 270° Grab handle on right-hand door pillar Entrance step		
<b>Protection and finish</b>	Paint	Phosphate treatment, primer and gloss paint finish	Load Restraint	5 pairs of load lashing rings along edges of floor		
			Lighting	Interior load area lighting switched independently from dashboard or activated by nearside or rear loading doors		
<b>Passenger area (Vario for PCV)</b>	Cavities	Below waist rail wax protection	Bulkhead	Full steel panel with fabric covering on cab side		
					Underbody	Underfloor and chassis are waxed Underbody and wheelarches are undersealed and rust inhibited
Entry Steps	Plastic covered	Passenger compartment	Hinged driver and passenger doors 270° hinged rear doors with windows (Mobility only) Hinged emergency exit door on offside behind rear axle with top hinged rear boot and full width window (Coach only)			
				Bumpers	Front and rear bumpers moulded in damage-resistant, impact-absorbing plastic (Van and Vario for PCV only) Front bumper only (Chassis Cab/Chassis Cowl)	Floor

## Additional exterior features

Fuel Tank	Van			Chassis Cab					Vario for PCV		Chassis Cowl		
	614D	814D	814DA	614D	814DA	814D/37	814D/42	814D/48	614D Mob	614D Coach	614D Mob	814D Bus	814D Coach
• 2 x 70 litre with locking fuel cap	-	-	-	-	-	-	-	-	○	●	-	-	-
• 70 litre with locking fuel cap	○	○	●	●	●	●	-	-	●	○	●	-	-
• 125 litre with locking fuel cap	-	-	-	-	-	-	●	●	-	-	-	●	●
• 2 x 55 litre with locking fuel cap	●	●	-	-	-	-	-	-	-	-	-	-	-

- Standard
- Optional
- Not available

# Optional Equipment

## Optional Extras

	Van			Chassis Cab					Vario for PCV		Chassis Cowl			
	614D	814D	814DA	614D	814DA	814D/37	814D/42	814D/48	614D Mob	614D Coach	614D Mob	814D/42 Bus	814D/48 Bus	814D Coach
Alternator 100Ah	-	-	-	-	-	-	-	-	-	-	○	○	○	○
Allison automatic gearbox (alternative axle ratio may be required)	○	○	-	○	-	○	○	○	○	○	○	○	○	-
Tachograph	●	●	●	●	●	●	●	●	○	●	○	○	○	●
Batteries uprated to 88Ah	○	○	○	○	○	○	○	○	○	●	-	-	-	-
Bulkhead (various options)	○	○	○	-	-	-	-	-	-	-	-	-	-	-
Cab roof hatch (steel or glass)	○	○	○	○	○	○	○	○	-	-	-	-	-	-
Crew Cab with tip-up dual passenger seat	-	-	-	○	○	○	○	○	-	-	-	-	-	-
Differential lock	○	○	○	○	○	○	○	○	-	-	-	-	-	-
Dual front passenger seat	●	●	-	●	-	●	●	●	○	○	-	-	-	-
Electric cab windows	○	○	○	○	○	○	○	○	○	○	-	-	-	-
Electrically adjustable door mirrors	○	○	○	○	○	○	○	○	○	○	○	○	○	○
Exhaust brake	○	○	○	○	○	○	○	○	●	●	●	●	●	●
Front fog lamps	○	○	○	○	○	○	○	○	○	●	○	○	○	●
Gearbox PTO (various options)	○	○	○	○	○	○	○	○	-	-	-	-	-	-
Headlamp washers	○	○	○	○	○	○	○	○	○	○	○	○	○	○
Heated driver's seat	○	○	○	○	○	○	○	○	○	○	-	-	-	-
Heavy duty rear stabiliser	○	○	○	○	○	○	○	○	-	-	-	-	-	-
High roof (3.7m wheelbase only)	○	○	○	-	-	-	-	-	-	-	-	-	-	-
Hydraulic suspension seats	○	○	○	○	○	○	○	○	○	○	-	-	-	-
Omission of bulkhead	○	○	○	-	-	-	-	-	-	-	-	-	-	-
Omission of passenger seat	○	○	○	○	○	○	○	○	●	●	●	●	●	●
Rear bench seats (Crew Cab)	-	-	-	○	○	○	○	○	-	-	-	-	-	-
Single passenger seat	○	○	●	○	●	○	○	○	○	○	-	-	-	-
Sliding cab doors	○	○	○	-	-	-	-	-	-	-	-	-	-	-
Sliding side load door - offside	○	○	○	-	-	-	-	-	○	○	-	-	-	-
Sliding side load door - omit nearside door	○	○	○	-	-	-	-	-	●	●	-	-	-	-
Telma retarder	-	-	-	-	-	-	-	-	○	○	○	●	●	●
Tinted glass	○	○	○	○	○	○	○	○	○	○	-	-	-	-
Windows in rear doors	○	○	○	-	-	-	-	-	●	●	-	-	-	-
1 x 70 litre fuel tank (std on 814DA)	○	○	●	-	-	-	-	-	-	-	-	-	-	-
180° rear doors	○	○	○	-	-	-	-	-	-	-	-	-	-	-
2800kg front axle capacity	-	○	-	-	○	○	○	○	-	-	-	○	○	○

- Standard
- Optional
- Not available

PLEASE SEE INDIVIDUAL VEHICLE PAGES FOR SPECIFIC INFORMATION

# Glossary

<b>GVW – ‘Gross Vehicle Weight’</b>	- The maximum allowable overall weight of a laden vehicle.
<b>GTW – ‘Gross Train Weight’</b>	- The maximum allowable overall weight of a laden vehicle and trailer combination. Shown for both ‘unbraked’ and ‘braked’ trailers in the specification pages.
<b>PCV</b>	- Passenger Carrying Vehicle.
<b>Wheelbase</b>	- The dimension from centre of front wheel to centre of rear wheel.

The illustrations may show accessories and items of optional equipment which are not part of the standard specification.  
Colours may differ slightly from those shown, owing to the limitations of the printing process. For more information  
please contact your Mercedes-Benz van dealer or visit our website: