

Hilux

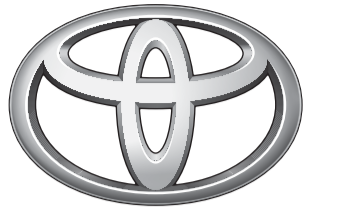

TOYOTA



For Toyota,
quality is not just a promise;
it's a way of life

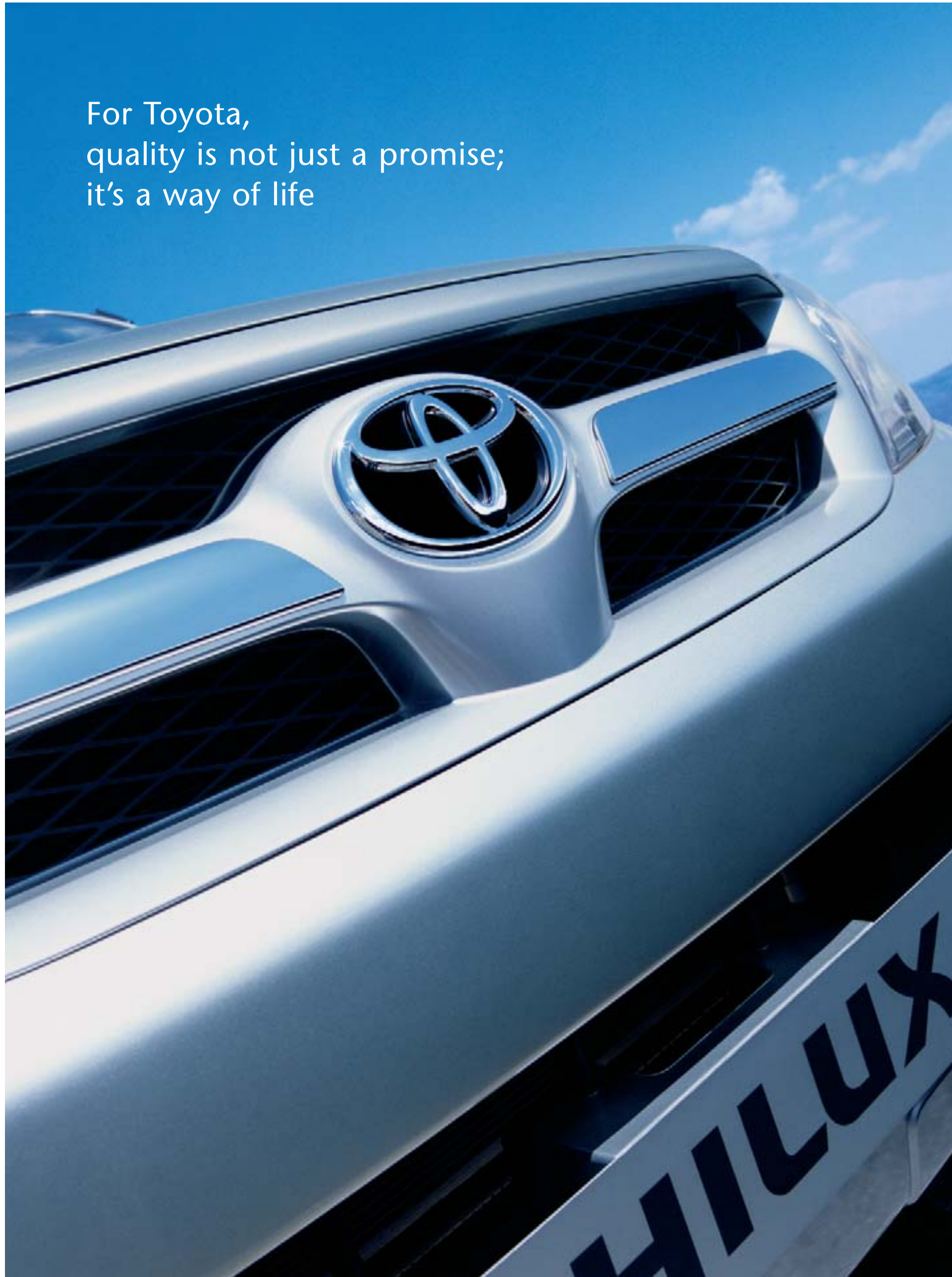

Nothing is so good that it cannot be made better. That is why we strive for constant improvement in everything we do. It is not a motto. Or a mission statement we hang on the wall and forget about. It is simply the way we do things. We have a word for it: 'kaizen'. It means 'continuous improvement' and it is the key principle that guides us in our pursuit of total quality.

"From now on, I want everybody to put their efforts together and unite in finding a way to make superior vehicles."

Kiichiro Toyota, Founder
Toyota Motor Corporation, May
1939

This commitment to quality results in real benefits – benefits that enhance the quality of your life. We know this because you tell us so by consistently voting Toyota highly in independent customer satisfaction surveys. This is also evident through the outstanding results Toyota achieves in the Euro NCAP safety tests. Most of all we know this because we make it our business to find out how to give you the best possible ownership experience, from when you first buy your car, right up to when you ultimately sell it.

What this means for you is that every time you get into the driving seat of a Toyota and start the engine, you will experience a feeling of complete confidence. Confidence that comes from knowing that the car you are driving is designed and engineered with the very highest standards of quality and reliability in mind. For Toyota, quality is not just a promise; it's a way of life.

The Toyota Hilux. Ready. Willing. And able to do anything, anytime, anywhere

The Toyota Hilux gives you the freedom to do whatever you want, whenever you want. No matter what the activity, no matter what's up against you, nothing can stand in its way.

The Toyota Hilux offers endless possibilities. And the kind of versatility where the only limit is your imagination.



Contents

Toyota Hilux

Hilux history

Driving experience

Driving dynamics
Driving dynamics –
off-road/on-road

Performance

Engine

Comfort and quality

Body styles
Hilux Double Cab
Hilux Single Cab
Driver ergonomics
Ergonomics

Safety

Active and passive safety

Grades

Grades

Colour and trims

Exterior colours and
interior trims

Technical data

Specifications
Equipment

Customer Service

Drive Plans

Peace of mind

Toyota customer support

Accessories

Hilux accessories



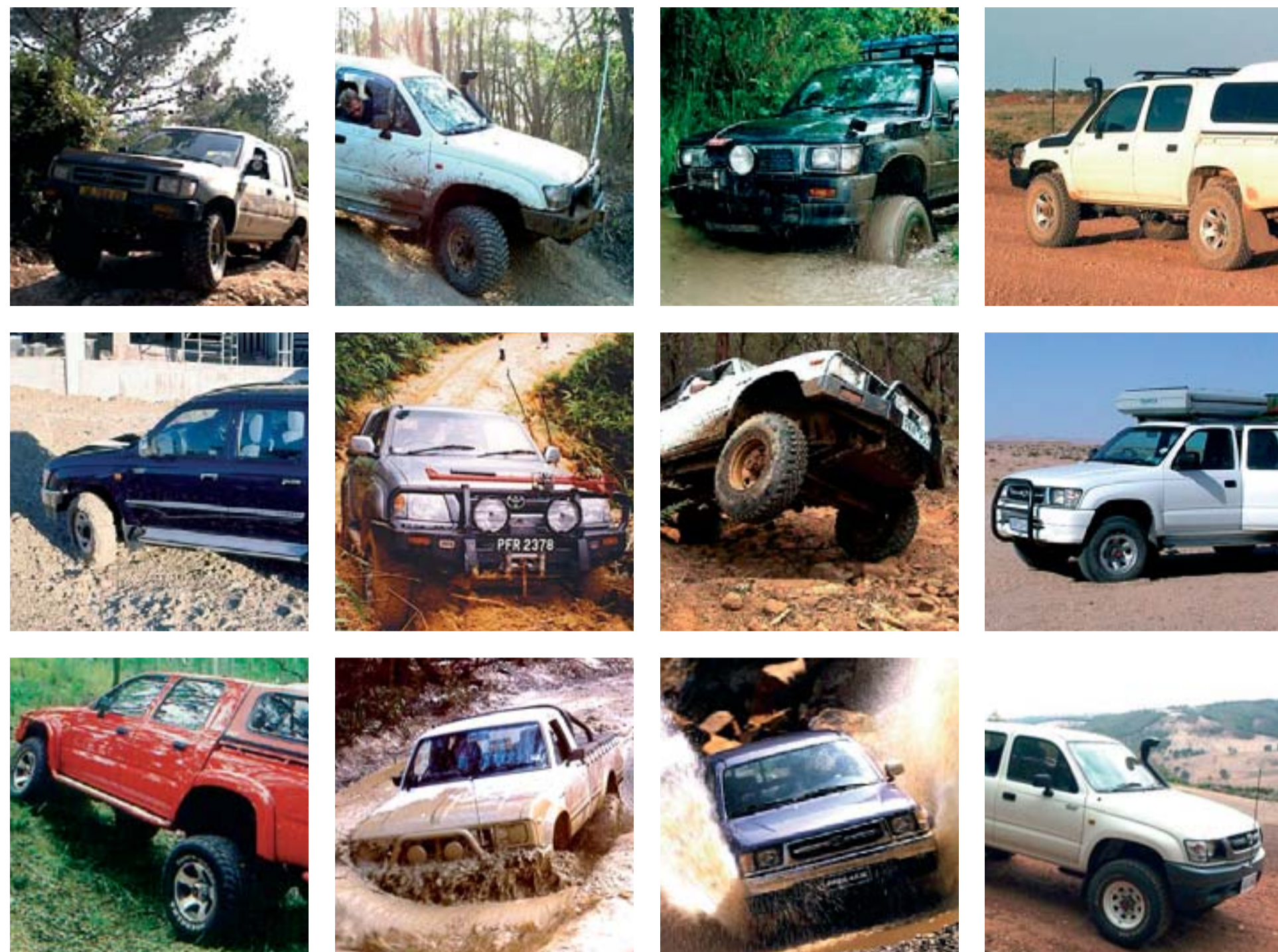

1968



1972



1978



1983



1988



1997



2005

A reputation that's well renowned...

Toyota Hilux has endured some of the harshest environments in the world for almost forty years. First released in Japan in 1967, it soon became known globally for its resolute and uncompromising ability and reliability.

Everyday, Hilux owners everywhere use their vehicle in the most extreme surroundings. Bracing freezing weather in Alaska. Carrying cargo loads across the sand dunes of the Sahara. Negotiating rocky outcrops in the

remote Australian outback. They know, first-hand, that their Hilux can be depended on to climb that incline, cross that river, pull out of that mud. Little wonder, perhaps, that over 12,000,000 models have been sold worldwide.

With Hilux, Toyota's long-standing commitment to quality and durability culminates in a vehicle that millions of people trust on every type of terrain, in all kinds of conditions. And, sometimes, quite literally with their lives.

...and well deserved

As far as proving its worth, we didn't just rely on the Hilux's name and reputation for strength and durability. As part of the development programme for this model, we put it to the test in the most extreme conditions.

First of all, we gave it a durability test in South Africa, and we also included a high-altitude drive at 2,800 m for good measure. But that wasn't testing enough, so to really check-out how the engine stood up where the oxygen is scarce, we took it to Peru and tried it 4,800 m up the Andes, where the oxygen levels are less than 50% of

what they are at sea level, making most engines struggle due to insufficient air intake. Still the Hilux didn't falter, so we sent it to spend 150 hours off-roading at high speed across some of the most unwelcoming terrain on earth in the Australian Outback. Again, the Hilux came through with flying colours. Then we really turned the heat up – literally – with a high temperature test at 47° in Dubai and once more the Hilux coped without a problem, even the airconditioning system, which kept the cabin cool and comfortable. In case your destination is nearer to home, we also tested the Hilux in Europe to make sure that it was just as suitable for the conditions here as it is at the four corners of the globe.

Unbreakable ability? With the Toyota Hilux, it's no empty claim.

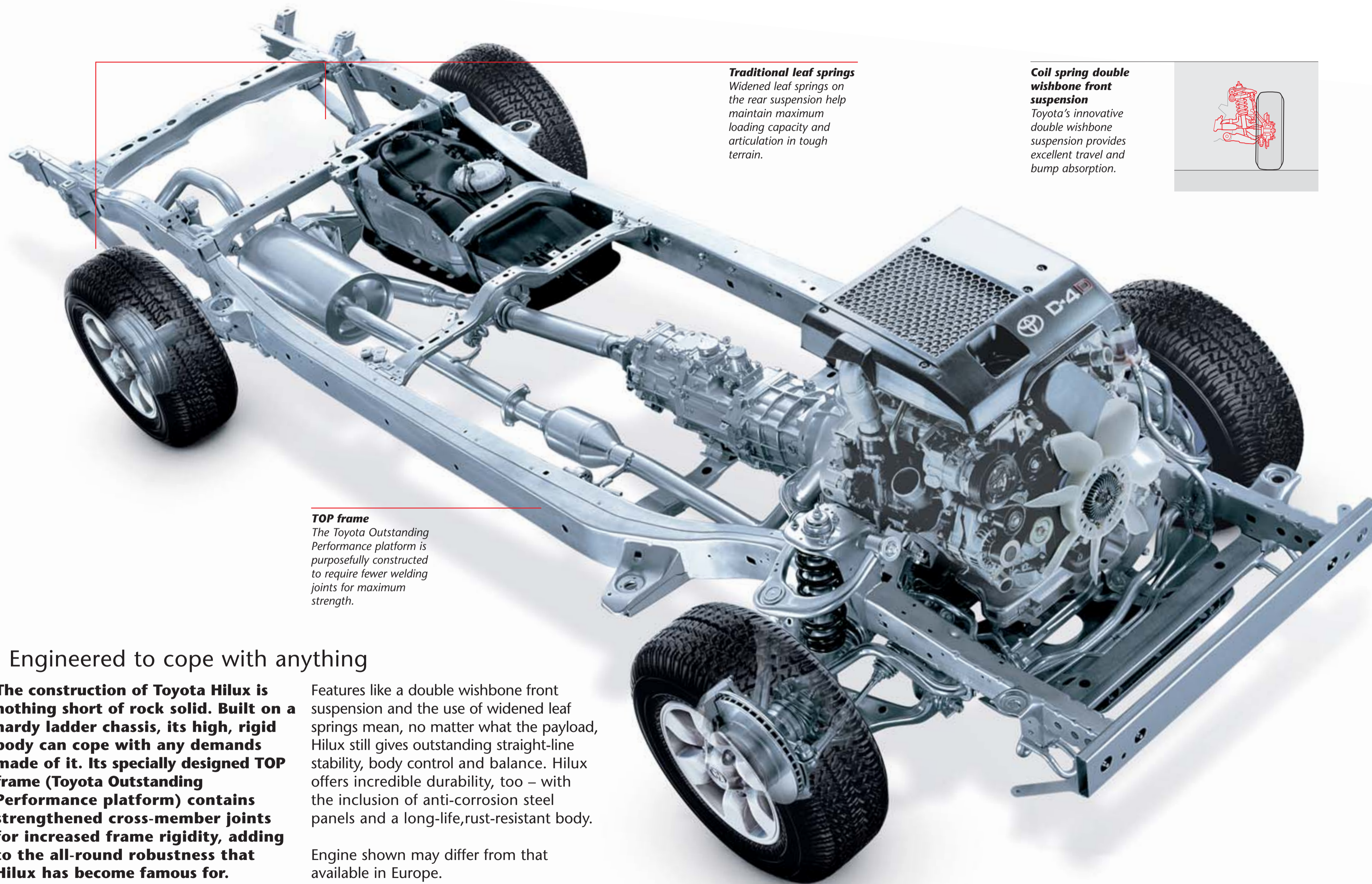

Traditional leaf springs

Widened leaf springs on the rear suspension help maintain maximum loading capacity and articulation in tough terrain.

Coil spring double wishbone front suspension

Toyota's innovative double wishbone suspension provides excellent travel and bump absorption.

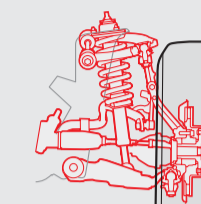

TOP frame

The Toyota Outstanding Performance platform is purposefully constructed to require fewer welding joints for maximum strength.

Engineered to cope with anything

The construction of Toyota Hilux is nothing short of rock solid. Built on a hardy ladder chassis, its high, rigid body can cope with any demands made of it. Its specially designed TOP frame (Toyota Outstanding Performance platform) contains strengthened cross-member joints for increased frame rigidity, adding to the all-round robustness that Hilux has become famous for.

Features like a double wishbone front suspension and the use of widened leaf springs mean, no matter what the payload, Hilux still gives outstanding straight-line stability, body control and balance. Hilux offers incredible durability, too – with the inclusion of anti-corrosion steel panels and a long-life, rust-resistant body.

Engine shown may differ from that available in Europe.



Go anywhere. Off-road...

The unbreakable Toyota Hilux was born to venture off the beaten path. Its steady, shock-absorbing chassis enables even the roughest terrain to be negotiated with incredible stability, while power steering makes traversing any environment seem effortless.

In 4WD, Hilux can easily ascend steep angles. Slippery conditions need never stop it either, thanks to a rear differential lock that allows the rear wheels to be driven with equal power distribution, eliminating wheel spin and instability. As for wading capability, Hilux can take on waters up to 700 mm high, making it a truly all-terrain vehicle.

Wading Depth

Hilux can take on waters up to 700 mm.

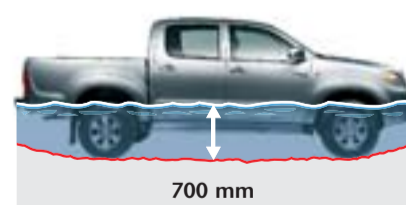

Clearance

Approach Angle 30°
Break over Angle 25°
Departure Angle 26°

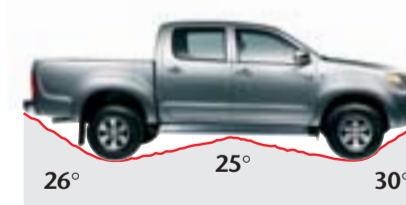

...or on

Hilux is as much designed for on-road travel as it is for off. Take it on a trip through any town or city and you'll soon notice why. Aerodynamic styling and integral sound-reducing materials in the cabin make for a driving experience so quiet you'll almost need reminding you're in a pick-up.

Hilux's meticulously engineered suspension results in a smooth, cushioned ride and its rack-and-pinion-type steering system delivers a more responsive steering feel that's ideal in an urban environment. The Toyota Hilux blends comfort and superior handling to create levels of car-like refinement that might make you forget you're driving a utility vehicle.

Transmission 5 M/T 2WD or 4WD

Hilux is available with an ultra-smooth 5-speed manual transmission and the choice of 2WD or 4WD.



ADD

Hilux's Automatic Disconnecting Differential automatically disconnects power to the front wheels when switching from 4WD to 2WD while on the move, substantially increasing fuel efficiency. (HL, and Invincible grades only.)

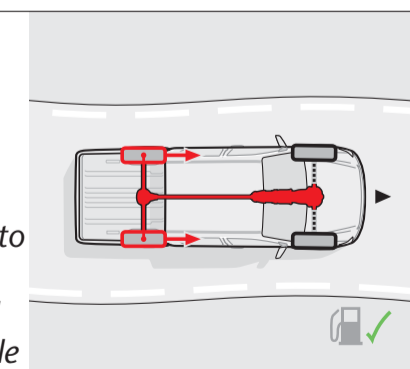



Tow whatever you want

With its strong 2.5 litre D-4D common-rail turbo diesel engine, the Toyota Hilux can tackle the most demanding of tasks. Torque is an outstanding 260 Nm at 1600–2400 rpm*, making short work of even the heaviest tow loads.

Yet, despite this impressive performance, Hilux also delivers exceptionally clean emissions. With its common-rail technology, fuel efficiency is maximised while a precise multi-pilot injection system significantly reduces engine-combustion noise.

Whatever you're pulling, you can count on the Hilux's robust chassis strength and torque to get the job done. And to stay the course when you need it the most.

* In 4WD mode.

D-4D diesel engine
Hilux's turbocharged D-4D 105 engine offers 102 DIN hp.

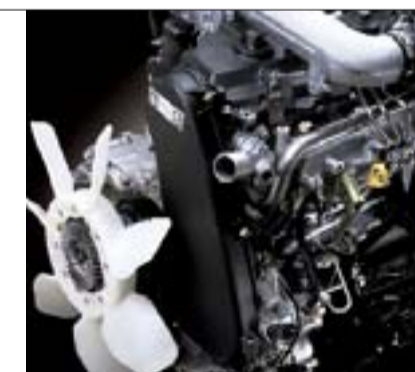

Torque
Hilux's D-4D 105 engine delivers an impressive 260 Nm/1600–2400 rpm*, giving you maximum pulling power in any situation.

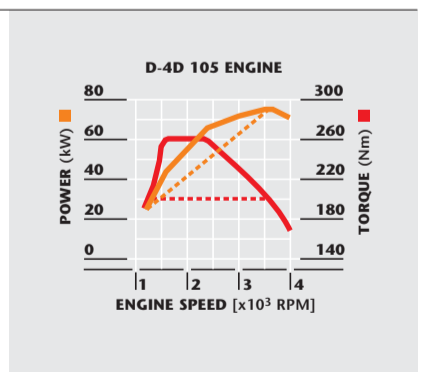

Two unbreakable body styles

From making it through rough terrain to simply cruising across town, the new Toyota Hilux offers truly all-encompassing ability.

Push it to the limit and it'll respond with enthusiasm. Take it to the extreme and it'll just want more. Nothing worries it, nothing scares it, nothing even makes it think twice. With ability this relentless, and the choice of two tough body styles (the resilient Single Cab and the capacious 5-seater Double Cab), the Toyota Hilux has nothing to hold it back. And nor do you.



*The spacious Hilux Double Cab
(HL₂ model shown)*



*The resilient Hilux Single Cab
(4x2 HL₂ model shown)*

Hilux Double Cab. Room for four more

For the ultimate group outing, the Hilux Double Cab is the body style of choice. Five people can ride in it at the same time, with all occupants enjoying more than ample headroom and legroom in spacious surroundings.

The back seats tip up to reveal convenient storage compartments underneath, and rear doors open wide for easy access. Whatever your chosen activity, Hilux Double Cab frees you up to take whoever you want to go with you.



Invincible grade shown.

An outstanding workhorse

The HL₂ grade Hilux is built for one purpose – to work hard

With super-tough interior seat and flooring materials, it will take all the wear and tear you can throw at it. On the outside, a cabin protection ladder rack protects your passengers from items in the load area, whilst the addition of more off-road bias tyres with narrower profile steel wheels and deletion of side steps ensure maximum off-road grip and clearance.

The HL₃ Hilux is the perfect balance between working ability and passenger car luxury. Capable and comfortable, tough but refined a truly multi-purpose vehicle.



HL₂ grade shown.

Space for all your needs

Whether for work or pleasure the Hilux Double Cab has space to seat five in comfort and with a maximum payload of 1085 kg and a deck length of 1520 mm, the Hilux Double Cab can easily accomodate practically anything you would like to carry.



Hilux Double Cab can take a maximum payload of 1085 kg and has a deck length of 1520 mm.



Hilux Single Cab. A resilient worker

The Hilux Single Cab is for those who just want to get on with the job.

Unyielding, tough and uncompromising, it's the perfect business partner, no matter what your business is. It gives you a maximum load space of 1.58 cubic metres and a total payload of 1170 kg* ensuring nothing gets in the way of a solid, hard-day's work.

* 4x2 Single Cab payload quoted.



Hilux Single Cab has a deck width of 1520 mm, deck length of 2315 mm and deck height of 450 mm.





1.



2.



3.



HL₃ grade interior shown with optional leather seats.

Mix business with pleasure

Step into the Toyota Hilux and it's difficult to believe you're not inside a sought-after passenger car. The first thing you'll notice is the high standard of finish as well as seats furnished with a distinctly attractive cloth trim. Manual air conditioning and electrically powered windows and door locks help to add to the all-round car feel that's almost in contrast to Hilux's tough workhorse credentials.

Hilux's ergonomic centre console design also features a radio CD player on the HL₂ and HL₃ grades whilst Invincible features a 6-CD in-dash multichanger and radio cassette. Satellite navigation can be specified for HL₃ and Invincible grades, but this requires the satellite navigation compatible CD audio.

(Audio must be substituted to single CD satellite navigation compatible unit.) And, for extra practicality, there's integral storage in the form of dashboard compartments.

1. Power windows

The power windows have a one-touch down function on the driver's side.

2. Air conditioning

Manual air conditioning adds comfort to your driving experience.

3. Dashboard storage

Extra, handy space for items like wallets and keys.



1.



2.



3.



HL₃ grade interior shown.

Luxury accommodation

Inside Hilux's cabin, you'll find car-like refinement almost unheard of in a hard-working utility vehicle. Dampening materials are integral to the cabin frame, keeping the sound of the engine to an absolute minimum and, on the outside, a raked windscreen and shaped outer door mirrors have been specially designed to reduce wind noise. The end result? A comfortably quiet driving experience that you'll savour every time you get behind the wheel.

The Hilux's interior is spacious, too, with plenty of room to spare. In the Hilux Double Cab, it's particularly noticeable as the rear seats can be tipped up in a second to provide instant cargo storage. Additional convenience features include wide opening doors and integral grab handles, granting easy access to both driver and passengers.

1. Increased rear seat width

In the Hilux Double Cab, rear seats come in a generous 480 mm width to ensure passenger comfort.

2. Underseat storage

Inside the Double Cab, convenient extra storage can be found thanks to the rear seat's easy-to-use tip up/recline function.

3. Door pockets

Large door pockets are able to accommodate bigger items and incorporate a bottle holder.



Dual front airbags
For increased safety, Hilux is equipped with two SRS front airbags as standard.

Left-hand drive vehicle shown for illustration purposes only.

A strong protector

Toyota has always been committed to safety. So, in addition to the Hilux's tough, robust build, you'll also find a range of active and passive safety features as standard, with dual front airbags, ABS and halogen headlamps among them. Additionally, Hilux's Automatic Disconnecting Differential (available on HL₃ and Invincible) saves wear and tear on the forward axle by automatically disconnecting power to the front wheels when driving in 2WD mode.

All these tried-and-tested technology features combine with a vehicle that's engineered to withstand the toughest challenges imaginable. So whether you're going on the road or off, Toyota Hilux gives you all the reassurance you need.

ABS
Anti-locking Braking System (ABS) helps prevent wheels from locking up when braking on a slippery road by electronically balancing the braking force between all four wheels to match the level of grip of each one.

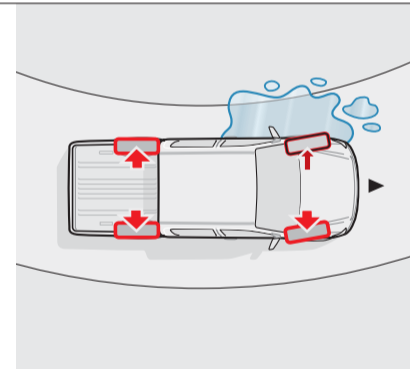

LSPV
Toyota's Load Sensing Proportioning Valve optimises braking performance in direct response to Hilux's payload, increasing rear-brake pressure when the vehicle is loaded.

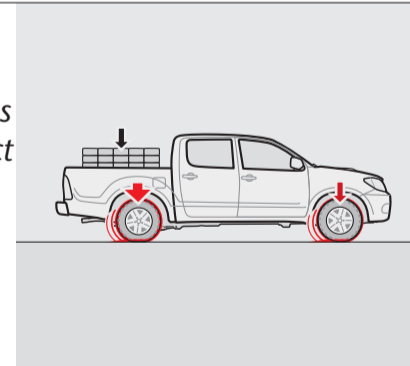

Front disc brakes
Ventilated front disc brakes provide well-controlled, high-performance braking.



Halogen headlamps
Hilux's projector style headlamps deliver exceptional light patterns on dark roads, making night-time driving substantially safer.



Seat belts
Front and rear outer seat belts with three-point Emergency Locking Retractor (ELR) help reduce the risk of chest injuries in an accident.

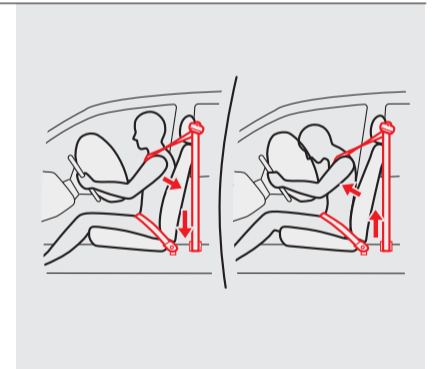

GOA body structure
Hilux's occupants are protected by a class-leading Global Outstanding Assessment (GOA) body structure, designed to effectively absorb shocks and distribute impact forces throughout the whole frame at the same time in the event of collision.

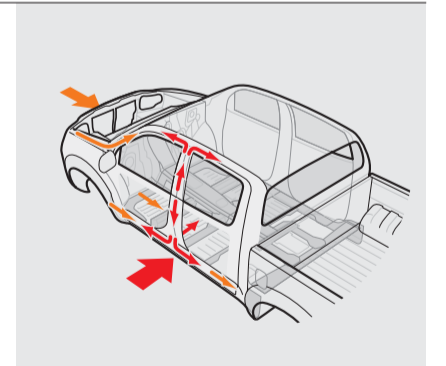

Available in three tempting grades



Shown with optional leather seats.

HL₂

With the Hilux HL₂, you can really enjoy unbreakable ability in style. On the outside, there's an unpainted front bumper and black rear step for Single Cab models (Double cab has a painted front bumper and no rear step), black door handles and mirrors, and 16" steel HL₂ wheels (15" on 4x2 model). Single Cab has useful lashing hooks on the outside of the load deck, whilst all HL₂ models have a cab protection guard/ladder rack.

Inside, the toughness continues, with a hard-wearing fabric trim and matching fascia throughout. To enhance your driving pleasure even further, Hilux HL₂ also offers manual air conditioning as standard for added comfort as well as a single MP3 CD radio system (4-speaker for Double Cab) to keep you entertained on any trip.

The Hilux HL₂ – for wherever you're going.

HL₃

The Hilux HL₃ gives that little bit more luxury on an already substantially refined vehicle. Aesthetically pleasing overfenders are standard, as is a radiator grille in the body colour along with plated-chrome moulding. Chrome door handles complement chrome, electric mirrors. Chrome rear step, alloy side steps and chunky 15" alloy wheels complete the styling package. As for the interior, the HL₃'s velour fabric matches the silver dashboard inserts beautifully. Power windows and manual air conditioning provide a little extra indulgence. And to keep you fully entertained, there's a 4-speaker, MP3 CD audio system with DSP sound processing and a Liveliness Enhancing Filter (LEF) for more powerful high and low tones. This will play either regular CDs or MP3 CD-Rs.

Invincible

The Hilux Invincible is high on styling and tactile comfort. Quite simply, nothing compares. 16" metallic finish alloys, stainless steel side running bars, front fog lamps and rear privacy glass make the exterior stand out dramatically. Six-CD autochanger and tape tuner audio system offer maximum entertainment, whilst the leather shift lever and steering wheel ensure you have all the necessary comforts.

The Hilux Invincible – rugged styling, practical luxury, unbreakable build.



HL₂ mirror
The door mirrors on the HL₂ grade are in practical black.



HL₂ front bumper
Robust styling adds to the Hilux's appeal.



Manual air conditioning
For added cabin comfort, manual air conditioning comes as standard.



15" steel wheel
The 4x2 HL₂ Hilux has 15" steel wheels as standard.



16" steel wheel
For the 4x4 HL₂ Hilux, 16" steel wheels are standard.



15" alloy wheel
The HL₃ grade is distinguished by its standard alloy wheels.



Chrome bumper
A chrome rear bumper is standard on the HL₃ grade.



Chrome exterior mirror
The chrome door mirrors are electrically operated. (HL₃ and Invincible grades.)



Power windows
The power windows have a one-touch down function on the driver's side.

Choice is no obstacle

With the Toyota Hilux you can add your own personal touch. Take your pick from six colours and three grade trims.

040 Pure White



1C0 Silver Steel*



3E5 Sunburst Red



6S3 Kielder Green*



8P1 Balearic Blue*



8P4 Carlo Blue*



* Metallic paint.

15" steel wheel
Standard on the 4x2 HL₂ Single Cab.



15" alloy wheel
Standard on the HL₃ grade.



16" steel wheel
Standard on the 4x4 HL₂ Grade in all body styles.



16" alloy wheel
Standard on the Invincible grade.



Toyota Hilux HL₂ trim.



Toyota Hilux HL₃ and Invincible trim.



Optional leather trim.

EXTERIOR COLOURS

	Double Cab	Single Cab
040 Pure White	•	•
1C0 Silver Steel*	•	•
3E5 Sunburst Red	•	•
6S3 Kielder Green*	•	•
8P1 Balearic Blue*	•	•
8P4 Carlo Blue*	•	•

Specifications

ENGINE

	4x2 2.5 litre D-4D diesel	4x4 2.5 litre D-4D diesel
Engine code	2KD-FTV	2KD-FTV
Number of cylinders	4 in line	4 in line
Valve mechanism	16-valve DOHC	16-valve DOHC
Fuel injection system	Direct Injection common rail	Direct Injection common rail
Displacement (cc)	2494	2494
Bore & stroke (mm)	92.0 x 93.8	92.0 x 93.8
Compression ratio	18.5:1	18.5:1
Maximum output (kW/rpm)	75/3600	75/3600
Maximum torque (Nm/rpm)	200/1400–3400	260/1600–2400
Drag coefficient	0.37	0.37

SUSPENSION

Front	Double wishbone with coil springs
Rear	Leaf springs with twin tube shock absorbers

TYRES AND WHEELS

LHD	Single Cab		Double Cab		
	4x2 HL ₂	4x4 HL ₂	4x4 HL ₂	4x4 HL ₃	4x4 Invincible
15" steel wheels w/205/70R15 tyres	•	–	–	–	–
16" steel wheels w/205/70R16 tyres	–	•	•	–	–
15" alloy wheels w/255/70R15 tyres	–	–	–	•	–
16" alloy wheels w/255/65R16 tyres	–	–	–	–	•

BRAKES

Front	Ventilated discs
Rear	Leading-Trailing Drums

TRANSMISSION

	HL ₂	HL ₃	Invincible
Gearbox type	5 M/T	5 M/T	5 M/T
Drive type	4x2 or 4x4	4x4	4x4

DIMENSIONS

	Single Cab HL ₂ 4x2	Single Cab HL ₂ 4x4	Double Cab HL ₂ 4x4	Double Cab HL ₃ 4x4	Double Cab Invincible 4x4
Dimensions					
Overall length (mm)	5255	5255	5130	5255	5255
Overall width excluding mirrors (mm)	1760	1835	1835	1835	1835
Overall height unladen (mm)	1680	1795	1810	1810	1810
Wheelbase (mm)	3085	3085	3085	3085	3085
Front tread (mm)	1510	1540	1540	1540	1540
Rear tread (mm)	1510	1540	1540	1540	1540
Minimum turning circle kerb to kerb (m)	11.8	12.2	12.2	12.2	12.2
Minimum turning circle wall to wall (m)	12.6	13	13	13	13
Deck Space					
Deck height from ground unladen (mm)	745	860	850	850	850
Internal deck height (mm)	450	450	450	450	450
Internal deck width (mm)	1520	1520	1515	1515	1515
Internal deck length (mm)	2315	2315	1520	1520	1520
Width between wheel arches (mm)	1100	1100	1100	1100	1100
Weights					
Kerb weight (kg)*	1600	1790	1865	1865	1865
Gross vehicle weight (kg)	2770	2735	2950	2950	2950
Max. payload (kg)*	1170	945	1085	1085	1085
Axle load limit, front (kg)	1200	1300	1300	1300	1300
Axle load limit, rear (kg)	1830	1680	1680	1680	1680
Roof load limit (kg)	–	–	75	75	75
Towing Capacity					
Braked trailer weight (kg)	1800	2250	2250**	2250**	2250**
Unbraked trailer weight (kg)	750	750	750	750	750
Max nose weight on tow ball (kg)	92	110	110	110	110
Gross train weight (kg)	4570	4985	5200**	5200**	5200**

* Kerb weight and max. payload include a full tank of fuel and all fluids. They exclude driver, passengers and other added accessories.

All kerb masses quoted are subject to manufacturing tolerances and are for vehicles with minimum equipment.

§ 5130 mm HL₂ Double Cab with no rear step.

¶ 1760 mm HL₂ grades.

** Final towing capacity is subject to final homologation and may change. Check with your Toyota Business Centre.

Please note: all width measurements given exclude door mirrors.

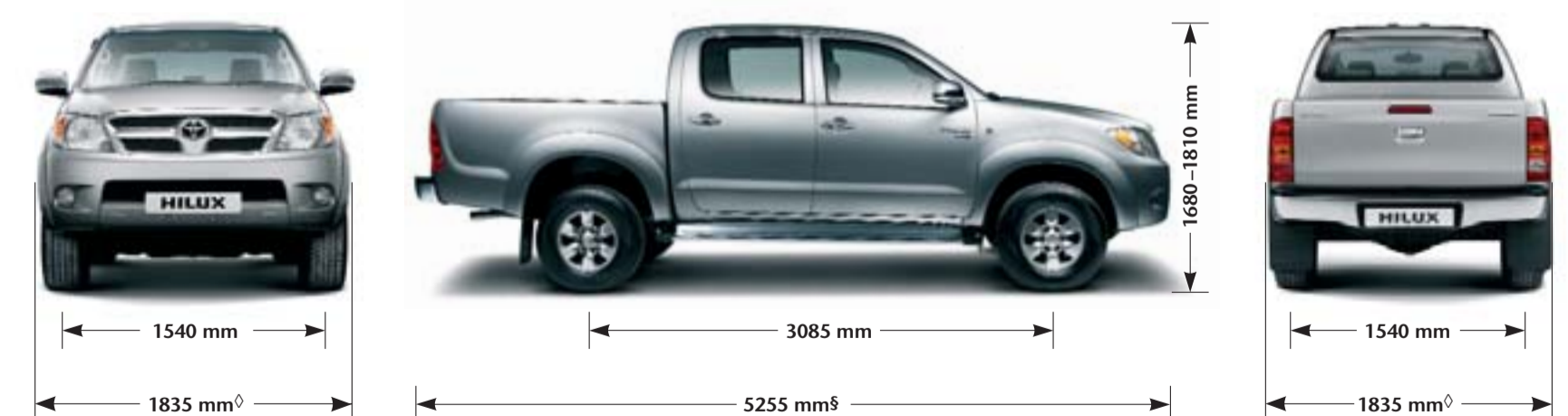

Equipment

EXTERIOR

	Single Cab		Double Cab		
	4x2 HL ₂	4x4 HL ₂	4x4 HL ₂	4x4 HL ₃	4x4 Invincible
Monotone body colour	•	•	•	•	•
Front bumper: material colour	•	•	–	–	–
Front bumper: colour-keyed	–	–	•	•	•
Rear bumper: material colour	•	•	–	–	–
Chrome-plated rear bumper	–	–	•	•	•
Side steps	–	–	•	•	–
Radiator grille: material colour	•	•	–	–	–
Radiator grille: colour-keyed	–	–	•	–	–
Radiator grille: colour-keyed & chrome plated moulding	–	–	–	•	•
Overfenders: colour-keyed	–	–	–	•	•
Front and rear mud flaps	•	•	•	•	•
Door handles: black	•	•	•	–	–
Door handles: chrome	–	–	–	•	•
Door mirrors: black	•	•	•	–	–
Door mirrors: chrome and electric	–	–	–	•	•
Exterior deck lashing hooks	•	•	–	–	–
Cab protector/ladder rack	•	•	•	–	–
Scuff plates	–	–	•	•	•
Front fog lamps	•	•	•	•	•
Chrome tubular side bars	–	–	•	•	•
Rear privacy glass	–	–	–	–	•

COMFORT

Manual air conditioning	•	•	•	•	•
Steering column with manual tilt	•	•	•	•	•
Power steering	•	•	•	•	•
4-spoke steering wheel	•	•	•	•	•
Silver painted insert on center cluster	–	–	–	•	•
Power door lock	•	•	•	•	•
Wireless door lock	•	•	•	•	•
Power window with auto down: D	•	•	•	•	•
Rear window defogger	–	–	•	•	•
In-time adjust & mist wipers	•	•	•	•	•
Assist grips	• (FR 1)	• (FR 3)	• (FR 3)	• (FR 3 & RR 2)	• (FR 3 & RR 2)
Door armrest	•	•	• (FR & RR)	• (FR & RR)	• (FR & RR)
Door pocket	•	•	• (FR & RR)	• (FR & RR)	• (FR & RR)
Console box with lid	•	•	–	–	–
Console box with lid & rear cup holder	–	–	•	•	•
Tachometer	•	•	•	•	•
Clock	•	•	•	•	•
Leather gear shift and transfer knob	–	–	–	–	•
Leathered steering wheel	–	–	–	–	•

AUDIO

	Single Cab		Double Cab		
	4x2 HL ₂	4x4 HL ₂	4x4 HL ₂	4x4 HL ₃	4x4 Invincible
2 speakers	•	•	•	–	–
4 speakers	–	–	•	•	•
Single CD with MP3 CD-R compatibility	•	•	•	•	–
6-disc in-dash autocharger and tape tuner	–	–	–	–	•
TNS310 satellite navigation system and ETA with single CD player	•	•	•	•	•

4x4 TECHNOLOGY

Rear differential	•	•	•	•	•
Auto disconnect differential	–	–	–	•	•
Rear diff lock	–	•	•	•	•
4WD transfer lever & knob	–	•	•	•	•

SAFETY

ABS	•	•	•	•	•
SRS airbags (w/o cut off switch): D & P	•	•	•	•	•
Seat belts with 3-point ELR & pre-tensioners: FR & RR outside	• (FR only)	• (FR only)	•	•	•
Headlamp levelling device	•	•	•	•	•

SECURITY

Immobilizer	•	•	•	•	•
TVSS perimeter alarm	•	•	•	–	–
TVSS perimeter and volumetric category 1 alarm	–	–	–	•	•

SEATS

Front separate seats	•	•	•	•	•
Rear seat with tip-up function	–	–	•	•	•
Seat material: hard-wearing fabric	•	•	•	–	–
Seat material: luxury velour fabric	–	–	–	•	•
Full leather interior	–	–	–	•	•

D = Driver P = Passenger • = Standard • = Optional – = Not available FR = Front RR = Rear

Drive Plans from Toyota Financial Services



We want to make acquiring and maintaining your Hilux as easy as driving one. Our range of Drive Plans has been designed specifically with this in mind, to offer you a choice of affordable ways to finance, service and maintain your new car. Above all, our plans offer flexibility, easy budgeting and peace of mind and can be arranged as a one-stop-shop when you select your Hilux.

As part of the Drive Plans range we have developed several customised schemes, based on specific customer requirements. These Drive Plans are:

Hire Purchase Drive Plans

A Hire Purchase Drive Plan provides an original, simple and effective finance package. This plan allows you to drive the car of your choice and spread the payments over an agreed period to suit you, with fixed monthly payments allowing for easy budgeting.

Lease Purchase Drive Plans

This is a product for business users that is particularly useful for non-VAT-registered businesses as monthly charges are exempt from VAT.

The initial capital outlay is reduced since the vehicle is given an anticipated future value, the payment of which is deferred to the end of the agreement. This allows for lower monthly payments that are fixed over the agreed period.

Business Drive

Business Drive offers the security of a fully maintained Contract Hire package, ideally suited for VAT registered businesses. The package offers a host of benefits including reduced capital outlay, all-inclusive monthly rentals and no depreciation, disposal or administration problems.

Flexible Finance

However, Drive Plans are about more than just these schemes. Whatever your needs, Toyota has a full range of finance options to offer you. Whether you're a private motorist or a business customer, just discuss your individual requirements with your Toyota Centre, who will be pleased to help you choose a Drive Plan to suit you.



Customer services

Club Toyota

When you buy a Toyota you automatically become a member of Club Toyota for 12 months free of charge. This entitles you to take advantage of a host of benefits including free RAC Roadside Assistance in the UK and Europe, 5% discount on Toyota Insurance for your car and specially negotiated rates for travel insurance, plus exclusive offers and promotions through our quarterly customer magazine.

Toyota Drive Plans

Toyota Drive Plans make acquiring and maintaining your new car as easy as driving it. They offer a choice of affordable ways to help you buy, finance, service and maintain your Toyota. The range of plans has been structured to offer you flexibility, easy budgeting and peace of mind.

- Easy Start is an exciting new low-deposit plan.
- Easy Care offers the complete reassurance of prepaid servicing.
- Easy Drive is a comprehensive plan that takes care of most of your motoring needs for two to three years with one monthly payment.
- Business Drive is a fully maintained Contract Hire package most suited to small business customers.

Whatever your personal preference, your Toyota Centre can tailor a Drive Plan to suit your needs perfectly – driving a new car has never been so easy. Written quotations available on request. All agreements subject to status. Indemnities may be required.

Toyota Insurance

Toyota Insurance is available for Toyota owners at competitive premiums. To obtain details of the benefits included and to arrange a quotation, please contact your local Toyota Centre or call 0800 350 500.

Licensed credit broker. Indemnities may be required. All finance subject to status to over 18's only. Toyota Financial Services (UK) PLC, Great Burgh, Burgh Heath, Epsom, Surrey, KT18 5UZ. Toyota Financial Services is authorised and regulated by the Financial Services Authority.

Toyota Fleet

Toyota Fleet provides complete business solutions for companies that run a fleet of vehicles. For more information on how Toyota Fleet can deliver your fleet requirements, either contact your local Toyota Centre or the Toyota Fleet Business Centre on 0845 271 2712. (Calls to Toyota may be monitored or recorded to improve customer service.)

Toyota Warranties

Every new Toyota comes with a 3-year/60,000-mile manufacturer's warranty, covering your car against the unlikely event of a manufacturing defect causing a mechanical fault. It includes coverage for paint and surface rust for three years unlimited mileage and a 12-year anti-perforation warranty. After the initial warranty period has ended, you can choose to extend your warranty until the vehicle is seven years old – choosing from a range of packages to suit your vehicle and your needs. All of our warranties cover the main component parts of the vehicle*, meaning that you pay for nothing beyond routine servicing and maintenance, so there are no unexpected bills to pay.

Toyota Accident Assistance

Toyota provides a comprehensive accident management service for all Toyota drivers, giving advice, assistance and practical help free of charge in the event of an emergency.

Toyota Approved Used cars

All Toyota Approved Used vehicles come complete with an RAC pre-check delivery, a mileage check, a free 600-mile or one-month inspection, 12 months' Club Toyota membership and a 14-day no-quibble exchange plan.

* With the exception of batteries, corrosion of exhaust and damage or wear to the interior.

For more information about end-of-life vehicles, please refer to www.toyota-europe.com



The pulp used in this paper is chlorine free and comes from sustainable sources. Please refer to www.toyota.co.uk for further environmental information.

Whilst every effort is made to reproduce accurate information, we reserve the right to change specifications, equipment and availability without prior notice. This brochure cannot be regarded as infallible, (some of the vehicles shown may not be to exact UK specification), and as such does not constitute an offer for sale of any particular vehicle or specification. Fuel consumption values quoted throughout this brochure are determined according to EC Directive 1999/100/EC. The results do not express or imply any guarantee of actual fuel consumption. For the latest specification and availability we ask that you contact your local Toyota Centre.



Hilux carries complete peace of mind too

Hilux has been engineered to give a great driving experience, regardless of the conditions. But the ownership experience is made even more rewarding through the peace of mind afforded by Toyota's global reputation for quality and integrity.

Hilux provides an exhilarating driving experience. And an outstanding ownership experience. Toyota's global reputation for quality and integrity means Hilux can add peace of mind to its list of attributes.



Car recycling

Taking care of the environment is a priority for Toyota. We're making a huge effort to ensure that during the life-cycle of our vehicles – from design, production, distribution, sales and service to end-of-life – their environmental impact is minimised. You can find detailed information on Toyota's environmental performance at www.toyota-europe.com/environment. In addition, your Toyota retailer will be happy to provide more information on end-of-life vehicle requirements.

Intelligent design

The Hilux is designed and engineered to minimise the maintenance overhead. There are fewer parts that require servicing and those that do are inherently durable to extend service intervals. Equally important is that Hilux technology is made easily accessible so that maintenance labour time can be minimised. These features combine with the highly competitive pricing of Toyota spares to ensure the lowest cost of maintaining your Hilux in an ideal working condition.

Toyota quality service

Your Toyota retailer will talk you through the Hilux 'Health and Safety' maintenance programme. The programme is very straightforward and designed for your convenience. In effect, your Hilux needs a full Health and Safety check, dependant on driving style and conditions, up to once every two years or 20,000 miles (whichever comes sooner). An intermediate Health and Safety check is necessary every year or 10,000 miles.

Toyota warranties

We are confident that every Hilux is so well built that each car comes with a three-year or 60,000 mile vehicle warranty covering any mechanical failure. In addition, the paintwork, no matter which colour you choose, is also guaranteed against imperfections for three years (one year for the deck panel). Finally, the body as a whole is guaranteed for six years against corrosion perforation (three years for the deck panel).

Toyota genuine parts

The Hilux is designed to minimise the cost of accident repair. Energy-absorbing elements are built into the bumpers, expensive-to-replace parts are located away from damage zones, and commonly damaged body parts are bolted rather than welded. As a result, the extent of damage is limited and damaged parts are easy to remove, replace or repair. Ultimately, this means very low part and labour charges.

Toyota Eurocare

In order to help you enjoy peace-of-mind driving, we are pleased to provide three years' Toyota Eurocare roadside assistance coverage in no less than 30 European countries. If you experience a problem with your Hilux, Toyota Eurocare offers several possibilities to keep you on the road.

Added security

The Hilux's security system withstands the insurance industry's rigorous five-minute attack test and provides excellent protection. Both the alarm system and engine immobiliser are approved by Europe's major insurance companies.

Toyota accessories

Toyota accessories are designed and manufactured with the same care, quality and attention to detail as Toyota vehicles. Tailor-made for your Toyota, they fit perfectly and add a personal touch of style, comfort or practicality. And because they've been tested under the most severe conditions, you can have complete confidence in their reliability and durability. To add to the reassurance, every genuine Toyota accessory has a three-year warranty.*

* Check with your Retailer for specific warranty details.

Hilux Accessories

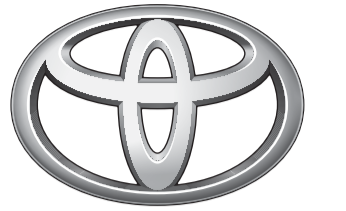

TOYOTA



As individual as life itself

Life takes on a new dimension with the Toyota Hilux. Its strength, versatility, passenger-car sophistication and dynamic good looks open a world of endless possibilities.

Toyota accessories extend flexibility even further by providing those special touches of pure individuality to reflect your own taste for extra style, comfort and practicality.

Importantly, all the accessories in the range are designed and made with the same care and attention to

detail as the Hilux itself. Toyota accessories are developed by Toyota uniquely for Toyota cars. Similarly, accessories from our approved partners meet similar standards of performance and purpose. As a result, whichever accessories you choose, installation is easy, integration is perfect and you have the absolute assurance of superior quality, functionality and reliability.

Wherever you're going, whatever life holds in store, with the Hilux and Toyota accessories, you can get there and enjoy the experience in a way that's sure to suit you best.

Hi-over Sports bar

The perfect example of personal expression. Made of stainless steel and with a bright chrome finish, it fixes just behind the cab to create a superb visual highlight.

Roof rack

For large or bulky loads a genuine Toyota roof rack is available, Double Cab only. (Shown with optional sailboard/mast holder.)



Side steps

Complement your car's rugged good looks while also offering the practical advantage of making passenger access easier.

Wind deflectors

Toyota wind deflectors allow fresh air into the cabin but avoid draughts.

Front fog lamps

When the weather turns murky, front fog lamps are an invaluable safety aid, standard on Invincible.

Assert your individuality

With Toyota's specially designed range of quality accessories, you can express your personality and make your Hilux even more distinctive.

Whether you choose for style, comfort or convenience, you can be assured that all parts meet the high standards of performance and reliability for which Toyota is renowned.

Audio

Active subwoofer (fits under seat)
Tweeters (located in 'A' pillars)

Body exterior

Front guard including silver finish under guard (can be painted)
Front under guard – silver finish (available separately to above front guard)
Hi-over Sports bar (chromed stainless steel) – HL₂ (can be fitted with ladder rack), HL₃, Invincible front cover
Hi-over Sports bar and under rail inner bed liner* – **must be specified at point of vehicle order**
– Double Cab models
Side bars (tubular stainless steel) – HL₂, HL₃
Side steps (aluminium) – Double Cab models
Wind deflectors for front windows only

Convenience

Bluetooth® Hands Free system
Cool/hot bag, grey/black
Toyota Hands Free kits:
THF15 – base kit, THF25 – premium kit & THF35 – pro kit
Toyota Parking Aid, 4-sensor system (TPA 400)* & 8-sensor system (TPA 800) – except HL₂ 4x4 Double Cab
Turn-by-turn navigation system (TNS310)
Above navigation system plus ETA
– **must be specified at point of vehicle order**

Emergency

Emergency kit, comprising warning triangle and first-aid kit in zipped holdall*
Fire extinguisher*
First aid kit*

Interior trim

Carpet mats, Premium grey textile – Double Cab models
Carpet mats, Standard grey textile – Double Cab models*
Leather interior, Basalte grey – **must be specified at point of vehicle order** – HL₃, Invincible front cover
Rubber mats, front set – Single Cab models*
Rubber mats, full set – Double Cab models
Scuff plates, front set – Double Cab models
Shift knob, grey leather – 2WD models
Shift knob, grey leather, set of two – 4WD models

Lights

Driving lamps, grille mounted
Front fog lamps (standard on Invincible)

Accessories applicable to all models unless otherwise stated. Some products listed may not be available at launch of the vehicle and will be introduced January 2006.* Not illustrated.

Load space

Deck bed liner, black (fits over rail)
Hard tonneau cover with Sports bar (lockable, can be painted) – HL₃, Invincible
Mountain Top aluminium bed liner
Mountain Top aluminium tonneau cover
Mountain Top bed x-tender
Mountain Top bedrug liner – Double Cab models
Mountain Top roll 'n lock – HL₃, Invincible
Sammitr truck top – Double Cab models
Snugg leisure & commercial truck tops
Truckman commercial truck tops*
Tonneau cover, soft polyester 680 g/m²
Under rail inner bed liner – Double Cab models

Locks

TRACKER Stolen Vehicle Tracking systems – Retrieve, Monitor & Horizon

Roof

Roof rack (load capacity 75 kg) – Double Cab models only
The following accessory holders can be fitted with the above Roof rack:
Barracuda bicycle carrier – holds one bike, three can be fitted
Canoe holder*
Luggage box*
Luggage platform*
Ski box* (requires mounting kit)
Ski holders*
Sailboard/mast holder

Safety

Child restraint seat, baby safe G0+, approx. up to 15 months (up to 13 kg)
Child restraint seat, G1 Duo Plus, approx. 8 months to 4 years (9–18 kg)
Child restraint seat, kid G3, approx. 3–12 years (15–36 kg)*

Storage

Coat hanger – Double Cab models
Seat storage bag, beige/black or grey/black
– Double Cab models

Towing

Rear bicycle holder for two bicycles, option of third bicycle extension, must be fitted with tow bar and lighting system
Tow bar, detachable (max. tongue load 90 kg) – 4x2 models
Tow bar, flanged (max. tongue load 120 kg) – 4x4 models
Ball and hitch for flanged tow bar

Wheels

Ozark – 15" alloy wheels, tyre size required
255/70 R15C – 4x4 models front cover
Zagros – 15" alloy wheels – 4x2 models
Locking wheel nuts
Spare wheel lock



Making more of the appeal

There's no denying the rugged appeal of the Hilux. Add Toyota style accessories and you'll create even more of an impression.

Alloy wheels present an ideal opportunity to express your individuality. For your Hilux there are two 15" designs to choose from. Both have been especially conceived to complement the look of the Hilux and then quality made to be lightweight, strong and very durable. Protect your new alloys from theft with locking wheel nuts.

A front guard extends the style even further. Made of black soft-feel polyurethane, it emphasises the sturdy appearance of the front-end of your car. The guard can be painted to match the Hilux's original body colour and includes a silver finish under guard and a chrome finish upper garnish to complete those all important visual details.

If you prefer a slightly more subtle look, you can fit the under guard only. This has a silver finish and combines perfectly to enhance the robust feel of the original Hilux front bumper.

1. Under guard.

2. Alloy wheels, Zagros 15" – 4x2 models.

3. Alloy wheels, Ozark 15" – 4x4 models.

4. Front guard (with under guard).

Accessories applicable to all models unless otherwise stated.





1.

Your choice for style

Details make the difference when it comes to style. Toyota accessories offer the flexibility to show exactly how you like things to be.

A hi-over bar is the perfect example of personal expression. Made of stainless steel and with a bright chrome finish it fixes just behind the cab to create a superb visual highlight. Importantly, the design and installation is fully compatible with the Toyota bed liner.

In a similar vein, chrome finish stainless steel side bars expertly blend with the shape and stature of the Hilux to emphasise its go anywhere appeal. Alternatively, you can choose aluminium side steps. These equally complement your car's rugged good looks while also offering the practical advantage of making passenger access easier.

Front driving lamps complete the picture of style and adventure. They operate when you switch to high beam and provide powerful additional illumination to enhance night-time and bad weather visibility.

Accessories applicable to all models unless otherwise stated.



2.

1. Hi-over chromed stainless steel Sports bar.
2. Driving lamps.
3. Aluminium side steps – Double Cab only.
4. Tubular, stainless steel side bars – HL₂ & HL₃, Double Cab only.



3.



4.



A look of luxury

A tailored leather interior adds that unmistakable air of luxury to the inherent high quality cabin of your Toyota Hilux.

For HL3 and Invincible Double Cab models, the great news is that a genuine Toyota leather interior can be fitted. Variations include seat and door panel upholstery and it is available in Basalte grey.

The leather used for Toyota upholstery is carefully selected for quality. Then, throughout manufacture, it is subjected to rigorous inspection to comply with the toughest European standards. As a result you can be sure of its comfort and durability while also having the convenience of being able to simply wipe the surface clean to maintain the look of prestige and elegance.

Detail accessories then enhance the impression even further. Brushed metallic scuff plates for the front doors not only add style but will also protect the sills from day to day marks and scrapes. A leather shift knob, available for both the two and four wheel drive models, provides that final touch to make the whole look complete.

Left. *Leather interior – HL3, Invincible (must be ordered with vehicle).*

1. *Scuff plates (front set) – Double Cab models.*

2. *Leather gear shift knob – 2WD models.*

3. *Leather gear shift knobs – 4WD models.*

Accessories applicable to all models unless otherwise stated.





1.



2.



5.



3.



4.



6.

In touch with your world

Toyota makes technology easy. Satellite navigation, Hands Free phone systems and top quality audio will keep you connected wherever you go.

Finding your way is simple with the innovative Toyota TNS310 DVD navigation system. Directions are provided in audio and as on-screen graphics. You get ultra-fast route and alternative route calculations. All maps are located on a single DVD disc. And the memory is packed with useful information such as tourist spots and service

stations. You can also add the optional Electronic Traffic Avoidance (ETA) function for traffic warnings and automatic re-routing around notified problems. The TNS310 with ETA DVD navigation system integrates with Toyota wide 2 DIN single CD player and must be specified at point of ordering your vehicle.

Equally easy to use is the Hands Free telephone kit. Simply clip your phone* into the cable-less cradle and you can start using it straightaway. The cradle is interchangeable, which means you can take it and your phone to use in another car fitted with the same

system. Also, when you upgrade your phone, you only need change the cradle and not the whole system. A choice of occasional, business and executive versions increases flexibility even further.

Toyota also offers an advanced mobile phone solution featuring voice recognition commands for users of phones compatible with Bluetooth® wireless technology. The system incorporates a backlit dashboard keypad control, connects to your audio for enhanced sound quality and has a directional microphone to maximise pick-up.

Conveniently, the speaker-independent voice recognition function enables voice commands for dialling up to 20 regular number. For added versatility, four different Bluetooth® compatible phones can be paired with the system at the same time.

* Please contact your local Toyota Centre for details of mobile phone compatibility.

Accessories applicable to all models unless otherwise stated.



1.



2.



3.



4.



5.



6.

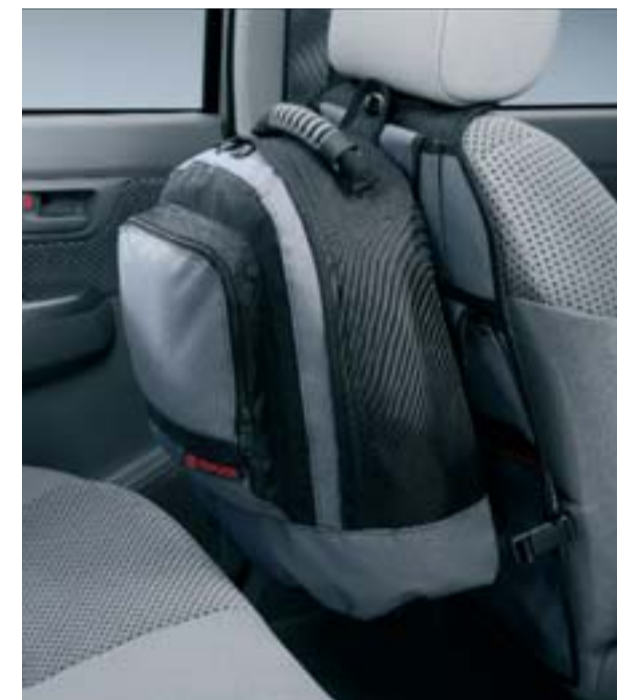

7.



8.



9.

Adding to the adventure

The Hilux has an almost legendary 'go anywhere' capability. Toyota accessories add even more carrying capacity to enhance the spirit of adventure.

You have a choice of either detachable or flanged tow bars. Each is suitable for use with or without a rear bumper and can be supplied with a dedicated wiring kit.

If cycling is your passion, the rear bicycle holder will fix to either type of tow bar and can hold up to three bicycles when combined with a separate extension.

For maximum flexibility, the aerodynamic, aluminium, lockable roof rack provides the ideal solution for Double Cabs. It is easy to install and can be combined with a great range of optional attachments. The attachments include a luggage platform, canoe and sailboard holders, a bicycle holder and two sizes of ski holders. There are also a streamlined designed ski box and a luggage box, both feature central locking and passenger side opening. For inside the

cabin the range includes a seat-back storage bag with detachable rucksack section, seat-back coat hanger and a high capacity cool/hot bag that plugs into your car's 12 volt accessory socket and can be used for keeping food and refreshments either piping hot or deliciously chilled.

1. Detachable tow bar with wiring kit – HL₂ 4x2 Single Cab.

2. Flanged tow bar with wiring kit (with under run protector) – 4x4 models.

3. Ball and hitch for flanged tow bar (option).

4. Rear bicycle holder. Holds 2 width extension option for 3rd bike. Must be fitted with tow bar and lighting system.

5. Roof rack with optional Barracuda bicycle carrier – Double Cab models.

6. Roof rack with optional sailboard/mast holder – Double Cab models.

7. Seat storage bag, beige/black or grey/black – Double Cab models.

8. Cool/hot bag – grey/black.

9. Coat hanger – Double Cab models.

Accessories applicable to all models unless otherwise stated.



1.



2.



3.



4.

Protection you can rely on

For parents, protecting younger passengers is perhaps the biggest responsibility of all. That's why Toyota child restraint systems are purpose designed for maximum safety.

The G1 Plus seat is for children of between eight months and four years (approximately 9 to 18 kg). It fixes securely using the standard three-point seat belt and has wide wings for maximum side impact protection.

For babies up to about 15 months (to 13 kg) there's the G0+ Babysafe seat. This is designed to increase side impact protection and also incorporates an adjustable canopy to shield against the sun and wind.

Accessories applicable to all models unless otherwise stated.

The Kid restraint system suits bigger children of between three and twelve years (approximately 15 to 36 kg). Its design consists of two parts: a booster cushion and a backrest featuring deep side wings and a curved head support. The extra height of the 8booster cushion and the precise guides on the backrest ensure correct seatbelt positioning to hold your child firmly but comfortably in place. The system attaches using the seat belt and has a height adjustable headrest (not illustrated).

Protection for your carpets is provided by Toyota tailored fit floor mats. There are rubber mats to maximise protection against the very worst conditions and a choice of velour or needle felt textile mats.

1. G1 Plus child restraint seat.
2. Babysafe G0+ child restraint seat.
3. Rubber floor mats.
4. Premium velour carpet mats – Double Cab models.



1.



2.



3.



4.



5.

Day to day care

The Toyota accessory range provides extra security and protection to care for your car and enhance that 'peace of mind' feeling.

Toyota's parking aid system is a great help in avoiding the bumps and scrapes of city parking or when parking near to low objects. You have a choice of the TPA400 system with four rear sensors or the TPA800 with four rear and four front sensors. When either system is engaged, the sensors link to an interior warning that becomes progressively louder the closer your vehicle gets to an obstacle.

For security when parked you can complement the Hilux's pre-fitted immobiliser with a TRACKER Stolen Vehicle Security system.

Additionally, there's a steel lock for your spare wheel and a set of four locking wheel nuts with a unique coded key for your valuable alloys.

If you like driving with the windows open, Toyota wind deflectors let you enjoy the fresh-air sensation without excessive turbulence and noise. Equally, fog lamps make for safer driving in bad weather and poor light conditions while adding a definite sporty touch to your car's front end styling.

1. Four- and eight-sensor parking aid systems (eight-sensor system illustrated) – except H₂ 4x4. The ultrasonic parking aid system's sensors can be painted to match your car's body colour.
2. Fog lamps.
3. Wind deflectors (front pair).
4. Locking wheel nuts.
5. TRACKER Stolen Vehicle Security systems.





1.



2.



3.



4.

Tough, practical and secure

The Hilux lets you carry almost anything to virtually anywhere. Toyota deck bed accessories make it safer, easier and more secure to do so.

For the Double Cab the hard tonneau cover with its hi-over bar and lockable hinged opening offers a great combination of style and practicality. It can be painted to match your car's body colour for that totally integrated look.

Optimum functionality comes in the form of the lockable aluminium tonneau cover by Mountain Top. It protects items stored within the deck bed and, being made of heavy duty aluminium with in-built rails, it can also be

used to secure items weighing up to 100 kg on its top.

Suitable for Single and Double Cabs the soft tonneau cover is just right for protecting your cargo against the weather and the prying eyes of passing strangers. It is made of durable black polyester and is fully compatible with the deck bed liner.

Easy access and security combine in the ingenious Mountain Top roll n' lock tonneau cover. Conveniently, the system features auto-positioning and locking so that you can secure the cover in a partially or fully closed position. The Mountain Top cargo manager which can be added as an option presents a simple yet highly effective way to prevent your cargo moving about.

Accessories applicable to all models unless otherwise stated.

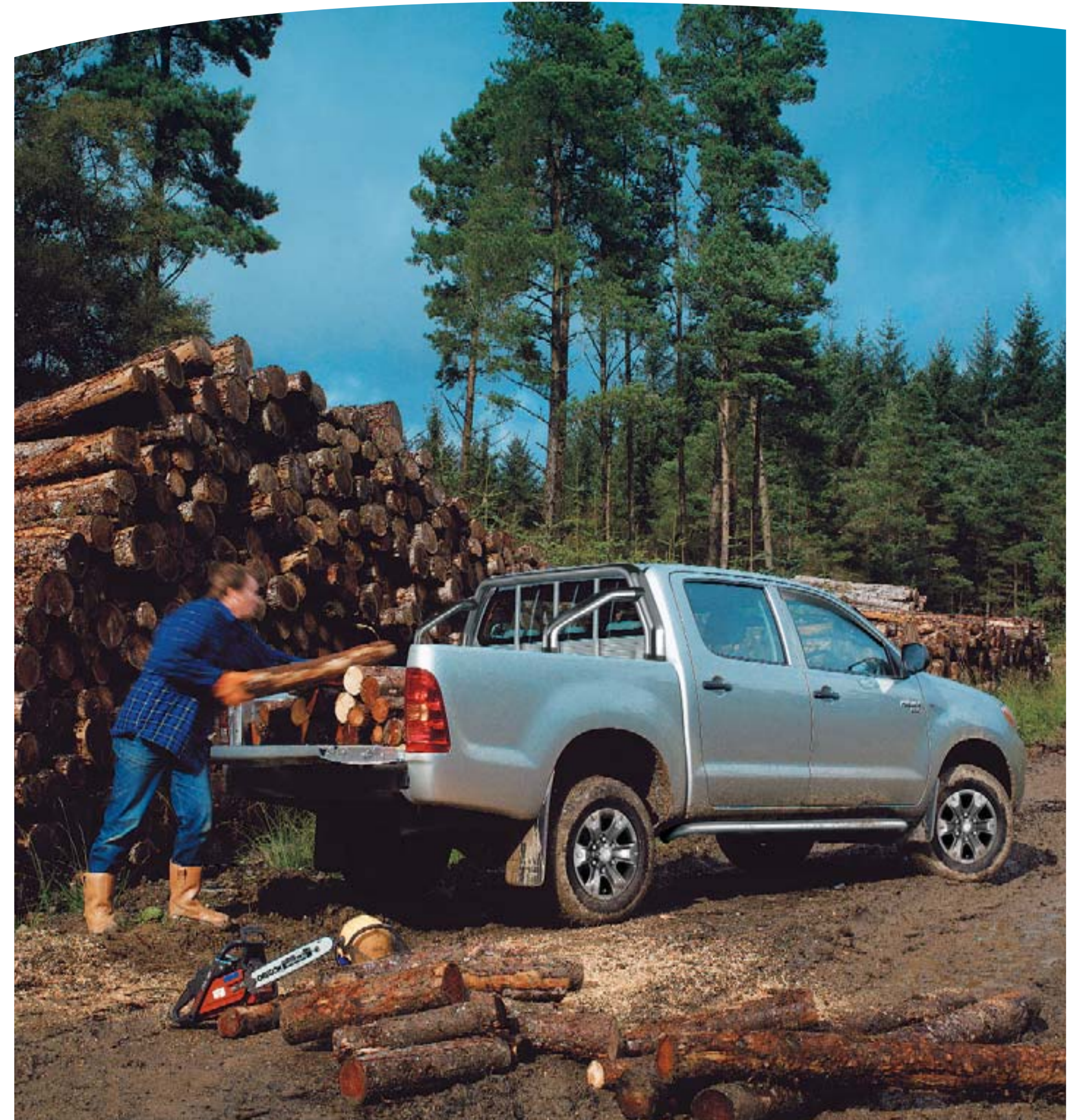

1. Hard tonneau cover with Sports bar – all Double Cab models.
2. Aluminium tonneau cover by Mountain Top.
3. Soft tonneau cover.
4. Roll n' lock tonneau cover by Mountain Top – all Double Cab models.

Above. This vehicle is fitted with Ozark 15" alloy wheels, tubular stainless steel side bars and the hi-over Sports bar*.

* The ladder rack is compatible with the hi-over bar on the HL2.



1.



2.



3.



4.



5.

Extending your deck bed options

The range of deck bed accessories offers you a choice of deck bed liners to protect your car and ideally suit the type of cargo you intend to carry.

The high density deck bed liner is just right for day to day items and is fully compatible with Toyota tonneau covers. Heavier protection comes in the form of the Mountain Top under rail inner bed liner. Made of strong polyethylene (HDPE), it has a non-skid surface and is resistant to UV light, shock, oil and most chemicals.

For those really tough carrying jobs you need the Mountain Top aluminium bed liner. It has ultra-strong polyethylene wheel arch covers and can be combined with the aluminium tonneau cover.

The Mountain Top bed rug gives your deck bed the look and feel of having a conventional car boot carpet. Made of the same material as a hard plastic liner, the bed rug has a fibre surface that is resistant to stains, water, acid, grease, oil and chemicals. The bed rug combines with the tonneau cover to create the ultimate user-friendly enclosed carrying space.

The Mountain Top lightweight, aluminium tube bed x-tender enables you to extend the deck bed so that you can safely transport large items of cargo, and it can be flipped over for use as a deck bed divider to secure smaller items.

1. Deck bed liner.
2. Under rail inner bed liner.
3. Aluminium bed liner by Mountain Top.
4. Bed rug by Mountain Top.
5. Bed x-tender by Mountain Top.

Accessories applicable to all models unless otherwise stated.



Truck top appeal and practicality

A Toyota truck top combines load carrying practicality and cargo protection while giving your Hilux the great looks of a wagon.

There are two distinct Toyota truck tops for you to choose from, both of which are available to match your car's original body colour. Each design is tailor-made for the Hilux and securely clamps into position without the need for drilling or structural modifications.

Accessories applicable to all models unless otherwise stated.

The Snugg polyester truck top is tough and very durable. It is available for the Double and Extra Cab models and has pop-out side windows and integral roof rails. The lightweight construction and clamped fixing method make it easy to remove the truck top if you want the convenience of an open bed for carrying bulky items.

Alternatively, there's the Sammitr steel truck top. This has sliding windows, integral roof rails and a steel rear door for secure integration with the tailgate. The inclusion of a rear window defroster/defogger and rear wiper gives your Hilux wagon-style functionality and convenience.

Main image. The Invincible is fitted with a Sammitr steel truck top.

Right. Snugg polyester truck top.



For more information on any other Toyota models and the location of your nearest Toyota Centre, simply call: 0845 275 5555 (calls to Toyota may be monitored or recorded to improve customer service) or visit our website: www.toyota.co.uk

Toyota (GB) PLC. Great Burgh, Burgh Heath, Epsom, Surrey KT18 5UX

The use of the term 'Toyota Accessories' should not be taken to imply that the products in these accessory pages are actually manufactured by the Toyota Motor Corporation or Toyota (GB) PLC. After Sales Division are continually updating and changing specifications of accessories and reserve the right to do so at anytime without prior notice.

help

Using the navigation bar

A navigation bar is provided at the bottom of each page of this e-brochure to make browsing it easy. Please follow the simple instructions on the right to navigate through this e-brochure.

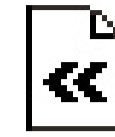

Takes the document back to the beginning.



This will take the document back to the previous page.



This will take the document back to the next page.



Takes the document to the Index page.

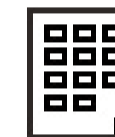

This will allow the Acrobat toolbar to be visible if pressed once and it will also make it disappear if already visible.



This will zoom in on the document so smaller text etc will be easier to read. To zoom in further, click the icon again. If the menu bar is not visible then use your mouse by clicking the left hand button and moving it.



This will zoom out of the document. To zoom out further, click the icon again. If the menu bar is not visible then use your mouse by clicking the left hand button and moving it.



This will print out the full brochure to your printer. Please note that if you have a colour printer this document will print in full colour.



This will save the whole document to your computer.

To close this document press *esc* and then close the document normally.

Whilst every effort is made to reproduce accurate information, we reserve the right to change specifications, equipment and availability without prior notice. This brochure cannot be regarded as infallible, (some of the vehicles shown may not be to exact UK specification), and as such does not constitute an offer for sale of any particular vehicle or specification. For the latest specification and availability we ask that you contact your local Toyota Centre.



home



previous



next



index



show menu



print



zoom in



zoom out



save



help