

Land Cruiser



Toyota Land Cruiser

Contents

Toyota Land Cruiser

Introduction

Models

Land Cruiser LC3

Land Cruiser LC4

Land Cruiser LC5

Land Cruiser Amazon

Comfort

Land Cruiser interior details

Land Cruiser Amazon interior details

Driving

Land Cruiser technology

Land Cruiser Amazon technology

Safety

Finance

Drive Plans

Accessories

Toyota genuine accessories

Colours and trims

Exterior colours and interior trims

Technical data

Glossary

Specifications

Equipment

Peace of mind

Customer services

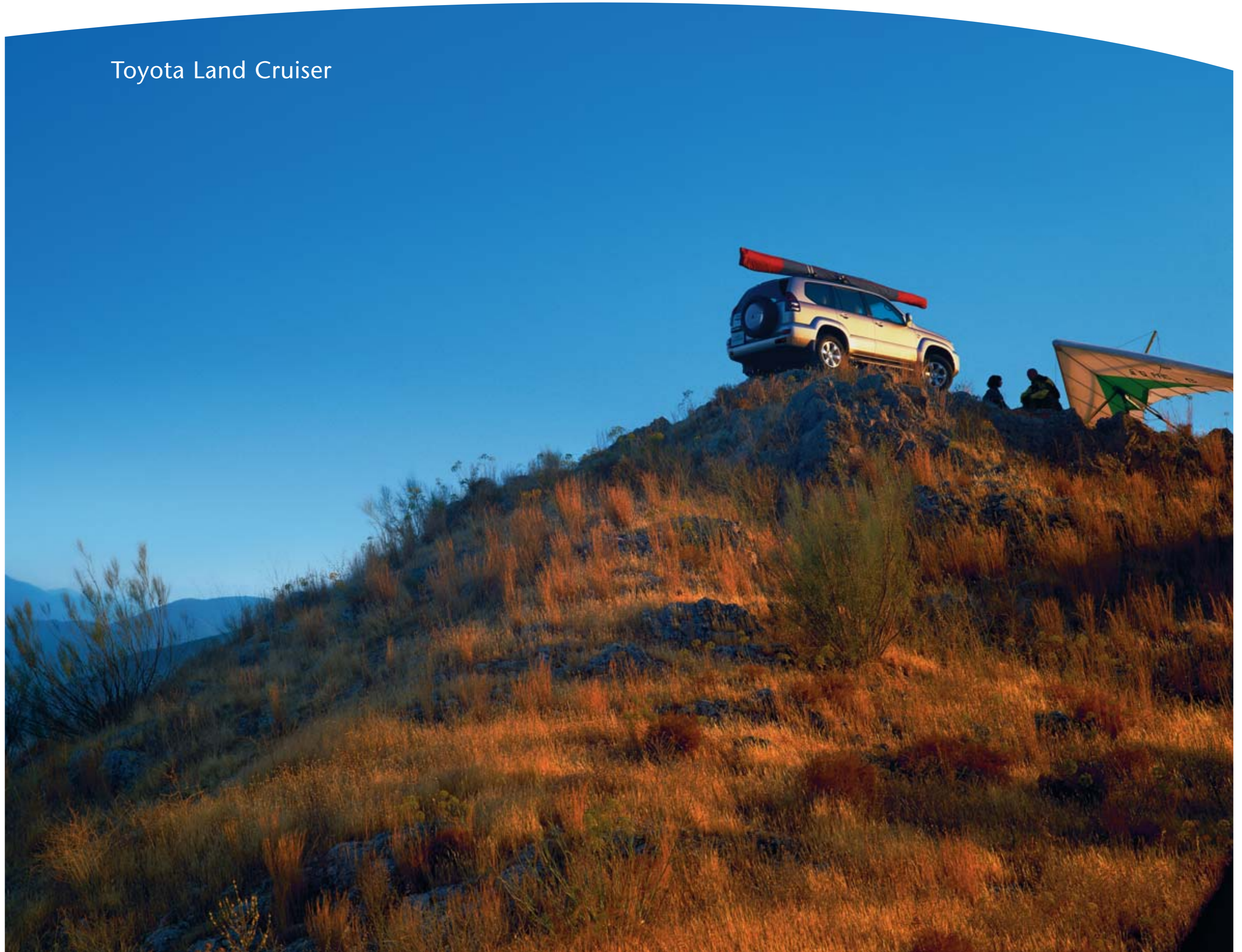

home



previous



next



index



show menu



print



zoom in



zoom out



save



help

Discover the legend



The Toyota Land Cruiser has become a legendary name in the exciting world of 4X4 motoring. And it's easy to see why. For more than 50 years, it has been the name synonymous with technological innovation and the pursuit of excellence.

The Land Cruiser takes some beating. No other Sports Utility Vehicle in its class can match it for off-road performance, power, interior space, safety and technology. Offered with a choice of two powerful engines, the Land Cruiser is available in five- and three-door versions and with three grade levels.

The larger Land Cruiser Amazon is the supreme on- and off-roader, combining practicality, world-beating 'go-anywhere' power and technical innovation. Whether deep in the country or in the heart of the city, it always delivers what it promises – an unrivalled, versatile performance enhanced by the sophistication and comforts of a premium saloon.

Toyota Land Cruiser – the legend just keeps getting bigger.



Land Cruiser three-door



Land Cruiser five-door



Land Cruiser Amazon



Strong presence, strong performance

The Land Cruiser has evolved into one of the best examples of a practical off-roader that combines all the design, characteristics and equipment levels of a quality saloon. Wherever you want to go, it'll take you in comfort and style.

Its mature, powerful presence underlines its inherent off-road capabilities, evidenced by sophisticated full-time 4WD capability. With 'hi-low' transmission options and other technical advancements, it delivers outstanding stability and control – in all weathers and in all driving conditions.

In particular, Torsen limited slip differential provides great off-road control by 'intelligently' splitting the torque between the front and rear wheels, always favouring the wheels with the most traction. The centre differential can also be locked providing a 50/50 torque split. In addition, the LC3 model features a rear differential lock.

The Land Cruiser LC3 is offered with an efficient, powerful 3.0 litre D-4D diesel engine and the option of a five-speed electronically controlled automatic transmission (five-door only). What's more, it comes with cruise control, leather steering wheel, dual-zone climate controlled air conditioning, advanced six-speaker CD/tuner unit, power adjustable and heated exterior mirrors – which also retract at the touch of a button for tight parking situations – front fog lamps, retractable headlamp washers and a metallic cover for the centre section of the spare wheel.

On or off the road, the Land Cruiser LC3 is equipped for action.



Electric windows

Power windows have an anti-jamming feature for safe operation.



Fog lamps

Front fog lamps provide improved visibility in murky conditions.



Air conditioning

Dual-zone climate controlled air conditioning keeps the cabin at your preferred temperature.





Innovations deliver superior performance

When it comes to the Sports Utility Vehicle market, Land Cruiser leads the way. Its world-beating off-road performance is matched by its unrivalled power, spaciousness, safety and technology.

The LC4 model typifies its supremacy. It is equipped with a world-first feature – Hill-start Assist Control (HAC). This fully automated system, available on models with automatic transmission, prevents the car from sliding backwards when starting on an uphill slippery slope. It complements the class-leading Downhill Assist Control (DAC), which controls the car on awkward descents, stopping it from ‘running away’.

All LC4 models are fitted with Vehicle Stability Control (VSC) to help control understeer and oversteer, and Active-Traction Control (A-TRC) to prevent wheel-slip (A-TRC replaces the rear differential lock).

For comfort and convenience, the LC4 is equipped with electrically adjustable and heated front seats, leather seat facings, plus an electric tilt/slide sunroof and Optitron instrumentation. To make long road journeys even more pleasurable, it comes with an integrated radio/CD tuner with six-speaker output, Toyota’s advanced, multi-feature turn-by-turn satellite navigation system with Electronic Traffic Avoidance and colour-keyed spare wheel cover. The LC4 is also available with the no cost option of an underfloor-mounted spare wheel (standard on petrol model).

The Land Cruiser LC4 helps keep you out of trouble – wherever you explore.

Sunroof

The electric tilt/slide sunroof features a shade as well as anti-trap and key-off functions.



Optitron instrumentation

Clear and easy to read, the white Optitron instrumentation provides enhanced, at-a-glance visibility.



Load space

Fold back the third row of seats and there’s plenty of load space as well.



Top of the class

For more than half a century, the Toyota Land Cruiser has led the way in 4X4 technology. Now it adds to its outstanding pedigree by offering premium levels of comfort, convenience and quality to deliver a truly exceptional on- and off-roader, designed for 21st century lifestyles.

The Land Cruiser LC5 says it all. It has the power – a choice of the hi-tech 3.0 litre D-4D diesel engine with outstanding torque and the 4.0 litre VVT-i V6 petrol unit for powerful, efficient engine performance. It has the technology – ABS braking with EBD, Brake Assist, Vehicle Stability Control, Active-Traction Control, Downhill Assist Control*, Hill-start Assist Control* and centre differential with diff-lock. It also has TEMS, Toyota Electronically Modulated Suspension, which automatically adjusts shock absorber settings according to driving conditions.

Adding to all this technical excellence, it also has high levels of sophistication and quality. In addition to the impressive LC4 specification, it has dual-zone climate controlled air conditioning with front and rear controls and a superb audio system, including radio, cassette player and six-disc CD autochanger, delivering outstanding sound quality through nine speakers. Drivers also benefit from the convenience of an advanced full-map GPS DVD voice-navigation system with a multi-function, seven-inch colour display screen.

With Toyota's three-year/60,000 mile mechanical and paint warranty, plus a 12-year anti-corrosion guarantee, you can be assured that the Land Cruiser legend will live on.

* Automatic only.



EMV display screen

The seven-inch EMV display screen offers a range of functions, including audio and air conditioning operation and full-map DVD satellite navigation system with Electronic Traffic Avoidance.



Leather upholstery

The comfortable seats feature leather facings, adding an extra luxurious feel.



Rear air conditioning

Rear-seat passengers can adjust air flow.



In the comfort zone



The first things that strike you when you step inside a Land Cruiser are the sense of space and the sheer quality of your surroundings. You immediately feel comfortable and at home. The cabin is wide and long, giving you extra leg and shoulder room. So there's even more space to accommodate up to eight adults in the five-door versions and up to five in the three-door models.

Velour or leather seat facings, air conditioning and advanced noise insulation all ensure that every occupant enjoys a quiet, comfortable ride experience, complemented by Land Cruiser's outstanding suspension and handling qualities.

For comfort, the front seats are multi-adjustable with lumbar support and, on the top two models, heated as well. The rear seats are multi-functional, giving you a wide variety of passenger and cargo configurations. The second row of seats offers a 60/40 split/fold capability while, on the five-door version, the third row has a 50/50 split/fold capability and is removable.

The Land Cruiser – absolute proof that comfort never has to be compromised in a 4WD.

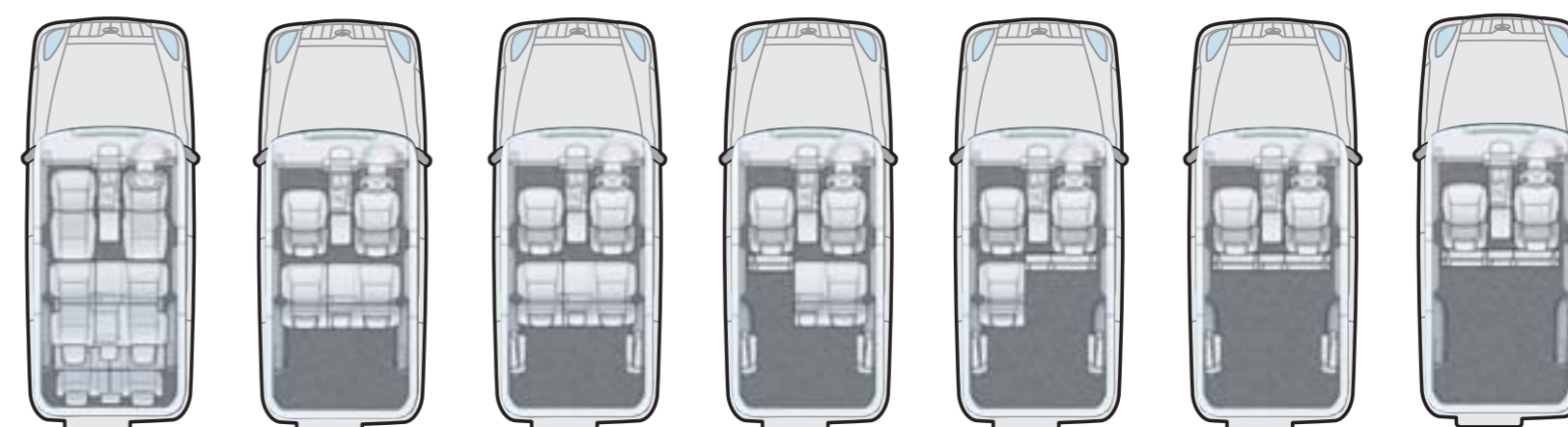

Such flexibility – the five-door Land Cruiser gives you a range of passenger and load options, from a full eight-seater to maximum carrying capability.

A controlled experience



Driving a 4WD is a different experience to everyday motoring. More than ever, you need to be in absolute control – and feel in control. Which is why the Land Cruiser has been designed throughout with the driver in mind, to give you extra reassurance and confidence.

It starts by making you a comfortable driver with the telescopic tilt-adjustable steering column and multi-adjustable, ergonomically-designed driver's seat, and by placing all controls and instruments within easy reach and sight to minimise driver distraction. Optitron instruments on the top two Land Cruiser grades, for example, deliver outstanding clarity.

For supreme comfort, the front seats have an eight-way adjustable facility and lumbar support (powered and heated depending on grade).

Cup holders are handily situated front and rear for maximum convenience and spillage avoidance.





Leading the way in 4WD technology

Sophisticated technology, particularly to aid vehicle control and improve ride comfort and safety, is at the heart of the Land Cruiser's appeal, and underlines its class-leading status.

With its permanent 4WD system, interchangeable 'hi-low' transfer gearbox ratios and 'intelligent' Torsen centre limited slip differential, the Land Cruiser delivers first-class traction on all surfaces. This ability is further enhanced by Active-Traction Control (A-TRC), which directs the most power to the wheels with the most traction (available on LC4 and LC5).

Off-road performance is made even more secure by the world-first Hill-start Assist Control (HAC), which automatically applies the brakes for a few seconds to prevent back-slip on hill-starting, and by Downhill Assist Control (DAC). Using wheel direction sensors, DAC slows the vehicle on downward slopes, stopping it from 'running away' (available on LC4 and LC5).

Ride comfort, handling and stability are all improved on LC5 models by the Toyota Electronically Modulated Suspension (TEMS) which, by automatically adjusting shock absorber settings to suit driving conditions, controls body roll and provides better feedback for the driver.

TEMS is integrated with a rear air suspension system featuring active body height adjustment with automatic levelling that provides a smoother ride whilst maintaining the body at a constant height, irrespective of passenger numbers and cargo load.

The Land Cruiser – technologically advanced for exceptional performance.

Toyota Electronically Modulated Suspension (TEMS)

Toyota's advanced TEMS system delivers a stable, comfortable ride in both on- and off-road situations (LC5).

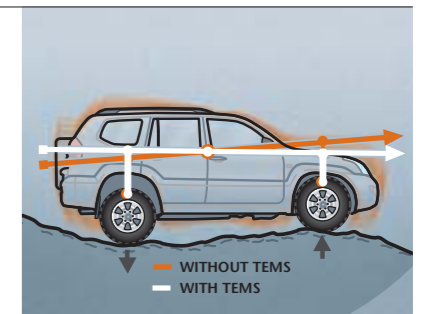

Downhill Assist Control

Driver-operated Downhill Assist Control prevents the vehicle 'running away' on slippery slopes (LC4 & LC5 automatic models).

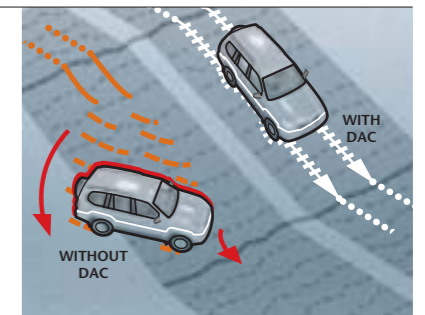

Hill-start Assist Control

A world-first innovation, Hill-start Assist Control means no more back-sliding when starting on slippery inclines (LC4 & LC5 automatic models).

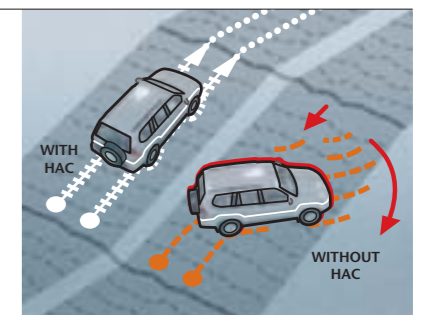

Off-road capabilities

With its class-leading 4WD technology, the Land Cruiser can take you wherever you want to go.

Approach angle

3-door – 32°
5-door – 32°

Wading capability

3-door – 700 mm
5-door – 700 mm

Ramp over angle

3-door – 24°
5-door – 20°

Climbing angle

3-door – 42°
5-door – 42°

Departure angle

3-door – 30°
5-door – 27°

Traversing angle

3-door – 42°
5-door – 42°

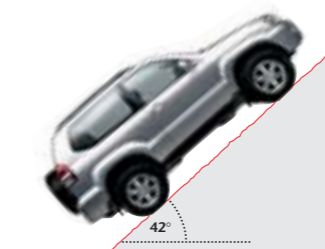
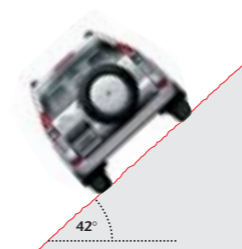
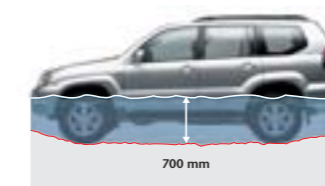

AMAZON



The best just gets better

The Land Cruiser Amazon, one of the most powerful off-roaders on the market, has been designed to offer even more luxury, more technology and more safety to help maintain its position as one of the most prestigious 4X4s available. The exterior conveys a strong road presence, reinforcing the Amazon's tough, dynamic image, while innovative technology and refinements deliver outstanding performance and sophistication.

There is a choice of two powerful engines. The mighty 4.7 litre V8 petrol unit is complemented by a five-speed electronically controlled automatic transmission, while the 4.2 litre turbo-diesel is offered with both manual and automatic transmission. While producing outstanding power, both engines deliver good fuel economy and low emissions. The diesel engine with five-speed electronically controlled automatic transmission, for example, can deliver 0-62 mph acceleration in just 11.5 seconds, yet still return 26.6 mpg on the combined cycle.

The petrol version is the first vehicle in the world to be fitted with Variable Gear Ratio Steering (VGRS), delivering improved handling and stability, as well as greatly enhanced steering feel.

With the Land Cruiser Amazon, refinement doesn't stop with technical innovation. Its impressive specification includes leather seat facings, 18" alloy wheels, climate controlled air conditioning, Electronic Multi-Vision (EMV) system, DVD full-map satellite navigation system with Bluetooth™ telephone interface, rear-view monitor system and eight airbags.

The Land Cruiser Amazon – more of the best.

Full-map satellite navigation
Finding and reaching your destination is made easy with the help of Toyota's full-map satellite navigation system with Electronic Traffic Avoidance (ETA).



Rear-view monitor system
A valuable aid to reversing is the Amazon's innovative rear-view monitor system. Once reverse gear is engaged, a wide-angle TV camera on the back door transmits the rearward view to the multi-display screen in front of the driver.



Rear-seat audio controls
Rear-seat passengers are put in complete control of the high quality sound system with rear-seat audio controls.





Comfortably in control



Supremely comfortable, spacious and quiet, the Land Cruiser Amazon's cabin cocoons you with its aura of luxury – from the leather seat facings to the pure sound quality of the sophisticated seven-speaker audio system with automatic volume control.

The interior has also been designed to put the driver at ease and in complete control. The driver's electrically adjustable and heated seat – with lumbar support – has a dual-setting memory function linked to the exterior mirrors and steering wheel. The ergonomic design is further enhanced by steering wheel-mounted audio controls and the

Optitron instrumentation. Centrepiece of the main console is the Electronic Multi-Vision (EMV) system with its seven-inch, touch-sensitive, colour screen, displaying audio settings and selections, climate controlled air conditioning operation, full-mapping DVD-based navigation system, rear-view monitor system and Bluetooth™ telephone interface operation.

Rear audio controls, rain sensitive windscreen wipers, electric tilt/slide sunroof, plus the premium quality of all interior materials add to the exceptional levels of comfort and convenience that make the Land Cruiser Amazon so desirable. The Land Cruiser Amazon – for those who enjoy their creature comforts as well as the great outdoors.

Cruise control

An aid to more relaxed driving, cruise control is one of the many standard features on the superbly equipped Land Cruiser Amazon.



Seat memory

The electrically adjustable driver's seat has a dual-setting memory function which is linked to the position of the steering wheel and exterior mirrors.



Rear-seat air conditioning

Rear-seat passengers can adjust the climate controlled air conditioning to find their preferred temperature.



Electrochromic rear-view mirror

Cuts glare by automatically dimming the headlight reflection from following cars.



Technology with a purpose

In keeping with its reputation for engineering excellence, the permanent 4WD Land Cruiser Amazon is the first vehicle in the world to be equipped with Variable Gear Ratio Steering (VGRS) (petrol only). This automated system adjusts the steering gear ratios according to the vehicle's speed and the driver's steering effort. The result is improved handling and stability at all speeds, as well as increased safety in the event of sudden braking and veering.

The Land Cruiser Amazon's two engines are not just powerful, they're efficient, too. The 4.7 litre petrol engine features an Electronic Throttle Control System – intelligent (ETCS-i) that delivers a smooth, responsive performance, while the 4.2 litre turbo-diesel unit has an electronically controlled injection pump and intercooler.

Toyota Electronically Modulated Suspension (TEMS), an automated system that adjusts shock absorber settings and vehicle height for improved ride comfort, handling and stability, is fitted to all Land Cruiser Amazons, as is Active Height Control, a self-levelling active height suspension. Centre (and rear on diesel) differential locks to help prevent the wheels spinning in soft-ground conditions are also standard.

Moreover, the petrol-engine Land Cruiser Amazon has the benefit of Traction Control (TRC) for even more effective wheel-spin control. Amazon VVT-i features Vehicle Stability Control (VSC) which counters understeer and oversteer by automatically controlling engine output and braking.

The Land Cruiser Amazon – giving you the power and control to explore.

Toyota Electronically Modulated Suspension (TEMS)

The TEMS system delivers superior handling, stability and ride comfort in on- and off-road situations.



4.7 litre V8 petrol engine

The mighty 4.7 litre V8 petrol engine, featuring an intelligent throttle control system, delivers a powerful but quiet performance.



4.2 litre turbo-diesel engine

The 4.2 litre turbo-diesel engine, with electronically controlled injection pump and intercooler, provides superb all-round performance and fuel efficiency.



Off-road capabilities

The Land Cruiser Amazon's rough terrain abilities are second to none.

Approach angle

34°

Ramp over angle

24°

Departure angle

23°

Wading capability

700mm

Climbing angle

45°

Traversing angle

45°

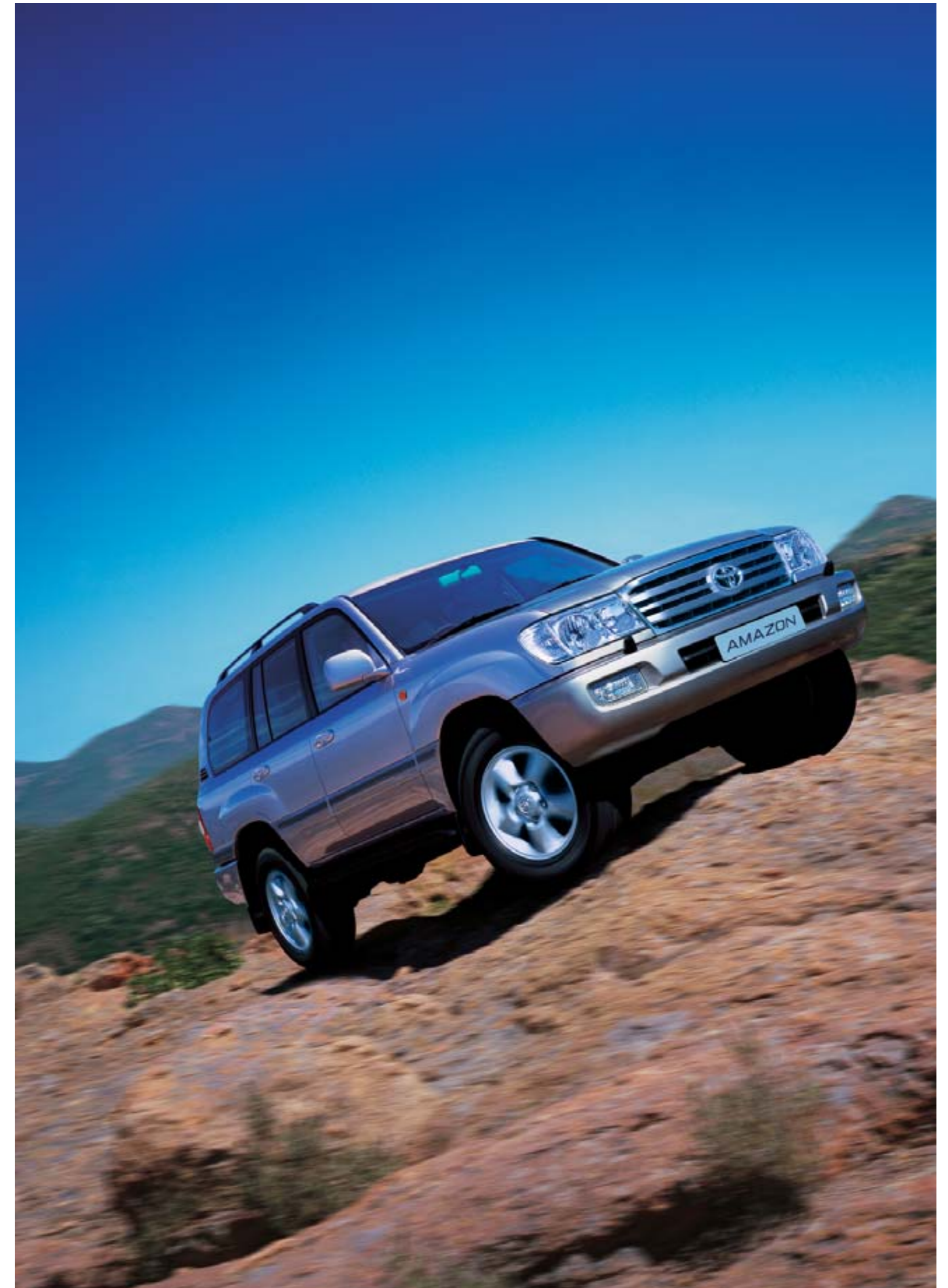

Safety matters

Safety is a prime consideration with all Toyota vehicles. The Land Cruiser and Land Cruiser Amazon are perfect examples.

Through the use of high-strength, tensile steel, the bodies are supremely strong and rigid to absorb impact energy.

Advanced seat belt technology, with pre-tensioners and force-limiters, is complemented by the comprehensive SRS airbag protection system. Two-stage front airbags are supplemented by side airbags and by front and second row curtain shield airbags. The Land Cruiser Amazon also has a rollover-sensing curtain airbag protection feature.

Primary safety features include ABS braking with EBD (Electronic Brake force Distribution) Brake Assist and, depending on model, Vehicle Stability Control, Traction Control, Hill-start Assist Control and Downhill Assist Control – everything, in fact, to make the Toyota 4WD experience safe and more enjoyable.

For even greater peace of mind, every Land Cruiser and Land Cruiser Amazon comes with engine immobiliser, alarm, remote central double locking, window etching, parts marking and locking wheelnuts.

Toyota safety systems – protecting you, your family and your Land Cruiser.



Anti-lock Brake System (ABS) with Electronic Brake force Distribution (EBD)
ABS with EBD gives the Land Cruiser a high level of safe braking performance.

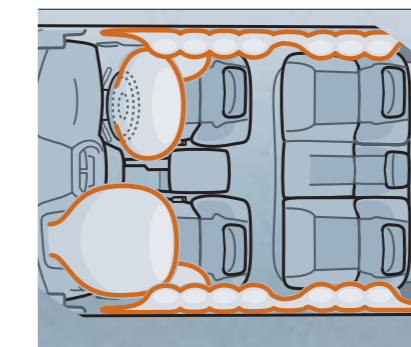

SRS airbags
Together with dual two-stage front airbags, side and curtain airbags afford maximum occupant protection.

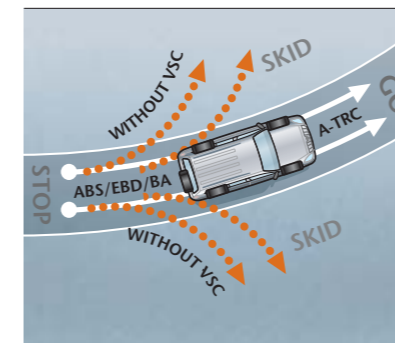

Vehicle Stability Control (VSC) and Active Traction Control (A-TRC)
Sophisticated safety features, including ABS with EBD and BA – plus VSC and TRC on LC4, LC5 and Amazon VVTi – make driving the Land Cruiser all the more reassuring.



Crash resistant bodyshell
The strong, rigid frame incorporates high levels of energy-absorbing material to reduce the effects of frontal, rear and side impacts.





Drive Plans from Toyota Financial Services

We want to make acquiring and maintaining your Land Cruiser as easy as driving one. Our range of Toyota Drive Plans have been designed specifically with this in mind, to offer you a choice of affordable ways to finance, service and maintain your new car. Above all our plans offer flexibility, easy budgeting and peace of mind and can be arranged as a one-stop-shop when you select your Land Cruiser.

Easy Start

With Easy Start finding a large deposit is not an issue. Just the equivalent of one monthly payment in advance is all that is needed to drive away in a Land Cruiser. This simple and innovative plan, based on our popular PCP Drive Plan, is ideal for younger customers or families on a tight budget.

Easy Drive

Easy Drive is a comprehensive finance package, with one monthly payment taking care of most of your motoring needs for 2 or 3 years. The plan includes the cost of a Land Cruiser on a PCP Drive Plan and an Easy Care servicing plan covering routine, major and intermediate services.

Easy Care

For those who value the peace of mind of a pre-paid servicing package we can offer Toyota Easy Care. The plan ensures that your Land Cruiser will receive the very best maintenance and servicing. Easy Care covers routine major services (including routine servicing, parts and labour) and intermediate oil and filter services.

Business Drive

Business Drive offers the security of a fully maintained Contract Hire package, ideally suited for VAT registered businesses. The package offers a host of benefits including reduced capital outlay, all-inclusive monthly rentals and no depreciation, disposal or administration problems.

Flexible Finance

However, Drive Plans are about more than just these four schemes. Whatever your needs, Toyota has a full range of finance options to offer you. Whether you're a private motorist or a business customer, just discuss your individual requirements with your Toyota Centre, who will be pleased to help you choose a Drive Plan to suit you.

Indemnities may be required. All finance subject to status.

Toyota Financial Services (UK) PLC, Great Burgh, Burgh Heath, Epsom, Surrey KT18 5UX

Add individual style

Whether you want to add a stylish individual touch with a set of dynamic alloy wheels, further increase its convenience with advanced features such as satellite navigation or tailor it to fit into your hectic lifestyle, the Land Cruiser is available with a range of quality accessories designed specifically for your car.

Audio

6-disc CD autochanger and fitting kit – except LC₅

Active subwoofer and fitting kit, 120w (81dB) – except LC₅

Body exterior

Bumper corner protectors – compatible with parking corner sensors, black (can be painted)

Front guard – black PU-shell type guard with ABS, light grey under engine cover (can be painted)

Convenience

Cool/hot box – 25 litres cooling/heating volume – can be divided into 14 litres cooling/heating volume and 11 litres storage space, plus optional carry straps

Toyota Parking Aid – 4-sensor system (available in black or colour matched)

European satellite navigation system (TNS300) – LC₃

European satellite navigation system with Electronic Traffic Avoidance (TNS300 and ETA) – LC₃ (factory option)

Europe DVD – required for above systems

Toyota Hands Free (THF) mobile phone kits

Wind deflector – front set, dark transparent

Interior trim

Carpet mats – tailored velour set of 4 (2 front and 2 rear) anthracite or beige

Scuff plates – front pair to protect front door sills

Shift knob – wood/leather, set of 2 – manual only

Lights

Headlamp beam converters – please ask your Toyota Centre for outline details

Load space

Boot liner – tailored, tough plastic, compatible with vertical and horizontal cargo nets, in-room bike holder and cool/hot box

Cargo net, horizontal – keeps large items secure, compatible with boot liner and vertical cargo net, but not 3rd row seats

Cargo net, vertical – keeps small items upright/secure, compatible with boot liner, horizontal cargo net, cool/hot box, 3rd row seats

Dog guard

In-room bicycle holder – compatible with cool/hot box and boot liner, fixes onto vehicle floor using existing seat anchorage points, two can be fitted

Locks

TRACKER stolen vehicle tracking systems: Retrieve, Monitor or Horizon

Roof

Crossbars – anodised aluminium and black end cap, set of 2, max load 60 kg incl. crossbars

The following accessories can only be fitted with the crossbars:

Bicycle holder – quick attachment, holds one bicycle, two holders can be fitted, up to 55 mm wheel diam., max load 15 kg

Bicycle holder – universal, holds one bicycle, two holders can be fitted, up to 55 mm wheel diam., max load 15 kg

Lockable knob – for universal bike holder

Luggage box – 380 litres, outer dimensions 150 cm x 90 cm x 35 cm, 15 kg weight

Luggage platform 100 cm x 110 cm – one can be fitted

Sailboard and mast holder – one can be fitted

Ski holder – horizontal, one can be fitted, holds 1 snowboard and 4 pairs downhill or 5 pairs cross-country skis

Ski holder – vertical, one can be fitted, holds 1 snowboard and 3 pairs downhill or 5 pairs cross-country skis

Safety

Child seat – class G0+, approx. up to 15 months (up to 13 kg)

Child seat – with ISOFIX fixation, class G1, approx. 8 months–4 yrs (9–18 kg)

Child seat – class G2/3, approx. 3–12 yrs (15–36kg)

Towing

Flanged tow bar – (two ball positions possible, non-detachable) max towing capacity 2800 kg, nose weight 130 kg

Fixed tow bar – max towing capacity 2800 kg, nose weight 130 kg

12N Multiblock tow bar wiring

12S Caravan services

Rear bicycle holder and rear lamp set – holds 2 bikes (must be fitted with tow bar) not compatible with parking aid unless a cancellation switch is purchased, 3rd bike extension set can be fitted

Ventilation

Clean air replacement filter – it is recommended that the filter is replaced annually to maintain clean air filter performance

Wheels

Spare wheel cover – lockable, ABS, light or dark grey with Land Cruiser logo, fits with rear bicycle holder

Spare wheel cover – (stainless steel rim/dark grey ABS cover, Land Cruiser logo 265/65 tyres) not suitable for Michelin tyres, fits with rear bicycle holder

The above accessories are applicable to all Land Cruiser models unless otherwise stated.



Make a personal statement

The Land Cruiser Amazon is the ultimate go-anywhere vehicle. The comprehensive range of bespoke accessories available allow you to customise its looks, practicality and performance to perfectly complement your lifestyle whilst ensuring Toyota's trademark quality and style.

Audio

Sony replacement rear headphone set

Body exterior

Front guard – wrap around (PU RIM SS-plate on centre bar with Land Cruiser logo, black, can be painted)

Stainless steel exhaust trim – not compatible with tow bar

Fender protectors – black, set 4, can be painted, to protect wheel arches

Convenience

Cool/hot box – 25 litres cooling/heating volume – can be divided into 14 litres cooling/heating volume and 11 litres storage space

Toyota Parking Aid – 4-sensor system (available in black or colour matched)

Toyota Hands Free (THF) – mobile phone kits

Wind deflector – front and rear set, dark transparent

Interior trim

Carpet mats – front, second and third row, anthracite or beige, tailored velour

Lights

Headlamp beam converters – please ask your Toyota Centre for outline details

Load space

Boot liner – tailored, tough plastic, compatible with vertical & horizontal cargo nets and in-room bike holder

Cargo net, horizontal – keeps large items secure

Cargo net, vertical – keeps small items upright/secure

Dog guard

In-room bicycle holder – compatible with cool/hot box and boot liner fixes onto vehicle floor using existing seat anchorage points, one can be fitted

Locks

TRACKER stolen vehicle tracking systems:

Retrieve, Monitor or Horizon

Roof

Crossbars – set of 2, max. load 100 kg including bars

The following accessories can only be fitted with the crossbars:

Bicycle holder – quick attachment, holds one bicycle, two can be fitted, up to 55 mm wheel diam., max load 15 kg

Bicycle holder – universal, holds one bicycle, two can be fitted, up to 55 mm wheel diam., max load 15 kg

Lockable knob – for universal bike holder

Luggage box – capacity 380 litres, outer dimensions 150 cm x 90 cm x 35 cm, 15 kg weight

Luggage platform 100 cm x 110 cm – one can be fitted

Sailboard and mast holder – one can be fitted

Ski holder – horizontal, one can be fitted, holds 1 snowboard and 4 pairs downhill or 5 pairs cross-country skis

Ski holder – vertical, one can be fitted, holds 1 snowboard and 3 pairs downhill or 5 pairs cross-country skis

Safety

Child seat – class G0+, approx. up to 15 months (up to 13 kg)

Child seat – with ISOFIX fixation, class G1, approx. 8 months–4 yrs (9–18 kg)

Child seat – class G2/3, approx. 3–12 yrs (15–36 kg)

Towing

Tow bar – (3 position detachable ball) max towing weight 3500 kg, nose weight 140 kg, max gross weight 2960 kg

Ball and hitch*

Tow ball*

12N Multiblock tow bar wiring

12S Caravan services – (please state age of caravan)

* Tow ball or ball and hitch required with tow bar.

Wheels

Locking wheel nuts – replacement for original wheels

Above accessories applicable to all Land Cruiser Amazon models.





Technology made simple

Toyota's worldwide reputation for reliability and durability has been built on the back of its technical expertise and innovation. Here is a straightforward guide to the advanced technology that makes the Land Cruiser and Land Cruiser Amazon such outstanding performers, on and off the road.

For a full technical explanation, please consult your local Toyota Centre.

Active Traction Control (A-TRC)

Developed for both on- and off-road use, A-TRC is designed to reduce wheel-spin in slippery conditions by using computer technology to control engine output and brake fluid pressure. After detecting wheel-spin, it distributes the drive force, lost through the slippage, to the wheels having traction. In other words, it automatically delivers more power to the wheels with more traction, giving you greater control.

Air suspension

Air suspension replaces conventional suspension springs with rubber bellows filled with compressed air. This provides superior ride comfort, as well as the ability to change the car's body height by controlling the amount of air inside the bellows. In the Land Cruiser LC5, there is an automatic levelling feature, which maintains the body at a constant height, irrespective of the number of passengers and cargo. At the touch of a button, air suspension can raise or lower the ride height by 30 mm (60 mm in total).

Anti-lock Braking System (ABS)

ABS uses a hydraulic control unit with four active electronic sensors to prevent the wheels from 'locking' during braking, especially sudden braking. By helping to maintain vehicle stability and enhance steering performance, it is a key safety feature. The ABS system is the heart of all electronic handling features.

Bluetooth™ telephone interface

Bluetooth's™ advanced wireless technology gives you complete hands-free control of your Bluetooth™-compatible mobile phone, enabling you

to make calls, scroll through the phone book and carry out other functions of the phone. A Bluetooth™ unit, consisting of an antenna and a module, is integrated into the multi-display, and when activated via a steering wheel control, 'takes over' all the services of your phone – without any wired connections. A microphone is installed in the overhead console and a speaker is mounted in the driver's door.

Body-on-frame construction

All Land Cruisers are built using body-on-frame technology to produce a more rigid and robust chassis, capable of withstanding the use and abuse of the severest of off-road conditions. Unlike monocoque chassis construction, body-on-frame can withstand higher stress without suffering permanent deformation, which would compromise the vehicle's handling.

Brake Assist

Brake Assist senses when the driver is attempting an emergency stop by monitoring driver brake effort. It then applies additional brake fluid pressure for maximum braking performance, maintaining the extra pressure until the system detects intentional relaxation of the brake pedal.

Downhill Assist Control (DAC)

Driver-operated, DAC slows the vehicle on slippery downhill slopes to help regain control and prevent vehicle 'run-away'. An improvement on existing systems, it uses individual wheel-direction sensors to maintain slower, controlled speeds, whether going forwards or backwards. It can even be activated when the gear is in neutral.

Differential locks – centre and rear

For difficult off-road conditions, the centre differential can be locked to provide a permanent torque distribution of 50% to the front wheels and 50% to the rear ones, thereby delivering more even traction. The rear differential with electric lock, ensures power is distributed to both rear wheels, for heavy off-road usage.

Electronic Brake-force Distribution (EBD)

Using the ABS control unit and sensors, EBD automatically applies the correct braking force to each wheel to compensate for different loads when cornering or heavy straight-line braking.

Electronic Multi-Vision (EMV)

EMV is the driver's 'window' and control for a variety of in-car functions. On its touch-sensitive, seven-inch colour screen are displayed audio settings and selections, air conditioning status with temperature control function, screen brightness adjustment, and full-mapping DVD-based satellite navigation system.

Hill-start Assist Control (HAC)

A world-first, HAC is a fully automated control that prevents the vehicle from slipping backwards when starting on a slippery uphill slope. Without it, the driver must quickly switch from the brake to the accelerator, allowing time for backward slippage. To prevent this happening, HAC temporarily applies all four brakes, ensuring a more assured start.

Optitron instrumentation

Optitron replaces traditional instrument panel illumination with individual LEDs (Light Emitting Diodes) on every figure and indicator needle. Located behind a low-reflection, smoked acrylic face, they provide outstandingly clear readability, whatever the light conditions. They also add a more refined appearance to the instrument panel.

Rear-view monitor system

As soon as the driver selects reverse gear, a back-door-mounted colour TV camera, using a charge coupled device and wide-angle lens,

transmits the rear view, via a special camera control, to the multi-display screen on the centre console. The system is an aid to reversing and parking – never depend on it entirely when backing up and never reverse while looking only at the screen.

Toyota Electronically Modulated Suspension (TEMS)

This semi-active suspension system automatically adjust shock absorber settings to suit driving conditions. It continually monitors a variety of vehicle operation signals, which after processing are sent to actuators at each of the four shock absorbers. These then constantly control the damping forces of the shock absorbers through 11 different control commands.

Torsen LSD centre differential with diff-lock

This uniquely designed limited slip differential (LSD) ensures an 'intelligent' torque split between front and rear wheels, always favouring the wheels with most traction. If, for example, the front wheels are spinning faster than the rear ones, more power will be automatically transferred to the rear ones until a maximum is reached. For more difficult off-road conditions, the differential can be locked, providing a permanent torque distribution to front/rear wheels.

Variable Gear Ratio Steering (VGRS)

The Land Cruiser Amazon petrol version is the first vehicle in the world to be fitted with VGRS which, by adjusting the steering gear ratios according to vehicle speed, improves handling and stability. An actuator, located on the steering intermediate shaft, controls the steering angle to match the driver's steering input and the vehicle's speed. This results in improved steering response and vehicle stability, even in sudden manoeuvres.

Vehicle Stability Control (VSC)

VSC minimises the effects of oversteer and understeer by automatically sensing when the vehicle starts to lose tyre grip due to a sudden steering movement or change in the road surface. It then applies the brakes to individual wheels and reduces engine output to compensate.

Colours and trims

Metallic paint is available as a cost option on Land Cruiser and Land Cruiser Amazon.
Models shown below are Land Cruiser LC3.

056 Arctic White Yosemite velour (LC3) • Yukon leather (LC4 & LC5)
 Katmai Grey full leather (option on LC3)



202 Astral Black Yosemite velour (LC3) • Yukon leather (LC4 & LC5)
 Katmai Grey full leather (option on LC3)



3Q8 Ember Red* Redwood velour (LC3) • Sequoia leather (LC4 & LC5)
 Denali Beige full leather (option on LC3)



6Q7 Ashdown Green* Redwood velour (LC3) • Sequoia leather (LC4 & LC5)
 Denali Beige full leather (option on LC3)



8S6 Dark Blue* Yosemite velour (LC3) • Yukon leather (LC4 & LC5)
 Katmai Grey full leather (option on LC3)



4R4 Cornsilk* Yosemite velour (LC3) • Yukon leather (LC4 & LC5)
 Katmai Grey full leather (option on LC3)



1E9 Graphite Grey* Yosemite velour (LC3) • Yukon leather (LC4 & LC5)
 Katmai Grey full leather (option on LC3)



1D4 Argenta* Yosemite velour (LC3) • Yukon leather (LC4 & LC5)
 Katmai Grey full leather (option on LC3)



Yosemite velour



Redwood velour



Katmai Grey full leather
 (option on LC3)

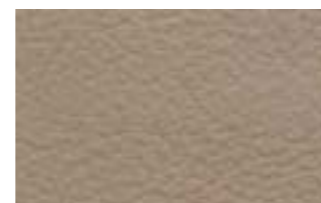

Denali Beige full leather
 (option on LC3)

056 Arctic White Granite leather



202 Astral Black Granite leather



1F7 Tyrol Silver* Granite leather



3Q2 Rioja Red* Sand Storm leather



6R4 Island Green* Sand Storm leather



8R3 Slate Blue* Granite leather



1E9 Graphite Grey* Granite leather



Sand Storm leather



Granite leather

* Metallic paint.

* Metallic paint.

Specifications

Land Cruiser – three-door

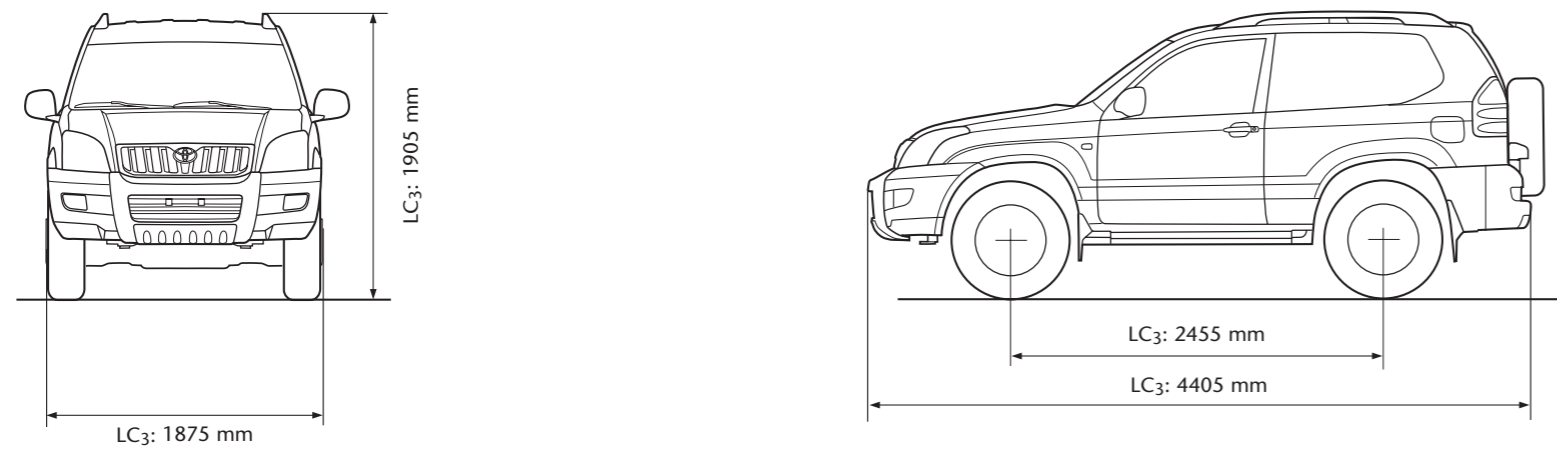

Land Cruiser – five-door

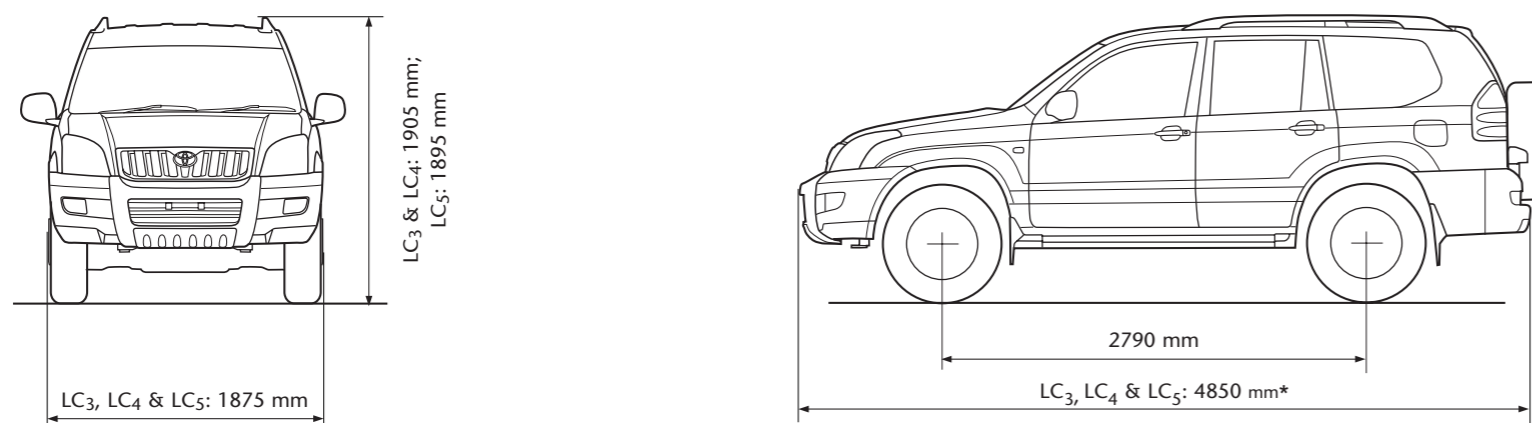

* LC4 & LC5 with underbody spare wheel: 4715 mm.

Land Cruiser Amazon – five-door

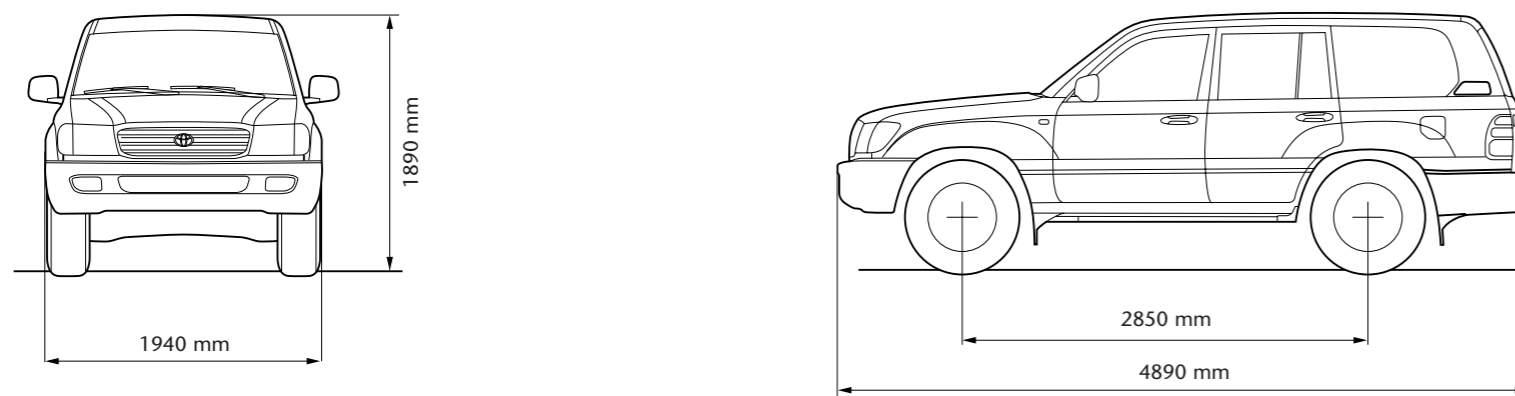

All Land Cruiser and Land Cruiser Amazon measurements include roof rails but not wing mirrors.

DIMENSIONS

	Land Cruiser 3-door	Land Cruiser 5-door	Amazon 5-door
Interior dimensions			
Length (mm)	1805	2520	2505
Width (mm)	1535	1535	1620
Height (mm)	1260	1260 (LC4 & LC5: 1220)	1150
Cargo area length (mm)	1145	1585	1725
Cargo area width (mm)	1430	1460	1594
Cargo area height (mm)	1095	1120	1069
Exterior dimensions			
Minimum ground clearance (mm)	222	222	256
Turning radius (m)	5.2	5.7	5.9
Wheel size	265/65 R17	265/65 R17	275/60 R18

TRANSMISSION

		3.0 litre D-4D 6 M/T	3.0 litre D-4D 5 A/T	4.0 litre VVT-i V6 5 A/T	4.2 litre TD 5 M/T	4.2 litre TD 5 A/T	4.7i litre V8 5 A/T
3-door	LC ₃	•	–	–	–	–	–
5-door	LC ₃	•	•	–	–	–	–
	LC ₄	•	•	•	–	–	–
	LC ₅	•	•	•	–	–	–
	Amazon	–	–	–	•	•	•

ENVIRONMENTAL PERFORMANCE

Fuel consumption		3.0 litre D-4D 6 M/T	3.0 litre D-4D 5 A/T	4.0 litre VVT-i V6 5 A/T	4.2 litre TD 5 M/T	4.2 litre TD 5 A/T	4.7i litre V8 5 A/T
Combined mpg (litres/100 km)	3-door Land Cruiser	31.4 (9.0)	–	–	–	–	–
	5-door Land Cruiser	31.0 (9.1)	31.4 (9.0)	22.2 (12.7)	–	–	–
	5-door Amazon	–	–	–	25.4 (11.1)	26.6 (10.6)	17.3 (16.3)
Extra urban mpg (litres/100 km)	3-door Land Cruiser	35.8 (7.9)	–	–	–	–	–
	5-door Land Cruiser	35.8 (7.9)	37.7 (7.5)	27.7 (10.2)	–	–	–
	5-door Amazon	–	–	–	30.4 (9.3)	31.4 (9.0)	21.1 (13.4)
Urban mpg (litres/100 km)	3-door Land Cruiser	25.7 (11.0)	–	–	–	–	–
	5-door Land Cruiser	25.4 (11.1)	24.4 (11.6)	16.0 (17.7)	–	–	–
	5-door Amazon	–	–	–	20.0 (14.1)	21.1 (13.4)	13.1 (21.5)
Recommended fuel grade		diesel	diesel	unleaded	diesel	diesel	unleaded
Fuel tank capacity (litres)		87	87	87	96	96	96
Carbon dioxide CO ₂ (g/km)	3-door Land Cruiser	242	–	–	–	–	–
	5-door Land Cruiser	244	243	305	–	–	–
	5-door Amazon	–	–	–	292	282	387

PERFORMANCE

	3.0 litre D-4D 6 M/T	3.0 litre D-4D 5 A/T	4.0 litre VVT-i V6 5 A/T	4.2 litre TD 5 M/T	4.2 litre TD 5 A/T	4.7i litre V8 5 A/T
Maximum speed* mph	109	109	109	106	112	112
Acceleration 0–62 mph (sec)	11.5	11.2	9.1	13.6	11.5	11.2

WEIGHTS

Fuel consumption		3.0 litre D-4D 6 M/T	3.0 litre D-4D 5 A/T	4.0 litre VVT-i V6 5 A/T	4.2 litre TD 5 M/T	4.2 litre TD 5 A/T	4.7i litre V8 5 A/T
Kerb weight (kg) (min–max)	3-door Land Cruiser	1850–2020	–	–	–	–	–
	5-door Land Cruiser	1990–2180	2000–2190	1910–2080	–	–	–
	5-door Amazon	–	–	–	2495–2640	2510–2660	2320–2525
Gross vehicle weight (kg) (max)	3-door Land Cruiser	2600	–	–	–	–	–
	5-door Land Cruiser	2850	2850	2850	–	–	–
	5-door Amazon	–	–	–	3260	3260	3260
Axle capacity (kg) (front-rear)		1290–1800	1290–1800	1290–1800	1630–1950	1630–1950	1630–1950
Towing capacity with brakes (kg)		2800	2800	2800	3500	3500	3500

PHYSICAL CAPABILITIES

	Land Cruiser 3-door	Land Cruiser 5-door	Amazon 5-door
Angle of approach (degrees)	32	32	34
Angle of departure (degrees)	30	27	23
Ramp over angle (degrees)	24	20	24

M/T = Manual transmission

A/T = Automatic transmission

• = Standard

– = Not available

* Manufacturer's figures.

ENGINE

	3.0 litre D-4D	4.0 litre VVT-i V6	4.2 litre TD	4.7i litre V8
Engine code	1KD-FTV	1GR-FE	1HD-FTE	2UZ-FE
Number of cylinders	4 in line	6 V-type	6 in line	8 V-type
Valve mechanism	DOHC	DOHC	OHC	DOHC
Fuel injection system	Direct injection with common rail	Electronic fuel injection	Direct injection	Electronic fuel injection
Displacement (cc)	2982	3956	4164	4664
Bore x stroke (mm)	96 x 103	94 x 95	94 x 100	94 x 84
Compression ratio	17.9:1	10.0:1	18.5:1	9.6:1
Maximum output (kW/rpm)	122 (164 bhp)/ 3400	183 (245 bhp)/ 5200	150 (201 bhp)/ 3400	175 (235 bhp)/ 4800
Maximum torque (Nm/rpm)	410/1800–2600	382/3200	430/1400–3200	434/3400

SUSPENSION

	Land Cruiser	Amazon
Front	Double wishbone, coil spring (LC ₅ includes TEMS)	Double wishbone, torsion bar with AHC & TEMS
Rear	4-link w. coil spring (LC ₅ w. air spring & TEMS)	4-link w. coil spring with AHC & TEMS

BRAKES

Front	Ventilated disc
Rear	Ventilated disc

Equipment

AUDIO

Grade	LC ₃	LC ₄	LC ₅	Amazon
Audio, integrated unique fit with Liquid Crystal Display	•	•	•	•
AM/FM radio with preset settings	•	•	•	•
RDS with PTY & EON settings	•	•	•	•
Cassette player	–	–	•	•
CD player, single disc	•	•	–	–
CD autochanger, glovebox mounted	–	–	•	–
CD autochanger, centre console mounted	–	–	–	•
Speakers – 6	•	•	–	–
Speakers – 7	–	–	–	•
Speakers – 9	–	–	•	–
Audio controls, steering wheel mounted	–	–	–	•
Radio aerial, glass integrated	•	•	•	–
Radio aerial, wing mounted, electric	–	–	–	•
Rear seat, independent audio controls	–	–	–	•

BODY EXTERIOR

Grade	LC ₃	LC ₄	LC ₅	Amazon
Side protection moulding, painted	–	–	–	•
Door handles & mirrors, colour-keyed	•	•	•	•
Front grille, chrome effect	•	•	•	–
Front grille, dark grey metallic with chrome surround	–	–	–	•
Mud flaps	•	•	•	•
Metallic paint	•	•	•	•
Side steps	•	•	•	•

BRAKES

Grade	LC ₃	LC ₄	LC ₅	Amazon
ABS – electronically controlled with Electronic Brake force Distribution	•	•	•	•
Front disc brakes – ventilated	•	•	•	•
Rear disc brakes – ventilated	•	•	•	•
Brake Assist System	•	•	•	•

BUMPERS

Grade	LC ₃	LC ₄	LC ₅	Amazon
Front & rear bumper & wheel arch extensions, colour-keyed	•	•	•	–
Front & rear bumper, painted	–	–	–	•*

CONVENIENCE

Grade	LC ₃	LC ₄	LC ₅	Amazon
Toyota in-car entertainment	•	•	•	•
Turn-by-turn satellite navigation system with European DVD & ETA	•	•	–	–
Full colour map satellite navigation system with European DVD	–	–	•	•§
Bluetooth™ telephone interface	–	–	–	•
Electronic Traffic Avoidance (ETA)	•	•	•	•
Rear-view monitor system	–	–	–	•
Cruise control	•	•	•	•
Driver's footrest	•	•	•	•
Courtesy light, remote operation with delay	•	•	•	•
Fuel cap, remote release	•	•	•	•
Accessory power socket, front & rear	•	•	•	•
Ashtray & cigar lighter	•	•	•	•
Vanity mirrors, driver and front passenger, with cover & illumination	•	•	•	•
Steering wheel, electronic adjustment with memory	–	–	–	•
Variable Gear Ratio Steering (VGRS)	–	–	–	• (petrol only)

INSTRUMENTS

Grade	LC ₃	LC ₄	LC ₅	Amazon
Automatic transmission mode indicator (option linked to automatic transmission)	•	•	•	•
Trip computer, with fuel consumption & average speed display	–	–	–	•
Tachometer	•	•	•	•
Fuel indicator with low fuel warning	•	•	•	•
Water temperature indicator	•	•	•	•
Engine temperature warning	•	•	•	•
Engine management warning	•	•	•	•
Lights on warning	•	•	•	•
Door ajar warning	•	•	•	•
Key in warning	•	•	•	•
Passenger seat belt warning indicator	•	•	•	•
Outside temperature display	•	•	•	•
Instrument display dimmer	•	•	•	•
Digital odometer with two trip meters	•	•	•	•
Digital clock	•	•	•	•
Differential & transfer indicator	•	•	•	•
Optitron instruments	–	•	•	•

• = Standard • = Optional – = Not available

* Dark or light grey depending on exterior colour (see page 35).

§ With voice command.

INTERIOR TRIM

Grade	LC ₃	LC ₄	LC ₅	Amazon
Gear shift knob – leather trimmed	–	•	•	–
Gear shift – leather with chrome details	–	–	–	•
Fascia, brushed aluminium effect with wood effect inserts	•	•	•	–
Door switch – aluminium effect	•	•	•	–
Fascia – wood effect	–	–	–	•
Door switch – wood effect	–	–	–	•
Wood effect on centre console	–	–	–	•

LIGHTS

Grade	LC ₃	LC ₄	LC ₅	Amazon
Fog lamps – front & rear	•	•	•	•
Halogen headlamps with levelling	•	•	•	•
High mounted stop lamp	•	•	•	•
Interior light – front, centre & rear	•	•	•	•
Headlamp washers	•	•	•	•

LOCKS

Grade	LC ₃	LC ₄	LC ₅	Amazon
Central double locking with remote activation	•	•	•	•
Transponder key engine immobiliser	•	•	•	•
Remote alarm with perimeter & microwave interior protection	•	•	•	•
Security window etching linked to 24hr ISR helpline	•	•	•	•
Steering column lock	•	•	•	•
Vehicle parts marking – major parts traceable to VIN	•	•	•	•

LOAD SPACE

Grade	LC ₃	LC ₄	LC ₅	Amazon
Fully trimmed boot	•	•	•	•
Rear tonneau cover	• (3-dr) / * (5-dr)	*	*	*
Luggage area illumination	•	•	•	•

ROOF

Grade	LC ₃	LC ₄	LC ₅	Amazon
Sunroof – electric tilt/slide with shade, one touch anti-trap & key-off function	–	•	•	•
Roof rails	•	•	•	•

STORAGE

Grade	LC ₃	LC ₄	LC ₅	Amazon
Glovebox – illuminated & lockable	•	•	•	•
Front seatback pocket – driver & passenger side	•	•	•	•
Storage box – central tunnel & doors	•	•	•	•
Cup holder – front & rear	•	•	•	•

SAFETY

Grade	LC ₃	LC ₄	LC ₅	Amazon
Airbags – SRS two-stage driver & front passenger	•	•	•	•
Airbags – SRS roof mounted front & rear	•	•	•	•
Airbags – SRS driver & front passenger, lateral	•	•	•	•
3-point seat belts – all seats with Emergency Locking Retractor	•	•	•	•
3-point seat belts – 2nd & 3rd row seats with ELR & ALR	•	•	•	•
Seat belts – front with, pre-tensioner & force-limiter	•	•	•	•
Seat belts – front, height adjustable	•	•	•	•
Child seat fixings – ISOFIX	•	•	•	•§

SAFETY

Grade	LC ₃	LC ₄	LC ₅	Amazon
Seat integrated front seat belt anchorage & support	•	•	•	•
Side impact beams on all side doors	•	•	•	•
Energy absorbing crumple zones front & rear	•	•	•	•
Childproof locks on rear doors	• (5-dr only)	•	•	•

SEATS

Grade	LC ₃	LC ₄	LC ₅	Amazon
Lumbar support – driver	•	•	•	•
Multi adjustable front seats – manual	•	–	–	–
Multi adjustable front seats – electric	–	•	•	• (with memory)
Heated driver & front passenger seat	–	•	•	•
Driver's seat position memory function incl. exterior mirrors & steering wheel	–	–	–	•
50/50 split/fold 3rd row seats (detachable)	• (5-dr only)	•	•	•
60/40 split/fold 2nd row seats	•	•	•	•
8-seat capacity	• (5-dr only)	•	•	–
7-seat capacity	–	–	–	•
5-seat capacity	• (3-dr only)	–	–	–
Recline function on 2nd row seats (7- & 8-seat model)	• (5-dr only)	•	•	•
Armrests – front & rear	•	•	•	•
Seat trim – velour	•	–	–	–
Seat trim – leather seat facings	–	•	•	•
Seat trim – full leather upholstery	•	–	–	–

STEERING

Grade	LC ₃	LC ₄	LC ₅	Amazon
Power assisted steering – electrically controlled	•	•	•	•
Variable gear ratio steering	–	–	–	• (petrol only)
Adjustable steering column – tilt & telescopic	•	•	•	•
Energy absorbing, deformable & retracting steering column	•	•	•	•
Steering wheel with leather trim	•	•	•	•

SUSPENSION

Grade	LC ₃	LC ₄	LC ₅	Amazon
TEMS (Toyota Electronically Modulated Suspension) – semi active suspension	–	–	•	•
Active Height Control system	–	–	–	•
Double wishbone – front	•	•	•	•
4-Link lateral with rod – rear	•	•	•	•

TRANSMISSION

Grade	LC ₃	LC ₄	LC ₅	Amazon
Vehicle Stability Control	–	•	•	• (petrol only)
Traction Control	–	•	•	• (petrol only)
Limited slip differential	•	•	•	•
Differential locks – centre	•	•	•	•
Differential locks – rear	•	–	–	• (diesel only)
4WD	•	•	•	•
6-speed manual	•	•	•	• (5-speed)
5-speed automatic	•	•	•	•
Downhill Assist Control (DAC)	–	• (auto only)	• (auto only)	–
Hill-start Assist Control (HAC)	–	• (auto only)	• (auto only)	–

• = Standard

• = Optional

– = Not available

* Centre option.

§ With top tether.

VENTILATION

Grade	LC ₃	LC ₄	LC ₅	Amazon
Air conditioning system – dual-zone climate control (driver & passenger controls)	•	•	–	–
Air conditioning system – dual zone climate control with front & rear controls	–	–	•	–
Air conditioning system – climate control with front & rear controls	–	–	–	•
Air re-circulation function – electronic	•	•	•	•
Clean air filter	•	•	•	•

VISIBILITY

Grade	LC ₃	LC ₄	LC ₅	Amazon
Front wipers – twin speed & variable intermittent with mist function	•	•	•	–
Front wipers – twin variable intermittent with rain sensors	–	–	–	•
Front & rear windows – electric with ‘one-touch’ & anti-trap mechanism	• (5-dr only)	•	•	•
Sun visors – driver & front passenger	•	•	•	•
Rear screen – heated	•	•	•	•
Rear wipers – intermittent & continual sweep	•	•	•	•
Exterior mirrors – black, electrically adjustable	–	–	–	–
Exterior mirrors – colour-coded, electrically adjustable, heated & retractable	•	•	•	• (with memory)
Rear-view mirror – light sensing & anti glare electrochromic	–	–	–	•
Glass – green tinted	•	•	•	•

WARRANTY

Grade	LC ₃	LC ₄	LC ₅	Amazon
Three-year/60,000 mile mechanical warranty	•	•	•	•
Three-year unlimited mileage paint warranty	•	•	•	•
Twelve-year unlimited mileage anti corrosion perforation warranty	•	•	•	•

WHEELS

Grade	LC ₃	LC ₄	LC ₅	Amazon
17" 6-spoke alloy wheels with locking wheelnuts on 265/65R17 tyres	•	•	•	–
18" 5-spoke alloy wheels with locking wheelnuts on 275/60R18 tyres	–	–	–	•
Full size spare wheel	•	•	•	•
Spare wheel tailgate mounted (N/A on LC ₄ & LC ₅ petrol models)	•	•	•	–
Spare wheel underbody mounted (Standard on LC ₄ & LC ₅ petrol models)	–	◦	◦	•
Hard spare wheel cover, colour-keyed	–	•	•	–
Metallic centre section spare wheel	•	–	–	–

• = Standard ◦ = Optional – = Not available

Peace of mind

Toyota's global reputation for quality and integrity means the Land Cruiser can add peace of mind to its own highly individual range of attributes.

On the day you purchase your Land Cruiser, your Toyota Centre will present you with the ‘Land Cruiser Passport’; a guide to living with your Land Cruiser and making the most of its considerable range of features. Your Toyota Centre will explain the car to you, and always be there, should you require any assistance.

Health and Safety

Your Toyota Centre will also talk you through Land Cruiser's very own ‘Health and Safety’ programme. It's very simple. Your Land Cruiser will only need a full ‘Health and Safety’

check once every two years, or 20,000 miles if you enjoy driving it as much as we think you will. An intermediate oil change with additional ‘Health and Safety’ checks are also required every year or 10,000 miles.

Warranty

We're so confident each and every Land Cruiser is so well built that it comes with a three-year or 60,000 miles warranty against any mechanical failure*. In addition, the paintwork, no matter what colour you select, is guaranteed against defects and surface rust* for three years too. Finally, the body is guaranteed for 12 years against corrosion perforation*.

* Occurring as the result of a manufacturing default.

Customer Services

Club Toyota

When you buy a Toyota you automatically become a member of Club Toyota, for 12 months free of charge. This entitles you to take advantage of a host of benefits including free RAC Roadside Assistance in the UK and Europe, 5% discount on Toyota Insurance for your car and specially negotiated rates for travel insurance, plus exclusive offers and promotions through our quarterly customer magazine.

Toyota Drive Plans

Toyota Drive Plans make acquiring and maintaining your new car as easy as driving it. They offer a choice of affordable ways to help you buy, finance, service and maintain your Toyota.

The range of plans has been structured to offer you flexibility, easy budgeting and peace of mind.

- Easy Start is an exciting new low deposit plan.
- Easy Care offers the complete reassurance of prepaid servicing.
- Easy Drive is a comprehensive plan which takes care of most of your motoring needs for 2 to 3 years with one monthly payment.
- Business Drive is a fully maintained contract hire package most suited to small business customers.

Whatever your personal preference, your Toyota Centre can tailor a Drive Plan to suit your needs perfectly – driving a new car has never been so easy.

Written quotations available on request. All agreements subject to status. Indemnities may be required.

Toyota Insurance

Toyota Insurance is available for Toyota owners at competitive premiums.

To obtain details of the benefits included and to arrange a quotation, please contact your local Toyota Centre or call 0800 350 500.

Toyota Fleet

Toyota Fleet provides complete business solutions for companies that run a fleet of vehicles. For more information on how Toyota Fleet can deliver your fleet requirements either contact your local Toyota Centre or the Toyota Fleet Business Centre on 0845 271 2712.

Toyota Warranties

Every new Toyota comes with a 3-year/60,000 mile manufacturer's warranty, covering your car against the unlikely event of a manufacturing defect causing a mechanical fault, surface rust or paintwork defect. After the initial warranty period has ended you can choose to extend your warranty until the vehicle is seven years old – choosing from a range of packages to suit your vehicle and your needs. All of our warranties cover the main component parts of the vehicle* meaning that you pay for nothing beyond routine servicing and maintenance, so there are no unexpected bills to pay.

* With the exception of batteries, corrosion of exhaust and damage or wear to the interior.

Toyota Accident Assistance

Toyota provides a comprehensive accident management service to all Toyota drivers, giving advice, assistance and practical help free of charge in the event of an emergency.

Toyota Approved Used Car Scheme

All Toyota Approved Used vehicles come complete with a RAC pre-check delivery, a mileage check, a free 600-mile or one-month inspection, 12 months Club Toyota membership and a 14-day no-quibble exchange plan.



The pulp used in this paper is chlorine free and comes from sustainable sources. Please refer to www.toyota.co.uk for further environmental information.



help

Using the navigation bar

A navigation bar is provided at the bottom of each page of this e-brochure to make browsing it easy. Please follow the simple instructions on the right to navigate through this e-brochure.

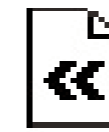

Takes the document back to the beginning.

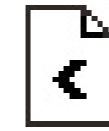

This will take the document back to the previous page.



This will take the document back to the next page.



Takes the document to the Index page.



This will allow the Acrobat toolbar to be visible if pressed once and it will also make it disappear if already visible.



This will zoom in on the document so smaller text etc will be easier to read. To zoom in further, click the icon again. If the menu bar is not visible then use your mouse by clicking the left hand button and moving it.



This will zoom out of the document. To zoom out further, click the icon again. If the menu bar is not visible then use your mouse by clicking the left hand button and moving it.



This will print out the full brochure to your printer. Please note that if you have a colour printer this document will print in full colour.



This will save the whole document to your computer.

To close this document press *esc* and then close the document normally.

Whilst every effort is made to reproduce accurate information, we reserve the right to change specifications, equipment and availability without prior notice. This brochure cannot be regarded as infallible, (some of the vehicles shown may not be to exact UK specification), and as such does not constitute an offer for sale of any particular vehicle or specification. For the latest specification and availability we ask that you contact your local Toyota Centre.



home



previous



next



index



show menu



print



zoom in



zoom out



save



help



TODAY TOMORROW TOYOTA