

January 2010



Panel vans and kombis



Welcome.

Over the years, we've worked hard to establish Volkswagen Commercial Vehicles as a dependable, well-respected Brand. There is an indefinable robustness that distinguishes both our products and our organisation from others. It's founded in the twin reality of premium quality vehicles on the road, and down-to-earth assistance in our day-to-day dealings with our customers. We want you to have the confidence that wherever you are, whatever business you're in, Volkswagen can be relied on to deliver.

But we're not complacent. We are still working to improve our network of Van Centres, the product range and, of course, the level of customer care. We want to help you find the right vehicle for your business, and the right level of support for you. So if you need assistance, please, just ask.



Contents.



02 - 07
Welcome to Volkswagen Commercial Vehicles, introduction and importantly your quick reference guide.



08 - 13
The panel van and kombi range – which model is for me?



14 - 15
A summary of the panel van and kombi range.



16 - 33
The Volkswagen Caddy and Caddy Maxi van, standard specifications, prices, factory options and technical data.



34 - 41
The Caddy Maxi kombi.

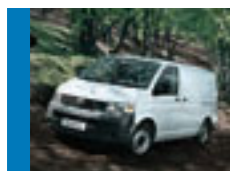

42 - 55
The new Volkswagen Transporter panel van, standard specifications, prices, factory options and technical data.



56 - 69
The new Volkswagen Transporter kombi.



70 - 85
The Volkswagen Crafter panel van, standard specifications, prices, factory options and technical data.

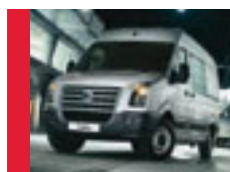

86 - 99
The Volkswagen Crafter kombi, standard specifications, prices, factory options and technical data.



100 - 103
Paint and upholstery for the panel van and kombi range and a comprehensive choice of Volkswagen Commercial Vehicle accessories.



104 - 107
Services, warranties, glossary and our dedicated Van Centre network.



Introduction.

So you're thinking about a new van. What does it need to carry? How heavy is the load you will put in it? How important is fuel consumption? What about servicing, warranties, available accessories and, of course, finance options?

All these, and many other questions, need to be answered before you can make an informed decision. One that's right for your business.

And because the Volkswagen Commercial Vehicles panel van and kombi range gives you such a wide choice, you're sure to get exactly what you need.

This brochure aims to make that process as easy as possible. We suggest you keep the 'Quick reference guide' pages open as you browse to help you in your choice. So let's go to work...

Panel van and kombi quick reference guide.

Model and price guide*	Volume m ³	Payload range kg
Caddy van £11,400.00 – £17,650.00		718 to 739
Caddy Maxi kombi £13,900.00 – £15,700.00		620 to 671
Caddy Maxi van £13,600.00 – £18,930.00		724 to 742
New Transporter short wheelbase with low roof £15,700.00 – £23,850.00		749 to 1,333
New Transporter kombi short wheelbase with low roof £17,880.00 – £21,880.00		1,024 to 1,224
New Transporter short wheelbase with optional medium roof £16,120.00 – £24,270.00		749 to 1,333
New Transporter kombi short wheelbase with optional medium roof £18,300.00 – £22,300.00		1,024 to 1,224
New Transporter long wheelbase with low roof £16,890.00 – £24,340.00		925 to 1,272
New Transporter kombi long wheelbase with low roof £19,470.00 – £22,570.00		1,136 to 1,202
Crafter short wheelbase with low roof £18,000.00 – £19,200.00		936
New Transporter long wheelbase with optional medium roof £17,310.00 – £24,760.00		925 to 1,272
New Transporter kombi long wheelbase with optional medium roof £19,890.00 – £22,990.00		1,136 to 1,202
Crafter medium wheelbase with optional low roof £22,000.00 – £29,360.00		<small>Please note: Roof options alter payload, please ask your Volkswagen Van Centre.</small>
Crafter kombi medium wheelbase with optional low roof £23,450.00 – £28,270.00		<small>Please note: Roof options alter payload, please ask your Volkswagen Van Centre.</small>



* Prices exclude VAT, OTR package and optional equipment other than roof packs where applicable.
 ** Maxi = extended rear overhang.
 † Passenger seats in rear are not excluded from volume.

Model and price guide*	Volume m ³	Payload range kg
New Transporter long wheelbase with optional high roof £17,615.00 – £25,065.00		925 to 1,272
New Transporter kombi long wheelbase with optional high roof £20,300.00 – £23,400.00		1,136 to 1,202
Crafter medium wheelbase with high roof £22,800.00 – £30,160.00		1,312 to 2,528
Crafter kombi medium wheelbase with high roof £24,250.00 – £29,070.00		1,215 to 2,431
Crafter medium wheelbase with optional extra high roof £23,980.00 – £31,615.00		<small>Please note: Roof options alter payload, please ask your Volkswagen Van Centre.</small>
Crafter kombi medium wheelbase with optional extra high roof £25,430.00 – £30,525.00		<small>Please note: Roof options alter payload, please ask your Volkswagen Van Centre.</small>
Crafter long wheelbase with high roof £23,350.00 – £30,760.00		1,179 to 2,361
Crafter kombi long wheelbase with high roof £25,070.00 – £29,890.00		1,057 to 2,241
Crafter long wheelbase with optional extra high roof £24,530.00 – £32,215.00		<small>Please note: Roof options alter payload, please ask your Volkswagen Van Centre.</small>
Crafter kombi long wheelbase with optional extra high roof £26,250.00 – £31,345.00		<small>Please note: Roof options alter payload, please ask your Volkswagen Van Centre.</small>
Crafter long wheelbase maxi** with high roof £24,800.00 – £31,260.00		1,127 to 2,317
Crafter kombi long wheelbase maxi** with high roof £25,610.00 – £30,430.00		996 to 2,188
Crafter long wheelbase maxi** with optional extra high roof £25,980.00 – £32,715.00		<small>Please note: Roof options alter payload, please ask your Volkswagen Van Centre.</small>
Crafter kombi long wheelbase maxi** with optional extra high roof £26,790.00 – £31,885.00		<small>Please note: Roof options alter payload, please ask your Volkswagen Van Centre.</small>



* Prices exclude VAT, OTR package and optional equipment other than roof packs where applicable.
 ** Maxi = extended rear overhang.
 † Passenger seats in rear are not excluded from volume.

The Volkswagen panel van and kombi range.

What a range this is! For starters, we're the only manufacturer with an automatic gearbox on a diesel engine available across the whole of the range. Not only that, we also have a whole host of engine options, seating options, equipment options and so on. But with such a wide range to choose from, which is the right vehicle for you? After all, we have everything from the compact Caddy to the enormous Crafter long wheelbase maxi model with its extra high roof, all with different payloads and volumes.

The range now includes the Caddy Maxi panel van, which sits neatly into the spread of carrying capabilities of the Volkswagen panel van range; the new Caddy Maxi kombi, with a choice of passenger or load configurations; and the new Crafter kombi, with room for up to five people, and plenty of space for carrying equipment to site each day. There's also the new Transporter kombi and panel van, offering greater comfort, functionality, efficiency and flexibility than ever before.

Dependability is built into the very fabric of the Volkswagen Commercial Vehicles range. As is quality. Which means you can be absolutely certain that whichever model you finally choose, it will do the job, day in, day out. To get you started, here are a few of the benefits that come as standard:

- UK-wide Van Centre network support
- Finance options tailored to suit your business
- Payloads from 720kg all the way up to 2,603kg
- Load volumes from 3.2m³ to 17.0m³
- Value-for-money parts
- LongLife servicing
- Free 3-year Volkswagen Roadside Assistance
- Wide range of accessories for all models
- High residual values*.

* According to industry influencers.



Safety is a priority.

Your safety is such a vital factor that it is built-in, both with the integral construction of the vehicles, and in the features we include to protect the occupants. A long list of safety and security features applies to every vehicle, but may vary according to model specifications.

Features such as the 4MOTION® all wheel drive system to maintain traction in poor driving conditions, front and rear parking sensors, and anti-theft protection for added security, all offer particular assistance and protection when you're out on the road. Passive safety features include a driver's airbag, which is standard across the range with the option of passenger, side and curtain airbags.

These are some of the safety features available, but please refer to particular model specifications for which feature is available on which model:

- ABS*
- TCS*
- EBC*
- EBD*
- ESP* as standard on new Transporter panel van and kombi
- Driver and passenger airbags
- Side and curtain airbags
- Third brake light
- Bulkhead as standard on Caddy, Caddy Maxi and Crafter vans
- Automatic hazard lights activation under emergency braking standard on new Transporter and Crafter.

Add to all these independent suspension, stable road holding and responsive engines and you can be sure that you'll be as safe as we can make you. The rest is up to you!

* Please refer to the glossary on page 106 of this brochure.





So which model is for me?

You probably already know roughly what you'll need to carry. What is the biggest thing you'll need to get in your vehicle, or the heaviest, or the longest or just the most awkward? If you're a fleet manager, then you'll probably need a variety of options!



Having this in mind should help you get quickly to either the Volkswagen Caddy and Caddy Maxi, new Transporter or Crafter ranges as a starting point. Remember though that there is some cross-over between the ranges, and for example, the smallest Crafter may be more suitable than the biggest new Transporter, or a new Transporter may be more suitable than the Caddy Maxi. Please refer to the handy 'Quick Reference Guide' on page 6.











Remember, this brochure only covers panel vans and kombis, together with their factory-fitted options. There are separate brochures available for our chassis and double cab, and passenger-carrier ranges. There is also an accessories brochure for you to further enhance your van.

Now let's take a more detailed look at each model in the panel van range so you can begin to make your choice...





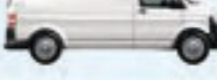











Summary of the Volkswagen panel van and kombi range.

Model	Gross vehicle weight kg	Wheelbase mm	Panel van low roof		
Caddy, Caddy Maxi and Caddy Maxi kombi.					
Caddy	up to 2,240*	2,682			
Caddy Maxi	up to 2,350*	3,002			
Caddy Maxi kombi	up to 2,360*	3,002			

Model	Gross vehicle weight kg	Wheelbase mm	Panel van low roof	Panel van medium roof	Panel van high roof
New Transporter and new Transporter kombi.					
T26	2,600	3,000			
T28	2,800	3,000			
T30	3,000	3,000			
		3,400			
T32	3,200	3,000			
		3,400			



Model	Gross vehicle weight kg	Wheelbase mm	Panel van/kombi low roof	Panel van/kombi high roof	Panel van/kombi extra high roof
Crafter and Crafter kombi.					
CR30	3,000	3,250			
CR35	3,500	3,665			
		4,325			
		4,325 maxi†			
CR50	5,000	3,665			
		4,325			
		4,325 maxi†			

* Depending on engine and gearbox fitted.
 † Maxi = extended rear overhang.
 □ Indicates models fitted with optional equipment.



The Volkswagen Caddy and Caddy Maxi.

Load floor showing accommodation of euro-pallet.

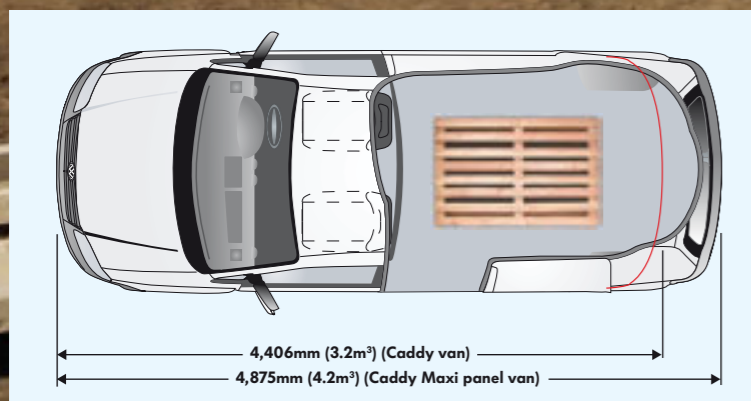

The Caddy van may be the most compact in the panel van range, but it's very versatile, and will carry loads of up to 724kg with a generous load space of 3.2m³.

The Caddy Maxi panel van is its larger sibling, designed to carry even larger payloads and extending the carrying capacity to 800kg, but more importantly offering greater load space up to a whopping 4.2m³.

Getting your load in and out couldn't be easier as both Caddy models have asymmetric twin rear doors and a wide sliding side door, while the Caddy Maxi benefits from a second sliding door as standard, (optionally available on the Caddy van).

Apart from standard safety features such as built-in bulkhead protection and 6 load-lashing rings to secure your load safely, both Caddy variants include a host of features, such as a CD player fitted as standard, ensuring they're also great to drive!

Featuring such innovations as modified gear ratios and low-friction tyres, the Caddy BlueMotion Technology is both environmentally friendly and economical to run, with the 1.9 TDI diesel engine producing lower CO₂ emissions than any other comparable diesel – just 149g/km – yet achieving a powerful 104PS.

BLUEMOTION
— TECHNOLOGIES —

A full list of features can be found on the following pages, but this is an overview of what the Caddy and Caddy Maxi have to offer:

- Load volume up to 4.2m³
- Payload up to 800kg
- Asymmetric rear doors
- 700mm wide sliding side door
- Full height bulkhead
- Choice of up to four diesel engines
- ABS*, EBC*, EBD* and TCS*.

Vehicle weights and dimensions are shown on page 24 and 25. Other features and specifications are detailed on pages 18 and 19.

* Please refer to the glossary on page 106 of this brochure.



Volkswagen Caddy and Caddy Maxi standard specifications.

Body.

- 60 litre lockable fuel tank
- Black wheel centre caps
- Externally adjustable exterior mirrors:
 - Convex on passenger's side
 - Aspherical on driver's side
- Front and rear towing eyes
- Grey bumpers
- Heat reflective glass
- Jack and tool kit with steel spare wheel (except BlueMotion Technology)
- Partially galvanised all-steel body
- Roof load rack preparation

Interior.

- | | | |
|--|--|--|
| <p>Cab area:</p> <ul style="list-style-type: none"> • 2 folding and pivoting sun visors • Driver's seat with height, reach and rake adjustment • Grab handles on roof frame • 'Inca' fabric seat covers • Interior light in headliner • Passenger seat with reach and rake adjustment | <ul style="list-style-type: none"> • Rubber floor covering • Storage: <ul style="list-style-type: none"> - 2 storage trays in dash panel - 4 drinks holders and storage compartment in centre console - Open glove compartment - Overhead storage | <p>Rear:</p> <ul style="list-style-type: none"> • 2 door-activated interior lights • Half-height load side lining in painted hardboard • Interior roof trim in hardboard • Load sill protection • Sheet steel flooring |
|--|--|--|

Functional.

- | | | |
|--|---|--|
| <ul style="list-style-type: none"> • 12V socket • Digital clock • Dimmable dashboard illumination • Manually controlled heating system with dust and pollen filter and air recirculation | <ul style="list-style-type: none"> • Radio/single CD player, MP3 compatible with 2 wideband speakers • Remote central locking with deadlocks, internal locking switch and 1 remote key • Rev counter | <ul style="list-style-type: none"> • Warning buzzer for lights left on • Windscreen wiper with variable intermittent delay and wash/wiper system |
|--|---|--|

Technical.

- | | | |
|--|---|---|
| <ul style="list-style-type: none"> • Front and rear axle: <ul style="list-style-type: none"> - Anti-roll bars, front and rear - Front McPherson strut suspension - Rear rigid axle with single layer leaf springs - Telescopic shock absorbers | <ul style="list-style-type: none"> • Hydraulic brake system with disc brakes and ABS: Anti-lock Braking System • Power steering – hydraulic (on 69PS and 104PS engines) • Power steering – electro-mechanical speed dependent, servotronic (on 140PS engine) | <ul style="list-style-type: none"> • Steel wheels: 6.0J x 15 (on 69PS* and 104PS engines)
6.0J x 16 (on 140PS engine) • Tyres: 195/65 R15 (on 69PS* and 104PS engines)
205/55 R16 (on 140PS engine) |
|--|---|---|

Safety and security.

- | | | |
|--|--|--|
| <ul style="list-style-type: none"> • 3rd brake light • ABS: Anti-lock Braking System • Breaksafe steering wheel lock • Driver's airbag • EBC: Engine Braking Control • EBD: Electronic Brakeforce Distribution | <ul style="list-style-type: none"> • Electronic immobiliser 'Transponder' • Halogen main headlights with range control • Height adjustable head restraints • Height and rake adjustable safety steering column • Load lashing rings (6) | <ul style="list-style-type: none"> • Rear fog lights • Rear-view mirror with anti-dazzle function • TCS: Traction Control System • Three-point, height adjustable and tensioning inertia reel seat belts |
|--|--|--|

Model specific features.

Caddy.

- | | |
|--|---|
| <ul style="list-style-type: none"> • Glazed asymmetric rear-wing doors • Full height bulkhead - solid lower and plastic mesh upper | <ul style="list-style-type: none"> • Heated rear window with rear wash/wipe on larger rear door • Side sliding door on left |
|--|---|

Caddy Maxi.

- | | |
|--|---|
| <ul style="list-style-type: none"> • Glazed (opaque glass) asymmetric rear-wing doors | <ul style="list-style-type: none"> • Full height bulkhead - solid • Side sliding door on left and right |
|--|---|

Caddy BlueMotion Technology.

- As Caddy except:
- Cruise control
 - Trip computer
 - Tyre repair kit and compressor

* 69PS engine not available on Caddy Maxi models.



Caddy Maxi full height bulkhead.



Radio/CD player.



Overhead storage.



Caddy rear wing doors.



Load lashing rings.



Side sliding door. Image shows Caddy full height bulkhead.

The Caddy Maxi van.
Always ready to deliver.



Volkswagen Caddy and Caddy Maxi recommended retail prices.

Model	Manufacturer's RRP					Ins. group**		
	Basic retail excluding VAT £ †	VAT £ †	Total retail including VAT £ †	Total retail including OTR* excluding VAT £ †	Total retail including OTR* including VAT £ †			
Caddy van.								
C20	69PS SDI PD 2.0 l 2KAA32		11,400.00	1,995.00	13,395.00	14,304.75	3E-T2	
	104PS TDI PD 1.9 l 2KAA42		12,320.00	2,156.00	14,476.00	15,385.75	3E-T2	
	104PS TDI PD DSG 1.9 l 2KAA43		13,320.00	2,331.00	15,651.00	16,560.75	3E-T2	
	104PS TDI PD BlueMotion Technology 1.9 l 2KAA4A		13,270.00	2,322.25	15,592.25	14,080.00	16,502.00	4E-T2
	140PS TDI PD 2.0 l 2KAA64		14,120.00	2,471.00	16,591.00	14,930.00	17,500.75	4A-T2
	140PS TDI PD Sportline 2KAS64		17,650.00	3,088.75	20,738.75	18,460.00	21,648.50	5E-T2
Caddy Maxi panel van.								
C20	104PS TDI PD 1.9 l 2KHA42		13,600.00	2,380.00	15,980.00	14,410.00	16,889.75	4A-T2
	104PS TDI PD DSG DPF 1.9 l 2KHA43		15,000.00	2,625.00	17,625.00	15,810.00	18,534.75	4A-T2
	140PS TDI PD DPF 2.0 l 2KHA64		15,400.00	2,695.00	18,095.00	16,210.00	19,004.75	4A-T2
	140PS TDI PD Sportline 2KHS64		18,930.00	3,312.75	22,242.75	19,740.00	23,152.50	5E-T2

*OTR (on the road) package includes the following:
 Delivery to retailer £550.00
 Number plates £20.00
 VAT £99.75
 Road fund licence £185.00
 First registration fee £55.00
Total £909.75

† Calculated at 17.5% on all products.

** Insurance group: As advised by the Association of British Insurers (ABI).
 Please see www.thatcham.org/abigrouprating for more information.

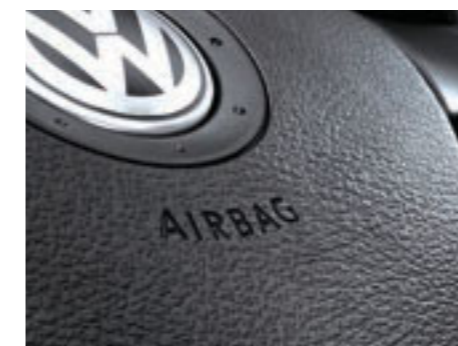

Driver's airbag.



Third brake light.



Load side lining.

Models subject to availability.

Volkswagen Caddy and Caddy Maxi factory options.

	Caddy van	Caddy Maxi panel van	Manufacturer's RRP		
			Basic retail excluding VAT £ †	VAT £ †	Total retail including VAT £ †
Paint options.					
Metallic paint	•	•	315.00	55.13	370.13
Black paint - 9000	•	•	280.00	49.00	329.00
Pearl paint	•	•	330.00	57.75	387.75
Danish blue paint - 9506	•	•	105.00	18.38	123.38
Friesen green paint - 9644	•	•	105.00	18.38	123.38
Factory fitted options.					
Alloy wheels - 15", 4 with steel spare (not 140PS)	•	•	390.00	68.25	458.25
Alloy wheels - 16", 4 with steel spare (140PS only)	•	•	670.00	117.25	787.25
Appearance pack - body coloured bumpers and wing mirrors (only with electric pack) ¹	•	•	200.00	35.00	235.00
AUX-IN socket - for connection to external multimedia source (not with satellite navigation)	•	•	25.00	4.38	29.38
Cruise control (standard on BlueMotion Technology)	•	•	185.00	32.38	217.38
ESP plus ²	•	•	260.00	45.50	305.50
Fog lights - front (included in visibility pack A)	•	•	110.00	19.25	129.25
Key - 2nd, for remote locking (included with alarm packs A and B)	•	•	10.00	1.75	11.75
Ladder flap - in roof (only with side door pack A, not with rear door pack B)	•	•	210.00	36.75	246.75
Load floor cover - rubber	•	•	85.00	14.88	99.88
Parking sensors - rear	•	•	230.00	40.25	270.25
Satellite navigation A - colour touch screen (CD), includes trip computer ³ (not with AUX-IN socket)	•	•	800.00	140.00	940.00
Steering wheel - leather trimmed, multi-function with trip computer	•	•	290.00	50.75	340.75
Towbar - fixed ball with 13 pin socket ⁴	•	•	325.00	56.88	381.88
Trip computer (included with satellite navigation and steering wheel - leather) (standard on BlueMotion Technology)	•	•	120.00	21.00	141.00
Tyres - all weather (not BlueMotion Technology)	•	•	110.00	19.25	129.25

Options packs.

Alarm pack A - perimeter with back-up horn (includes 2nd key for remote locking)	•	•	140.00	24.50	164.50
Alarm pack B - with interior (cab only) and tow away protection (includes 2nd key for remote locking)	•	•	170.00	29.75	199.75
Cab comfort pack ⁵	•	•	235.00	41.13	276.13
Electric pack - electric windows and electrically heated and adjustable mirrors	•	•	280.00	49.00	329.00
Smoking pack - ashtray and cigarette lighter	•	•	15.00	2.63	17.63
Visibility pack A - front fog lights, headlight washers, heated washer jets and washer fluid level indicator	•	•	290.00	50.75	340.75



15" alloy wheels.



Fog lights.



Rubber floor covering.

	Caddy van	Caddy Maxi panel van	Manufacturer's RRP		
			Basic retail excluding VAT £ †	VAT £ †	Total retail including VAT £ †
Options packs. (continued)					
Visibility pack B - rain sensor, automatic dimming rear view mirror and 'coming home' function	•	•	105.00	18.38	123.38
Airbag packs.					
Airbag pack A - front passenger with deactivation	•	•	185.00	32.38	217.38
Airbag pack B - front passenger with deactivation and side airbags	•	•	345.00	60.38	405.38
Airbag pack D - front passenger with deactivation and thorax head airbags	•	•	485.00	84.88	569.88
Bulkhead packs.					
Bulkhead pack A - deleted	•	•	0.00	0.00	0.00
Door packs.					
Rear door pack A - wing doors with opaque glass, without heated rear window and wash/wipe	•	•	0.00	0.00	0.00
Rear door pack B - tailgate with heated rear window and wash/wipe (not with ladder flap)	•	•	0.00	0.00	0.00
Side door pack A - left and right	•	•	250.00	43.75	293.75
Heating and ventilation.					
Air conditioning - 'Climatic', semi-automatic	•	•	780.00	136.50	916.50
Seat packs.					
Seats - leatherette upholstery	•	•	25.00	4.38	29.38
Seats - 'Robust' upholstery	•	•	40.00	7.00	47.00
Seat pack A - heated driver and front passenger seats	•	•	205.00	35.88	240.88

- Options.
- Not available.

† Calculated at 17.5% on all products.

¹ **Appearance pack:** Restricted colours, please confirm availability with your Volkswagen Van Centre.

² **ESP plus:** Includes Driver Steering Response (DSR) and trailer stabilisation function.

³ **Satellite navigation A:** Replaces radio, includes RDS radio function with single CD (audio CDs cannot be played when using navigation disc).

⁴ **Towbars:** On BlueMotion Technology model the spare wheel is replaced with a tyre repair kit. An adaptor is available from Van Centres, to allow connection to twin 7 pin sockets.

⁵ **Cab comfort pack:** Cab carpet, height adjustable front seats, storage under front seats, vanity mirrors and dash tray with cover.



Ladder flap for Caddy van.



'Climatic' air conditioning.



Towbar.

Options subject to availability.

Caddy van dimensions and weights.

Caddy van.

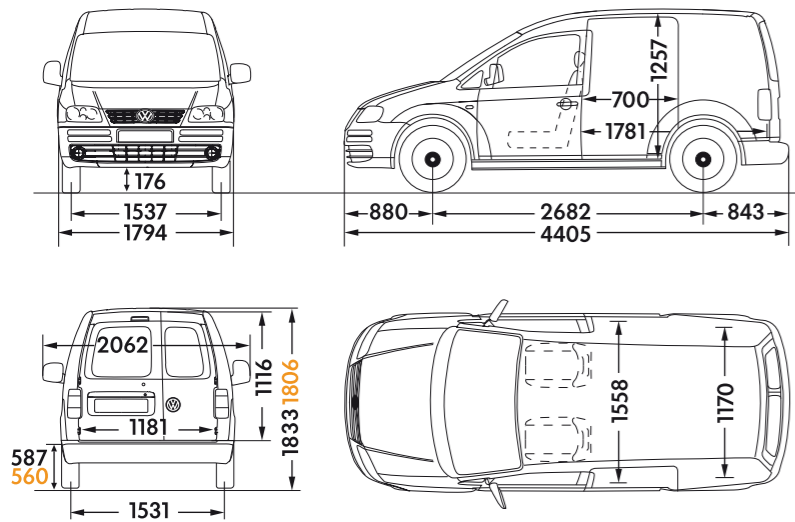

Wheelbase		2,682
Load compartment	length ¹	1,781
	width	1,558
	height	1,257
	volume	3.2m ³
Lateral sliding door	width	700
	height	1,108
Rear wing doors	width	1,181
	height	1,116
Turning circle (wall to wall)		11.1m

¹ With bulkhead (half-height, with plastic mesh upper)
 Figures in orange indicate BlueMotion Technology dimensions, where different.
 Dimensions in mm unless otherwise indicated.

Caddy Maxi van dimensions and weights.

Caddy Maxi panel van.

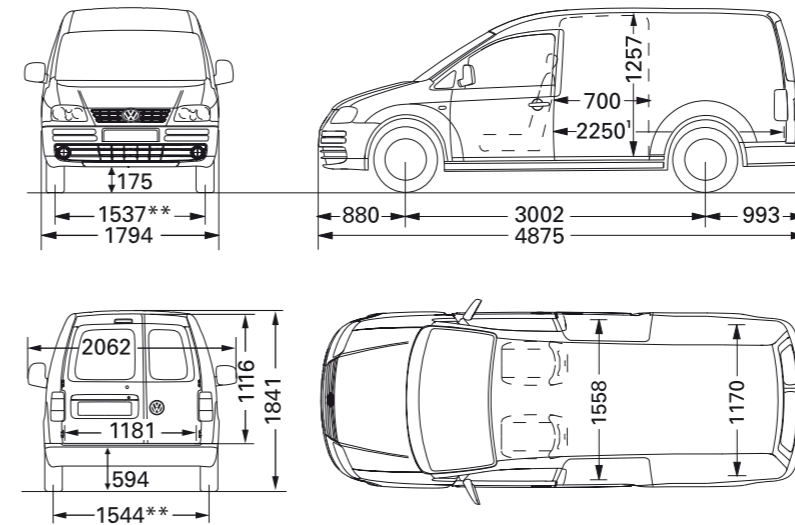

Wheelbase		3,002
Load compartment	length ¹	2,250
	width	1,558
	height	1,257
	volume	4.2m ³
Lateral sliding door	width	700
	height	1,108
Rear wing doors	width	1,181
	height	1,116
Turning circle (wall to wall)		12.2m

¹ With solid bulkhead.
^{**} -6mm, depending on wheel size.
 Dimensions in mm unless otherwise indicated.

The height measurements listed here can differ by approx. ± 50mm depending on equipment.

Model	Gross vehicle weight kg	Engine	Axle load limit front / rear kg	Trailer weight braked / unbraked ² kg	Gross train weight kg	Unladen [†] weight kg	Payload [†] kg
C20	2,185	69PS SDI PD	2.0 I 1,050 / 1,230	1,325 / 720	3,500	1,465	739
	2,211	104PS TDI PD	1.9 I 1,065 / 1,230	1,425 / 740	3,500	1,491	720
	2,240	104PS TDI PD DSG	1.9 I 1,090 / 1,230	1,425 / 750	3,500	1,522	718
	2,130	104PS TDI PD					
		BlueMotion Technology	1.9 I 1,110 / 1,100	1,500 / 720	3,500	1,489	641
	2,222	140PS TDI PD	2.0 I 1,075 / 1,230	1,500 / 740	3,500	1,521	701
	2,222	140PS TDI PS Sportline	2.0 I 1,075 / 1,230	1,500 / 740	3,500	1,545	677

Model	Gross vehicle weight kg	Engine	Axle load limit front / rear kg	Trailer weight braked / unbraked ² kg	Gross train weight kg	Unladen [†] weight kg	Payload [†] kg
C20	2,315	104PS TDI PD	1.9 I 1,110 / 1,300	1,500 / 750	3,500	1,573	742
	2,350	104PS TDI PD DSG	1.9 I 1,170 / 1,300	1,500 / 750	3,500	1,609	741
	2,342	140PS TDI PD	2.0 I 1,165 / 1,300	1,500 / 750	3,500	1,602	740
	2,342	140PS TDI PD Sportline	2.0 I 1,165 / 1,300	1,500 / 750	3,500	1,618	724

Roof load limit: 100kg.

Trailer nose weight limit: 80kg.

² For 12% gradient.

[†] Unladen weight and payload includes approximately 90% fuel load and 75kg for driver.

Payload = gross vehicle weight - unladen weight.

Weights are for vehicles with standard specification. The addition of factory options or Volkswagen Van Centre fitted accessories may affect unladen weight and payload.

Caddy van fuel consumption and performance.

Engine	Urban ³ mpg (l/100km)	Extra urban ³ mpg (l/100km)	Combined ³ mpg (l/100km)	Acceleration 0-62 mph	Top speed (where the law permits) mph
Caddy van.					
69PS SDI PD	2.0 I 38.2 (7.4)	54.3 (5.2)	47.1 (6.0)	20.1	88
104PS TDI PD	1.9 I 38.7 (7.3)	53.3 (5.3)	47.1 (6.0)	13.0	103
104PS TDI PD DSG	1.9 I 34.4 (8.2)	49.6 (5.7)	42.8 (6.6)	13.0	103
104PS TDI PD					
BlueMotion Technology	1.9 I 39.2 (7.2)	58.8 (4.8)	49.6 (5.7)	13.0	106
140PS TDI PD	2.0 I 36.7 (7.7)	52.3 (5.4)	45.6 (6.2)	10.1	116
140PS TDI PD Sportline	2.0 I 36.7 (7.7)	52.3 (5.4)	45.6 (6.2)	10.1	116

Caddy Maxi van fuel consumption and performance.

Engine	Urban ³ mpg (l/100km)	Extra urban ³ mpg (l/100km)	Combined ³ mpg (l/100km)	Acceleration 0-62 mph	Top speed (where the law permits) mph
Caddy Maxi van.					
104PS TDI PD	1.9 I 38.2 (7.4)	54.3 (5.2)	47.1 (6.0)	13.3	102
104PS TDI PD DSG	1.9 I 34.4 (8.2)	47.9 (5.9)	41.5 (6.8)	13.3	103
140PS TDI PD	2.0 I 36.7 (7.7)	52.3 (5.4)	45.6 (6.2)	10.5	116
140PS TDI PD Sportline	2.0 I 36.7 (7.7)	52.3 (5.4)	45.6 (6.2)	10.5	116

³ With 50% payload.

The performance figures listed above apply to vehicles with 5-speed or 6-speed manual gearbox and DSG semi-automatic gearbox, without optional extras.

The Caddy van.
A skilled performer.



Caddy and Caddy Maxi engine specifications.

	69PS SDI PD ¹	104PS TDI PD	104PS TDI PD BlueMotion Technology	140PS TDI PD
Engine type	Transverse, water cooled in line	Transverse, water cooled in line, variable geometry turbocharger with intercooler		
Mixture preparation/injection method	Unit injector pump direct injection			
EU exhaust emission standard	4			
No. of cylinders	4			
Cubic capacity, cm ³	1,968	1,896	1,896	1,968
Output, PS at rpm	69 at 4,200	104 at 4,000	104 at 4,000	140 at 4,000
Torque, max. Nm/rpm	140/2,200	250/1,900	250/1,900	320/1,800 – 2,500
Diesel Particulate Filter (DPF)	-	- ²	•	•
5-speed manual gearbox	•	•	•	-
6-speed manual gearbox	-	-	-	•
6-speed semi-automatic	-	-	-	-
DSG gearbox	-	•	-	-
Front wheel drive	•	•	•	•

Electrics.

Alternator (all variants)

110A

Battery

61Ah (330A)

- Available
- Not available

¹ 69PS SDI PD diesel engine is not available for the Caddy Maxi

² The 104PS TDI PD diesel engine with 6-speed DSG semi-automatic gearbox is equipped with a Diesel Particulate Filter (DPF) as standard on Caddy Maxi

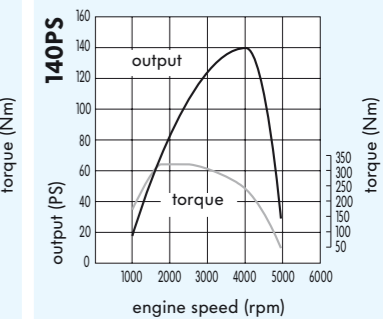
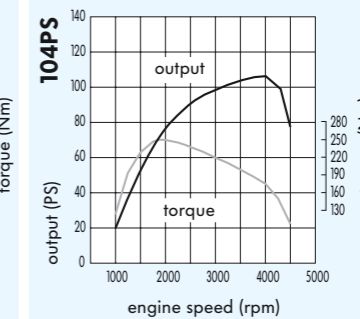
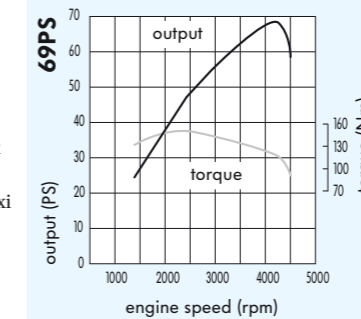

Direct Shift Gearbox.

The award winning and highly acclaimed Direct Shift Gearbox (DSG) is unique to the commercial vehicle market and operates with two automatic clutches – while one is engaged, the other is ready and to accept the next gear. This twin clutch technology means you can change gear much faster than with a standard automatic gearbox – actually in less than four hundredths of a second.

This means that for stop-start round city work the DSG comes into its own, making life much easier for the driver. Of course you can still change gear manually if you prefer!



Caddy and Caddy Maxi Sportline. Stand out from the crowd.

A whole host of enhancements set both the Volkswagen Caddy Sportline and the Volkswagen Caddy Maxi Sportline apart from the crowd. Both models have the top-of-the-range 140PS diesel engine and a smooth 6-speed gearbox, providing huge power and workload capability.

The Caddy Sportline has a maximum payload of 677kg with a load space of 3.2m³, one side sliding door, and bulkhead with upper mesh panel whilst the Caddy Maxi Sportline carries a whopping 724kg payload in a cavernous 4.2m³ load space. It also boasts a sliding door on both sides, providing maximum flexibility in loading, and a full height solid bulkhead.

One glance will identify these models as a little bit special. Colour-coded bumpers, mirrors and door handles, lower front spoiler, rear roofline spoiler, integrated front fog lights, chrome front grilles and the bespoke 17" 6-spoke alloy wheels have a Sportline centre logo which all add to the sporty feel. The chrome side rails not only look good, they also protect the sills from damage. There's a choice of Tornado Red, Reflex Silver metallic or Diamond Black pearl paint finishes to complement your personality.



- 01** Superb sound from a RCD 310 Radio/CD player, MP3 compatible with 2 wideband speakers. Includes AUX-IN socket.
- 02** Stylish, bespoke Sportline badge.
- 03** Electric front windows.
- 04** Full height bulkhead – solid lower with plastic mesh upper on Caddy Sportline.
- 05** Sportline models can be specified in Tornado Red (or Reflex Silver metallic and Diamond Black pearl which are available at extra cost).

Caddy and Caddy Maxi Sportline. Be distinctive: elevate your profile.

The chrome side rails, colour-coded handles and alloy wheels make the Sportline distinctive. However, the all round exterior styling is only part of the package. The interior is a bit special too, with the seats being upholstered in premium grade, hand-crafted black Italian leather using red stitching, micro perforated centre panels and an exclusive embroidered Sportline logo.

But it is more than just the Sportline styling that makes these models a bit different. The driver's compartment is ergonomically laid out, and additional touches are easily apparent. Both models are equipped with 'Climatic' air conditioning, an RCD 310 Radio/CD unit featuring an AUX-IN socket for connection to an external multimedia source such as MP3 player and iPod, and conveniently located controls for the electronic front windows and the electronically adjustable and heated mirrors.

Safety is paramount too, with ABS (Anti-lock Braking System), TCS (Traction Control System) and EBC (Engine Braking Control) all coming as standard. A driver's airbag is also fitted as well as all the appropriate safety measures you would expect from a Volkswagen Commercial Vehicle.

So when you need a good balance between work and pleasure, the Sportline range is the perfect choice.



- 06** Opaque glass on rear doors of Caddy and Caddy Maxi Sportline, image also shows the rear roofline spoiler.
- 07** Elegant body-coloured front bumper with sporty lower front spoiler.
- 08** Sumptuous hand-crafted black Italian leather seats with perforated centre panels and embroidered Sportline logo.
- 09** 17" 6-spoke alloy wheels enhanced with Sportline centre caps.
- 10** Solid full height bulkhead on Caddy Maxi Sportline.

Caddy and Caddy Maxi Sportline standard specifications.

Body.

- | | | |
|--|--|---|
| <ul style="list-style-type: none"> • Bumpers, body-coloured • Door handles, body-coloured • Exterior mirrors: <ul style="list-style-type: none"> - Aspherical on driver's side - Body-coloured - Convex on passenger's side - Electrically adjustable and heated | <ul style="list-style-type: none"> • Fuel tank, lockable (60 litre capacity) • Glazed (opaque glass) asymmetric rear-wing doors • Heat reflective glass • Partially galvanised all-steel body • Roof load rack preparation • Tyre repair kit | Items fitted by Volkswagen approved supplier¹: <ul style="list-style-type: none"> • Centre wheelcaps with Sportline decal • Chrome side rails • Lower front spoiler • Rear roofline spoiler • Sportline badge, rear • Upper and lower chrome grilles, front |
|--|--|---|

Interior.

- | | | |
|---|---|---|
| Cab area: <ul style="list-style-type: none"> • 2 folding and pivoting sun visors • Driver's seat with height, reach and rake adjustment • Grab handles on roof frame • Interior light in headliner • Passenger seat with reach and rake adjustment • Rubber floor covering | Storage: <ul style="list-style-type: none"> - 2 storage trays in dash panel - 4 drinks holders and storage compartment in centre console - Open glove compartment - Overhead storage | Rear: <ul style="list-style-type: none"> • 2 door-activated interior lights • Half-height load side lining in painted hardboard • Interior roof trim in hardboard • Load sill protection • Sheet steel flooring |
| Item fitted by Volkswagen approved supplier¹: <ul style="list-style-type: none"> • Black and red leather upholstery with Sportline logo | | |

Functional.

- | | | |
|--|---|---|
| <ul style="list-style-type: none"> • 12V socket • AUX-IN socket for connection to external multimedia source • 'Climatic' semi-automatic air conditioning • Digital clock • Dimmable dashboard illumination | <ul style="list-style-type: none"> • Electric, heated exterior mirrors • Electric windows • Radio/single CD player, MP3 compatible with 2 wideband speakers • Remote central locking with deadlocks, internal locking switch and 1 remote key | <ul style="list-style-type: none"> • Rev counter • Warning buzzer for lights left on • Windscreen wiper with variable intermittent delay and wash/wiper system |
|--|---|---|

Running gear.

- | | | |
|--|---|--|
| <ul style="list-style-type: none"> • Front and rear axle: <ul style="list-style-type: none"> - Anti-roll bars, front and rear - Front McPherson strut suspension - Rear rigid axle with single layer leaf springs - Telescopic shock absorbers | <ul style="list-style-type: none"> • Hydraulic brake system with disc brakes and ABS: Anti-lock Braking System • Power steering – electro-mechanical speed dependent, servotronic | Items fitted by Volkswagen approved supplier¹: <ul style="list-style-type: none"> • 17" 6-spoke alloy wheels • Tyres: 225/45/ZR17 94 Y |
|--|---|--|

Safety and security.

- | | | |
|--|--|--|
| <ul style="list-style-type: none"> • 3rd brake light • ABS: Anti-lock Braking System • Breaksafe steering wheel lock • Driver's airbag • EBC: Engine Braking Control • EBD: Electronic Brakeforce Distribution | <ul style="list-style-type: none"> • Electronic Immobiliser 'Transponder' • Front fog lights • Halogen main headlights with range control • Height adjustable head restraints • Height and rake adjustable safety steering column | <ul style="list-style-type: none"> • Load lashing rings (6) • Rear fog lights • Rear-view mirror with anti-dazzle function • TCS: Traction Control System • Three-point, height adjustable and tensioning inertia reel seat belts |
|--|--|--|

Model specific features.

Caddy Sportline specific.

- | | |
|---|---|
| <ul style="list-style-type: none"> • Full height bulkhead - solid lower and plastic mesh upper | <ul style="list-style-type: none"> • Side sliding door on left |
|---|---|

Caddy Maxi Sportline specific.

- | | |
|--|--|
| <ul style="list-style-type: none"> • Full height bulkhead - solid | <ul style="list-style-type: none"> • Side sliding doors on left and right |
|--|--|

¹ Items fitted in UK by a Volkswagen approved supplier, please refer to page 105 for details.

The Volkswagen Caddy Maxi kombi.



Load floor showing accommodation of euro-pallet.

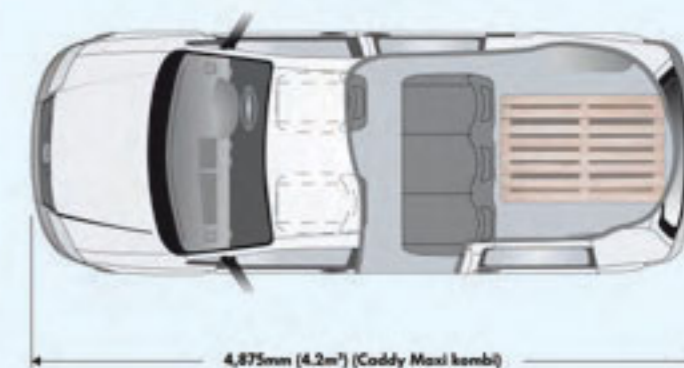

Whether you want room for passengers or loadspace, or a combination of both, the Caddy Maxi kombi provides the ideal solution. Its flexible design allows you to seat up to five people – ideal if you need to carry crew to site each day – and if you have to carry additional equipment, you can create extra load space easily and quickly by simply folding the rear seats forward. This increases the already generous 1.6m³ loadspace to a vast 3.9m³, ready to accommodate whatever extra equipment you need to carry.

Access to the Caddy Maxi kombi's rear seating couldn't be simpler, with two 700mm wide side-sliding doors enabling passengers to get in and out with the greatest of ease. It's easy to get your load in and out, too, as a large tailgate provides entry to the rear of the van. A window in the middle panel enables passengers in the second row of seats to see outside, and the back panel is metal to protect your load from prying eyes. Lashing rings are also provided, to ensure your load is kept safe and secure during transit.

A choice of two powerful and economical 'Pumpe Duse' (PD) diesel engines deliver a combination of top performance and exceptional frugality, enabling you to cruise effortlessly on the motorway or nip around town, while the optional Direct Shift Gearbox (DSG) lets you change gear much faster than a standard automatic gearbox, ideal for city work. With a host of features, such as a CD player, fitted as standard, the Caddy Maxi kombi is fully equipped to ensure your total comfort and convenience.

The following pages provide more detail, but here's an overview of what the Caddy Maxi kombi has to offer:

- Seating for up to five, including the driver
- Load volume up to 3.9m³
- Payload up to 671kg
- 700mm wide sliding doors to left and right
- Large tailgate
- Choice of two diesel engines
- ABS, EBC, EBD and TCS*

* Please refer to the glossary on page 106 of this brochure.

Caddy Maxi kombi standard specifications.

Body.		
<ul style="list-style-type: none"> 60 litre lockable fuel tank Black wheel centre caps Externally adjustable exterior mirrors: <ul style="list-style-type: none"> Aspherical on driver's side Convex on passenger's side 	<ul style="list-style-type: none"> Front and rear towing eyes Grey bumpers Heat reflective glass in side sliding doors Jack and tool kit with steel spare wheel Partially galvanised all-steel body 	<ul style="list-style-type: none"> Roof load rack preparation Side sliding door on left and right Tailgate with heated rear window and wash/wipe
Interior.		
Cab area: <ul style="list-style-type: none"> 2 folding and pivoting sun visors Rubber floor covering Driver's seat with height, reach and rake adjustment 'Fifty-five' art grey fabric seat covers Grab handles on roof frame Interior light in headliner 	<ul style="list-style-type: none"> Passenger seat with reach and rake adjustment Storage: <ul style="list-style-type: none"> 2 storage trays in dash panel 4 drinks holders and storage compartment in centre console Open glove compartment Overhead storage 	Rear: <ul style="list-style-type: none"> 2 door-activated interior lights 3 seat bench Rubber floor covering Interior roof trim in hardboard
Functional.		
<ul style="list-style-type: none"> 12V socket Digital clock Dimmable dashboard illumination Manually controlled heating system with dust and pollen filter and air recirculation 	<ul style="list-style-type: none"> Radio/single CD player, MP3 compatible with 2 wideband speakers Remote central locking with deadlocks, internal locking switch and 1 remote key 	<ul style="list-style-type: none"> Rev counter Warning buzzer for lights left on Windscreen wiper with variable intermittent delay and wash/wiper system
Technical.		
<ul style="list-style-type: none"> Front and rear axle: <ul style="list-style-type: none"> Anti-roll bars, front and rear Front McPherson strut suspension Rear rigid axle with single layer leaf springs Telescopic shock absorbers 	<ul style="list-style-type: none"> Hydraulic brake system with disc brakes and ABS: Anti-lock Braking System Power steering - hydraulic (on 104PS engine) Power steering - electro-mechanical speed dependent - servotronic (on 140PS engine) Steel wheels: 6.0J x 15 (on 104PS engine) 	<ul style="list-style-type: none"> Steel wheels: 6.0J x 16 (on 140PS engine) Tyres: 195/65 R15 (on 104PS engine) Tyres: 205/55 R16 (on 140PS engine)
Safety and security.		
<ul style="list-style-type: none"> 3rd brake light ABS: Anti-lock Braking System Breaksafe steering wheel lock Driver and front passenger airbags EBC: Engine Braking Control EBD: Electronic Brakeforce Distribution 	<ul style="list-style-type: none"> Electronic Immobiliser 'Transponder' Halogen main headlights with range control Height adjustable head restraints Height adjustable seat belts for cab seats Height and rake adjustable safety steering column 	<ul style="list-style-type: none"> Rear fog lights Rear-view mirror with anti-dazzle function TCS: Traction Control System Three-point tensioning inertia reel seat belts

Caddy Maxi kombi recommended retail prices.

Model			Manufacturer's RRP			Ins. group**			
			Basic retail excluding VAT £ †	VAT £ †	Total retail including VAT £ †		Total retail including OTR* excluding VAT £ †	Total retail including OTR* including VAT £ †	
Caddy Maxi kombi.									
C20	104PS TDI PD	1.9 l	2KJK42	13,900.00	2,432.50	16,332.50	14,710.00	17,242.25	4E-T2
	104PS TDI PD DSG DPF	1.9 l	2KJK43	15,300.00	2,677.50	17,977.50	16,110.00	18,887.25	4E-T2
	140PS TDI PD DPF	2.0 l	2KJK64	15,700.00	2,747.50	18,447.50	16,510.00	19,357.25	4E-T2

*OTR (on the road) package for Caddy Maxi kombi includes the following:

Delivery to retailer	£550.00
Number plates	£20.00
VAT	£99.75
Road fund licence	£185.00
First registration fee	£55.00
Total	£909.75

† Calculated at 17.5% on all products.

** Insurance group: As advised by the Association of British Insurers (ABI). Please see www.thatcham.org/abigrouprating for more information.



Lashing rings.



Radio/CD player.



Storage in driver and front passenger door.

Caddy Maxi kombi factory options.

	Caddy Maxi kombi	Manufacturer's RRP		
		Basic retail excluding VAT £ †	VAT £ †	Total retail including VAT £ †
Paint options.				
Metallic paint	•	315.00	55.13	370.13
Pearl paint	•	330.00	57.75	387.75
Black paint - 9000	•	280.00	49.00	329.00
Danish blue paint - 9506	•	105.00	18.38	123.38
Friesen green paint - 9644	•	105.00	18.38	123.38
Factory fitted options.				
Alloy wheels - 15" , 4 with steel spare (not 140PS)	•	390.00	68.25	458.25
Alloy wheels - 16" , 4 with steel spare (140PS only)	•	670.00	117.25	787.25
Appearance pack - body coloured bumpers and wing mirrors (only with electric pack) ¹	•	200.00	35.00	235.00
AUX-IN socket - for connection to external multimedia source (not with satellite navigation)	•	25.00	4.38	29.38
Carpet floor covering in cab and passenger compartment - in lieu of rubber	•	0.00	0.00	0.00
CD changer - in centre console	•	300.00	52.50	352.50
Cruise control	•	185.00	32.38	217.38
ESP plus ²	•	260.00	45.50	305.50
Fog lights - front (included in visibility pack A)	•	110.00	19.25	129.25
Key - 2nd , for remote locking (included with alarm packs A and B)	•	10.00	1.75	11.75
Parking sensors - rear	•	230.00	40.25	270.25
Privacy glass - rear	•	130.00	22.75	152.75
Satellite navigation A - colour touch screen (CD), includes trip computer ³ (not with AUX-IN socket)	•	800.00	140.00	940.00
Steering wheel - leather trimmed, multi-function with trip computer	•	290.00	50.75	340.75
Towbar - fixed ball with 13 pin socket ⁴	•	325.00	56.88	381.88
Trip computer (included with satellite navigation and steering wheel - leather)	•	120.00	21.00	141.00
Tyres - all weather	•	110.00	19.25	129.25

Options packs.

Alarm pack A - perimeter with back-up horn (includes 2nd key for remote locking)	•	140.00	24.50	164.50
Alarm pack B - with interior (cab only) and tow away protection (includes 2nd key for remote locking)	•	170.00	29.75	199.75
Cab comfort pack ⁵	•	200.00	35.00	235.00
Electric pack - electric windows and electrically heated and adjustable mirrors	•	280.00	49.00	329.00
Smoking pack - ashtray and cigarette lighter	•	15.00	2.63	17.63



15" alloy wheels.



16" alloy wheels.



Fog lights.

	Caddy Maxi kombi	Manufacturer's RRP		
		Basic retail excluding VAT £ †	VAT £ †	Total retail including VAT £ †
Options packs (continued).				
Visibility pack A - front fog lights, headlight washers, heated washer jets and washer fluid level indicator	•	290.00	50.75	340.75
Visibility pack B - rain sensor, automatic dimming rear view mirror and 'coming home' function	•	105.00	18.38	123.38
Airbag packs.				
Airbag pack C - side airbags	•	160.00	28.00	188.00
Airbag pack D - thorax head airbags	•	300.00	52.50	352.50
Door packs.				
Rear door pack C - rear wing door with heated rear window and wash/wipe	•	90.00	15.75	105.75
Heating and ventilation.				
Air conditioning - 'Climatic', semi-automatic	•	780.00	136.50	916.50
Seat packs.				
Seats - leatherette upholstery	•	25.00	4.38	29.38
Seat pack A - heated driver and front passenger seats	•	205.00	35.88	240.88
Window packs.				
Window pack A - sliding windows in side sliding doors	•	320.00	56.00	376.00

- Options.
- Not available.

† Calculated at 17.5% on all products.

¹ **Appearance pack:** Restricted colours, please confirm availability with your Volkswagen Van Centre.

² **ESP plus:** Includes Driver Steering Response (DSR) and trailer stabilisation function.

³ **Satellite navigation:** Replaces radio, includes RDS radio function with single CD (audio CDs cannot be played when using navigation function).

⁴ **Towbars:** An adaptor is available from Van Centres, to allow connection to twin 7 pin sockets.

⁵ **Cab comfort pack:** Height adjustable front seats, drawers under front seats, vanity mirrors and dash tray with cover.



Visibility pack B.



'Climatic' air conditioning.



Towbar.

Options subject to availability.

Caddy Maxi kombi dimensions and weights.

Caddy Maxi kombi.

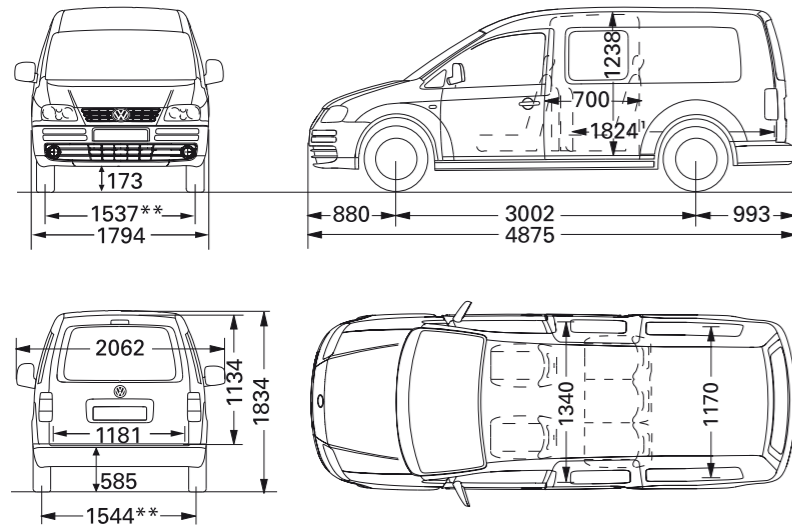

Wheelbase	3,002
Passenger compartment	
length	1,824 ¹
width	1,340
height	1,238
volume ²	1.6/3.9m ³
Lateral sliding door	
width	700
height	1,108
Rear tailgate	
width	1,181
height	1,134
Turning circle (wall to wall)	12.2m

¹ With 1st row of seats double folded forwards.
² Behind 1st row of seats/with 1st row of seats double folded forwards.
 ** -6mm, depending on wheel size.
 Dimensions in mm unless otherwise indicated.

The height measurements listed here can differ by approx. ± 50mm depending on equipment.

Model	Gross vehicle weight kg	Engine	Axle load limit front / rear kg	Trailer weight braked / unbraked* kg	Gross train weight kg	Unladen** weight kg	Payload** kg	
C20	2,280	104PS TDI PD	1.9 l	1,180 / 1,230	1,500 / 750	3,500	1,660	620
	2,280	104PS TDI PD DSG	1.9 l	1,200 / 1,230	1,500 / 750	3,500	1,696	584
	2,360	140PS TDI PD	2.0 l	1,200 / 1,250	1,500 / 750	3,500	1,689	671

Roof load limit: Caddy Maxi kombi 100kg.

Trailer nose weight limit: Caddy Maxi kombi 80kg.

* For 12% gradient.

** Unladen weight and payload includes approximately 90% fuel load and 75kg for driver.

Payload = gross vehicle weight - unladen weight.

Weights are for vehicles with standard specification. The addition of factory options or Volkswagen Van Centre fitted accessories may affect unladen weight and payload.

Caddy Maxi kombi fuel consumption, performance and CO₂ emissions.

Engine	Urban mpg (l/100km)	Extra urban mpg (l/100km)	Combined mpg (l/100km)	CO ₂ emissions (g/km)	Acceleration 0-62 mph	Top speed (where the law permits) mph
Caddy Maxi kombi.						
104PS TDI PD	1.9 l	36.7 (7.7)	52.3 (5.4)	45.6 (6.2)	13.5	102
104PS TDI PD DSG DPF	1.9 l	34.0 (8.3)	47.1 (6.0)	40.9 (6.9)	13.5	103
140PS TDI PD DPF	2.0 l	36.2 (7.8)	51.4 (5.5)	44.8 (6.3)	11.1	116

Fuel consumption figures for Caddy Maxi kombi with 5 seats and a 60 litre fuel tank capacity.

The performance figures listed above apply to vehicles with 5-speed or 6-speed manual gearbox and DSG semi-automatic gearbox, without optional extras.

Caddy Maxi kombi engine specifications.

	104PS TDI PD	140PS TDI PD
Engine type	Transverse, water cooled in line, variable geometry turbocharger with intercooler.	
Mixture preparation/injection method	Unit injector pump direct injection.	
EU exhaust emission standard	4	
No. of cylinders	4	
Cubic capacity, cm ³	1,896	1,968
Output, PS at rpm	104 at 4,000	140 at 4,000
Torque, max. Nm/rpm	250/1,900	320/1,800 – 2,500
Diesel Particulate Filter (DPF)	- ¹	•
5-speed manual gearbox	•	-
6-speed manual gearbox	-	•
6-speed semi-automatic	-	•
DSG gearbox	• ¹	-
Front wheel drive	•	•

Electrics.

Alternator (all variants)	110A
Battery	61Ah (330A)

- Available.
- Not available.

¹ The 104PS TDI PD diesel engine with 6-speed DSG semi-automatic gearbox is equipped with a Diesel Particulate Filter (DPF) as standard.

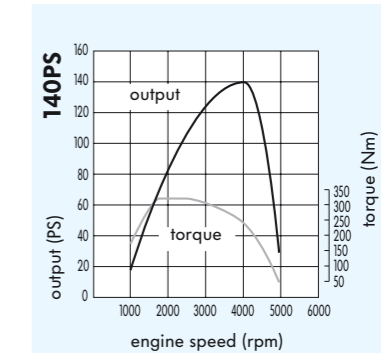
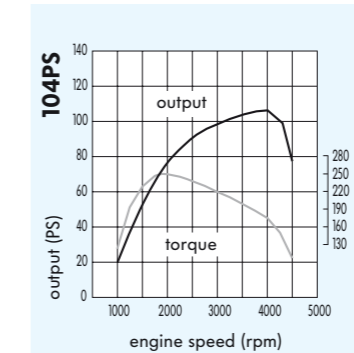

Direct Shift Gearbox.

The award winning and highly acclaimed Direct Shift Gearbox (DSG) is unique to the commercial vehicle market and operates with two automatic clutches – while one is engaged, the other is ready and to accept the next gear. This twin clutch technology means you can change gear much faster than with a standard automatic gearbox – actually in less than four hundredths of a second.

This means that for stop-start round city work the DSG comes into its own, making life much easier for the driver. Of course you can still change gear manually if you prefer!



The new Volkswagen Transporter panel van.



Load floor showing accommodation of euro-pallets.

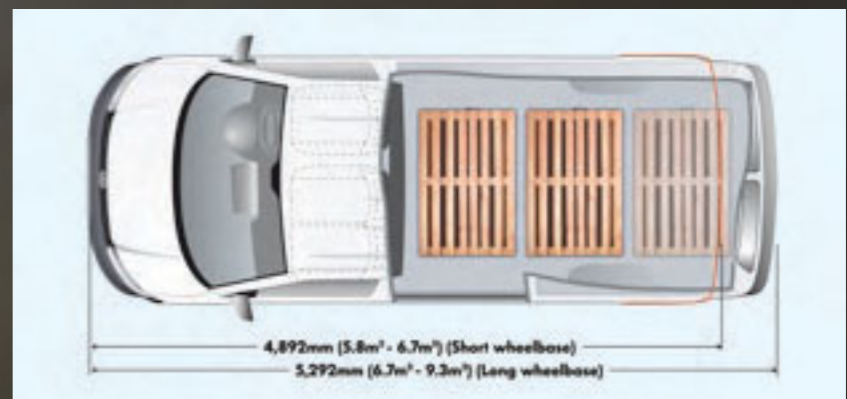

The world-renowned Transporter has always enjoyed a solid reputation for its versatility, features and sheer dependability. Now, safer, smarter and more efficient than ever before, the new generation Transporter panel van offers new levels of comfort, refinement and performance.

For a start, new TDI common rail diesel engines offer significantly improved fuel economy and greatly reduced CO₂ emissions. There's also the option of a 7-speed DSG Direct Shift Gearbox, offering greater driving comfort, and 4MOTION® four-wheel drive, capable of taking rough, wet or snowy terrain in its stride, and enabling you to reach more inaccessible sites easily and safely.

The restyled exterior gives the new Transporter a timeless, elegant appeal, and inside the new three-spoke steering wheel and re-worked dash and instrument cluster greatly enhance the driving experience. Safety features now include ESP with hill hold assist, driver and passenger airbags and hazard light activation during emergency braking all as standard. Comfortable, safe and highly intelligent, the new Transporter is now quite simply more capable and more refined than ever before.

Main features of new Transporter panel van:

- Outstanding fuel economy and greatly reduced CO₂ emissions
- Optional award-winning DSG gearbox and 4MOTION® four-wheel drive
- Restyled exterior and interior
- High level of standard specification, with focus on driver comfort
- Extensive choice of optional equipment

- Short or long wheelbase
- Low, medium or high roof
- Load volumes from 5.8m³ to 9.3m³
- Payloads from 749kg up to 1,333kg
- Twin rear doors as standard or optional tailgate
- Dual passenger seat with folding backrest for additional load length

New Transporter panel van standard specifications.

Body.

- 80 litre lockable fuel tank
- Black wheel centre caps
- Externally adjustable exterior mirrors:
 - Convex on passenger's side
 - Aspherical on driver's side
- Front and rear towing eyes
- Galvanised full steel body
- Grey bumpers
- Heat reflective glass
- Tyre repair kit
- Unglazed rear wing doors

Interior.

- | | | |
|---|---|---|
| <p>Cab area:</p> <ul style="list-style-type: none"> • 2 folding and pivoted sun visors • Dash mounted gear lever • Driver's seat with height, lumbar, reach and rake adjustment • Dual passenger seat with storage box and folding seat backrest (fixed backrest with optional bulkheads) • 'Place' fabric seat covers • Interior light • Rubber floor covering | <p>Storage:</p> <ul style="list-style-type: none"> - 2 storage compartments in dash panel - 2 storage compartments in driver's door - 2 storage compartments in passenger door - Drinks holder - Lockable glove compartment - Open storage compartment in dash panel including mobile phone holder - Overhead storage - Storage net on lower dash passenger side | <p>Rear:</p> <ul style="list-style-type: none"> • 2 door-activated interior lights (3 with optional high roof) • Half height load side lining in hardboard • Interior entry step • Interior roof trim in painted hardboard (low roof only) • Load lashing rings (SWB: 6, LWB: 8) • Rear door interior release lever • Sheet steel flooring • Side sliding door on left |
|---|---|---|

Functional.

- | | | |
|---|--|---|
| <ul style="list-style-type: none"> • 12V socket • Digital clock • Manually controlled heating system with dust and pollen filter and air recirculation | <ul style="list-style-type: none"> • RCD 210 radio/single CD player with 2 speakers • Remote central locking with deadlocks (1 fixed and 2 folding remote keys) • Rev counter | <ul style="list-style-type: none"> • Up and downshift gear indicator • Warning buzzer for lights left on • Windscreen wiper with variable intermittent delay and wash/wiper system |
|---|--|---|

Technical.

- | | | |
|---|---|--|
| <ul style="list-style-type: none"> • Front and rear axle: <ul style="list-style-type: none"> - Anti-roll bars, front and rear (T26 front only) - Front McPherson strut suspension - Independent suspension - Rear miniblock springs - Telescopic shock absorbers | <ul style="list-style-type: none"> • Hydraulic brake system with ventilated disc brakes • Power steering • Rear differential lock (4MOTION® only) • Steel wheels: 6.5J x 16 (on 84, 102 and 140PS versions)
7J x 17 (on 180PS versions) | <ul style="list-style-type: none"> • Tyres: 205/65 R16 (on 84, 102 and 140PS versions)
235/55 R17 (on 180PS versions) |
|---|---|--|

Safety and security.

- | | | |
|--|--|--|
| <ul style="list-style-type: none"> • 3rd brake light • ABS: Anti-lock Braking System • Automatic hazard lights activation under emergency braking • Breaksafe steering wheel lock • Driver and passenger (with deactivation) airbag • Driver seatbelt warning signal • EBC: Engine Braking Control (not 4MOTION®) | <ul style="list-style-type: none"> • EBD: Electronic Brakeforce Distribution • Electronic immobiliser 'Transponder' • ESP: Electronic Stabilisation Programme • Halogen main headlights with range control and daytime running function • Height adjustable head restraints • Height adjustable, tensioning seat belts for all outer cab seats | <ul style="list-style-type: none"> • Height and rake adjustable safety steering column • Hill hold control • Rear fog light • TCS: Traction Control System (not 4MOTION®) • Three-point inertia reel seat belts for all seats |
|--|--|--|



RCD 210 Radio/CD player.



Rear wing doors.



Dash mounted gear lever.



Driver and passenger airbags.



Side sliding door on left.



3 spoke steering wheel.

New Transporter panel van recommended retail prices.

Model	Manufacturer's RRP					Ins. group**		
	Basic retail excluding VAT £ †	VAT £ †	Total retail including VAT £ †	Total retail including OTR* excluding VAT £ † including VAT £ †				
Panel van short wheelbase.								
T26	84PS TDI	7EAA12	15,700.00	2,747.50	18,447.50	16,450.00	19,297.25	5E
T28	84PS TDI	7EAB12	16,050.00	2,808.75	18,858.75	16,800.00	19,708.50	5E
	102PS TDI	7EAB22	16,800.00	2,940.00	19,740.00	17,550.00	20,589.75	6E
	140PS TDI	7EAB31	18,300.00	3,202.50	21,502.50	19,050.00	22,352.25	6E
	180PS BITDI	7EAB41	19,900.00	3,482.50	23,382.50	20,650.00	24,232.25	6E
T30	84PS TDI	7EAC12	16,400.00	2,870.00	19,270.00	17,150.00	20,119.75	6E
	102PS TDI	7EAC22	17,150.00	3,001.25	20,151.25	17,900.00	21,001.00	6E
	140PS TDI	7EAC31	18,650.00	3,263.75	21,913.75	19,400.00	22,763.50	6E
	140PS TDI DSG	7EAC37	20,050.00	3,508.75	23,558.75	20,800.00	24,408.50	7E
	140PS TDI 4MOTION®	7EAC35	20,850.00	3,648.75	24,498.75	21,600.00	25,348.50	7E
	180PS BITDI	7EAC41	20,250.00	3,543.75	23,793.75	21,000.00	24,643.50	7E
180PS BITDI DSG	7EAC49	23,850.00	4,173.75	28,023.75	24,600.00	28,873.50	7E	
T32	102PS TDI	7EAD22	17,500.00	3,062.50	20,562.50	18,250.00	21,412.25	7E
	140PS TDI	7EAD31	19,000.00	3,325.00	22,325.00	19,750.00	23,174.75	7E
Panel van long wheelbase.								
T30	84PS TDI	7EHC12	16,890.00	2,955.75	19,845.75	17,640.00	20,695.50	6E
	102PS TDI	7EHC22	17,640.00	3,087.00	20,727.00	18,390.00	21,576.75	6E
	140PS TDI	7EHC31	19,140.00	3,349.50	22,489.50	19,890.00	23,339.25	6E
	140PS TDI DSG	7EHC37	20,540.00	3,594.50	24,134.50	21,290.00	24,984.25	6E
	140PS TDI 4MOTION®	7EHC35	21,340.00	3,734.50	25,074.50	22,090.00	25,924.25	6E
	180PS BITDI	7EHC41	20,740.00	3,629.50	24,369.50	21,490.00	25,219.25	6E
	180PS BITDI DSG	7EHC49	24,340.00	4,259.50	28,599.50	25,090.00	29,449.25	7E
	180PS BITDI 4MOTION®†							
T32	102PS TDI	7EHD22	17,990.00	3,148.25	21,138.25	18,740.00	21,988.00	7E
	140PS TDI	7EHD31	19,490.00	3,410.75	22,900.75	20,240.00	23,750.50	7E

† Calculated at 17.5% on all products.

‡ Please contact your nearest Van Centre for full details of availability.

** Insurance group: As advised by the Association of British Insurers (ABI). Please see www.thatcham.org/abigrouprating for more information.

*OTR (on the road) package for panel vans includes the following:
 Delivery to retailer £550.00
 Number plates £20.00
 VAT £99.75
 Road fund licence £125.00
 First registration fee £55.00
Total £849.75

New Transporter panel van factory options.

	SWB				LWB		Manufacturer's RRP		
	T26	T28	T30	T32	T30	T32	Basic retail excluding VAT £ †	VAT £ †	Total retail including VAT £ †
Paint options.									
Metallic and pearl paint	•	•	•	•	•	•	475.00	83.13	558.13
Black paint - 9000	•	•	•	•	•	•	280.00	49.00	329.00
Grey white paint - 9904	•	•	•	•	•	•	100.00	17.50	117.50
Danish blue paint - 9506	•	•	•	•	•	•	100.00	17.50	117.50
Stone blue paint - 9544	•	•	•	•	•	•	100.00	17.50	117.50
Factory fitted options.									
Alloy wheels - 'Cartagena' 16" with 215/65 R16 tyres, (not with 180PS or T32 models)	•	•	•	-	•	-	585.00	102.38	687.38
Alloy wheels - 'Miyato' 16" with 215/65 R16 tyres, (not with 180PS or T32 models)	•	•	•	-	•	-	490.00	85.75	575.75
Alloy wheels - 'Thunder' 17" with 235/55 R17 tyres, (not with tyres - all weather, 180PS or T32 models)	•	•	•	-	•	-	930.00	162.75	1,092.75
Alloy wheels - 'Thunder' 17" with 235/55 R17 tyres, (180PS only, not with tyres - all weather or T32 models)	-	•	•	-	•	-	360.00	63.00	423.00
Alloy wheels - 'Canberra' 18" with 255/45 R18 tyres (140PS engines only, not with tyres - all weather or T32 models)	-	•	•	-	•	-	1,870.00	327.25	2,197.25
Alloy wheels - 'Canberra' 18" with 255/45 R18 tyres (180PS engines only, not with tyres - all weather or T32 models)	-	•	•	-	•	-	1,300.00	227.50	1,527.50
Alternator - uprated	•	•	•	•	•	•	65.00	11.38	76.38
Alternator/battery - uprated (not with alarm packs)	•	•	•	•	•	•	95.00	16.63	111.63
Battery - uprated (not with alarm packs)	•	•	•	•	•	•	35.00	6.13	41.13
Battery - second¹	•	•	•	•	•	•	180.00	31.50	211.50
CD changer - six disc (only with seat pack B)	•	•	•	•	•	•	265.00	46.38	311.38
Cruise control	•	•	•	•	•	•	165.00	28.88	193.88
Fog lights - front and cornering lights	•	•	•	•	•	•	255.00	44.63	299.63
Load floor cover - rubber, with step light	•	•	•	•	-	-	120.00	21.00	141.00
					•	•	140.00	24.50	164.50
Load lashing rails -	•	•	•	•	-	-	315.00	55.13	370.13
	-	-	-	-	•	•	360.00	63.00	423.00
Load side lining - full-height hardboard²	•	•	•	•	-	-	205.00	35.88	240.88
	-	-	-	-	•	•	235.00	41.30	276.13

• Options.
 - Not available.

¹ **Battery - second:** 72Ah with dual passenger seat, 80Ah with single passenger seat.
² **Load side lining:** Side panels covered to roof, tailgate/rear doors only half-height.

† Calculated at 17.5% on all products.



16" 'Miyato' alloy wheel.



17" 'Thunder' alloy wheel.



Cruise control.

Options subject to availability.

New Transporter panel van factory options. (continued)

	SWB				LWB		Manufacturer's RRP		
	T26	T28	T30	T32	T30	T32	Basic retail	VAT £ †	Total retail
							excluding		including
Factory fitted options. (continued)									
Mud flaps - front and rear	•	•	•	•	•	•	90.00	15.75	105.75
Parking sensors - rear	•	•	•	•	•	•	190.00	33.25	223.25
Roof load rack preparation (not with medium or high roof packs)	•	•	•	•	•	•	70.00	12.25	82.25
Smoking pack - ashtray, cigarette lighter and cup holder	•	•	•	•	•	•	15.00	2.63	17.63
Spare wheel - steel	•	•	•	•	•	•	0.00	0.00	0.00
Sunroof - glass, electric, front (not with roof ventilation/extraction - rear compartment, medium or high roof packs, bulkhead packs or side door pack A)	•	•	•	•	•	•	465.00	81.38	546.38
Tachograph - digital, includes console on dash	•	•	•	•	•	•	440.00	77.00	517.00
Towbar - fixed ball with 13 pin socket ³	•	•	•	•	•	•	360.00	63.00	423.00
Towbar - removable ball with 13 pin socket ³	•	•	•	•	•	•	450.00	78.75	528.75
Trip computer (included with satellite navigation and leather pack B)	•	•	•	•	•	•	225.00	39.38	264.38
Tyre pressure warning light	•	•	•	•	•	•	50.00	8.75	58.75
Tyres - all weather, 215/65 R16 (not with alloy wheels - 'Thunder' or 'Canberra' or 180PS engines)	•	•	•	•	•	•	195.00	34.13	229.13
Tyres - all weather, 215/65 R16 (180PS engines only, not with alloy wheels - 'Thunder' or 'Canberra')	-	•	•	-	•	-	90.00	15.75	105.75
Options packs.									
Alarm pack A - perimeter with back-up horn (includes 2nd remote key) ⁴	•	•	•	•	•	•	130.00	22.75	152.75
Alarm pack B - with interior (cab only) and tow away protection (includes 2nd remote key) (not with medium or high roof packs or roof ventilation/extraction) ⁵	•	•	•	•	•	•	155.00	27.13	182.13
Appearance pack - electric windows, electrically adjustable, heated, folding and body coloured mirrors and body coloured bumpers (not with electric pack A or B or 'S'/'SE' pack) ⁶	•	•	•	•	•	•	625.00	109.38	734.38
Cab comfort pack ⁷	•	•	•	•	•	•	265.00	46.38	311.38
Electric pack A - electric windows, electrically heated and adjustable mirrors and internal central locking control (not with appearance pack)	•	•	•	•	•	•	330.00	57.75	387.75
Electric pack B - electric windows, electrically heated, adjustable and folding mirrors and internal central locking control (not with appearance pack)	•	•	•	•	•	•	415.00	72.63	487.63
Electric pack C - internal central locking control (only with appearance pack)	•	•	•	•	•	•	30.00	5.25	35.25
Lane change assist - includes visibility pack B, cruise control and multi-function display (SWB, only with rear door pack A or B)	•	•	•	•	-	-	1,300.00	227.50	1,527.50



Lane change assist.



Airbags.



Fog lights with corning light function.



Full-height load side lining.



Roof load rack preparation.



Satellite navigation B.

	SWB				LWB		Manufacturer's RRP		
	T26	T28	T30	T32	T30	T32	Basic retail	VAT £ †	Total retail
							excluding		including
Options packs. (continued)									
Leather pack A - leather steering wheel, gearknob and gaiter	•	•	•	•	•	•	120.00	21.00	141.00
Leather pack B - multi-function leather steering wheel, gearknob and gaiter, includes trip computer	•	•	•	•	•	•	460.00	80.50	540.50
S pack - alarm pack A, bulkhead pack A, electric pack A ⁸	•	•	•	•	•	•	520.00	91.00	611.00
SE pack - air conditioning pack A, alarm pack A, bulkhead pack A, electric pack A, seat pack A ⁸	•	•	•	•	•	•	1,180.00	206.50	1,386.50
Satellite navigation A - CD colour screen, includes trip computer and radio upgrade RCD 310, MP3 compatible with AUX-IN and 4 speakers (not with digital radio) ^{4,9}	•	•	•	•	•	•	600.00	105.00	705.00
Satellite navigation B - DVD colour touch screen, includes trip computer, AUX-IN and 4 speakers (not with digital radio) ^{4,9}	•	•	•	•	•	•	1,770.00	309.75	2,079.75
Visibility pack A - headlamp washers, fluid level indicator and heated washer jets	•	•	•	•	•	•	170.00	29.75	199.75
Visibility pack B - rain sensor and automatic dimming rear view mirror	•	•	•	•	•	•	90.00	15.75	105.75
Airbag packs.									
Airbags - side and front curtain airbags (only with seat pack B)	•	•	•	•	•	•	240.00	42.00	282.00
Audio options.									
DAB - digital radio reception (only with radio upgrade RCD 310, not with satellite navigation)	•	•	•	•	•	•	160.00	28.00	188.00
Radio upgrade - RCD 310, MP3 compatible with AUX-IN and 4 speakers (standard with satellite navigation)	•	•	•	•	•	•	75.00	13.13	88.13

- Options.
- Not available.

† Calculated at 17.5% on all products.

³ **Towbars:** An adaptor is available from Van Centres, to allow connection to twin 7 pin sockets. Only one front towing eye with towbars.

⁴ Battery updated to 80Ah on 84/102PS engines, 95Ah on 140/180PS engines.

⁵ **Alarm pack B:** Battery updated to 95Ah.

⁶ Restricted colours, check with your Van Centre.

⁷ **Cab comfort pack:** 'Tasamo' fabric upholstery, carpet in cab, storage compartments in outer side of driver and passenger seats, vanity mirrors, sunglasses holder, interior light delay, 2 reading lights, instrument dimmer, grab handles on 'A' pillars, two tone horn and additional noise suppression measures.

⁸ It is not possible to select alternative equipment to that specified.

⁹ **Satellite navigation A and B:** Replaces radio/in-dash CD player, includes RDS radio function with single CD and CD changer control, where fitted (audio CDs cannot be played when using navigation disc).

Options subject to availability.

New Transporter panel van factory options. (continued)

	SWB				LWB		Manufacturer's RRP		
	T26	T28	T30	T32	T30	T32	Basic retail	VAT £ †	Total retail
							excluding		including
Bulkhead packs.									
Bulkhead pack A - high, without window, includes 2 additional 'C' pillar load lashing rings (not with sunroof) ¹¹	•	•	•	•	•	•	160.00	28.00	188.00
Bulkhead pack B - high, with window, includes 2 additional 'C' pillar load lashing rings (not with sunroof) ^{10,11}	•	•	•	•	•	•	190.00	33.25	223.25
Bulkhead pack C - high, with sliding window, includes 2 additional 'C' pillar load lashing rings (not with sunroof) ^{10,11}	•	•	•	•	•	•	230.00	40.25	270.25
Door packs.									
Rear doors - 250° hinges (not with rear door packs A or B)	-	-	-	-	•	•	250.00	43.75	293.75
Rear door pack A - tailgate with heated rear window and wash/wipe (not with high roof packs) ¹⁰	•	•	•	•	•	•	100.00	17.50	117.50
Rear door pack B - tailgate without window (not with high roof packs)	•	•	•	•	•	•	0.00	0.00	0.00
Rear door pack C - wing doors with heated rear windows and wash/wipe (included with roof packs E and F) ¹⁰	•	•	•	•	•	•	100.00	17.50	117.50
Side door pack A - right only (no left door), manual (not with sunroof)	•	•	•	•	•	•	0.00	0.00	0.00
Side door pack B - left and right, manual (not with high roof packs)	•	•	•	•	•	•	420.00	73.50	493.50
Heating and ventilation.									
Air conditioning pack A - 'Climatic', cab only ¹³	•	•	•	•	•	•	750.00	131.25	881.25
Charcoal canister - for ventilation system	•	•	•	•	•	•	15.00	2.63	17.63
Roof ventilation/extraction - rear compartment (not with alarm pack B or sunroof)	•	•	•	•	•	•	285.00	49.88	334.88
Roof packs.									
Roof pack A - medium, white (not with alarm pack B, roof load rack preparation or sunroof)	-	•	•	-	•	•	420.00	73.50	493.50
Roof pack B - medium, body-coloured (not with alarm pack B, roof load rack preparation or sunroof) ¹⁴	-	•	•	-	•	•	510.00	89.25	599.25
Roof pack C - high, white, includes high rear wing doors without windows (not with alarm pack B, roof load rack preparation, sunroof or side door pack B)	-	-	-	-	•	•	725.00	126.88	851.88

	SWB				LWB		Manufacturer's RRP		
	T26	T28	T30	T32	T30	T32	Basic retail	VAT £ †	Total retail
							excluding		including
Roof packs. (continued)									
Roof pack D - high, body-coloured, includes high rear wing doors without windows (not with alarm pack B, roof load rack preparation, sunroof or side door pack B) ¹⁴	-	-	-	-	•	•	835.00	146.13	981.13
Roof pack E - high, white, includes high rear wing doors with heated rear windows and wash/wipe (not with alarm pack B, roof load rack preparation, sunroof or side door pack B) ¹¹	-	-	-	-	•	•	825.00	144.38	969.38
Roof pack F - high, body-coloured, includes high rear wing doors with heated rear windows and wash/wipe (not with alarm pack B, roof load rack preparation, sunroof or side door pack B) ^{11,14}	-	-	-	-	•	•	935.00	163.63	1,098.63
Seat packs.									
Seats - leatherette upholstery	•	•	•	•	•	•	25.00	4.38	29.38
Seats - robust upholstery	•	•	•	•	•	•	80.00	14.00	94.00
Seat pack A - driver's comfort seat ¹⁵	•	•	•	•	•	•	55.00	9.63	64.63
Seat pack B - driver and single passenger comfort seats ¹⁶	•	•	•	•	•	•	15.00	2.63	17.63
Seat pack C - heated driver and front passenger seats (only with air conditioning) ¹³	•	•	•	•	•	•	220.00	38.50	258.50
Seat pack E plus - dual bench seat with fold down tray in backrest (not with seat pack C)	•	•	•	•	•	•	75.00	13.13	88.13

- Options.
- Not available.

† Calculated at 17.5% on all products.

- ¹⁰ Vehicles with through vision have a rear view mirror with anti-dazzle function.
- ¹¹ **Bulkhead packs:** Dual passenger seat has fixed backrest with optional bulkheads.
- ¹³ **Uprated alternator:** 120A on 84/102PS engines, 150A on 140/180PS engines.
- ¹⁴ **Roof packs:** Please confirm colour availability with your Volkswagen Van Centre.
- ¹⁵ **Comfort seat:** Adds armrests (height adjustment and lumbar support standard for driver's seat).
- ¹⁶ **Comfort seats:** Adds armrests for both front seats, passenger height adjustment and lumbar support (height adjustment and lumbar support standard for driver's seat).



Parking sensors.



Bulkhead - full-height.



Air conditioning.



Folding door mirrors.



Comfort seats for driver and front passenger.



Roof ventilation/extraction.

Options subject to availability.

New Transporter panel van dimensions and weights.

Panel van short wheelbase low and medium roof.

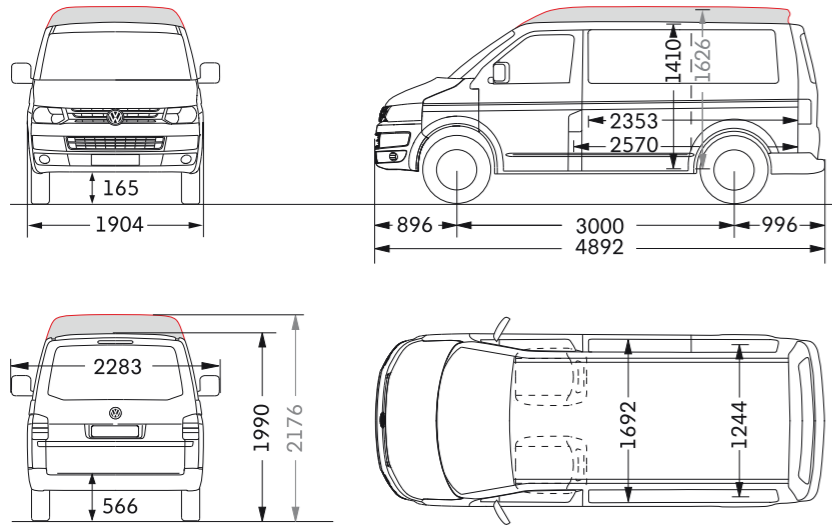

	Roof height	
	low	med
Wheelbase	3,000	3,000
Load compartment length	2,570	2,570
width	1,692	1,692
height	1,410	1,626
area	4.3m ²	4.3m ²
volume	5.8m ³	6.7m ³
Width (between wheel housings)	1,244	1,244
Lateral sliding door width	1,020	1,020
height	1,284	1,284
Rear doors width	1,486	1,486
height	1,305	1,305
Turning circle (wall to wall)	11.9m	11.9m

Indicates optional roof height.

Panel van long wheelbase low, medium and high roof.

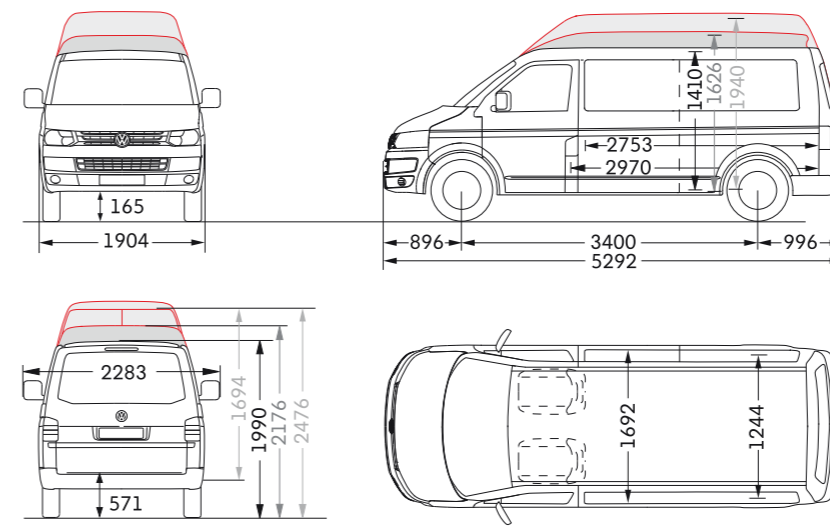

	Roof height		
	low	med	high
Wheelbase	3,400	3,400	3,400
Load compartment length	2,970	2,970	2,970
width	1,692	1,692	1,692
height	1,410	1,626	1,940
area	5.0m ²	5.0m ²	5.0m ²
volume	6.7m ³	7.8m ³	9.3m ³
Width (between wheel housings)	1,244	1,244	1,244
Lateral sliding door width	1,020	1,020	1,020
height	1,284	1,284	1,284
Rear doors width	1,486	1,486	1,486
height	1,305	1,305	1,694
Turning circle (wall to wall)	13.2m	13.2m	13.2m

Indicates optional roof height.

The height measurements listed here may differ by approx ± 50mm depending on equipment fitted. Please note vehicle drawings are not to scale.

Model	Gross vehicle weight kg	Engine	Axle load limit front / rear kg	Trailer weight braked / unbraked* kg	Gross train weight kg	Unladen weight** kg	Payload** kg
T26	2,600	84PS TDI	1,450 / 1,400	2,200 / 750	4,800	1,851	749
T28	2,800	84PS TDI	1,500 / 1,550	2,200 / 750	4,800	1,851	949
		102PS TDI	1,500 / 1,550	2,200 / 750	4,900	1,851	949
		140PS TDI	1,550 / 1,550	2,500 / 750	5,200	1,892	908
		180PS BitDI	1,550 / 1,550	2,500 / 750	5,200	1,939	861
T30	3,000	84PS TDI	1,500 / 1,625	2,200 / 750	4,800	1,851	1,149
		102PS TDI	1,500 / 1,625	2,200 / 750	4,900	1,851	1,149
		140PS TDI	1,550 / 1,625	2,500 / 750	5,200	1,892	1,108
		140PS TDI DSG	1,550 / 1,625	2,500 / 750	5,300	1,904	1,096
		140PS TDI 4MOTION®	1,600 / 1,625	2,500 / 750	5,300	2,014	986
		180PS BitDI	1,550 / 1,625	2,500 / 750	5,200	1,939	1,061
		180PS BitDI 4MOTION®	TBC / TBC	TBC / TBC	TBC	TBC	TBC
T32	3,200	102PS TDI	1,600 / 1,720	2,200 / 750	4,900	1,867	1,333
		140PS TDI	1,650 / 1,720	2,500 / 750	5,200	1,908	1,292

Model	Gross vehicle weight kg	Engine	Axle load limit front / rear kg	Trailer weight braked / unbraked* kg	Gross train weight kg	Unladen weight** kg	Payload** kg
T30	3,000	84PS TDI	1,525 / 1,625	2,200 / 750	4,800	1,912	1,088
		102PS TDI	1,525 / 1,625	2,200 / 750	4,900	1,912	1,088
		140PS TDI	1,575 / 1,625	2,500 / 750	5,200	1,954	1,046
		140PS TDI DSG	1,575 / 1,625	2,500 / 750	5,300	1,966	1,034
		140PS TDI 4MOTION®	1,600 / 1,625	2,500 / 750	5,300	2,075	925
		180PS BitDI	1,575 / 1,625	2,500 / 750	5,200	2,001	999
		180PS BitDI 4MOTION®	TBC / TBC	TBC / TBC	TBC	TBC	TBC
T32	3,200	102PS TDI	1,600 / 1,720	2,200 / 750	4,900	1,928	1,272
		140PS TDI	1,650 / 1,720	2,500 / 750	5,200	1,970	1,230

Trailer nose weight is 100kg.
Roof load limit (not medium or high roof) is: maximum 150kg (with 4 roof bars)
maximum 100kg (with 2 roof bars)

Tailgate load limit (where fitted) is maximum 75kg.
Vehicles with medium or high roof have no provision for roof loads.

* For 12% gradient.
** Unladen weight and payload includes approximately 90% fuel load and 75kg for driver.
Payload = gross vehicle weight - unladen weight.

Weights are for vehicles with standard specification. The addition of factory options or Volkswagen Van Centre fitted accessories may affect unladen weight and payload.

New Transporter panel van engine specification.

	84PS TDI	102PS TDI	140PS TDI	180PS BiTDI
Engine type	Transverse, water cooled in line variable turbine geometry turbocharger with intercooler			Transverse, water cooled in line bi-turbo with intercooler
Mixture preparation/injection method	Common rail direct injection			BiTurbo common rail direct injection
EU exhaust emission standard	5			
No. of cylinders	4			
Cubic capacity, cm ³	1,968			
Output, PS at rpm	84 at 3,500	102 at 3,500	140 at 3,500	180 at 4,000
Torque, max. Nm/rpm	220/1,250-2,500	250/1,500-2,500	340/1,750-2,500	400/1,500-2,000
Diesel particulate filter	•	•	•	•
5-speed manual gearbox	•	•	-	-
6-speed manual gearbox	-	-	•	•
7-speed auto DSG	-	-	•	•
Front wheel drive	•	•	•	•
4MOTION® all wheel drive	-	-	•	•

Electrics.

Alternator	110A
Battery	61Ah (330A)

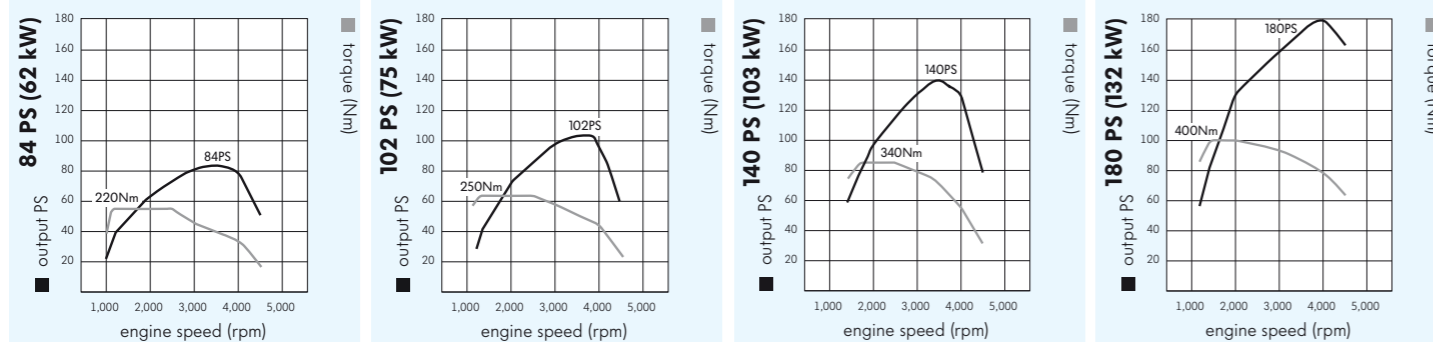

- Available
- Not available

4MOTION® – gets to grips with hard work.

The new Transporter 4MOTION® all wheel drive system is designed to maintain traction in poor surface conditions like rain, snow, mud or gravel. By distributing drive to the wheels with the most grip, 4MOTION® offers stable road-holding and enhanced safety, reacting to the slightest loss of traction in milliseconds.

Available with the 140PS and 180PS engines, 4MOTION® is linked through control units to the vehicle's dynamic sensors, engine management system and gearbox, and is designed to be compatible with ABS. All vehicles fitted with 4MOTION® also have a locking rear differential for additional traction in extreme circumstances.



New Transporter panel van fuel consumption, performance and CO₂ emissions.

Engine	Urban ⁴ mpg (l/100km)	Extra urban ⁴ mpg (l/100km)	Combined ⁴ mpg (l/100km)	Acceleration 0-62 mph	Top speed (where the law permits) mph	CO ₂ emissions (g/km)
Panel van with low roof. (all variants short wheelbase and long wheelbase, T26, T28, T30 and T32*)						
84PS TDI	29.1 (9.7)	44.8 (6.3)	37.7 (7.5)	19.7	91	198
102PS TDI	29.1 (9.7)	44.8 (6.3)	37.7 (7.5)	15.3	98	198
140PS TDI	28.8 (9.8)	43.5 (6.5)	36.7 (7.7)	12.2	107	203
140PS TDI DSG	27.2 (10.4)	40.9 (6.9)	34.4 (8.2)	12.5	107	216
140PS TDI 4MOTION®†	27.2 (10.4)	39.8 (7.1)	34.0 (8.3)	13.5	106	219
180PS BiTDI	28.8 (9.8)	42.2 (6.7)	36.2 (7.8)	9.9	119	205
180PS BiTDI DSG 4MOTION®†	TBC	TBC	TBC	TBC	TBC	TBC

Panel van with medium roof. (T28 and T30 short wheelbase and T30 and T32* long wheelbase)

84PS TDI	29.1 (9.7)	44.8 (6.3)	37.7 (7.5)	19.8	88	198
102PS TDI	29.1 (9.7)	44.8 (6.3)	37.7 (7.5)	15.4	94	198
140PS TDI	28.8 (9.8)	43.5 (6.5)	36.7 (7.7)	12.3	104	203
140PS TDI DSG	27.2 (10.4)	40.9 (6.9)	34.4 (8.2)	12.6	103	216
140PS TDI 4MOTION®†	27.2 (10.4)	39.8 (7.1)	34.0 (8.3)	13.6	102	219
180PS BiTDI	28.8 (9.8)	42.2 (6.7)	36.2 (7.8)	10.0	114	205
180PS BiTDI DSG 4MOTION®†	TBC	TBC	TBC	TBC	TBC	TBC

Panel van with high roof. (T30 and T32* long wheelbase only)

84PS TDI	28.8 (9.8)	40.9 (6.9)	35.8 (7.9)	21.1	91	208
102PS TDI	28.8 (9.8)	40.9 (6.9)	35.8 (7.9)	16.4	98	208
140PS TDI	27.7 (10.2)	40.9 (6.9)	34.9 (8.1)	13.1	107	214
140PS TDI DSG	27.2 (10.4)	38.2 (7.4)	33.2 (8.5)	13.0	107	224
140PS TDI 4MOTION®†	27.2 (10.4)	37.7 (7.5)	32.8 (8.6)	13.6	106	226
180PS BiTDI	28.8 (9.8)	39.8 (7.1)	34.9 (8.1)	10.3	119	214
180PS BiTDI DSG 4MOTION®†	TBC	TBC	TBC	TBC	TBC	TBC

* 84PS not available on T32 models.

† 4MOTION® only available on T30 models.

Please contact your Van Centre for full details of availability.

⁴ With 50% payload and 80 litre fuel tank capacity.

New generation 7-speed Direct Shift Gearbox.

Unique to the commercial vehicle market, this highly acclaimed transmission system is now available for the first time on the new Transporter, making life much easier for the driver.

DSG operates via two automatic clutches: while one is engaged, the other is ready to accept the next gear. This enables changing of gears much faster than a standard automatic gearbox or manual – in less than four hundredths of a second – making it ideal for stop-start city driving.



The new Volkswagen Transporter kombi.



Load floor showing accommodation of euro-pallets.

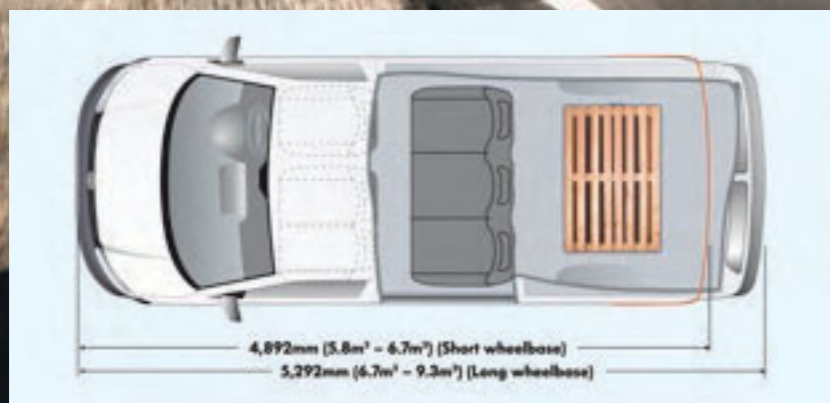

Flexible, versatile and extremely adaptable, that's the new Transporter kombi, offering seating for up to five passengers, plus the driver, with extra room for your load.

Powerful yet frugal, new generation TDI common rail diesel engines deliver impressive fuel economy along with significantly reduced CO₂ emissions, and there's also the option of the new 7-speed DSG Direct Shift Gearbox, offering greater driving comfort. A sliding side door with windows on the left of the kombi provides easy access for passengers, while rear solid panels ensure your load is well concealed.

Restyled inside and out to give a new, more elegant look, the new Transporter kombi provides exceptional levels of comfort, safety and functionality. Standard features include a CD player, driver's seat with height and lumbar adjustment and three-seat bench in the first row, and safety features include driver and passenger airbags, ESP and hazard light warning activation during emergency braking. There's even an optional 'Lane change assist', warning you of any vehicles in your blind spot.

Main features of the new Transporter kombi include:

- Seating for up to 5 passengers, plus the driver, plus your load
- Short or long wheelbase
- Tailgate standard, rear doors optional
- Low, medium or high roof
- Left side sliding door with windows
- Four TDI engines, from 84PS to 180PS
- ESP with hill hold assist as standard
- Restyled exterior and interior
- High level of standard specification
- Great choice of optional equipment

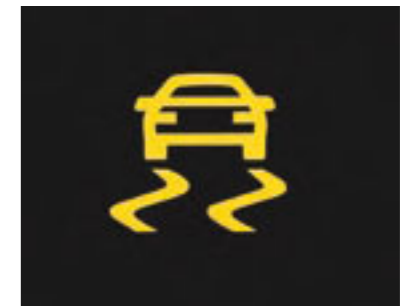

New Transporter kombi standard specifications.

Body.

- 80 litre lockable fuel tank
- Black wheel centre caps
- Externally adjustable exterior mirrors:
 - Convex on passenger's side
 - Aspherical on driver's side
- Front and rear towing eyes
- Galvanised full steel body
- Grey bumpers
- Heat reflective glass
- Tyre repair kit
- Tailgate with heated rear window and wash/wiper system

Interior.

- | | | |
|--|---|--|
| <p>Cab area:</p> <ul style="list-style-type: none"> • 2 folding and pivoted sun visors • Dash mounted gear lever • Driver's seat with height, lumbar, reach and rake adjustment • 'Place' fabric seat covers • Interior light • Rear view mirror with anti-dazzle function • Rubber floor covering • Single passenger seat with reach and rake adjustment | <p>Storage:</p> <ul style="list-style-type: none"> - 2 storage compartments in dash panel - 2 storage compartments in driver's door - 2 storage compartments in passenger door - Drinks holder - Lockable glove compartment - Open storage compartment in dash panel including mobile phone holder - Overhead storage - Storage net on lower dash passenger side | <p>Rear:</p> <ul style="list-style-type: none"> • 2 door-activated interior lights • 3 seat bench in 1st row • Ashtray • Childlocks (not on optional unglazed rear doors) • Interior entry step • Rear door interior release lever • Rubber floor covering • Side sliding door on left • Sliding windows in side door and opposite • Solid rear side panels |
|--|---|--|

Functional.

- | | | |
|---|---|--|
| <ul style="list-style-type: none"> • 12V socket • Digital clock • Manually controlled heating system with dust and pollen filter and air recirculation | <ul style="list-style-type: none"> • RCD 210 radio/single CD player with 2 speakers • Remote central locking with deadlocks (1 fixed and 2 folding remote keys) | <ul style="list-style-type: none"> • Rev counter • Up and downshift gear indicator |
|---|---|--|

Technical.

- | | | |
|---|---|--|
| <p>Front and rear axle:</p> <ul style="list-style-type: none"> - Anti-roll bars, front and rear - Front McPherson strut suspension - Independent suspension - Rear miniblock springs - Telescopic shock absorbers | <ul style="list-style-type: none"> • Hydraulic brake system with ventilated disc brakes • Power steering • Rear differential lock (4MOTION® only) • Steel wheels: 6.5J x 16 (on 84, 102 and 140PS versions)
7J x 17 (on 180PS versions) | <ul style="list-style-type: none"> • Tyres: 205/65 R16 (on 84, 102 and 140PS versions)
235/55 R17 (on 180PS versions) |
|---|---|--|

Safety and security.

- | | | |
|--|---|---|
| <ul style="list-style-type: none"> • 3rd brake light • ABS: Anti-lock Braking System • Automatic hazard lights activation under emergency braking • Breaksafe steering wheel lock • Driver and passenger (with deactivation) airbag • Driver seatbelt warning signal | <ul style="list-style-type: none"> • EBD: Electronic Brakeforce Distribution • Electronic immobiliser 'Transponder' • ESP: Electronic Stabilisation Programme • Halogen main headlights with range control and daytime running function • Height adjustable head restraints • Height adjustable, tensioning seatbelts for outer cab seats | <ul style="list-style-type: none"> • Height and rake adjustable safety steering column • Hill hold control • Rear fog light • Three point inertia reel seatbelts for all seats • TCS: Traction Control System (not 4MOTION®) |
|--|---|---|



RCD 210 Radio/CD player.



Storage in driver and front passenger doors.



Dash mounted gear lever.



Driver and passenger airbags.



Remote control central locking.



3 spoke steering wheel.

New Transporter kombi recommended retail prices.

Model			Manufacturer's RRP			Ins. group**		
			Basic retail excluding VAT £ †	VAT £ †	Total retail including VAT £ †		Total retail including OTR* excluding VAT £ †	Total retail including OTR* including VAT £ †
Kombi short wheelbase.								
T30	84PS TDI	7EBC12	17,880.00	3,129.00	21,009.00	18,630.00	21,858.70	6E
	140PS TDI	7EBC31	20,130.00	3,522.75	23,652.75	20,880.00	24,502.50	8E
T32	102PS TDI	7EBK22	18,980.00	3,321.50	22,301.50	19,730.00	23,151.25	7E
	140PS TDI	7EBK31	20,480.00	3,584.00	24,064.00	21,230.00	24,913.75	7E
	140PS TDI DSG	7EBK37	21,880.00	3,829.00	25,709.00	22,630.00	26,558.75	8E
Kombi long wheelbase.								
T32	102PS TDI	7EJK22	19,470.00	3,407.25	22,877.25	20,220.00	23,727.00	7E
	140PS TDI	7EJK31	20,970.00	3,669.75	24,639.75	21,720.00	25,489.50	7E
	180PS BiTDI	7EJK41	22,570.00	3,949.75	26,519.75	23,320.00	27,369.50	8E

† Calculated at 17.5% on all products.

** Insurance group: As advised by the Association of British Insurers (ABI).

Please see www.thatcham.org/abigrouprating for more information.

*OTR (on the road) package for kombi includes the following:
 Delivery to retailer £550.00
 Number plates £20.00
 VAT £99.75
 Road fund licence £125.00
 First registration fee £55.00
Total £849.75

New Transporter kombi factory options.

	SWB		LWB	Manufacturer's RRP		
	T30	T32	T32	Basic retail excluding VAT £ †	VAT £ †	Total retail including VAT £ †
Paint options.						
Metallic and pearl paint	•	•	•	475.00	83.13	558.13
Black paint - 9000	•	•	•	280.00	49.00	329.00
Grey white paint - 9904	•	•	•	100.00	17.50	117.50
Danish blue paint - 9506	•	•	•	100.00	17.50	117.50
Stone blue paint - 9544	•	•	•	100.00	17.50	117.50
Factory fitted options.						
Alloy wheels - 'Cartagena' 16" with 215/65 R16 tyres, (not T32 models)	•	-	-	585.00	102.38	687.38
Alloy wheels - 'Miyato' 16" with 215/65 R16 tyres, (not T32 models)	•	-	-	490.00	85.75	575.75
Alloy wheels - 'Thunder' 17" with 235/55 R17 tyres (140PS engines only, not with tyres - all weather or T32 models)	•	-	-	930.00	162.75	1,092.75
Alloy wheels - 'Canberra' 18" with 255/45 R18 tyres (140PS engines only, not with tyres - all weather or T32 models)	•	-	-	1,870.00	327.25	2,197.25
Alternator - uprated	•	•	•	65.00	11.38	76.38
Alternator/battery - uprated (not with alarm packs or side door pack C)	•	•	•	95.00	16.63	111.63
Battery - second (included with parking heater A and B) ¹	•	•	•	180.00	31.50	211.50
Battery - uprated (not with alarm packs or side door pack C)	•	•	•	35.00	6.13	41.13
CD changer - six disc (not with seat pack E or E plus)	•	•	•	265.00	46.38	311.38
Cruise control	•	•	•	165.00	28.88	193.88
Fog lights - front and cornering lights	•	•	•	255.00	44.63	299.63
Mud flaps - front and rear	•	•	•	90.00	15.75	105.75
Parking sensors - rear	•	•	•	190.00	33.25	223.25
Privacy glass - rear (not with roof packs E or F) ²	•	•	•	210.00	36.75	246.75
Roof load rack preparation (not with medium or high roof packs)	•	•	•	70.00	12.25	82.25
Smoking pack - ashtray, cigarette lighter and cup holder	•	•	•	15.00	2.63	17.63
Spare wheel - steel	•	•	•	0.00	0.00	0.00
Sunroof - glass, electric, front (not with air conditioning pack C, roof ventilation/extraction-rear compartment, side door pack A, medium or high roof packs)	•	•	•	465.00	81.38	546.38
Tachograph - digital , includes console on dash	•	•	•	440.00	77.00	517.00
Towbar - fixed ball with 13 pin socket ³	•	•	•	360.00	63.00	423.00
Towbar - removable ball with 13 pin socket ³	•	•	•	450.00	78.75	528.75

• Options.
 - Not available.

† Calculated at 17.5% on all products.

¹ **Battery - second:** 72Ah with dual passenger seat, 80Ah with single passenger seat.

² **Privacy glass:** All rear and side windows from 'B' pillar back, where fitted, are dark tinted.

³ **Towbars:** An adaptor is available from Van Centres, to allow connection to twin 7 pin sockets. Only one front towing eye with towbars.



16" 'Miyato' alloy wheel.



17" 'Thunder' alloy wheel.



Cruise control.

Options subject to availability.

New Transporter kombi factory options.

	SWB		LWB	Manufacturer's RRP		
	T30	T32	T32	Basic retail excluding VAT £ †	VAT £ †	Total retail including VAT £ †
Factory fitted options. (continued)						
Trip computer (included with leather pack B and satellite navigation)	•	•	•	225.00	39.38	264.38
Tyre pressure warning light - (not with side door pack C)	•	•	•	50.00	8.75	58.75
Tyres - all weather, 215/65 R16 (84/102PS engines only, not with alloy wheels - 'Thunder')	•	•	•	195.00	34.13	229.13
Tyres - all weather (140PS engines only, not with alloy wheels - 'Thunder' or 'Canberra')	•	•	•	195.00	34.13	229.13
Options packs.						
Alarm pack A - perimeter with back-up horn (includes 2nd remote key) ⁴	•	•	•	130.00	22.75	152.75
Alarm pack B - with interior (cab only) and tow away protection (includes 2nd remote key) (not with medium or high roof packs or roof ventilation/extraction) ⁵	•	•	•	155.00	27.13	182.13
Appearance pack - electric windows, electrically adjustable, heated, folding and body coloured mirrors and body coloured bumpers (not with electric pack A or B)	•	•	•	625.00	109.38	734.38
Cab comfort pack ⁶	•	•	•	300.00	52.50	352.50
Electric pack A - electric windows, electrically heated and adjustable mirrors and internal central locking control (not with appearance pack)	•	•	•	330.00	57.75	387.75
Electric pack B - electric windows, electrically heated, adjustable and folding mirrors and internal central locking control (not with appearance pack)	•	•	•	415.00	72.63	487.63
Electric pack C - internal central locking control (only with appearance pack)	•	•	•	30.00	5.25	35.25
Lane change assist - includes visibility pack B, cruise control and multi-function display (SWB, only with appearance pack or electric pack B, not with rear door pack C or D or roof packs C, D, E or F)	•	•	-	1,300.00	227.50	1,527.50
Leather pack A - leather steering wheel, gearknob and gaiter	•	•	•	120.00	21.00	141.00
Leather pack B - multi-function leather steering wheel, gearknob and gaiter and radio control, includes trip computer	•	•	•	460.00	80.50	540.50
Satellite navigation A - CD colour screen, includes trip computer and radio upgrade RCD 310, MP3 compatible with AUX-IN and 4 speakers (not with digital radio) ^{4,7}	•	•	•	600.00	105.00	705.00
Satellite navigation B - DVD colour touch screen, includes trip computer and AUX-IN and 4 speakers (not with digital radio) ^{4,7}	•	•	•	1,770.00	309.75	2,079.75
Visibility pack A - headlamp washers, fluid level indicator and heated washer jets	•	•	•	170.00	29.75	199.75
Visibility pack B - rain sensor and automatic dimming rear view mirror	•	•	•	90.00	15.75	105.75



Lane change assist.



Airbags.



Fog lights with corning light function.



Multi-function steering wheel.



Satellite navigation A.



Satellite navigation B.

	SWB		LWB	Manufacturer's RRP		
	T30	T32	T32	Basic retail excluding VAT £ †	VAT £ †	Total retail including VAT £ †
Airbag packs.						
Airbags - side and front curtain airbags (not with seat packs E or E plus)	•	•	•	240.00	42.00	282.00
Audio options.						
DAB - digital radio reception (only with radio upgrade RCD 310, not with satellite navigation)	•	•	•	160.00	28.00	188.00
Radio upgrade - RCD 310, MP3 compatible with AUX-IN and 4 speakers (standard with satellite navigation)	•	•	•	75.00	13.13	88.13
Door packs.						
Rear doors - 250° hinges (only with rear door packs C or D or high roof packs)	-	-	•	250.00	43.75	293.75
Rear door pack B - tailgate without window (not with high roof packs) ⁹	•	•	•	-75.00	-13.13	-88.13
Rear door pack C - wing doors with heated rear windows and wash/wipe (included with roof packs E and F)	•	•	•	155.00	27.13	182.13
Rear door pack D - wing doors without windows (included with roof packs C and D) ⁹	•	•	•	50.00	8.75	58.75
Side door pack B - left and right, manual (not with high roof packs)	•	•	•	420.00	73.50	493.50
Side door pack C - left and right, electric, (includes 2nd remote key) (only with air conditioning pack B or C, not with air conditioning pack A, alarm packs or high roof packs)	•	•	•	1,040.00	182.00	1,222.00

- Options.
- Not available.

† Calculated at 17.5% on all products.

- ⁴ Battery uprated to 80Ah on 84/102PS engines, 95Ah on 140/180PS engines.
- ⁵ Battery uprated to 95Ah.
- ⁶ **Cab comfort pack:** 'Tasamo' fabric upholstery, carpet in cab, storage compartments in outer side of driver and passenger seats, vanity mirrors, sunglasses holder, interior light delay, 2 reading lights, instrument dimmer, grab handles on 'A' pillars, two tone horn and vent on 'B' pillar.
- ⁷ **Satellite navigation A and B:** Replaces radio/in-dash CD player, includes RDS radio function with single CD and CD changer control, where fitted (audio CDs cannot be played when using navigation disc).
- ⁹ Vehicles without through vision do not have a rear view mirror.

New Transporter kombi factory options. (continued)

	SWB			LWB	Manufacturer's RRP		
	T30		T32		Basic retail excluding VAT £ †	VAT £ †	Total retail including VAT £ †
	T30	T32	T32				
Heating and ventilation.							
Air conditioning pack A - 'Climatic', dash (not with heater - rear) ¹⁰	•	•	•	750.00	131.25	881.25	
Air conditioning pack B - 'Climatic', dash with rear heater ¹¹	•	•	•	1,150.00	201.25	1,351.25	
Air conditioning pack C - 'Climatic', dash and rear, with rear heater and rear roof vents (not with roof ventilation/extraction, sunroof or roof packs)	•	•	•	1,400.00	245.00	1,645.00	
Charcoal canister - for ventilation system	•	•	•	15.00	2.63	17.63	
Heater - rear (included with air conditioning packs B and C, not with air conditioning pack A)	•	•	•	410.00	71.75	481.75	
Parking heater A - with timer, includes battery - second ¹	•	•	•	1,700.00	297.50	1,997.50	
Parking heater B - with timer and remote control, includes battery - second ¹	•	•	•	1,900.00	332.50	2,232.50	
Roof ventilation/extraction - rear compartment (not with alarm pack B, sunroof or air conditioning pack C)	•	•	•	285.00	49.88	334.88	
Roof packs.							
Roof pack A - medium, white (not with alarm pack B, roof load rack preparation, sunroof or air conditioning pack C)	•	-	•	420.00	73.50	493.50	
Roof pack B - medium, body coloured (not with alarm pack B, roof load rack preparation, sunroof or air conditioning pack C) ⁸	•	-	•	510.00	89.25	599.25	
Roof pack C - high, white, includes high rear wing doors without windows (not with alarm pack B, roof load rack preparation, sunroof, air conditioning pack C or side door packs B or C) ⁹	-	-	•	830.00	145.25	975.25	
Roof pack D - high, body coloured, includes high rear wing doors without windows (not with alarm pack B, roof load rack preparation, sunroof, air conditioning pack C or side door packs B or C) ^{8,9}	-	-	•	940.00	164.50	1,104.50	
Roof pack E - high, white, includes high rear wing doors with heated rear windows and wash/wipe (not with alarm pack B, privacy glass, roof load rack preparation, sunroof, air conditioning pack C or side door packs B or C)	-	-	•	830.00	145.25	975.25	
Roof pack F - high, body coloured, includes high rear wing doors with heated rear windows and wash/wipe (not with alarm pack B, privacy glass, roof load rack preparation, sunroof, air conditioning pack C or side door packs B or C) ⁸	-	-	•	940.00	164.50	1,104.50	

	SWB			LWB	Manufacturer's RRP		
	T30		T32		Basic retail excluding VAT £ †	VAT £ †	Total retail including VAT £ †
	T30	T32	T32				
Seat packs.							
Seats - leatherette upholstery	•	•	•	25.00	4.38	29.38	
Seats - robust upholstery	•	•	•	80.00	14.00	94.00	
Seat pack A - driver's comfort seat (not with seat pack D) ¹²	•	•	•	55.00	9.63	64.63	
Seat pack B - driver and single passenger comfort seats (not with seat pack D) ¹³	•	•	•	160.00	28.00	188.00	
Seat pack C - heated driver and front passenger seats (only with air conditioning) ¹⁰	•	•	•	220.00	38.50	258.50	
Seat pack D - swivelling driver and single passenger seats (not with airbags - side and front curtain or seat packs A or B) ¹⁴	•	•	•	295.00	51.63	346.63	
Seat pack E - dual passenger seat (not with airbags - side and front curtain)	•	•	•	150.00	26.25	176.25	
Seat pack E plus - dual passenger seat with fold down tray in backrest (not with airbags - front and side curtain or seat pack B or D)	•	•	•	225.00	39.38	264.38	
Seat pack H - 1st row, single seat left with dual seat right ¹⁵	•	•	•	75.00	13.13	88.13	

- Options.
- Not available.

† Calculated at 17.5% on all products.

- ¹ **Battery - second:** 72Ah with dual passenger seat, 80Ah with single passenger seat.
- ⁸ Please confirm colour availability with your Volkswagen Van Centre.
- ⁹ Vehicles without through vision do not have a rear view mirror.
- ¹⁰ **Upated alternator:** 120A on 84/102PS engines, 150A on 140/180PS engines.
- ¹¹ **Upated alternator:** 140A on 84/102PS engines, 180A on 140/180PS engines.
- ¹² **Comfort seat:** Adds armrests (height adjustment and lumbar support standard for driver's seat).
- ¹³ **Comfort seats:** Adds armrests for both front seats, passenger height adjustment and lumbar support (height adjustment and lumbar support standard for driver's seat).
- ¹⁴ **Seat pack D:** Swivel seats include lumbar support and armrests but do not have height adjustment.
- ¹⁵ Dual bench seat includes ISOFIX child seat mountings.



Folding door mirrors.



Air conditioning.



Roof load rack preparation.



Parking sensors.



Cruise control.



Headlamp washers.

Options subject to availability.

New Transporter kombi dimensions and weights.

Kombi short wheelbase low and medium roof.

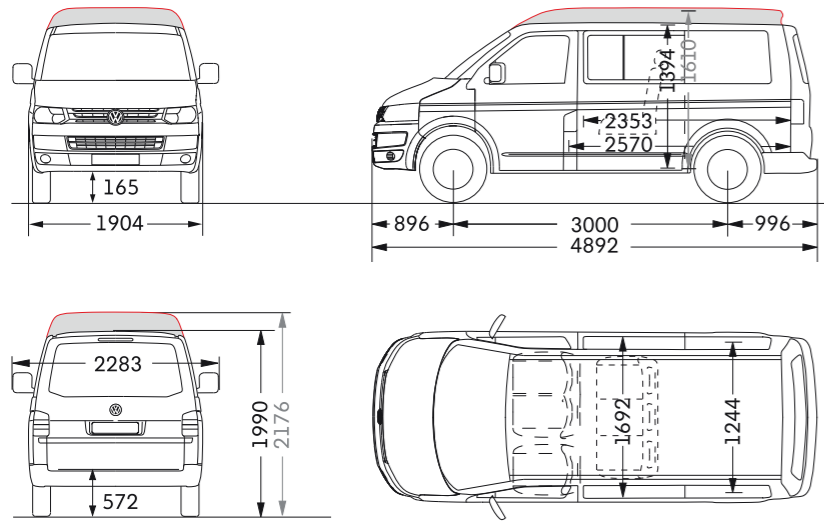

	Roof height	
	low	med
Wheelbase	3,000	3,000
Passenger compartment		
length	2,570	2,570
width	1,692	1,692
height	1,394	1,610
area	4.3m ²	4.3m ²
volume	5.8m ³	6.7m ³
Width		
(between wheel housings)	1,244	1,244
Lateral sliding door		
width	1,020	1,020
height	1,268	1,268
Tailgate		
width	1,486	1,486
height	1,295	1,295
Turning circle (wall to wall)	11.9m	11.9m
Load space		
(seat-back to doors)		
- 1st rear row	1,339	1,339

Dimensions in mm unless otherwise indicated.

Indicates optional roof height.

The height measurements listed here may vary by ± 50mm depending on equipment fitted. Please note vehicle drawings are not to scale.

Kombi long wheelbase low, medium and high roof.

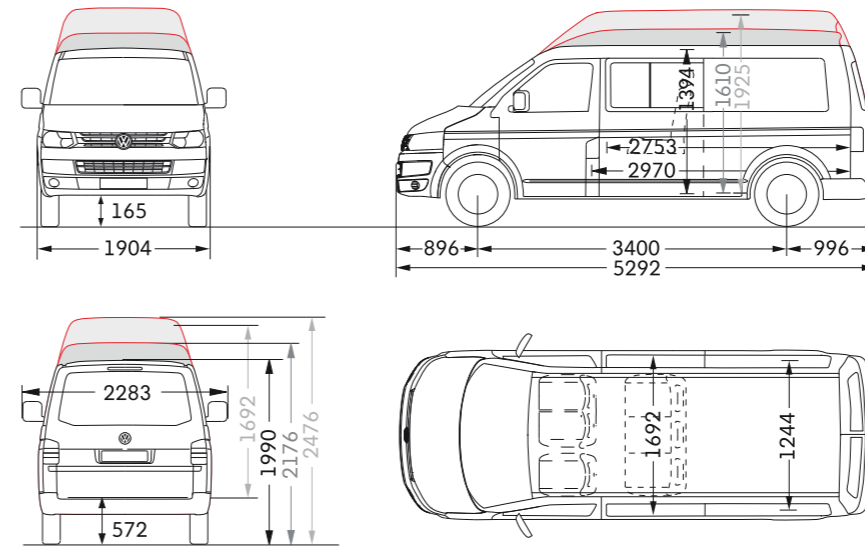

	Roof height		
	low	med	high
Wheelbase	3,400	3,400	3,400
Passenger compartment			
length	2,970	2,970	2,970
width	1,692	1,692	1,692
height	1,394	1,610	1,925
area	5.0m ²	5.0m ²	5.0m ²
volume	6.7m ³	7.8m ³	9.3m ³
Width			
(between wheel housings)	1,244	1,244	1,244
Lateral sliding door			
width	1,020	1,020	1,020
height	1,268	1,268	1,268
Tailgate			
width	1,486	1,486	-
height	1,295	1,295	-
Rear doors ¹			
width	-	-	1,486
height	-	-	1,692
Turning circle (wall to wall)	13.2m	13.2m	13.2m
Load space			
(seat-back to doors)			
- 1st rear row	1,739	1,739	1,739

¹ High roof only available with rear doors.

Dimensions in mm unless otherwise indicated.

Indicates optional roof height.

The height measurements listed here may vary by ± 50mm depending on equipment fitted. Please note vehicle drawings are not to scale.

Model	Gross vehicle weight kg	Engine	Axle load limit front / rear kg	Trailer weight braked / unbraked* kg	Gross train weight kg	Unladen weight** kg	Payload** kg
T30	3,000	84PS TDI	1,500 / 1,600	2,200 / 750	4,800	1,976	1,024
		140PS TDI	1,550 / 1,600	2,500 / 750	5,200	1,976	1,024
T32	3,200	102PS TDI	1,600 / 1,680	2,200 / 750	4,900	1,976	1,224
		140PS TDI	1,650 / 1,680	2,500 / 750	5,200	1,976	1,224
		140PS TDI DSG	1,650 / 1,680	2,500 / 750	5,300	1,982	1,218

Model	Gross vehicle weight kg	Engine	Axle load limit front / rear kg	Trailer weight braked / unbraked* kg	Gross train weight kg	Unladen weight** kg	Payload** kg
T32	3,200	102PS TDI	1,625 / 1,680	2,200 / 750	4,900	1,998	1,202
		140PS TDI	1,675 / 1,680	2,500 / 750	5,200	2,033	1,167
		180PS TDI	1,675 / 1,680	2,500 / 750	5,200	2,064	1,136

Trailer nose weight is 100kg.

Roof load limit (not medium) is: maximum 150kg (with 4 roof bars).
maximum 100kg (with 2 roof bars).

Tailgate load limit (where fitted) is maximum 75kg.

Vehicles with medium roof have no provision for roof loads.

* For 12% gradient.

** Unladen weight and payload includes approximately 90% fuel load and 75kg for driver.

Payload = gross vehicle weight - unladen weight.

Weights are for vehicles with standard specification. The addition of factory options or Volkswagen Van Centre fitted accessories may affect unladen weight and payload.

VAT information.

The VAT paid on kombi can usually be recovered if the vehicle is purchased by a VAT registered business. However VAT incurred on the purchase of vans fitted with windows and/or seats to the rear of the driver cannot be recovered unless the vehicle payload meets or exceeds 1,000kg. Otherwise VAT incurred on these vehicles is not available for recovery unless the vehicle is used for 100% business purposes. It is the customer's responsibility to deal with the VAT correctly. Customers should always seek professional advice to establish their own personal tax position.

New Transporter kombi engine specification.

	84PS TDI	102PS TDI	140PS TDI	180PS BiTDI
Engine type	Transverse, water cooled in line variable turbine geometry turbocharger with intercooler			Transverse, water cooled in line bi-turbo with intercooler
Mixture preparation/injection method	Common rail direct injection			BiTurbo common rail direct injection
EU exhaust emission standard	5			
No. of cylinders	4			
Cubic capacity, cm ³	1,968			
Output, PS at rpm	84 at 3,500	102 at 3,500	140 at 3,500	180 at 4,000
Torque, max. Nm/rpm	220/1,250-2,500	250/1,500-2,500	340/1,750-2,500	400/1,500-2,000
Diesel particulate filter	•	•	•	•
5-speed manual gearbox	•	•	-	-
6-speed manual gearbox	-	-	•	•
7-speed auto DSG	-	-	•	-
Front wheel drive	•	•	•	•

Electrics.

Alternator	110A
Battery	61Ah (330A)

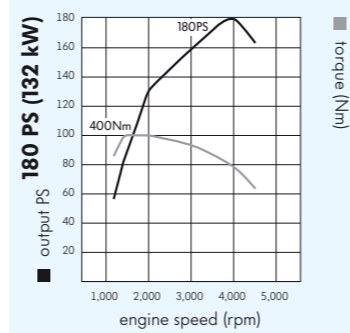
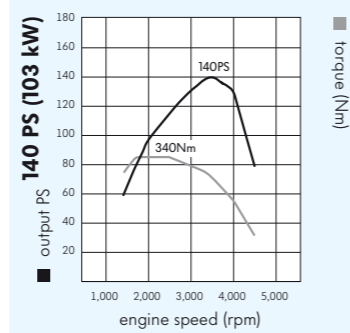
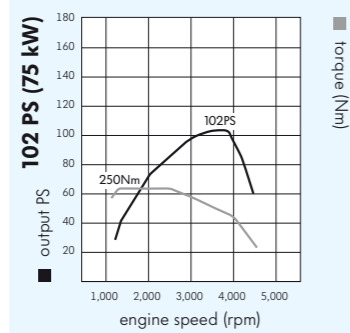
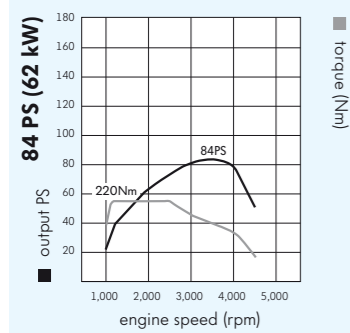

- Available
- Not available

New Transporter kombi fuel consumption, performance and CO₂ emissions.

Engine	Urban mpg (l/100km) ^{††}	Extra urban mpg (l/100km) ^{††}	Combined mpg (l/100km) ^{††}	Acceleration 0-62 mph	Top speed (where the law permits) mph	CO ₂ emissions (g/km)
Kombi with low roof and medium roof. (T30 and T32* short wheelbase and T32 long wheelbase only)						
84PS TDI	29.1 (9.7)	44.8 (6.3)	37.7 (7.5)	21.2	88	198
102PS TDI	29.1 (9.7)	44.8 (6.3)	37.7 (7.5)	16.5	94	198
140PS TDI	28.8 (9.8)	43.5 (6.5)	36.7 (7.7)	13.2	104	203
140PS TDI DSG	TBC	TBC	TBC	13.1	103	TBC
180PS BiTDI	28.8 (9.8)	42.2 (6.7)	36.2 (7.8)	10.4	114	205
Kombi with high roof. (T32 long wheelbase only)						
102PS TDI	28.8 (9.8)	40.9 (6.9)	35.8 (7.9)	16.6	90	208
140PS TDI	27.7 (10.2)	40.9 (6.9)	34.9 (8.1)	13.4	100	214
180PS BiTDI	28.8 (9.8)	39.8 (7.1)	34.9 (8.1)	10.7	109	214

* 84PS not available on T32 models.

†† With 50% payload and 80 litre fuel tank capacity.

New generation 7-speed Direct Shift Gearbox.

Unique to the commercial vehicle market, this highly acclaimed transmission system is now available for the first time on the new Transporter, making life much easier for the driver.

DSG operates via two automatic clutches: while one is engaged, the other is ready to accept the next gear. This enables changing of gears much faster than a standard automatic gearbox or manual – in less than four hundredths of a second – making it ideal for stop-start city driving.



The Crafter panel van.



Load floor showing accommodation of euro-pallets.

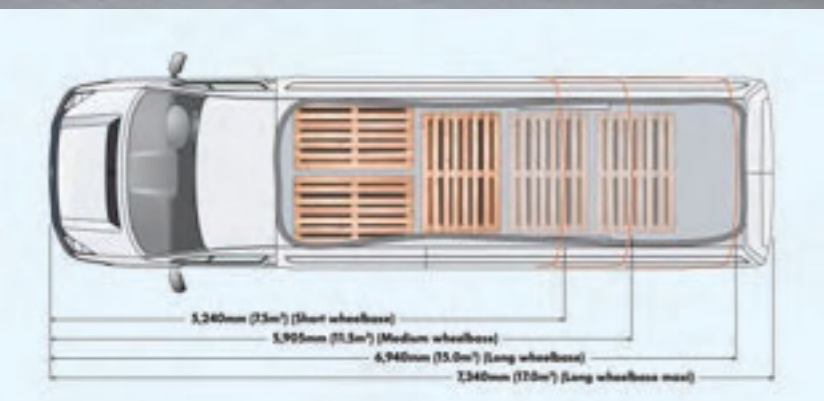

As the largest model in the Volkswagen range, the Crafter offers a number of key underlying strengths. Powerful BlueTDI engines with enough torque to satisfy the most demanding use, enough space to accommodate the most awkward load, and an array of features to satisfy the most discerning customer all combine to make the Crafter the vehicle of choice for a huge range of businesses.

And it's choice that marks the Crafter out as special. Because whatever your basic load-carrying requirement – length, weight or size – there's a model in the Crafter range that will do the job. It's not just about capability, though. Technological innovation also brings you a number of significant cost saving and environmental benefits.

Like the optional Stop-Start function, for example, activated by a control switch on the instrument panel, and designed to turn off your engine automatically when it's not needed – saving fuel and cutting vehicle emissions, noise and engine wear. Simply depress the clutch for the engine to restart automatically.

Driving becomes even more economical and environmentally-friendly with AdBlue® Technology, which works in combination with an SCR catalyst and long gear ratios to significantly reduce fuel consumption and nitrogen oxide emissions, ensuring the Crafter exceeds even the future Euro V standard.

More features and options are listed on the following pages, but standard features across the range include:

- ABS*, ESP* (load adjusting) and TCS*
- Class-leading side door – loads a euro-pallet sideways
- Full height steel bulkhead
- Load-lashing rings
- Thatcham category 1 alarm system.

*Please refer to the glossary on page 106 of this brochure.

More choices are detailed on the following pages, but the Crafter panel van's primary choices include:

- Load volumes from 7.5m³ to 17.0m³ (load area takes up to 5 euro-pallets)
- Payloads from 936kg up to 2,528kg
- Low, high or extra high roof
- Range of 4 BlueTDI common-rail diesel engines
- 3 wheelbase options
- 4 load lengths available
- Euro V engines (also EEV1) for a more efficient and environmentally friendly drive.

¹EEV: Enhanced Environmentally-friendly Vehicle standard.

Crafter panel van standard specifications.

Body.

- 25 litre AdBlue® tank
- 75 litre fuel tank with lockable cap
- Black bumpers with integrated front step
- Black wheel centre caps
- Externally adjustable external convex mirrors with indicators
- Front and rear towing eyes, (front only on CR50)
- Heat reflective glass
- Lateral side marker lights (LWB and LWB maxi)
- Sheet steel flooring
- Side sliding door on left
- Tyre repair kit and compressor
- Unglazed rear wing doors

Interior.

- | | | |
|--|---|--|
| <p>Cab area:</p> <ul style="list-style-type: none"> • 2 folding and pivoted sun visors • Driver's seat with height, reach and rake adjustment • Dual passenger seat with storage box and folding tray in backrest • Grab handles • 'Inca' fabric seat covers • Interior light (including 2 reading lights) • Rubber floor covering | <p>Storage:</p> <ul style="list-style-type: none"> - 5 drinks holders - Document holder on centre console - Glove compartment - Overhead storage (max load 5kg) - Storage compartment in right step - Storage compartments (open and closed) in doors - Storage tray in centre console - Storage tray on dashboard | <p>Rear:</p> <ul style="list-style-type: none"> • Door-activated interior lighting • Full height steel bulkhead without window • Interior side door entry step • Load lashing rings - 2 on 'B' pillar • Load lashing rings - floor mounted (SWB: 6, MWB: 8, LWB: 10, LWB maxi: 12) • Rear door interior release lever |
|--|---|--|

Functional.

- | | | |
|--|--|---|
| <ul style="list-style-type: none"> • 12V socket • Digital clock • Digital tachograph (CR50 only) • Dimmable dashboard illumination • Electric windows | <ul style="list-style-type: none"> • Manually controlled heating system with charcoal filter and air recirculation • Parking lights (SWB and MWB) • Radio/single CD player, MP3 compatible with 5 speakers • Remote central locking with 2 remote keys | <ul style="list-style-type: none"> • Rev counter • Speed limiter 56mph (90km/h) (CR50 models) • Warning buzzer for lights left on • Windscreen wiper with variable intermittent delay and wash/wiper system |
|--|--|---|

Technical.

- | | | |
|---|--|--|
| <ul style="list-style-type: none"> • Front and rear axle: <ul style="list-style-type: none"> - Anti-roll bar, front (front and rear on all CR50 and LWB CR35 panel van) - Front transverse leaf spring independent suspension - Rear rigid axle with leaf springs (CR30 and CR35 panel van only - single leaf, CR50 - triple leaf) - Telescopic shock absorbers | <ul style="list-style-type: none"> • Hydraulic brake system with front ventilated and rear solid disc brakes (front and rear ventilated on CR50) • Power steering • Rear wheels: <ul style="list-style-type: none"> - Single: CR30 and CR35 - Twin: CR50 | <ul style="list-style-type: none"> • Steel wheels: 5.5J x 16 (CR30 and CR50 only) 6.5J x 16 (CR35 only) • Tyres: 205/75 R16C (CR30 only) 235/65 R16C (CR35 only) 195/75 R16C (CR50 only) |
|---|--|--|

Safety and security.

- | | | |
|---|---|--|
| <ul style="list-style-type: none"> • 3rd brake light • ABS: Anti-lock Braking System • Automatic hazard lights activation under emergency braking • Brake pad wear, failure and fluid level indicators • Driver's airbag • EBA: Electronic Brake Assist • EBD: Electronic Brakeforce Distribution • EDL: Electronic Differential Lock | <ul style="list-style-type: none"> • ESP: Electronic Stabilisation Programme - load adjusting • Electronic steering wheel lock • Engine immobiliser 'Transponder' • Halogen main headlights with headlight range control • Height adjustable head restraints • Height adjustable seat belts for all outer cab seats • Rear fog light | <ul style="list-style-type: none"> • Seat belt warning light for driver • TCS: Traction Control System • Thatcham Category 1 alarm with interior (front and rear) and tow-away protection and back-up horn • Three point inertia reel seat belts for all seats |
|---|---|--|



Alarm system. Shows sliding bulkhead optional.



Fold down tray - integral to dual passenger seat.



Full height steel bulkhead.



Overhead console with two reading lights.



Overhead storage.



Radio/CD player.

Crafter panel van recommended retail prices.

Model	Manufacturer's RRP					Ins. group [#]	
	Basic retail excluding VAT £ †	VAT £ †	Total retail including VAT £ †	Total retail including OTR* excluding VAT £ † including VAT £ †			
Panel van short wheelbase.							
CR30	88PS BlueTDI 2EA3A5	18,000.00	3,150.00	21,150.00	18,750.00	21,999.75	7E
	109PS BlueTDI 2EA3B5	19,200.00	3,360.00	22,560.00	19,950.00	23,409.75	8E
Panel van medium wheelbase high roof.							
CR35	88PS BlueTDI 2ED4A5	22,800.00	3,990.00	26,790.00	23,550.00	27,639.75	9E
	109PS BlueTDI 2ED4B5	24,000.00	4,200.00	28,200.00	24,750.00	29,049.75	9E
	109PS BlueTDI Shiftmatic 2ED4BA	24,750.00	4,331.25	29,081.25	25,500.00	29,931.00	9E
	136PS BlueTDI 2ED4C5	24,900.00	4,357.50	29,257.50	25,650.00	30,107.25	9E
	136PS BlueTDI Shiftmatic 2ED4CA	25,650.00	4,488.75	30,138.75	26,400.00	30,988.50	9E
	163PS BlueTDI 2ED4D5	26,100.00	4,567.50	30,667.50	26,850.00	31,517.25	10E
CR50	109PS BlueTDI 2ED5B5	28,300.00	4,952.50	33,252.50	29,090.00	34,142.25	N/A
	109PS BlueTDI Shiftmatic 2ED5BA	29,050.00	5,083.75	34,133.75	29,840.00	35,023.50	N/A
	136PS BlueTDI 2ED5C5	29,230.00	5,115.25	34,345.25	30,020.00	35,235.00	N/A
	136PS BlueTDI Shiftmatic 2ED5CA	29,980.00	5,246.50	35,226.50	30,770.00	36,116.25	N/A
	163PS BlueTDI 2ED5D5	30,160.00	5,278.00	35,438.00	30,950.00	36,327.75	N/A
Panel van long wheelbase high roof.							
CR35	88PS BlueTDI 2EH4A5	23,350.00	4,086.25	27,436.25	24,100.00	28,286.00	9E
	109PS BlueTDI 2EH4B5	24,550.00	4,296.25	28,846.25	25,300.00	29,696.00	9E
	109PS BlueTDI Shiftmatic 2EH4BA	25,300.00	4,427.50	29,727.50	26,050.00	30,577.25	9E
	136PS BlueTDI 2EH4C5	25,450.00	4,453.75	29,903.75	26,200.00	30,753.50	9E
	136PS BlueTDI Shiftmatic 2EH4CA	26,200.00	4,585.00	30,785.00	26,950.00	31,634.75	10E
	163PS BlueTDI 2EH4D5	26,650.00	4,663.75	31,313.75	27,400.00	32,163.50	10E
CR50	109PS BlueTDI 2EH5B5	28,900.00	5,057.50	33,957.50	29,690.00	34,847.25	N/A
	109PS BlueTDI Shiftmatic 2EH5BA	29,650.00	5,188.75	34,838.75	30,440.00	35,728.50	N/A
	136PS BlueTDI 2EH5C5	29,830.00	5,220.25	35,050.25	30,620.00	35,940.00	N/A
	136PS BlueTDI Shiftmatic 2EH5CA	30,580.00	5,351.50	35,931.50	31,370.00	36,821.25	N/A
	163PS BlueTDI 2EH5D5	30,760.00	5,383.00	36,143.00	31,550.00	37,032.75	N/A
Panel van long wheelbase maxi** high roof.							
CR35	109PS BlueTDI 2EX4B5	24,800.00	4,340.00	29,140.00	25,550.00	29,989.75	9E
	109PS BlueTDI Shiftmatic 2EX4BA	25,550.00	4,471.25	30,021.25	26,300.00	30,871.00	9E
	136PS BlueTDI 2EX4C5	25,700.00	4,497.50	30,197.50	26,450.00	31,047.25	9E
	136PS BlueTDI Shiftmatic 2EX4CA	26,450.00	4,628.75	31,078.75	27,200.00	31,928.50	10E
	163PS BlueTDI 2EX4D5	26,900.00	4,707.50	31,607.50	27,650.00	32,457.25	10E
CR50	109PS BlueTDI 2EX5B5	29,400.00	5,145.00	34,545.00	30,190.00	35,434.75	N/A
	109PS BlueTDI Shiftmatic 2EX5BA	30,150.00	5,276.25	35,426.25	30,940.00	36,316.00	N/A
	136PS BlueTDI 2EX5C5	30,330.00	5,307.75	35,637.75	31,120.00	36,527.50	N/A
	136PS BlueTDI Shiftmatic 2EX5CA	31,080.00	5,439.00	36,519.00	31,870.00	37,408.75	N/A
	163PS BlueTDI 2EX5D5	31,260.00	5,470.50	36,730.50	32,050.00	37,620.25	N/A

*OTR (on the road) package for CR30 and CR35 panel vans includes the following:
 Delivery to retailer £550.00
 Number plates £20.00
 VAT £99.75
 Road fund licence £125.00
 First registration fee £55.00
Total £849.75

*OTR (on the road) package for CR50 panel vans (HGV, Band A) includes the following:
 Delivery to retailer £550.00
 Number plates £20.00
 VAT £99.75
 Road fund licence £165.00
 First registration fee £55.00
Total £889.75

Crafter panel van factory options.

	SWB low roof	MWB				LWB		LWB maxi		Manufacturer's RRP		
		CR30	CR35	CR50	CR35	CR50	CR35	CR50	Basic retail excluding VAT £ †	VAT £ †	Total retail including VAT £ †	
Paint options.												
Deep black paint - 3902	•	•	•	•	•	•	•	•	390.00	68.25	458.25	
Metallic paint - (includes wooden load floor cover)												
SWB	•	-	-	-	-	-	-	-	970.00	169.75	1,139.75	
MWB	-	•	•	-	-	-	-	-	1,030.00	180.25	1,210.25	
LWB	-	-	-	•	•	-	-	-	1,100.00	192.50	1,292.50	
LWB maxi	-	-	-	-	-	•	•	-	1,160.00	203.00	1,363.00	
Pearl effect paint - (includes wooden load floor cover)												
SWB	•	-	-	-	-	-	-	-	1,020.00	178.50	1,198.50	
MWB	-	•	•	-	-	-	-	-	1,080.00	189.00	1,269.00	
LWB	-	-	-	•	•	-	-	-	1,150.00	201.25	1,351.25	
LWB maxi	-	-	-	-	-	•	•	-	1,210.00	211.75	1,421.75	
Danish blue paint - 9506	•	•	•	•	•	•	•	•	105.00	18.38	123.38	
Factory fitted options.												
Alloy wheels - 16" (235/65 R16C) (CR30 only)	•	-	-	-	-	-	-	-	580.00	101.50	681.50	
Alloy wheels (CR35 only)	-	•	-	•	-	•	-	-	435.00	76.13	511.13	
Alternator - uprated 180A (not with battery - uprated or heated windscreen, included with air conditioning)	•	•	•	•	•	•	•	•	120.00	21.00	141.00	
Alternator/Battery - uprated (not with heated windscreen, tachograph - digital or CR50)	•	•	-	•	-	•	-	-	145.00	25.38	170.38	
Battery - uprated 110Ah (not with alternator - uprated, heated windscreen or tachograph - digital, not CR50)	•	•	-	•	-	•	-	-	35.00	6.13	41.13	
Cruise control	•	•	•	•	•	•	•	•	200.00	35.00	235.00	
Electric mirrors - heated and adjustable	•	•	•	•	•	•	•	•	175.00	30.63	205.63	
Fog lights - front, integrated in bumper	•	•	•	•	•	•	•	•	105.00	18.38	123.38	
Headlight washers (included with visibility pack)	•	•	•	•	•	•	•	•	185.00	32.38	217.38	
Heated windscreen (only with visibility pack, not with alternator - uprated, alternator/battery uprated or battery - uprated)	•	•	•	•	•	•	•	•	140.00	24.50	164.50	
Keys - 2 additional keys	•	•	•	•	•	•	•	•	55.00	9.63	64.63	
Load floor cover - wooden - (not with load lashing rings - deleted)												
SWB ¹	•	-	-	-	-	-	-	-	250.00	43.75	293.75	
MWB ¹	-	•	•	-	-	-	-	-	310.00	54.25	364.25	
LWB ¹	-	-	-	•	•	-	-	-	380.00	66.50	446.50	
LWB maxi ¹	-	-	-	-	-	•	•	-	440.00	77.00	517.00	

• Options.
 - Not available.
 s Standard equipment.
 † Calculated at 17.5% on all products.

¹ Load floor cover: Standard with metallic/pearl effect paint.

† Calculated at 17.5% on all products.

Insurance group: As advised by the Association of British Insurers (ABI). Please see www.thatcham.org/abigrouprating for more information.

** Maxi = extended rear overhang.



Multi-function steering wheel.



Full width rear step.



Sliding and tilting sunroof.

Options subject to availability.

Crafter panel van factory options. (continued)

	SWB	MWB		LWB		LWB maxi		Manufacturer's RRP		
	low roof	high roof						Basic retail excluding VAT £ †	VAT £ †	Total retail including VAT £ †
		CR30	CR35	CR50	CR35	CR50	CR35			
Factory fitted options. (continued)										
Load floor cover - rubber - (not with load lashing rings - deleted)										
SWB	•	-	-	-	-	-	-	340.00	59.50	399.50
MWB	-	•	•	-	-	-	-	425.00	74.38	499.38
LWB	-	-	-	•	•	-	-	530.00	92.75	622.75
LWB maxi	-	-	-	-	-	•	•	610.00	106.75	716.75
Load lashing rails - on load floor (only with load floor cover - wooden, not with load floor cover - rubber)	•	•	•	•	•	•	•	120.00	21.00	141.00
Load lashing rails - on side panel	•	•	•	•	•	•	•	120.00	21.00	141.00
Load lashing rails - on side panel and load floor (only with load floor cover - wooden, not with load floor cover - rubber)	•	•	•	•	•	•	•	240.00	42.00	282.00
Load lashing rails - on side panel and roof frame	•	•	•	•	•	•	•	215.00	37.63	252.63
Load lashing rails - on side panel, load floor and roof frame (only with load floor cover - wooden, not with load floor cover - rubber)	•	•	•	•	•	•	•	330.00	57.75	387.75
Load side lining - hardboard										
SWB	•	-	-	-	-	-	-	90.00	15.75	105.75
MWB	-	•	•	-	-	-	-	110.00	19.25	129.25
LWB	-	-	-	•	•	-	-	125.00	21.88	146.88
LWB maxi	-	-	-	-	-	•	•	140.00	24.50	164.50
Load side lining - plywood										
SWB	•	-	-	-	-	-	-	255.00	44.63	299.63
MWB	-	•	•	-	-	-	-	300.00	52.50	352.50
LWB	-	-	-	•	•	-	-	360.00	63.00	423.00
LWB maxi	-	-	-	-	-	•	•	410.00	71.75	481.75
Mud flaps - front	•	•	•	•	•	•	•	30.00	5.25	35.25
Mud flaps - front and rear	•	•	•	•	•	•	•	60.00	10.50	70.50
Parking brake - hill hold control (standard on Shiftmatic)	•	•	•	•	•	•	•	65.00	11.38	76.38
Parking sensors - front and rear (only with electric mirrors, not with step - rear, full width)	•	•	•	•	•	•	•	290.00	50.75	340.75
Reversing camera - includes 7" monitor on dashboard (not with parking sensors)	•	•	•	•	•	•	•	740.00	129.50	869.50
Reversing camera with front and rear parking sensors - includes 7" monitor on dashboard (only with electric mirrors, not with step - rear, full width)	•	•	•	•	•	•	•	1,025.00	179.38	1,204.38
Roof rack preparation	•	•	•	•	•	•	•	85.00	14.88	99.88
Roof ventilator - in passenger/load compartment	•	•	•	•	•	•	•	140.00	24.50	164.50
Satellite navigation A - colour screen with arrow navigation (CD)	•	•	•	•	•	•	•	1,060.00	185.50	1,245.50
Satellite navigation B - colour screen with map navigation (DVD)	•	•	•	•	•	•	•	1,660.00	290.50	1,950.50
Side marker lights (MWB only, standard on LWB and LWB maxi)	-	•	•	s	s	s	s	40.00	7.00	47.00

	SWB	MWB		LWB		LWB maxi		Manufacturer's RRP		
	low roof	high roof						Basic retail excluding VAT £ †	VAT £ †	Total retail including VAT £ †
		CR30	CR35	CR50	CR35	CR50	CR35			
Factory fitted options. (continued)										
Skylight - in passenger/load compartment, fixed										
SWB	•	-	-	-	-	-	-	65.00	11.38	76.38
MWB	-	•	•	-	-	-	-	125.00	21.88	146.88
LWB and LWB maxi	-	-	-	•	•	•	•	165.00	28.88	193.88
Spare wheel - steel (not with step - rear, full width)	•	•	•	•	•	•	•	0.00	0.00	0.00
Speed limiter 90km/h (standard with CR50)	•	•	s	•	s	•	s	40.00	7.00	47.00
Speed limiter 100km/h (not CR50)	•	•	-	•	-	•	-	40.00	7.00	47.00
Speed limiter 120km/h (not CR50)	•	•	-	•	-	•	-	40.00	7.00	47.00
Steering wheel - height and reach adjustable	•	•	•	•	•	•	•	65.00	11.38	76.38
Steering wheel - multi-function, includes trip computer (included with satellite navigation packs)	•	•	•	•	•	•	•	220.00	38.50	258.50
Step - rear, full width (not with parking sensors - front and rear, towbars or spare wheel - steel) ²	•	•	•	•	•	•	•	200.00	35.00	235.00
Step - rear, in bumper (not with towbars or MWB)	•	-	-	•	•	•	•	115.00	20.13	135.13
Step - rear, in bumper, includes side marker lights (MWB only, not with towbars)	-	•	•	-	-	-	-	125.00	21.88	146.88
Stop/Start function (only for manual)	•	•	•	•	•	•	•	400.00	70.00	470.00
Sunroof - in cab, sliding/tilting, electric (only with low roof)	•	•	•	-	-	-	-	470.00	82.25	552.25
Tachograph - digital (standard on CR50, not with alternator/battery - uprated or battery - uprated)	•	•	s	•	s	•	s	415.00	72.63	487.63
Temperature display - external (included with air conditioning, satellite navigation packs and steering wheel - multi-function)	•	•	•	•	•	•	•	90.00	15.75	105.75
Tyre pressure warning light (CR35 only)	-	•	-	•	-	•	-	270.00	47.25	317.25
Tyres - all weather	-	•	-	•	-	•	-	90.00	15.75	105.75
Options packs.										
Visibility pack - rain sensor, headlamp washers and automatic light sensor	•	•	•	•	•	•	•	310.00	54.25	364.25
Airbag packs.										
Airbag pack A - passenger	•	•	•	•	•	•	•	220.00	38.50	258.50
Airbag pack B - passenger, side and front curtain airbags (only with seat packs B or D)	•	•	•	•	•	•	•	765.00	133.88	898.88

• Options.
- Not available.
s Standard equipment.

² Step - rear: Full width step has only 1 front towing eye on CR35 models.

† Calculated at 17.5% on all products.



Bulkhead pack A. Shows optional second sliding door.



Air conditioning 'Climatic'.



Satellite navigation B.



16" alloy wheels.



Cruise control.



Electric mirrors. Image shows Parking sensors display.

Options subject to availability.

Crafter panel van factory options. (continued)

	SWB	MWB		LWB		LWB maxi		Manufacturer's RRP		
	low roof	high roof						Basic retail excluding VAT £ †	VAT £ †	Total retail including VAT £ †
	CR30	CR35	CR50	CR35	CR50	CR35	CR50			
Bulkhead packs.										
Bulkhead pack A - high with window	•	•	•	•	•	•	•	55.00	9.63	64.63
Bulkhead pack B - high with sliding window	•	•	•	•	•	•	•	175.00	30.63	205.63
Bulkhead pack E - deleted (not with load floor cover wooden/rubber or metallic/pearl effect paint)	•	•	•	•	•	•	•	0.00	0.00	0.00
Bulkhead pack F - sliding door in bulkhead, includes folding single passenger seat on bulkhead (not with roof packs)	-	•	•	•	•	•	•	715.00	125.13	840.13
Bulkhead pack G - sliding door in bulkhead, includes folding single passenger seat on bulkhead (only with roof pack B or C)	-	•	•	•	•	•	•	715.00	125.13	840.13
Door packs.										
Rear doors - wing doors with heated windows and wash/wipe, dipping rear view mirror and storage nets on rear doors	•	•	•	•	•	•	•	280.00	49.00	329.00
Rear doors - 270° hinges (not SWB)	-	•	•	•	•	•	•	265.00	46.38	311.38
Side door pack A - right only (no left door)	•	•	•	•	•	•	•	0.00	0.00	0.00
Side door pack B - left and right	•	•	•	•	•	•	•	380.00	66.50	446.50
Side door pack C - deleted, left	•	•	•	•	•	•	•	0.00	0.00	0.00
Heating and ventilation.										
Air conditioning - 'Climatic', includes temperature display, external	•	•	•	•	•	•	•	955.00	167.13	1,122.13
Roof packs.										
Roof pack A - low roof (MWB only)	-	•	•	-	-	-	-	-800.00	-140.00	-940.00
Roof pack B - extra high roof, white	-	•	•	•	•	•	•	1,180.00	206.50	1,386.50
Roof pack C - extra high roof, body-coloured (exterior only)	-	•	•	•	•	•	•	1,455.00	254.63	1,709.63

	SWB	MWB		LWB		LWB maxi		Manufacturer's RRP		
	low roof	high roof						Basic retail excluding VAT £ †	VAT £ †	Total retail including VAT £ †
	CR30	CR35	CR50	CR35	CR50	CR35	CR50			
Seat packs.										
Seats - 'Box' fabric upholstery	•	•	•	•	•	•	•	60.00	10.50	70.50
Seats - leatherette upholstery	•	•	•	•	•	•	•	35.00	6.13	41.13
Seat pack A - drivers seat with lumbar support	•	•	•	•	•	•	•	65.00	11.38	76.38
Seat pack B - driver and single passenger seat with lumbar support and inner armrest	•	•	•	•	•	•	•	130.00	22.75	152.75
Seat pack C - driver only with suspension and lumbar support	•	•	•	•	•	•	•	205.00	35.88	240.88
Seat pack D - driver and single passenger seat with suspension, lumbar support and inner armrest	•	•	•	•	•	•	•	335.00	58.63	393.63
Seat pack G - heated driver's seat	•	•	•	•	•	•	•	100.00	17.50	117.50
Seat pack H - heated driver and front passenger seats	•	•	•	•	•	•	•	200.00	35.00	235.00
Towbar packs.										
Towbar pack A - preparation, with socket ³	•	•	•	•	•	•	•	135.00	23.63	158.63
Towbar pack B - preparation with bracket, socket and cable ^{3,4}	•	•	•	•	•	•	•	210.00	36.75	246.75
Towbar pack C (towing weight 2.0t) - fixed ball with 13 pin socket (not with rear steps) ^{3,4,5}	•	•	•	•	•	•	•	330.00	57.75	387.75
Towbar pack D (towing weight 2.0t) - removable ball (not with rear steps) ^{3,4,5}	•	•	•	•	•	•	•	445.00	77.88	522.88
Towbar pack E (towing weight 2.0t) - jaw type with 13 pin socket (not with rear steps) ^{3,4,5}	•	•	•	•	•	•	•	340.00	59.50	399.50

- Options.
- Not available.
- s Standard equipment.

† Calculated at 17.5% on all products.

³ **Towbars:** In most circumstances, for commercial use, a tachograph will be required when towing equipment is fitted.

⁴ **Towbars:** Only 1 front towing eye on CR30 and CR35 models.

⁵ **Towbars:** An adaptor is available from Volkswagen Van Centres, to allow connection to twin 7 pin sockets.



Load floor cover.



Headlight washers.



Skylights in load compartment.



Towbars.



Fog lights.



Automatic light sensor.

Options subject to availability.

Crafter panel van dimensions and weights.

CR30 panel van short wheelbase low roof.

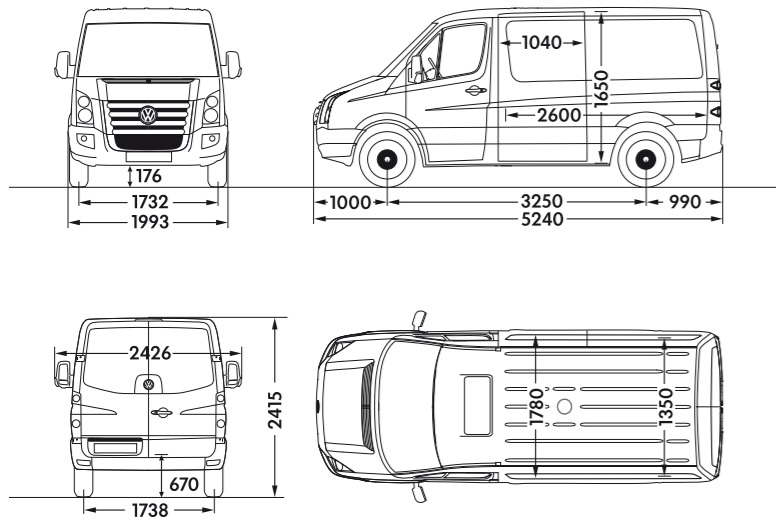

		Roof height
		low
Wheelbase		3,250
Load compartment volume		7.5m ³
Lateral sliding door	width	1,040
	height	1,520
Rear doors	width	1,565
	height	1,540
Turning circle (wall to wall)		12.3m

Dimensions in mm unless otherwise indicated.

CR35 / CR50 panel van medium wheelbase high and extra high roof.

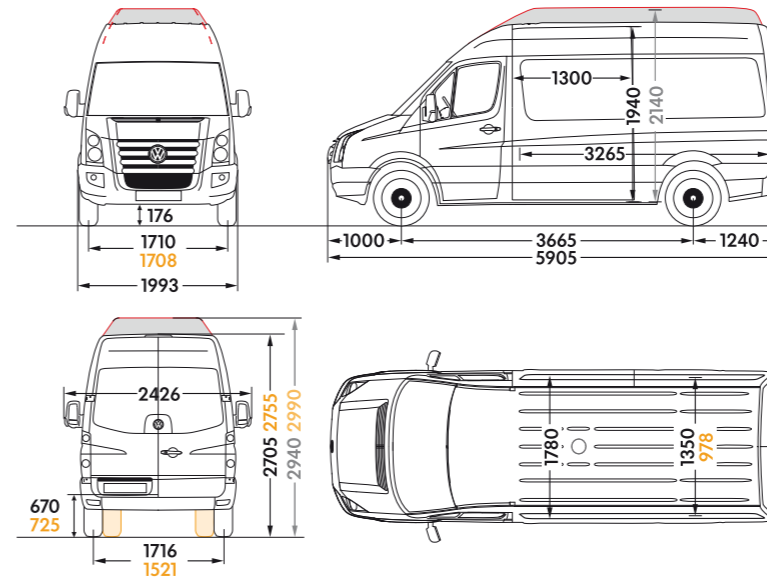

		Roof height	
		high	extra high
Wheelbase		3,665	3,665
Load compartment volume		11.0m ³	11.5m ³
Lateral sliding door	width	1,300	1,300
	height	1,820	1,820
Rear doors	width	1,565	1,565
	height	1,840	1,840
Turning circle (wall to wall)		13.6m	13.6m

Figures in orange indicate CR50 dimensions, where different.

Dimensions in mm unless otherwise indicated.

Indicates optional roof height.

The height measurements listed for dimensions are based on vehicles with standard specification, and may differ by approx ± 40mm depending on equipment fitted. Please note vehicle drawings are not to scale.

Gross vehicle weight	Engine	Axle load limit front / rear	Trailer weight braked / unbraked*	Gross train weight	Unladen weight**	Payload**
Model	kg	kg	kg	kg	kg	kg
CR30 3,000	88PS BlueTDI	1,650 / 1,800	2,000 / 750	5,000	2,064	936
	109PS BlueTDI	1,650 / 1,800	2,000 / 750	5,000	2,064	936

Gross vehicle weight	Engine	Axle load limit front / rear	Trailer weight braked / unbraked*	Gross train weight	Unladen weight**	Payload**
Model	kg	kg	kg	kg	kg	kg
CR35 3,500	88PS BlueTDI	1,650 / 2,250	2,000 / 750	5,500	2,188	1,312
	109PS BlueTDI	1,650 / 2,250	2,000 / 750	5,500	2,188	1,312
	109PS BlueTDI Shiftmatic	1,650 / 2,250	2,000 / 750	5,500	2,186	1,314
	136PS BlueTDI	1,650 / 2,250	2,000 / 750	5,500	2,188	1,312
	136PS BlueTDI Shiftmatic	1,650 / 2,250	2,000 / 750	5,500	2,186	1,314
	163PS BlueTDI	1,650 / 2,250	2,000 / 750	5,500	2,188	1,312
CR50 5,000	109PS BlueTDI	1,850 / 3,500	2,000 / 750	7,000	2,474	2,526
	109PS BlueTDI Shiftmatic	1,850 / 3,500	2,000 / 750	7,000	2,472	2,528
	136PS BlueTDI	1,850 / 3,500	2,000 / 750	7,000	2,474	2,526
	136PS BlueTDI Shiftmatic	1,850 / 3,500	2,000 / 750	7,000	2,472	2,528
	163PS BlueTDI	1,850 / 3,500	3,000 / 750	7,000	2,474	2,526

Roof load limit 300kg (low roof); 150kg (high roof).

Trailer nose weight 100kg.

All data is provisional.

* For 12% gradient.

** Unladen weight and payload includes approximately 90% fuel load and 75kg for driver.

Payload = gross vehicle weight - unladen weight.

Weights are for vehicles with standard specification. The addition of factory options or Volkswagen Van Centre fitted accessories may affect unladen weight and payload.

Please note: The CR35 model has a designed 'Trailer weight braked' of 2,800kg, so it is possible for an aftermarket braked towbar of up to 2,800kg to be fitted providing that the vehicle plating is also retro-uprated to a maximum of 2,800kg (and 'Gross train weight' of 6,300kg). Please contact your nearest Van Centre for details, including available axle ratio options to suit vehicle requirements.

Crafter panel van dimensions and weights. (continued)

CR35 / CR50 panel van long wheelbase high and extra high roof.

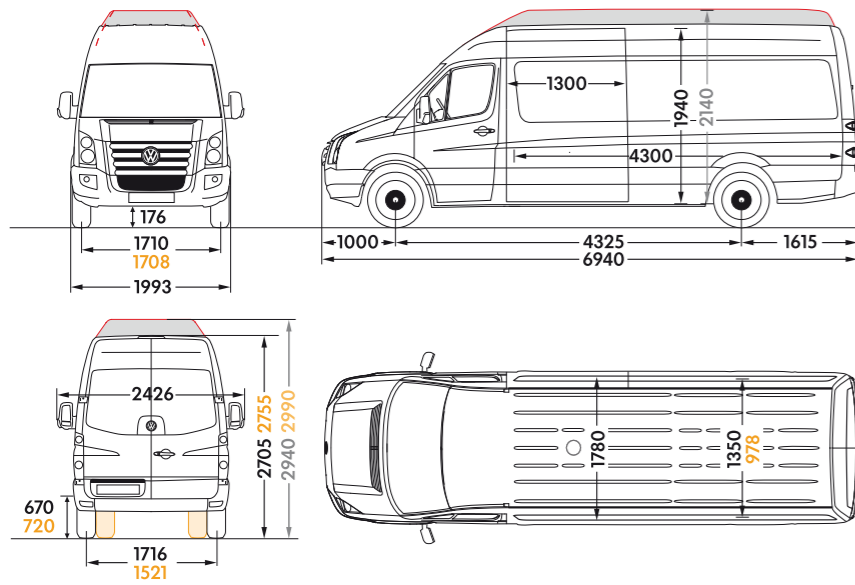

	Roof height	
	high	extra high
Wheelbase	4,325	4,325
Load compartment volume	14.0m ³	15.0m ³
Lateral sliding door width	1,300	1,300
height	1,820	1,820
Rear doors width	1,565	1,565
height	1,840	1,840
Turning circle (wall to wall)	15.6m	15.6m

Figures in orange indicate CR50 dimensions, where different.
Dimensions in mm unless otherwise indicated.

Indicates optional roof height.

CR35 / CR50 panel van long wheelbase maxi[†] high and extra high roof.

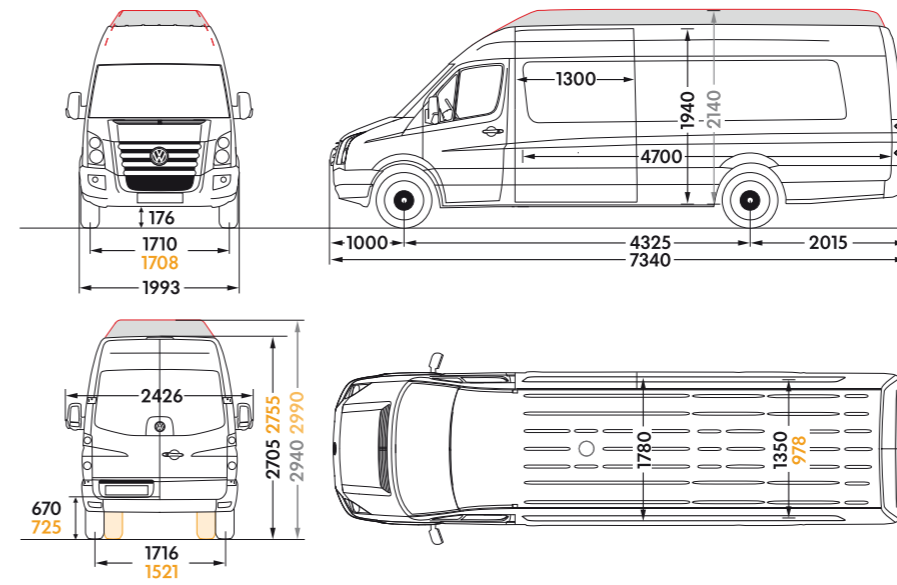

	Roof height	
	high	extra high
Wheelbase	4,325	4,325
Load compartment volume	15.5m ³	17m ³
Lateral sliding door width	1,300	1,300
height	1,820	1,820
Rear doors width	1,565	1,565
height	1,840	1,840
Turning circle (wall to wall)	15.6m	15.6m

Figures in orange indicate CR50 dimensions, where different.
Dimensions in mm unless otherwise indicated.

Indicates optional roof height.

The height measurements listed for dimensions are based on vehicles with standard specification, and may differ by approx ± 40mm depending on equipment fitted. Please note vehicle drawings are not to scale.

Gross vehicle weight	Engine	Axle load limit front / rear kg	Trailer weight braked / unbraked* kg	Gross train weight kg	Unladen weight** kg	Payload** kg
CR35 3,500	88PS BlueTDI	1,650 / 2,250	2,000 / 750	5,500	2,321	1,179
	109PS BlueTDI	1,650 / 2,250	2,000 / 750	5,500	2,321	1,179
	109PS BlueTDI Shiftmatic	1,650 / 2,250	2,000 / 750	5,500	2,319	1,181
	136PS BlueTDI	1,650 / 2,250	2,000 / 750	5,500	2,321	1,179
	136PS BlueTDI Shiftmatic	1,650 / 2,250	2,000 / 750	5,500	2,319	1,181
	163PS BlueTDI	1,650 / 2,250	2,000 / 750	5,500	2,321	1,179
CR50 5,000	109PS BlueTDI	1,850 / 3,500	2,000 / 750	7,000	2,641	2,359
	109PS BlueTDI Shiftmatic	1,850 / 3,500	2,000 / 750	7,000	2,639	2,361
	136PS BlueTDI	1,850 / 3,500	2,000 / 750	7,000	2,641	2,359
	136PS BlueTDI Shiftmatic	1,850 / 3,500	2,000 / 750	7,000	2,639	2,361
	163PS BlueTDI	1,850 / 3,500	3,000 / 750	7,000	2,641	2,359

Gross vehicle weight	Engine	Axle load limit front / rear kg	Trailer weight braked / unbraked* kg	Gross train weight kg	Unladen weight** kg	Payload** kg
CR35 3,500	109PS BlueTDI	1,650 / 2,250	2,000 / 750	5,500	2,373	1,127
	109PS BlueTDI Shiftmatic	1,650 / 2,250	2,000 / 750	5,500	2,371	1,129
	136PS BlueTDI	1,650 / 2,250	2,000 / 750	5,500	2,373	1,127
	136PS BlueTDI Shiftmatic	1,650 / 2,250	2,000 / 750	5,500	2,371	1,129
	163PS BlueTDI	1,650 / 2,250	2,000 / 750	5,500	2,373	1,127
	CR50 5,000	109PS BlueTDI	1,850 / 3,500	2,000 / 750	7,000	2,685
109PS BlueTDI Shiftmatic		1,850 / 3,500	2,000 / 750	7,000	2,683	2,317
136PS BlueTDI		1,850 / 3,500	2,000 / 750	7,000	2,685	2,315
136PS BlueTDI Shiftmatic		1,850 / 3,500	2,000 / 750	7,000	2,683	2,317
163PS BlueTDI		1,850 / 3,500	3,000 / 750	7,000	2,685	2,315

Roof load limit 300kg (low roof); 150kg (high roof).

Trailer nose weight 100kg.

All data is provisional.

† Maxi = extended rear overhang.

* For 12% gradient.

** Unladen weight and payload includes approximately 90% fuel load and 75kg for driver.

Payload = gross vehicle weight - unladen weight.

Weights are for vehicles with standard specification. The addition of factory options or Volkswagen Van Centre fitted accessories may affect unladen weight and payload.

Please note: The CR35 model has a designed 'Trailer weight braked' of 2,800kg, so it is possible for an aftermarket braked towbar of up to 2,800kg to be fitted providing that the vehicle plating is also retro-uprated to a maximum of 2,800kg (and 'Gross train weight' of 6,300kg). Please contact your nearest Van Centre for details, including available axle ratio options to suit vehicle requirements.

Crafter panel van engine specifications.

	88PS BlueTDI	109PS BlueTDI	136PS BlueTDI	163PS BlueTDI
Mixture preparation/injection method	Common-rail direct injection			
EU exhaust emission standard	EURO V and EEV [†]			
No. of cylinders	5			
Cubic capacity, cm ³	2,461			
Output, PS at rpm	88 at 3,300	109 at 3,300	136 at 3,500	163 at 3,500
Torque, max. Nm/rpm	250/1,900-2,300	300/1,900-2,300	330/2,000	360/2,200
Diesel particulate filter	•	•	•	•
6-speed manual gearbox	•	•	•	•
6-speed Shiftmatic gearbox	-	•	•	-
Rear wheel drive	•	•	•	•

Electrics.

Alternator	110A
Battery	72Ah (380A)
- CR30 and CR35	
- CR50	100Ah (450A)

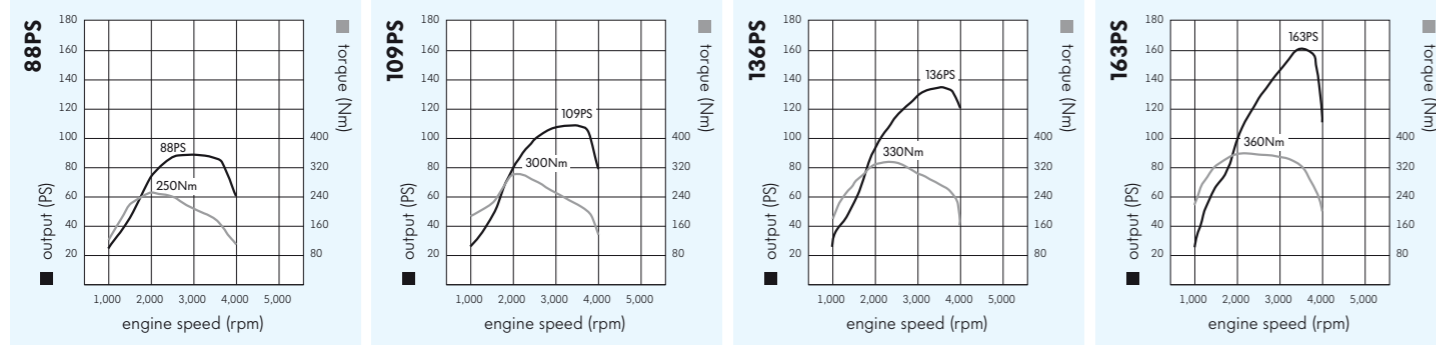

• Available

- Not available

[†] Enhanced Environmentally Friendly Vehicle - the emission measure below the maximum limit for EURO V standards.

Shiftmatic.

This lightweight gearbox combines the functionality of an automatic with the characteristics of a manual.

The Shiftmatic can be operated in either manual or automatic mode. In automatic mode all gears are selected automatically by the gearbox control unit, with a kick-down function for those times where extra acceleration is needed.

In manual mode, the driver pushes the gear lever forwards to change down, or backwards to change up, giving all the benefits of a manual gearbox without the need for a manual clutch – perfect for city driving.



Crafter panel van fuel consumption and performance.

Model	Engine		Urban ¹ mpg (l/100km)	Extra urban ¹ mpg (l/100km)	Combined ¹ mpg (l/100km)	Top speed (where the law permits) mph
Panel van with low roof. (short wheelbase)						
CR30	88PS BlueTDI	2.5 litre	22.4 (12.6)	33.6 (8.4)	28.5 (9.9)	85
	109PS BlueTDI	2.5 litre	23.5 (12.0)	34.4 (8.2)	29.4 (9.6)	91
Panel van with high roof. (medium wheelbase and long wheelbase)						
CR35	88PS BlueTDI	2.5 litre	22.4 (12.6)	33.6 (8.4)	28.5 (9.9)	85
	109PS BlueTDI	2.5 litre	23.5 (12.0)	34.4 (8.2)	29.4 (9.6)	91
	109PS BlueTDI Shiftmatic	2.5 litre	27.4 (10.3)	33.2 (8.5)	31.0 (9.1)	89
	136PS BlueTDI	2.5 litre	23.2 (12.2)	33.6 (8.4)	28.8 (9.8)	96
	136PS BlueTDI Shiftmatic	2.5 litre	27.4 (10.3)	33.2 (8.5)	31.0 (9.1)	93
	163PS BlueTDI	2.5 litre	23.0 (12.3)	33.6 (8.4)	28.8 (9.8)	99
CR50	109PS BlueTDI	2.5 litre	TBA	TBA	TBA	56 (83)
	109PS BlueTDI Shiftmatic	2.5 litre	TBA	TBA	TBA	56 (80)
	136PS BlueTDI	2.5 litre	TBA	TBA	TBA	56 (86)
	136PS BlueTDI Shiftmatic	2.5 litre	TBA	TBA	TBA	56 (84)
	163PS BlueTDI	2.5 litre	TBA	TBA	TBA	56 (94)
Panel van with optional extra high roof. (medium wheelbase and long wheelbase)						
CR35	88PS BlueTDI	2.5 litre	22.4 (12.6)	33.6 (8.4)	28.5 (9.9)	81
	109PS BlueTDI	2.5 litre	23.5 (12.0)	34.4 (8.2)	29.4 (9.6)	88
	109PS BlueTDI Shiftmatic	2.5 litre	27.4 (10.3)	33.2 (8.5)	31.0 (9.1)	89
	136PS BlueTDI	2.5 litre	23.2 (12.2)	33.6 (8.4)	28.8 (9.8)	91
	136PS BlueTDI Shiftmatic	2.5 litre	27.4 (10.3)	33.2 (8.5)	31.0 (9.1)	93
	163PS BlueTDI	2.5 litre	23.0 (12.3)	33.6 (8.4)	28.8 (9.8)	97
CR50	109PS BlueTDI	2.5 litre	TBA	TBA	TBA	56 (80)
	109PS BlueTDI Shiftmatic	2.5 litre	TBA	TBA	TBA	56 (78)
	136PS BlueTDI	2.5 litre	TBA	TBA	TBA	56 (83)
	136PS BlueTDI Shiftmatic	2.5 litre	TBA	TBA	TBA	56 (81)
	163PS BlueTDI	2.5 litre	TBA	TBA	TBA	56 (91)

¹ With 50% payload.

The figures listed apply to vehicles with manual gearbox, without optional extras.

Figures in square brackets show top speed for vehicles without speed limiter.

Figures above show vehicles fitted with standard axle ratio.

AdBlue®.

Driving becomes even more economical and environmentally-friendly with new AdBlue® Technology, which works in combination with an SCR catalyst and the Crafter's long gear ratios to significantly reduce fuel consumption and nitrogen oxide emissions.

All BlueTDI Crafters are equipped with AdBlue®, which fulfils the most demanding European emission standard, EEV (Enhanced Environmentally friendly Vehicle), and exceeds the Euro V emissions standard.

Stop-Start function.

The Crafter's Stop-Start function, available as an option, is activated by a switch on the instrument panel and is designed to turn off the engine automatically when it's not needed – saving fuel and cutting vehicle emissions, noise and engine wear.

The engine will stop whenever the vehicle is stationary for more than two seconds, providing the gearbox is in neutral and the clutch has been released, and will then restart automatically when the driver depresses the clutch. For safety, the system is automatically de-activated if the door or bonnet is opened or the seat belt is undone.

The Volkswagen Crafter kombi.



Load floor showing accommodation of euro-pallets.

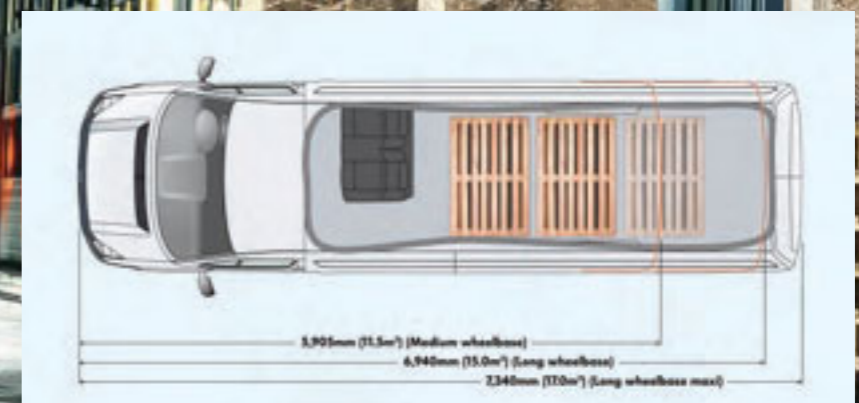

Enough space for up to five people and plenty of room for equipment behind the second row of seats. That's the beauty of the Crafter kombi, providing the ideal solution if you need to carry crew and your equipment to site each day, with extra load space available via the removable rear dual seat bench. A choice of three wheelbases includes medium, long and long wheelbase maxi, with two roof heights also available. Glass in the rear sliding door and opposite panel enables passengers to see out, while metal rear side panels protects your load from prying eyes.

A wide range of optional equipment enables you to customise your Crafter kombi to your exact requirements. Load lashing rails, for example, help keep your equipment secure, while heated, electric mirrors, headlight washers and a heated windscreen make journeys in the winter months so much easier. Features such as cruise control, a multi-function steering wheel and satellite navigation help make travel as relaxed and stress-free as possible, and there is also an optional reversing camera and parking sensors help you manoeuvre easily and safely into parking places.

Spacious and versatile, just look what you can expect to find in the Crafter kombi:

- ABS*
- Easy access through an extremely wide sliding door
- ESP* (load adjusting)
- Optional bulkhead behind second row of seats
- Removable dual seat bench in rear
- Seating for up to 4 passengers plus driver
- Thatcham category 1 alarm system

Other features and options are listed on the following pages.

* Please refer to the glossary on page 106 of this brochure.

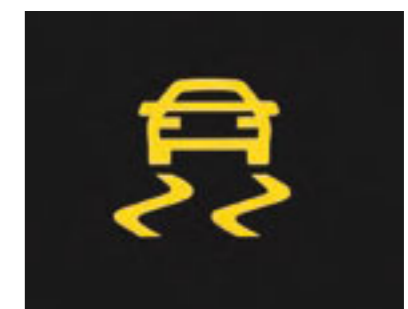

Crafter kombi standard specifications.

Body.

- 25 litre AdBlue® tank
- 75 litre fuel tank with lockable cap
- Black bumpers with integrated front step
- Black wheel centre caps
- Externally adjustable external convex mirrors with indicators
- Front and rear towing eyes, (front only on CR50)
- Heat reflective glass in side sliding door and opposite panel
- Lateral side marker lights (LWB and LWB maxi)
- Sheet steel flooring
- Side sliding door on left
- Tyre repair kit and compressor
- Unglazed rear wing doors

Interior.

- | | | |
|--|---|--|
| <p>Cab area:</p> <ul style="list-style-type: none"> • 2 folding and pivoted sun visors • Driver's seat with height, reach and rake adjustment • Dual passenger seat with storage box and folding tray in backrest • Grab handles • 'Inca' fabric seat covers • Interior light (including 2 reading lights) • Rubber floor covering | <p>Storage:</p> <ul style="list-style-type: none"> - 5 drinks holders - Document holder on centre console - Glove compartment - Overhead storage (max load 5kg) - Storage compartment in right step - Storage compartments (open and closed) in doors - Storage tray in centre console - Storage tray on dashboard | <p>Rear:</p> <ul style="list-style-type: none"> • Door-activated interior lighting • Dual passenger seat (removable) • Interior side door entry step • Load lashing rings - 2 on 'B' pillar • Load lashing rings - floor mounted (MWB: 8, LWB: 10, LWB maxi: 12) • Rear door interior release lever |
|--|---|--|

Functional.

- | | | |
|--|--|---|
| <ul style="list-style-type: none"> • 12V socket • Digital clock • Digital tachograph (CR50 only) • Dimmable dashboard illumination • Electric windows | <ul style="list-style-type: none"> • Manually controlled heating system with charcoal filter and air recirculation • Parking lights (MWB) • Radio/single CD player, MP3 compatible with 5 speakers • Remote central locking with 2 remote keys | <ul style="list-style-type: none"> • Rev counter • Speed limiter 56mph (90km/h) (CR50 models) • Warning buzzer for lights left on • Windscreen wiper with variable intermittent delay and wash/wiper system |
|--|--|---|

Technical.

- | | | |
|--|---|---|
| <ul style="list-style-type: none"> • Front and rear axle: <ul style="list-style-type: none"> - Anti-roll bar, front (front and rear on all CR50 and LWB CR35 kombi) - Front transverse leaf spring independent suspension - Rear rigid axle with leaf springs (CR35 kombi only - single leaf, CR50 - triple leaf) - Telescopic shock absorbers | <ul style="list-style-type: none"> • Hydraulic brake system with front ventilated and rear solid disc brakes (front and rear ventilated on CR50) • Power steering • Rear wheels: <ul style="list-style-type: none"> - Single: CR35 - Twin: CR50 | <ul style="list-style-type: none"> • Steel wheels: 5.5J x 16 (CR50 only)
6.5J x 16 (CR35 only) • Tyres: 235/65 R16C (CR35 only)
195/75 R16C (CR50 only) |
|--|---|---|

Safety and security.

- | | | |
|---|---|--|
| <ul style="list-style-type: none"> • 3rd brake light • ABS: Anti-lock Braking System • Automatic hazard lights activation under emergency braking • Brake pad wear, failure and fluid level indicators • Driver's airbag • EBA: Electronic Brake Assist • EBD: Electronic Brakeforce Distribution • EDL: Electronic Differential Lock | <ul style="list-style-type: none"> • ESP: Electronic Stabilisation Programme - load adjusting • Electronic steering wheel lock • Engine immobiliser 'Transponder' • Halogen main headlights with headlight range control • Height adjustable head restraints • Height adjustable seat belts for all outer cab seats • Rear fog light | <ul style="list-style-type: none"> • Seat belt warning light for driver • TCS: Traction Control System • Thatcham Category 1 alarm with interior (front and rear) and tow-away protection and back-up horn • Three point inertia reel seat belts for all seats |
|---|---|--|



Alarm system. Shows sliding bulkhead optional.



Fold down tray - integral to dual passenger seat.



Electric windows.



Overhead console with two reading lights.



Overhead storage.



Radio/CD player.

Crafter kombi recommended retail prices.

Model	Manufacturer's RRP					Ins. group [#]		
	Basic retail excluding VAT £ †	VAT £ †	Total retail including VAT £ †	Total retail including OTR*				
Kombi medium wheelbase high roof.								
CR35	109PS BlueTDI	2EDCB5	24,250.00	4,243.75	28,493.75	25,000.00	29,343.50	11E-T1
	109PS BlueTDI Shiftmatic	2EDCBA	25,000.00	4,375.00	29,375.00	25,750.00	30,224.75	11E-T1
	136PS BlueTDI	2EDCC5	25,150.00	4,401.25	29,551.25	25,900.00	30,401.00	11E-T1
	136PS BlueTDI Shiftmatic	2EDCCA	25,900.00	4,532.50	30,432.50	26,650.00	31,282.25	11E-T1
	163PS BlueTDI	2EDCD5	26,350.00	4,611.25	30,961.25	27,100.00	31,811.00	11E-T1
CR50	109PS BlueTDI	2EDKB5	26,970.00	4,719.75	31,689.75	27,760.00	32,579.50	N/A
	109PS BlueTDI Shiftmatic	2EDKBA	27,720.00	4,851.00	32,571.00	28,510.00	33,460.75	N/A
	136PS BlueTDI	2EDKC5	27,870.00	4,877.25	32,747.25	28,660.00	33,637.00	N/A
	136PS BlueTDI Shiftmatic	2EDKCA	28,620.00	5,008.50	33,628.50	29,410.00	34,518.25	N/A
	163PS BlueTDI	2EDKD5	29,070.00	5,087.25	34,157.25	29,860.00	35,047.00	N/A
Kombi long wheelbase high roof.								
CR35	109PS BlueTDI	2EHCB5	25,070.00	4,387.25	29,457.25	25,820.00	30,307.00	11E-T1
	109PS BlueTDI Shiftmatic	2EHCBA	25,820.00	4,518.50	30,338.50	26,570.00	31,188.25	11E-T1
	136PS BlueTDI	2EHCC5	25,970.00	4,544.75	30,514.75	26,720.00	31,364.50	11E-T1
	136PS BlueTDI Shiftmatic	2EHCCA	26,720.00	4,676.00	31,396.00	27,470.00	32,245.75	11E-T1
	163PS BlueTDI	2EHCD5	27,170.00	4,754.75	31,924.75	27,920.00	32,774.50	11E-T1
CR50	109PS BlueTDI	2EHKB5	27,790.00	4,863.25	32,653.25	28,580.00	33,543.00	N/A
	109PS BlueTDI Shiftmatic	2EHKBA	28,540.00	4,994.50	33,534.50	29,330.00	34,424.25	N/A
	136PS BlueTDI	2EHKC5	28,690.00	5,020.75	33,710.75	29,480.00	34,600.50	N/A
	136PS BlueTDI Shiftmatic	2EHKCA	29,440.00	5,152.00	34,592.00	30,230.00	35,481.75	N/A
	163PS BlueTDI	2EHKD5	29,890.00	5,230.75	35,120.75	30,680.00	36,010.50	N/A
Kombi long wheelbase maxi** high roof.								
CR35	109PS BlueTDI	2EXCB5	25,610.00	4,481.75	30,091.75	26,360.00	30,941.50	11E-T1
	109PS BlueTDI Shiftmatic	2EXCBA	26,360.00	4,613.00	30,973.00	27,110.00	31,822.75	11E-T1
	136PS BlueTDI	2EXCC5	26,510.00	4,639.25	31,149.25	27,260.00	31,999.00	11E-T1
	136PS BlueTDI Shiftmatic	2EXCCA	27,260.00	4,770.50	32,030.50	28,010.00	32,880.25	11E-T1
	163PS BlueTDI	2EXCD5	27,710.00	4,849.25	32,559.25	28,460.00	33,409.00	11E-T1
CR50	109PS BlueTDI	2EXKB5	28,330.00	4,957.75	33,287.75	29,120.00	34,177.50	N/A
	109PS BlueTDI Shiftmatic	2EXKBA	29,080.00	5,089.00	34,169.00	29,870.00	35,058.75	N/A
	136PS BlueTDI	2EXKC5	29,230.00	5,115.25	34,345.25	30,020.00	35,235.00	N/A
	136PS BlueTDI Shiftmatic	2EXKCA	29,980.00	5,246.50	35,226.50	30,770.00	36,116.25	N/A
	163PS BlueTDI	2EXKD5	30,430.00	5,325.25	35,755.25	31,220.00	36,645.00	N/A

*OTR (on the road) package for CR35 kombi includes the following:
 Delivery to retailer £550.00
 Number plates £20.00
 VAT £99.75
 Road fund licence £125.00
 First registration fee £55.00
Total £849.75

*OTR (on the road) package for CR50 kombi (HGV, Band A) includes the following:
 Delivery to retailer £550.00
 Number plates £20.00
 VAT £99.75
 Road fund licence £165.00
 First registration fee £55.00
Total £889.75

Crafter kombi factory options.

	MWB		LWB		LWB maxi		Manufacturer's RRP		
	CR35	CR50	CR35	CR50	CR35	CR50	Basic retail excluding VAT £ †	VAT £ †	Total retail including VAT £ †
Paint options.									
Deep black paint - 3902	•	•	•	•	•	•	390.00	68.25	458.25
Metallic paint	•	•	•	•	•	•	720.00	126.00	846.00
Pearl effect paint	•	•	•	•	•	•	770.00	134.75	904.75
Danish blue paint - 9506	•	•	•	•	•	•	105.00	18.38	123.38
Factory fitted options.									
Alloy wheels (CR35 only)	•	-	•	-	•	-	435.00	76.13	511.13
Alternator - uprated 180A (not with battery - uprated or heated windscreen, included with air conditioning)	•	•	•	•	•	•	120.00	21.00	141.00
Alternator/Battery - uprated (not with heated windscreen, tachograph - digital or CR50)	•	-	•	-	•	-	145.00	25.38	170.38
Battery - uprated 110Ah (not with alternator - uprated, heated windscreen or tachograph - digital, not CR50)	•	-	•	-	•	-	35.00	6.13	41.13
Bulkhead at C-pillar - includes load floor cover - rubber, load side lining - plywood and roof lining (not with roof packs)									
CR35 MWB only	•	-	-	-	-	-	1,345.00	235.38	1,580.38
CR35 LWB only	-	-	•	-	-	-	1,490.00	260.75	1,750.75
CR35 LWB maxi only	-	-	-	-	•	-	1,600.00	280.00	1,880.00
Cruise control	•	•	•	•	•	•	200.00	35.00	235.00
Electric mirrors - heated and adjustable	•	•	•	•	•	•	175.00	30.63	205.63
Fog lights - front, integrated in bumper	•	•	•	•	•	•	105.00	18.38	123.38
Headlight washers (included with visibility pack)	•	•	•	•	•	•	185.00	32.38	217.38
Heated windscreen (only with visibility pack, not with alternator - uprated, alternator/battery uprated or battery - uprated)	•	•	•	•	•	•	140.00	24.50	164.50
Keys - 2 additional keys	•	•	•	•	•	•	55.00	9.63	64.63
Load floor cover - rubber - (included with bulkhead on CR35 models only)									
MWB	•	•	-	-	-	-	130.00	22.75	152.75
LWB	-	-	•	•	-	-	160.00	28.00	188.00
LWB maxi	-	-	-	-	•	•	185.00	32.38	217.38

- Options.
- Not available.
- s Standard equipment.
- † Calculated at 17.5% on all products.

† Calculated at 17.5% on all products.

Insurance group: As advised by the Association of British Insurers (ABI). Please see www.thatcham.org/abigrouprating for more information.

** Maxi = extended rear overhang.



Multi-function steering wheel.



Full width rear step.



Sliding and tilting sunroof.

Options subject to availability.

Crafter kombi factory options. (continued)

	MWB		LWB		LWB maxi		Manufacturer's RRP		
	high roof						Basic retail excluding VAT £ †	VAT £ †	Total retail including VAT £ †
	CR35	CR50	CR35	CR50	CR35	CR50			
Factory fitted options. (continued)									
Load lashing rails - on side panel (only with bulkhead) CR35 models only	•	-	•	-	•	-	120.00	21.00	141.00
Load lashing rails - on side panel and roof frame (only with bulkhead) CR35 models only	•	-	•	-	•	-	215.00	37.63	252.63
Load side lining - plywood, included with bulkhead on CR35 models									
MWB	•	•	-	-	-	-	210.00	36.75	246.75
LWB	-	-	•	•	-	-	260.00	45.50	305.50
LWB maxi	-	-	-	-	•	•	310.00	54.25	364.25
Mud flaps - front	•	•	•	•	•	•	30.00	5.25	35.25
Mud flaps - front and rear	•	•	•	•	•	•	60.00	10.50	70.50
Parking brake - hill hold control (standard on Shiftmatic)	•	•	•	•	•	•	65.00	11.38	76.38
Parking sensors - front and rear (only with electric mirrors, not with step - rear, full width)	•	•	•	•	•	•	290.00	50.75	340.75
Reversing camera - includes 7" monitor on dashboard (not with parking sensors)	•	•	•	•	•	•	740.00	129.50	869.50
Reversing camera with front and rear parking sensors - includes 7" monitor on dashboard (only with electric mirrors, not with step - rear, full width)	•	•	•	•	•	•	1,025.00	179.38	1,204.38
Roof rack preparation	•	•	•	•	•	•	85.00	14.88	99.88
Roof ventilator - in passenger/load compartment (not with bulkhead)	•	•	•	•	•	•	140.00	24.50	164.50
Satellite navigation A - colour screen with arrow navigation (CD)	•	•	•	•	•	•	1,060.00	185.50	1,245.50
Satellite navigation B - colour screen with map navigation (DVD)	•	•	•	•	•	•	1,660.00	290.50	1,950.50
Side marker lights (MWB only, standard on LWB and LWB maxi, included with step-rear, in bumper)	•	•	s	s	s	s	40.00	7.00	47.00
Skylight - in passenger/load compartment, fixed									
MWB (not with bulkhead)	•	•	-	-	-	-	125.00	21.88	146.88
LWB and LWB maxi (not with bulkhead)	-	-	•	•	•	•	135.00	23.63	158.63
Spare wheel - steel (not with step - rear, full width)	•	•	•	•	•	•	0.00	0.00	0.00
Speed limiter 90km/h (standard with CR50)	•	s	•	s	•	s	40.00	7.00	47.00
Speed limiter 100km/h	•	-	•	-	•	-	40.00	7.00	47.00
Speed limiter 120km/h (not CR50)	•	-	•	-	•	-	40.00	7.00	47.00
Steering wheel - height and reach adjustable	•	•	•	•	•	•	65.00	11.38	76.38
Steering wheel - multi-function, includes trip computer (included with satellite navigation packs)	•	•	•	•	•	•	220.00	38.50	258.50

	MWB		LWB		LWB maxi		Manufacturer's RRP		
	high roof						Basic retail excluding VAT £ †	VAT £ †	Total retail including VAT £ †
	CR35	CR50	CR35	CR50	CR35	CR50			
Factory fitted options. (continued)									
Step - rear, full width (not with parking sensors - front and rear, towbars or spare wheel - steel) ¹	•	•	•	•	•	•	200.00	35.00	235.00
Step - rear, in bumper (not with towbars or MWB)	-	-	•	•	•	•	115.00	20.13	135.13
Step - rear, in bumper, includes side marker lights (MWB only, not with towbars)	•	•	-	-	-	-	125.00	21.88	146.88
Stop-Start function (only for manual)	•	•	•	•	•	•	400.00	70.00	470.00
Sunroof - in cab, sliding/tilting, electric (only with low roof, not with bulkhead)	•	•	-	-	-	-	470.00	82.25	552.25
Tachograph - digital (standard on CR50, not with alternator/battery - uprated or battery - uprated)	•	s	•	s	•	s	415.00	72.63	487.63
Temperature display - external (included with air conditioning, satellite navigation packs and steering wheel - multi-function)	•	•	•	•	•	•	90.00	15.75	105.75
Tyre pressure warning light (CR35 only)	•	-	•	-	•	-	270.00	47.25	317.25
Tyres - all weather	•	-	•	-	•	-	90.00	15.75	105.75
Options packs.									
Visibility pack - rain sensor, headlamp washers and automatic light sensor	•	•	•	•	•	•	310.00	54.25	364.25
Airbag packs.									
Airbag pack A - passenger	•	•	•	•	•	•	220.00	38.50	258.50
Airbag pack B - passenger, side and front curtain airbags (only with seat packs B or D)	•	•	•	•	•	•	765.00	133.88	898.88
Door packs.									
Rear doors - wing doors with heated windows and wash/wipe, dipping rear view mirror and storage nets on rear doors	•	•	•	•	•	•	280.00	49.00	329.00
Rear doors - 270° hinges	•	•	•	•	•	•	265.00	46.38	311.38

- Options.
- Not available.
- s Standard equipment.

¹ Step - rear: Full width step has only 1 front towing eye on CR35 models.

† Calculated at 17.5% on all products.



Reversing camera.



Reversing camera display.



Air conditioning 'Climatic'.



Satellite navigation B.



Cruise control.



Electric mirrors. Image shows Parking sensors display.

Options subject to availability.

Crafter kombi factory options. (continued)

	MWB		LWB		LWB maxi		Manufacturer's RRP		
	high roof						Basic retail excluding VAT £ †	VAT £ †	Total retail including VAT £ †
	CR35	CR50	CR35	CR50	CR35	CR50			
Heating and ventilation.									
Air conditioning - 'Climatic', includes temperature display, external ²	•	•	•	•	•	•	955.00	167.13	1,122.13
Roof packs.									
Roof pack A - low roof (MWB only, not with bulkhead)	•	•	-	-	-	-	-800.00	-140.00	-940.00
Roof pack B - extra high roof, white (not with bulkhead)	•	•	•	•	•	•	1,180.00	206.50	1,386.50
Roof pack C - extra high roof, body-coloured (exterior only, not with bulkhead)	•	•	•	•	•	•	1,455.00	254.63	1,709.63
Seat packs.									
Seats - 'Box' fabric upholstery	•	•	•	•	•	•	60.00	10.50	70.50
Seats - leatherette upholstery	•	•	•	•	•	•	35.00	6.13	41.13
Seat pack A - drivers seat with lumbar support	•	•	•	•	•	•	65.00	11.38	76.38
Seat pack B - driver and single passenger seat with lumbar support and inner armrest	•	•	•	•	•	•	130.00	22.75	152.75
Seat pack C - driver only with suspension and lumbar support	•	•	•	•	•	•	205.00	35.88	240.88
Seat pack D - driver and single passenger seat with suspension, lumbar support and inner armrest	•	•	•	•	•	•	335.00	58.63	393.63
Seat pack G - heated driver's seat	•	•	•	•	•	•	100.00	17.50	117.50
Seat pack H - heated driver and front passenger seats (only with seat packs B or D)	•	•	•	•	•	•	200.00	35.00	235.00
Towbar packs.									
Towbar pack A - preparation, with socket ³	•	•	•	•	•	•	135.00	23.63	158.63
Towbar pack B - preparation with bracket, socket and cable ^{3,4}	•	•	•	•	•	•	210.00	36.75	246.75
Towbar pack C (towing weight 2.0t)	•	•	•	•	•	•			
- fixed ball with 13 pin socket (not with rear steps) ^{3,4,5}	•	•	•	•	•	•	330.00	57.75	387.75
Towbar pack D (towing weight 2.0t)	•	•	•	•	•	•			
- removable ball (not with rear steps) ^{3,4,5}	•	•	•	•	•	•	445.00	77.88	522.88
Towbar pack E (towing weight 2.0t)	•	•	•	•	•	•			
- jaw type with 13 pin socket (not with rear steps) ^{3,4,5}	•	•	•	•	•	•	340.00	59.50	399.50

• Options.

- Not available.

s Standard equipment.

† Calculated at 17.5% on all products.

² **Air conditioning:** Alternator uprated to 180A.

³ **Towbars:** In most circumstances, for commercial use, a tachograph will be required when towing equipment is fitted.

⁴ **Towbars:** Only 1 front towing eye on CR35 models.

⁵ **Towbars:** An adaptor is available from Volkswagen Van Centres, to allow connection to twin 7 pin sockets.



Load floor cover.



Headlight washers.



Skylights in load compartment.

Crafter kombi dimensions and weights.

CR35 / CR50 kombi medium wheelbase high and extra high roof.

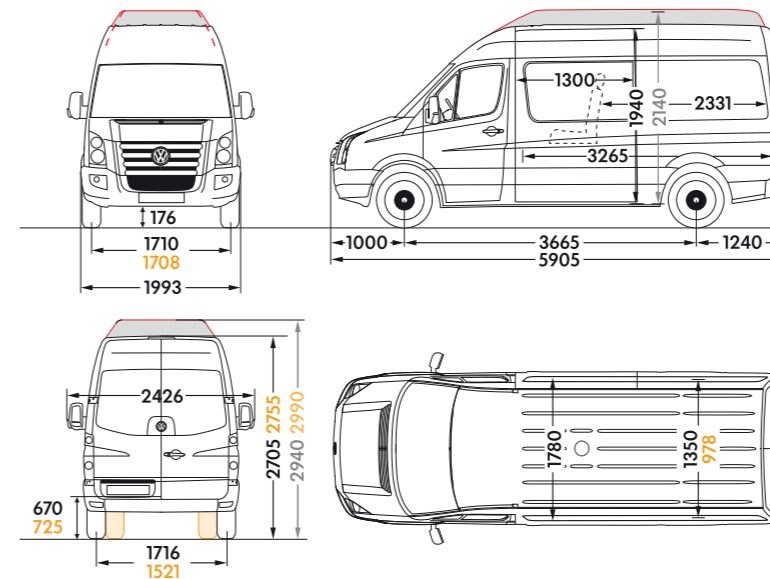

	Roof height	
	high	extra high
Wheelbase	3,665	3,665
Load compartment volume	11.0m ³ *	11.5m ³ *
Lateral sliding door width	1,300	1,300
height	1,820	1,820
Rear doors width	1,565	1,565
height	1,840	1,840
Turning circle (wall to wall)	13.6m	13.6m

Figures in orange indicate CR50 dimensions, where different.
Dimensions in mm unless otherwise indicated.

□ Indicates optional roof height.

* Dual passenger seat in rear is not excluded from volume.

The height measurements listed for dimensions are based on vehicles with standard specification, and may differ by approx ± 40mm depending on equipment fitted.

Dual passenger seat in rear is removable.

Please note vehicle drawings are not to scale.

Model	Gross vehicle weight kg	Engine	Axle load limit front / rear kg	Trailer weight braked / unbraked* kg	Gross train weight kg	Unladen weight** kg	Payload** kg
CR35	3,500	109PS BlueTDI	1,650 / 2,250	2,000 / 750	5,500	2,285	1,215
		109PS BlueTDI Shiftmatic	1,650 / 2,250	2,000 / 750	5,500	2,283	1,217
		136PS BlueTDI	1,650 / 2,250	2,000 / 750	5,500	2,285	1,215
		136PS BlueTDI Shiftmatic	1,650 / 2,250	2,000 / 750	5,500	2,283	1,217
		163PS BlueTDI	1,650 / 2,250	2,000 / 750	5,500	2,285	1,215
CR50	5,000	109PS BlueTDI	1,850 / 3,500	2,000 / 750	7,000	2,571	2,429
		109PS BlueTDI Shiftmatic	1,850 / 3,500	2,000 / 750	7,000	2,569	2,431
		136PS BlueTDI	1,850 / 3,500	2,000 / 750	7,000	2,571	2,429
		136PS BlueTDI Shiftmatic	1,850 / 3,500	2,000 / 750	7,000	2,569	2,431
		163PS BlueTDI	1,850 / 3,500	3,000 / 750	7,000	2,571	2,429

Roof load limit 300kg (low roof); 150kg (high roof).

Trailer nose weight 100kg.

All data is provisional.

* For 12% gradient.

** Unladen weight and payload includes approximately 90% fuel load and 75kg for driver.

Payload = gross vehicle weight - unladen weight.

Weights are for vehicles with standard specification. The addition of factory options or Volkswagen Van Centre fitted accessories may affect unladen weight and payload.

Please note: The CR35 model has a designed 'Trailer weight braked' of 2,800kg, so it is possible for an aftermarket braked towbar of up to 2,800kg to be fitted providing that the vehicle plating is also retro-uprated to a maximum of 2,800kg (and 'Gross train weight' of 6,300kg). Please contact your nearest Van Centre for details, including available axle ratio options to suit vehicle requirements.

Crafter kombi dimensions and weights. (continued)

CR35 / CR50 kombi long wheelbase high and extra high roof.

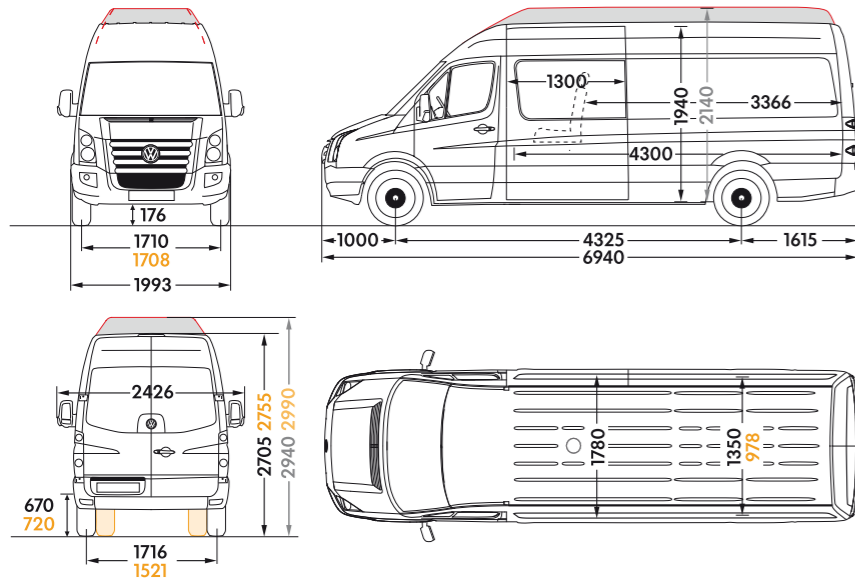

	Roof height	
	high	extra high
Wheelbase	4,325	4,325
Load compartment volume	14.0m ³ *	15.0m ³ *
Lateral sliding door width	1,300	1,300
height	1,820	1,820
Rear doors width	1,565	1,565
height	1,840	1,840
Turning circle (wall to wall)	15.6m	15.6m

Figures in orange indicate CR50 dimensions, where different.
Dimensions in mm unless otherwise indicated.

- Indicates optional roof height.
- * Dual passenger seat in rear is not excluded from volume.

CR35 / CR50 kombi long wheelbase maxi[†] high and extra high roof.

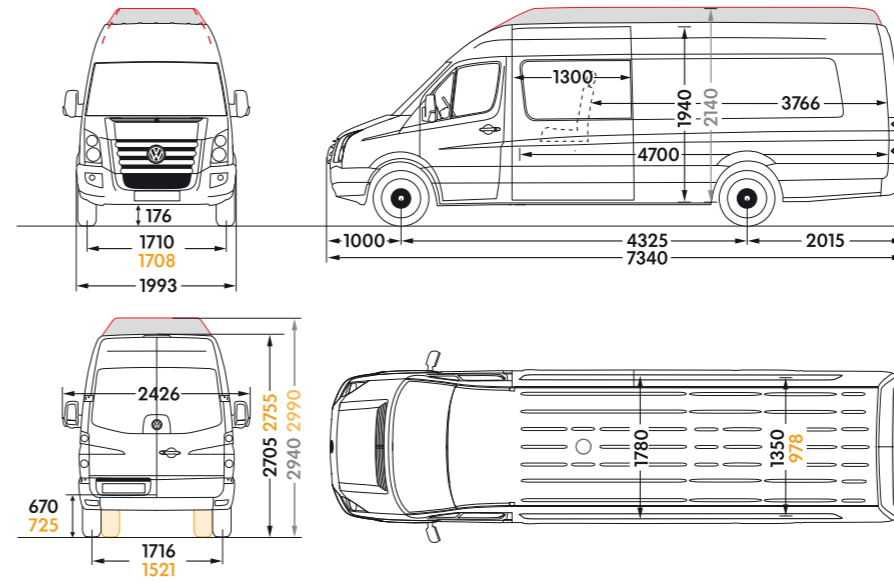

	Roof height	
	high	extra high
Wheelbase	4,325	4,325
Load compartment volume	15.5m ³ *	17m ³ *
Lateral sliding door width	1,300	1,300
height	1,820	1,820
Rear doors width	1,565	1,565
height	1,840	1,840
Turning circle (wall to wall)	15.6m	15.6m

Figures in orange indicate CR50 dimensions, where different.
Dimensions in mm unless otherwise indicated.

- Indicates optional roof height.
- * Dual passenger seat in rear is not excluded from volume.

The height measurements listed for dimensions are based on vehicles with standard specification, and may differ by approx ± 40mm depending on equipment fitted.
Dual passenger seat in rear is removable.
Please note vehicle drawings are not to scale.

Gross vehicle weight	Engine	Axle load limit front / rear	Trailer weight braked / unbraked*	Gross train weight	Unladen weight**	Payload**
Model	kg	kg	kg	kg	kg	kg
CR35 3,500	109PS BlueTDI	1,650 / 2,250	2,000 / 750	5,500	2,443	1,057
	109PS BlueTDI Shiftmatic	1,650 / 2,250	2,000 / 750	5,500	2,441	1,059
	136PS BlueTDI	1,650 / 2,250	2,000 / 750	5,500	2,443	1,057
	136PS BlueTDI Shiftmatic	1,650 / 2,250	2,000 / 750	5,500	2,441	1,059
	163PS BlueTDI	1,650 / 2,250	2,000 / 750	5,500	2,443	1,057
CR50 5,000	109PS BlueTDI	1,850 / 3,500	2,000 / 750	7,000	2,761	2,239
	109PS BlueTDI Shiftmatic	1,850 / 3,500	2,000 / 750	7,000	2,759	2,241
	136PS BlueTDI	1,850 / 3,500	2,000 / 750	7,000	2,761	2,239
	136PS BlueTDI Shiftmatic	1,850 / 3,500	2,000 / 750	7,000	2,759	2,241
	163PS BlueTDI	1,850 / 3,500	3,000 / 750	7,000	2,761	2,239

Gross vehicle weight	Engine	Axle load limit front / rear	Trailer weight braked / unbraked*	Gross train weight	Unladen weight**	Payload**
Model	kg	kg	kg	kg	kg	kg
CR35 3,500	109PS BlueTDI	1,650 / 2,250	2,000 / 750	5,500	2,504	996
	109PS BlueTDI Shiftmatic	1,650 / 2,250	2,000 / 750	5,500	2,502	998
	136PS BlueTDI	1,650 / 2,250	2,000 / 750	5,500	2,504	996
	136PS BlueTDI Shiftmatic	1,650 / 2,250	2,000 / 750	5,500	2,502	998
	163PS BlueTDI	1,650 / 2,250	2,000 / 750	5,500	2,504	996
CR50 5,000	109PS BlueTDI	1,850 / 3,500	2,000 / 750	7,000	2,814	2,186
	109PS BlueTDI Shiftmatic	1,850 / 3,500	2,000 / 750	7,000	2,812	2,188
	136PS BlueTDI	1,850 / 3,500	2,000 / 750	7,000	2,814	2,186
	136PS BlueTDI Shiftmatic	1,850 / 3,500	2,000 / 750	7,000	2,812	2,188
	163PS BlueTDI	1,850 / 3,500	3,000 / 750	7,000	2,814	2,186

Roof load limit 300kg (low roof); 150kg (high roof).
Trailer nose weight 100kg.
All data is provisional.
† Maxi = extended rear overhang.
* For 12% gradient.
** Unladen weight and payload includes approximately 90% fuel load and 75kg for driver.
Payload = gross vehicle weight - unladen weight.

Weights are for vehicles with standard specification. The addition of factory options or Volkswagen Van Centre fitted accessories may affect unladen weight and payload.

Please note: The CR35 model has a designed 'Trailer weight braked' of 2,800kg, so it is possible for an aftermarket braked towbar of up to 2,800kg to be fitted providing that the vehicle plating is also retro-uprated to a maximum of 2,800kg (and 'Gross train weight' of 6,300kg). Please contact your nearest Van Centre for details, including available axle ratio options to suit vehicle requirements.

Crafter kombi engine specifications.

	109PS BlueTDI	136PS BlueTDI	163PS BlueTDI
Mixture preparation/injection method	Common-rail direct injection		
EU exhaust emission standard	EURO V and EEV [†]		
No. of cylinders	5		
Cubic capacity, cm ³	2,461		
Output, PS at rpm	109 at 3,300	136 at 3,500	163 at 3,500
Torque, max. Nm/rpm	300/1,900-2,300	330/2,000	360/2,200
Diesel particulate filter	•	•	•
6-speed manual gearbox	•	•	•
6-speed Shiftmatic gearbox	•	•	-
Rear wheel drive	•	•	•

Electrics.

Alternator	110A		
Battery	- CR35	72Ah (380A)	
	- CR50	100Ah (450A)	

- Available
- Not available
- [†] Enhanced Environmentally Friendly Vehicle - the emission measure below the maximum limit for EURO V standards.

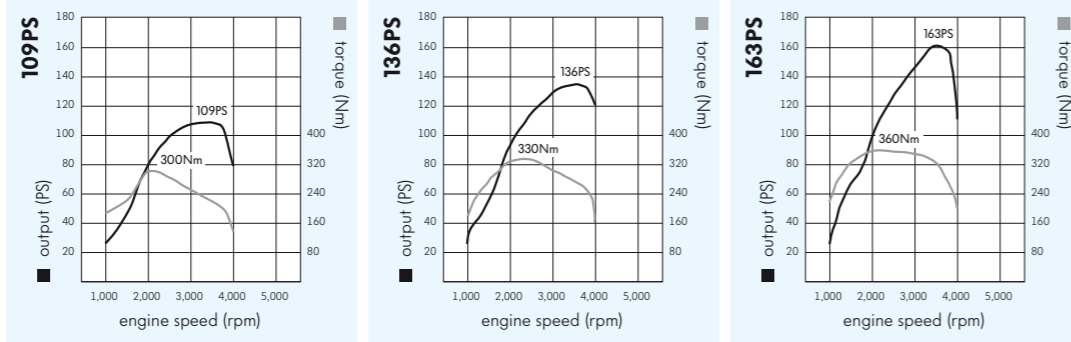

Crafter kombi fuel consumption and performance.

Model	Engine		Urban ¹ mpg (l/100km)	Extra urban ¹ mpg (l/100km)	Combined ¹ mpg (l/100km)	Top speed (where the law permits) mph
Kombi with high roof. (medium wheelbase and long wheelbase)						
CR35	109PS BlueTDI	2.5 litre	23.5 (12.0)	34.4 (8.2)	29.4 (9.6)	91
	109PS BlueTDI Shiftmatic	2.5 litre	27.4 (10.3)	33.2 (8.5)	31.0 (9.1)	89
	136PS BlueTDI	2.5 litre	23.2 (12.2)	33.6 (8.4)	28.8 (9.8)	96
	136PS BlueTDI Shiftmatic	2.5 litre	27.4 (10.3)	33.2 (8.5)	31.0 (9.1)	93
	163PS BlueTDI	2.5 litre	23.0 (12.3)	33.6 (8.4)	28.8 (9.8)	99
CR50	109PS BlueTDI	2.5 litre	TBA	TBA	TBA	56 (83)
	109PS BlueTDI Shiftmatic	2.5 litre	TBA	TBA	TBA	56 (80)
	136PS BlueTDI	2.5 litre	TBA	TBA	TBA	56 (86)
	136PS BlueTDI Shiftmatic	2.5 litre	TBA	TBA	TBA	56 (84)
	163PS BlueTDI	2.5 litre	TBA	TBA	TBA	56 (94)

Kombi with optional extra high roof. (medium wheelbase and long wheelbase)

CR35	109PS BlueTDI	2.5 litre	23.5 (12.0)	34.4 (8.2)	29.4 (9.6)	88
	109PS BlueTDI Shiftmatic	2.5 litre	27.4 (10.3)	33.2 (8.5)	31.0 (9.1)	89
	136PS BlueTDI	2.5 litre	23.2 (12.2)	33.6 (8.4)	28.8 (9.8)	91
	136PS BlueTDI Shiftmatic	2.5 litre	27.4 (10.3)	33.2 (8.5)	31.0 (9.1)	93
	163PS BlueTDI	2.5 litre	23.0 (12.3)	33.6 (8.4)	28.8 (9.8)	97
CR50	109PS BlueTDI	2.5 litre	TBA	TBA	TBA	56 (80)
	109PS BlueTDI Shiftmatic	2.5 litre	TBA	TBA	TBA	56 (78)
	136PS BlueTDI	2.5 litre	TBA	TBA	TBA	56 (83)
	136PS BlueTDI Shiftmatic	2.5 litre	TBA	TBA	TBA	56 (81)
	163PS BlueTDI	2.5 litre	TBA	TBA	TBA	56 (91)

¹ With 50% payload.

The figures listed apply to vehicles with manual gearbox, without optional extras. Figures in square brackets show top speed for vehicles without speed limiter. Figures above show vehicles fitted with standard axle ratio.

Shiftmatic.

This lightweight gearbox combines the functionality of an automatic with the characteristics of a manual.

The Shiftmatic can be operated in either manual or automatic mode. In automatic mode all gears are selected automatically by the gearbox control unit, with a kick-down function for those times where extra acceleration is needed.

In manual mode, the driver pushes the gear lever forwards to change down, or backwards to change up, giving all the benefits of a manual gearbox without the need for a manual clutch – perfect for city driving.



AdBlue®.

Driving becomes even more economical and environmentally-friendly with new AdBlue® Technology, which works in combination with an SCR catalyst and the Crafter's long gear ratios to significantly reduce fuel consumption and nitrogen oxide emissions.

All BlueTDI Crafters are equipped with AdBlue®, which fulfils the most demanding European emission standard, EEV (Enhanced Environmentally friendly Vehicle), and exceeds the Euro V emissions standard.

Stop-Start function.

The Crafter's Stop-Start function, available as an option, is activated by a switch on the instrument panel and is designed to turn off the engine automatically when it's not needed – saving fuel and cutting vehicle emissions, noise and engine wear.







The engine will stop whenever the vehicle is stationary for more than two seconds, providing the gearbox is in neutral and the clutch has been released, and will then restart automatically when the driver depresses the clutch. For safety, the system is automatically de-activated if the door or bonnet is opened or the seat belt is undone.

Paint colours and upholstery.

Solid paint.







 Candy white B4B4	 Steel blue B6B6	 Flannel grey B9B9	 Bright orange E3E3	 Indian blue F3F3
 Spanish red H9H9	 Pure grey J2J2	 Sunny yellow M9M9	 Grey white T7T7 9904	 Lime W5W5
 Sea green 5U5U	 Deep black 3902	 Black 9000	 Danish blue 9506	 Stone blue 9544

 Lambada green F9F9	 Tornado red G2G2	 Paprika red H7H7
 Surf blue 1C1C	 Spectral yellow 1X1X	 Salsa red 4Y4Y
 Friesen green 9644 ¹ X8X8 X8X8		

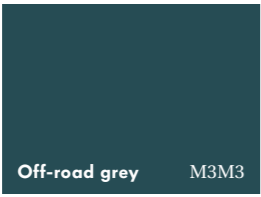
-  Available on Caddy.
-  Available on new Transporter.
-  Available on Crafter.
-  Available on Caddy at extra cost.
-  Available on new Transporter at extra cost.
-  Available on Crafter at extra cost.

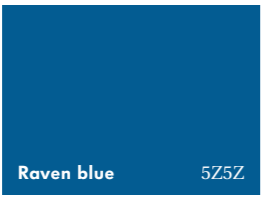

Please note: Print processes do not allow exact reproduction of the paint and upholstery colours.
¹ These colours are available at extra cost.
² Available on Caddy and Caddy Maxi Sportline.
³ Available on Caddy and Caddy Maxi Sportline at extra cost.

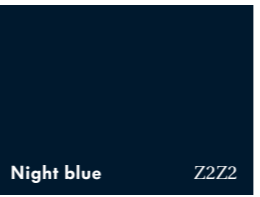
Metallic paint¹



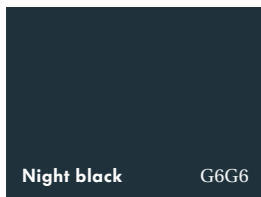
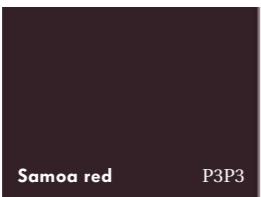
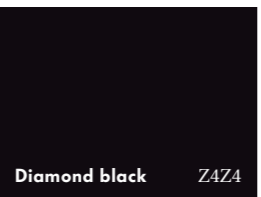

 Red spice K7K7	 Off-road grey M3M3	 Natural grey M4M4	 Shadow blue P6P6	 Sand beige P8P8
 Toffee brown 4Q4Q	 Raven blue 5Z5Z	 Reflex silver 8E8E	 Night blue Z2Z2	

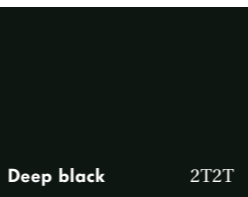
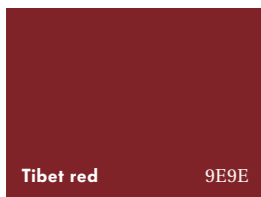
 Oxide silver Q5Q5	 Olympian blue S6S6	 Fresco green 3P3P
--	---	--

Pearl effect paint¹

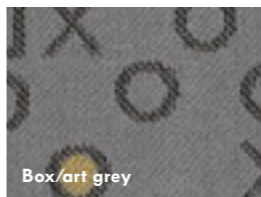
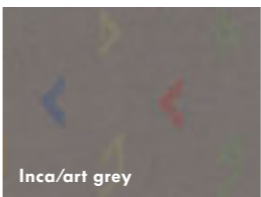
 Night black G6G6	 Samoa red P3P3	 Diamond black Z4Z4	 Mistral blue 2E2E	 Deep black 2T2T
 Tibet red 9E9E				

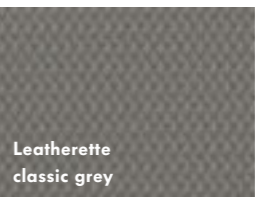
Upholstery.

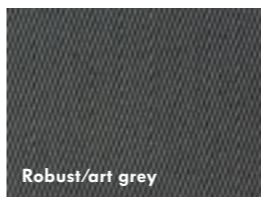
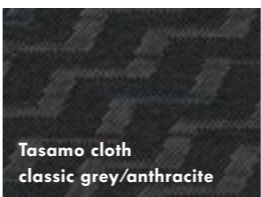
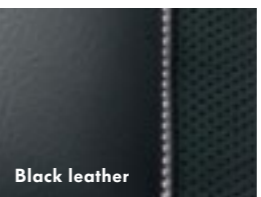
 Box/art grey CV	 Inca/art grey AN BY	 Place cloth classic grey RD	 Leatherette classic grey RD	 Rhombus/art grey leatherette MB MC
 Robust/art grey AN RD	 Tasamo cloth classic grey/anthracite RF	 Black leather		

Paint and upholstery options subject to availability.

Accessories.

Our comprehensive range of Volkswagen Commercial Vehicle accessories is constantly evolving to ensure that we can satisfy your every need.

Whether you are looking to increase the flexibility of your vehicle or opting for an aesthetic enhancement, our vast array of accessory products coupled with our dedicated network of Van Centres will help you individualise an already well appointed vehicle.

For the full range of commercial vehicle accessories visit our website www.volkswagen-vans.co.uk/accessories or pick up a commercial vehicles accessory brochure from your nearest Van Centre.

Load securing.



Van care.



Safety.



Leather.

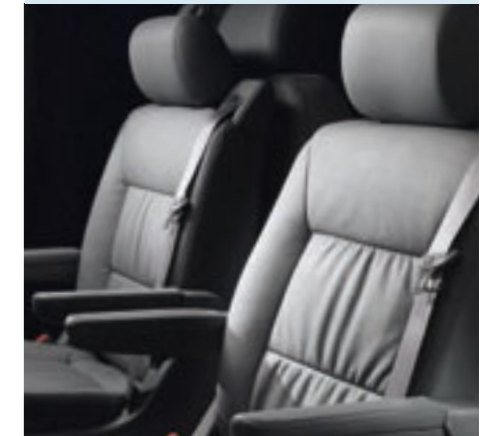

Media.



Security.

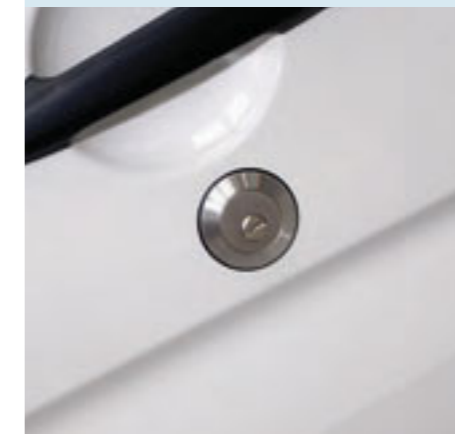

Touring.



Protection.



Towing.



Sport and Styling.



Volkswagen service for your peace of mind.



The Volkswagen warranty.

Three-year warranty*

All Crafters come with a three-year unlimited mileage warranty, which protects your vehicle against the failure of most mechanical and electrical components due to manufacturing defects. This comprises a two-year manufacturer's warranty with unlimited mileage plus a further one-year unlimited mileage Van Centre warranty.

All other Volkswagen Commercial Vehicles come with a three-year/100,000 miles warranty. This comprises a two-year manufacturer's warranty with unlimited mileage plus a further one-year/100,000 miles (whichever is soonest) Van Centre warranty. Should the mileage exceed 100,000 miles within the first two years, the manufacturer's two-year warranty will still be valid. If an additional warranty for subsequent years or higher mileage is desired, it may be purchased from an authorised Volkswagen Van Centre or Van Service Centre; however, this additional warranty must be purchased before the mileage reaches 100,000.

Three-year Paint warranty*

The paintwork of all vehicles is covered against manufacturing defects for a period of three years. Naturally, the vehicle must be cared for in compliance with the operating instructions which will be found in your owners handbook.

12-year Body Protection warranty*

The internal body sections and panels of all vehicles are covered against rusting through from the inside for 12 years. Naturally, the vehicle must be cared for in compliance with the operating instructions.

Service intervals for Diesel Engines**

The LongLife Service regime is so called because there are no set intervals. The intervals between services will vary depending on how you drive your vehicle and the conditions of use. There is however maximum time/distance parameters set and if the service light has not already come on it will do so when either the maximum mileage or time limit is met.

The maximum mileage/time parameters vary by model, for more detailed information on LongLife Service regimes and their suitability for your requirements please contact your local Van Centre.

If you would like a more traditional service regime the vehicle can be adapted by your authorised Volkswagen Van Centre or Van Service Centre to the Time/Distance regime. This can be done at the point of vehicle sale or when an inspection service is carried out. An oil change is required at every 10,000 miles for Caddys and new Transporters and 12,500 for Crafters on the Time/Distance regime.

Volkswagen Commercial Vehicle Finance†

Volkswagen Commercial Vehicle Finance offers a dedicated service to meet the needs of both the business user and the private motorist. Your local Van Centre can help you choose the right type of finance package to meet your specific requirements. Please ask for details.

† Volkswagen Commercial Vehicle Finance is a trading name of Volkswagen Financial Services (UK) Limited. Subject to status. Finance available to over 18s only. Indemnities may be required.



Volkswagen Commercial Vehicle Insurance.

We want you to start enjoying your new van from day one and thanks to the complimentary seven day cover from Volkswagen Commercial Vehicle Insurance, you can. Call free on **0800 316 7896** (lines are open Monday to Friday 8am – 9pm and Saturday 9am – 5pm), provide a few details and a cover note will be sent to your Van Centre. They will then tax your vehicle and you can drive it away. Visit insurewithvwc.co.uk for details of the full range of insurance products available. Here you can also get a quote for your annual van insurance and buy it online too. All of our insurance products are designed to ease the pain of making a claim.

Volkswagen Commercial Vehicle Insurance is a trading name of Volkswagen Insurance Service (Great Britain) Limited, an appointed representative of Volkswagen Financial Services (UK) Limited, Brunswick Court, Yeomans Drive, Blakelands, Milton Keynes MK14 5LR. Registered in England number 2835230. Volkswagen Commercial Vehicle Insurance is sold, underwritten and administered by Allianz Insurance plc registered in England number 84638. Registered office 57 Ladymead, Guildford, Surrey GU1 1DB. Volkswagen Financial Services (UK) Limited and Allianz Insurance plc are authorised and regulated by the Financial Services Authority. Volkswagen Financial Services (UK) Limited and Allianz Insurance plc are not part of the same corporate group.

* Full details of Volkswagen warranties are available from your authorised Volkswagen Van Centre or Van Service Centre.

** All mileages are approximate as the system uses kilometres as the distance measure. Please consult your authorised Volkswagen Van Centre or Van Service Centre for full details.

Please note: Some of the vehicles shown are fitted with optional equipment at extra charge. All data given and specifications are in accordance with information available at the time of going to print and are subject to change without notice. Vehicles not in current UK stock and customer order vehicles may take a number of weeks for delivery. Certain combinations of vehicle specifications and factory fitted extras are not compatible and therefore all orders received are subject to confirmation. Models, factory fitted options and paint and upholstery options subject to availability. Please check details and availability with an authorised Volkswagen Van Centre at the time of ordering. Please check details and availability with an authorised Volkswagen Van Centre at the time of ordering. The brand name Caddy is used with the kind approval of 'Caddie S.A., France'.

Volkswagen Original Parts®.

When you fit replacement parts to your vehicle, you need to know that they'll stand the test of time. Volkswagen Original Parts® are constructed to the highest standards, are cheaper than you might think and are widely available from Volkswagen Group's massive national distribution centre.

Options and accessories.

We know that no two businesses are the same. To this end, we have developed an extensive range of factory fitted, as well as Van Centre fitted accessories, so that your van can be enhanced with your own requirements in mind.

Volkswagen Assured Used Commercial Vehicles.

An increasing number of Volkswagen Van Centres are able to offer total peace of mind when purchasing a used van. You can rest in the confidence that every Volkswagen Assured Used Commercial Vehicle has been subjected to a comprehensive range of specialist checks that make them as safe a choice as a new Volkswagen van.

Volkswagen Van Rental.

Many Volkswagen Van Centres offer a cost-effective van rental service. It comes with the assurance that every van is late model, low mileage and presented in a high quality condition that reflects your business operation. Long-term business rental is also available. For more information on Volkswagen Van Rental, call **0844 558 1588**.

Volkswagen Roadside Assistance.

Every new Volkswagen purchased benefits from an unlimited mileage, comprehensive recovery and assistance package across the UK and Europe for a full three years, operating 24 hours a day, 365 days a year. Fully trained technicians are able to diagnose and repair most problems at the roadside, using Volkswagen equipment and parts. For more information ask your nearest Van Centre for a Volkswagen Roadside Assistance handbook.

Glossary.

ABS Anti-lock Braking System.

It can be very challenging to stop a van quickly on a slippery road. ABS helps take a lot of the effort and stress out of a situation. In fact, even an average driver can stop more effectively with ABS than a professional driver without.

The theory is simple, a wheel that's skidding has less traction than a wheel that is not. For example, if you try to pull away too quickly on ice your wheels spin, meaning no traction. Simply, ABS prevents the wheels from skidding whilst you slow down, which means you slow faster and are able to steer while you come to a stop.

EDL Electronic Differential Lock.

Electronic Differential Lock uses the ABS sensors at driven wheels to determine if one of the wheels is spinning faster than the others. It uses the ABS system to momentarily apply braking to balance out the traction to the driven wheels. Front wheel drive vehicles typically have the most recognisable feel, as they make the typical ABS type pulsating sound when activated during wheel spin.

ESP Electronic Stabilisation Programme.

When the vehicle is driving in situations close to its limit ESP makes it easier to control, providing greater directional stability. By applying the brakes on individual wheels it generates forces that help to keep the vehicle moving in the right direction. The system is permanently active and utilises the ABS, EBD, EDL and TCS safety systems. However, the system cannot override the physical limits of the vehicle. If the driver pushes the vehicle beyond its limits ESP will not prevent an accident. On Crafter models, the ESP sensor takes into account any load on board and adjusts its response accordingly.

ARP Active Rollover Protection.

As part of the ESP system, ARP recognises an impending rollover and rapidly applies braking to selective wheels to resist the occurrence of rollover. Especially useful on a vehicle with a high centre of gravity such as a van. ARP detects excessive lateral force, for example driving too fast into a corner, which may result in a rollover.

TCS Traction Control System.

Traction control helps limit tyre slip on slippery surfaces while accelerating, thus helping the driver have greater control. Using sensors at each wheel, the system recognises when traction has been lost and it momentarily applies braking to that wheel to regain the traction.

Traction control does not have the ability to increase traction; it just attempts to prevent a vehicle's wheels from spinning. In some vehicles, TCS is also known as ASR.

EBA Electronic Brake Assist.

The Electronic Brake Assist system helps to shorten stopping distances, especially when fully laden. In an emergency when full brake pressure is required, a sensor recognises this and uses a hydraulic booster to aid the driver.

EBD Electronic Brakeforce Distribution.

EBD helps prevent the rear-end from breaking away under heavy braking by ensuring maximum braking performance at both the front and rear wheels. Brake 'fading', as a result of overheating, is also counteracted.

DPF Diesel Particulate Filter.

A diesel particulate filter is a system for removing particulates from diesel exhausts and is a major step forward in the reduction of particulate contaminants in the environment.

EBC Engine Braking Control.

This system prevents the driven wheels from locking due to the engine braking effect when the accelerator pedal is released suddenly or when the vehicle is braked with a gear engaged.

BlueMotion Technology.

BlueMotion Technology aims to reduce the impact of our vehicles on the environment by adding refinements to improve fuel consumption and cut CO₂ emissions.

Passive safety.

Passive safety refers measures that help protect the occupants against injury or help reduce injury severity in the event of an accident. Passive safety measures include the safety belt system, the airbags*, the rigid occupant cell and the crumple zones at the front of the vehicle. Safety features built-in to the body, front and rear, help dissipate most of the impact energy. All help provide excellent all-around protection.

SCR Catalyst.

Selective Catalytic Reduction is a means of converting nitrogen oxides, also referred to as NO_x, into nitrogen N₂ and water H₂O. AdBlue® is injected into the stream of exhaust gas and the chemical reaction takes place within the SCR Catalyst.

Dedicated Van Centre network.

Our network of Van Centres is spread throughout the UK, and forms the backbone of everything we do for you. Week in, week out, our Van Centres provide vital technical support and practical backup for everything that relates to Volkswagen vans. This reservoir of knowledge and array of technical ability is there for you when you need it.

We're constantly improving and extending our range of services, and improving opening hours to meet

your needs. After all, you need your vehicle serviced at the most convenient time, and we understand that down time equals lost income.

And don't forget, having read through this brochure, if you still aren't sure which vehicle is the right one, then your nearest Van Centre staff will be pleased to help.

www.vwvancentres.co.uk

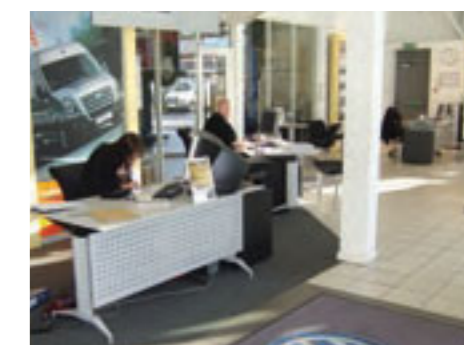

Panel vans and kombis

January 2010

This brochure supersedes all previous publications.
CVW227PVAN

www.volkswagen-vans.co.uk