

The Passat and Passat Estate



Sheer pleasure.



Model shown is Highline with optional pearl effect paint.

Design

The Passat is breathtaking from the minute you set your eyes on it. The exterior boasts power and charisma, with the wide track width and low-set front end all producing a striking appearance, giving a hint of the driving pleasure to come. The gleaming chrome-plated radiator grille surround is a real design highlight, reinforcing the story. Add to that the confident shape of both the Saloon and Estate models and the story of aerodynamic design and sports performance is complete.

It's not just aesthetic appeal where the Passat excels, however. Innovative design is also paramount. Right from initial development, many features were designed to contribute to safety, such as the V-shaped bonnet, providing integral pedestrian protection. And the greatest attention was given to the smallest detail, resulting in such special touches as the elegantly shaped body-coloured door handles and door mirrors with integrated LED indicators and the minimal gaps between panels. With the galvanised body providing a 12-year warranty against corrosion, it's all testimony to Volkswagen's legendary build quality and precision approach.



Practical: Four load lashing points in the luggage compartment help you transport items safely and securely.



The greatest attention was given to the smallest detail, resulting in such special touches as the elegantly shaped **body-coloured door mirrors** with integrated LED indicators.



The stylish and elegant design of the Passat. Highline Plus models have distinctive **chrome-plated radiator grille surround, roundel surround and louvres** to create an individual look.

Model shown is Highline Plus.



Flexible: the rear seat and backrest of the Passat Estate can be folded asymmetrically, extending the loading space to a length of up to 1,956 mm.



The sleek contoured **body-coloured door handles** complement the Passat's strong lines and dynamic design.

Harmony.



Model shown is Highline with optional front fog lights and pearl effect paint.

Interior

The interior of the Passat has been carefully designed to ensure you feel at home as soon as you sit behind the wheel. Modern trims and beautiful decor, made from the finest quality materials, interplay perfectly, suffusing the interior with a feeling of luxury and calm. And it's not simply a question of aesthetics. Ergonomic design actually makes driving easier. For a start, all the controls are arranged so that handling becomes intuitive, take for example on R line, Highline, Highline Plus and R36 models the leather trimmed three-spoke multifunction steering wheel allows controls of the multifunction computer, audio system and optional telephone preparation. The white lit instrument panel is within your immediate field of vision, giving you all the information you need while driving – from the speed of the vehicle to the temperature outside. The electronic parking brake with auto hold function – which automatically holds the vehicle when you come to a stop on a hill and then releases as you pull away, press and drive ignition and front electric windows are also positioned for ease of use, and operate literally at the touch of a button.

The same degree of ease and comfort can also be found in the seats of the Passat. Easily adjustable and fitted with head restraints you're guaranteed maximum support whichever seat you choose. In fact, the Highline and Highline Plus' 6-way electrically-adjustable driver's seat is surpassed only by the 12-way electrically-adjustable seat on R36 models. Both offer adjustments for lumbar support and seat back angle, enabling you to sit back and relax, enjoying the most ergonomically beneficial position for your spine.

Generous interior space is another contributory factor to overall comfort, with the transversely mounted engine providing more room than ever before for passengers and luggage, and giving all occupants significantly more legroom. Should you need to transport bulky objects or luggage, the Passat Saloon offers an impressive capacity of up to 1,001 litres* (977 litres* on Passat Saloon R36 models), while Estate models can hold up to a huge 1,641 litres* (1,626 litres* on Passat Estate R36 models). In addition, a novel stowage concept provides extra space in the vehicle interior, enabling you to store maps, sunglasses and CDs in the doors, front seat centre armrest on Highline and above, overhead console or centre console.

* Measured in accordance with ISO 3832. VDA measuring method using 200 x 100 x 50 mm blocks and with rear seat backrest upright.



Thanks to the press and drive key, starting has never been simpler.



The electronic parking brake with auto hold function secures the vehicle easily and reliably at the touch of a button. It releases automatically as soon as you pull away, preventing your Passat from rolling back when hill starting.



The Highline's multifunction steering wheel enables you to select numerous functions without taking your hands from the wheel while driving. The clearly arranged instrument panel and controls are also located directly within your field of vision. Multifunction steering wheels are standard on R Line, Highline, Highline Plus and R36 models.



Elegant design using refined materials combine to create a luxurious interior.



The RCD 310 radio/MP3 compatible CD player with eight speakers and AUX-in socket for connection to an external multimedia source (e.g. iPod and MP3 player) will ensure enjoyment on any journey.



The doors can be locked or unlocked in one simple operation and the front electric windows have a handy one-touch opening and closing function for ease of use.



Exhilarating.

Model shown is Highline 2.0 litre TDI with optional pearl effect paint.



Interior shown is S.

The S and S BlueMotion Technology

More comfort, more safety and, above all, more driving pleasure. That's what you can expect from the Passat S, where a whole host of standard fittings provides everything you would expect – and more – from an extraordinary car. The front windows and heated door mirrors are electrically operated, the boot lid on the Saloon and tailgate on the Estate opens automatically with remote operation, and the press and drive key allows you to start the engine simply by pushing the key, and the four-spoke steering wheel individually adjusts to your optimum driving position. And that's just for starters. Also fitted as standard is an RCD 310 radio/MP3 compatible CD player with eight speakers and AUX-in socket for connection to an external multimedia source (e.g. iPod and MP3 player), 'Climatic' semi-automatic air conditioning, electronic parking brake with auto hold function and alarm with interior protection and remote central locking.

Driving the Passat S is an even more enjoyable experience. One reason is certainly the 16 inch 'Milwaukee' alloy wheels with 215/55 R16 tyres, guaranteeing dynamic handling and appearance. Another is the eye-catching interior, with its 'Dark Rhodium' decorative inlays and whole array of practical stowage trays and storage compartments positioned in the doors and roof console. To ensure driving is not just pleasurable but also worry-free, the Passat S benefits from many safety features, such as WOKS (whiplash-optimised head restraints) in the front, front airbags with front passenger airbag deactivation, front seat side impact airbags, curtain airbags, and an Electronic Stabilisation Programme (ESP). As you can see, Volkswagen have thought of everything – all you have to do is concentrate on enjoying the drive.

* Please see the Engines section for fuel consumption and CO₂ emissions figures.

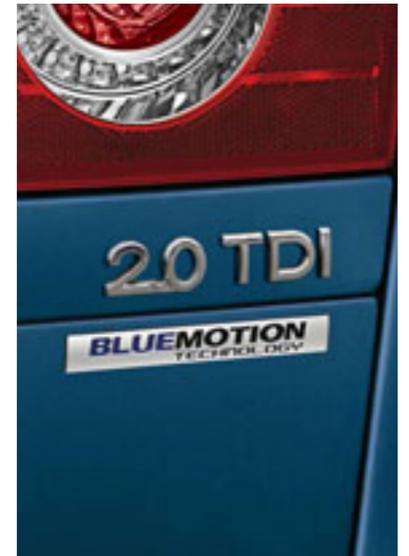

Specify the Passat S with 'BlueMotion Technology' and you'll benefit from an improved fuel consumption of around 10% along with an impressive CO₂ emission figure* from just 118 g/km. For more information on BlueMotion Technologies, please see Environment section.



The RCD 310 radio/MP3 compatible CD player with eight speakers and AUX-in socket for connection to an external multimedia source (e.g. iPod and MP3 player) will ensure enjoyment on any journey.



16 inch 'Milwaukee' 7J x 16 alloy wheels are both sporty and stylish.

The BlueMotion

The Passat BlueMotion builds over the already well equipped Passat S and, in addition, offers impressive environmental credentials by intelligently refining existing technology. Dynamic lines reduce the vehicle's air resistance and, combined with engineering refinements, low rolling resistance tyres, lowered suspension and battery regeneration (recuperation – energy recovery during braking) help produce exceptional economy. A Start/Stop function is also fitted in place of the auto hold function – this automatically stops the engine when the vehicle is stationary and restarts it when you pull away, saving fuel and reducing emissions. A combination of all these refinements delivers a package that offers excellent economy up to 64.2 mpg over the Combined fuel cycle*, and the 1.6 litre TDI 105 PS engine, with DPF (Diesel Particulate Filter) fitted as standard, ensures CO₂ emissions are from an impressively low 114 g/km.

The Passat BlueMotion adds a higher specification which is evident from its stylish exterior, with 16 inch 'Sarena' alloy wheels with 205/55 R16 low rolling resistance tyres, body-coloured front and rear bumpers with chrome side bump strips, rear bumper strips and body-coloured side sills, while unique 'BlueMotion' badging completes the look. Internally, the BlueMotion benefits from a luxurious leather trimmed three-spoke steering wheel and for added convenience, there is also cruise control and a multifunction computer (Highline) which includes visual gear change recommendations for optimum fuel consumption.

* Please see the Engines section for fuel consumption and CO₂ emissions figures.



The multifunction computer (Highline) includes visual gear change recommendation for optimum fuel consumption. Standard on BlueMotion models.



BlueMotion models feature 16 inch 'Sarena' 7J x 16 alloy wheels with low rolling resistance tyres, lowered suspension and body-coloured side sills.



Interior shown is BlueMotion.

Refinement.



Model shown is R Line with optional metallic paint.

The R Line

If a sleek, sporty look with a whole host of creature comforts is what you want from your Passat, then the R Line will exceed your every expectation. While still comprising all of the specification, luxury and practicality of the Passat S, the R Line builds an even more impressive look, both inside and out.

Five-spoke 17 inch 'Monte Carlo' alloy wheels adorn the exterior, along with body-coloured front and rear bumpers, and additional side sills which give the car a real sporting essence. Its distinctive exterior is completed by the front grille surround and the double louvres finished in elegant matt chrome.

Inside, the R Line is a quiet, comfortable and luxurious interior designed to make each journey smooth and relaxing. The leather trimmed three-spoke steering wheel with chrome insert features handy multifunction buttons to control the radio and cruise control, so everything you need is available at the touch of a button. You can even control the multifunction computer (Highline), which offers useful information about your journey such as range, fuel consumption and outside temperature, all without having to take your eyes off the road. Cruise control allows you to select a constant speed over 19 mph, helping you to relax on longer journeys, while the seat height and lumbar adjustment on both front seats enable you to find the optimal position to remain comfortable until you reach your destination. A flat tyre indicator is also included, which will alert you to any loss in tyre pressure via a warning symbol displayed in the dashboard, while the front centre armrest with storage box and a handy 12V socket in the rear adds an extra touch of comfort.



17 inch 'Monte Carlo' 7½J x 17 alloy wheels create a sporty yet elegant look to the Passat R Line.



Interior shown is R Line.



The Climatic semi-automatic air conditioning system also controls the driver's and front passenger's heated front seats. With three individual temperature settings to choose from, you can be sure of a comfortable journey every time.



17 inch 'Macau' 7J x 17 alloy wheels create a classic and stylish look to the exterior of the Passat Highline and Highline BlueMotion Technology models.

The Highline and Highline BlueMotion Technology

Whether you're taking a long or short trip, driving the Passat Highline is an absolute joy because, quite simply, everything has been included to make life as relaxing as possible. Easily distinguished by its body-coloured front bumper strips, chrome-plated side bump strips and rear bumper strips, 'chrome satin' side window surrounds and 17 inch 'Macau' alloy wheels with 235/45 R17 tyres, this exceptional car offers a phenomenal level of specification.

Inside, the electrically-operated 6-way adjustable driver's seat and manually adjustable front passenger seat guarantee the best possible seating posture at all times, while heated front seats and a front centre armrest add an extra touch of luxury. Sumptuous 'Vienna' leather* upholstery is complemented by a leather trimmed gear knob, carpet mats front and rear, and matt chrome decorative inserts in the dash and centre console with black or grey upholstery, (or brushed stainless steel decorative inserts when you choose latte or cornsilk beige leather). To ensure stress-free driving, there's a leather trimmed three-spoke multifunction steering wheel and multifunction computer (Highline), providing essential information about your journey, and, to help you relax on longer journeys, cruise control will automatically maintain your desired speed above 19 mph without you having to touch the accelerator pedal.

Interior comfort is further assured by electric rear windows and an RCD 310 radio/MP3 compatible CD player with eight speakers and AUX-in socket for connection to an external multimedia source (e.g. iPod and MP3 player). With a load-through provision to help you transport bulky items and even a full size alloy spare wheel, you can be sure virtually no other car offers this level of versatility, comfort and style.

The Highline is also available in BlueMotion Technology guise, offering increased fuel economy and reduced CO₂ emissions, which reduce the impact on the environment and your wallet. For more information on BlueMotion Technologies, please see Environment section.



Interior shown is **Highline** with front comfort seats upholstered in grey 'Vienna' leather* and an optional RCD 510 touch-screen radio/MP3 compatible 6 CD autochanger.

* Please note that some parts of leather interior will contain artificial leather.



Interior shown is **Highline Plus** with front comfort seats upholstered in cornsilk beige 'Vienna' leather*.

* Please note that some parts of leather interior will contain artificial leather.

The Highline Plus and Highline Plus BlueMotion Technology

Externally, the chrome-plated radiator grille surround and louvres distinguish the Passat Highline Plus from the already stylish exterior of the Passat Highline. Inside, the Highline Plus shares the same high specification as the Highline including 'Vienna' leather* upholstery, electrically-operated 6-way adjustable driver's seat, leather trimmed three-spoke multifunction steering wheel, multifunction computer (Highline) and cruise control to name but a few.

To make life just that little bit easier and to ensure you reach your destination safely and easily, the Passat Highline Plus features a navigation/radio system and Bluetooth preparation as standard. The RNS 310 touch-screen navigation/radio system, has an intuitive 5 inch colour touch-screen, MP3 compatible CD player and eight speakers. As well as featuring the latest in processor technology, resulting in quick route calculations using all but the last two digits of a UK postcode, this sophisticated system features an SD (Secure Digital) card reader that also allows playback of audio files. Completing the multimedia experience is the ability to connect an external multimedia device (e.g. iPod and MP3 player) via the AUX-in socket.

The Bluetooth telephone preparation system with detachable 2.8 inch touch-screen allows you to make and receive telephone calls without having to take your eyes off the road. It acts as an interface of the mobile phone menu connected to it and is compatible with most Bluetooth enabled phones†, including iPod and Blackberry. It automatically synchronises with your mobile's phone book allowing you to select a name and call. It also features audio volume reduction when activated and message alert function, as well as displaying icons showing signal strength, battery strength, Bluetooth on/off and connectivity amongst others.

With everything included for your total driving pleasure and so much to offer, there is only one way to appreciate the exceptional Highline Plus. Experience it for yourself.

Offering increased fuel economy and reduced CO₂ emissions, the Highline Plus is also available with BlueMotion Technologies. These innovative technologies help reduce the impact on the environment and can help save you money. For more information on BlueMotion Technologies, please see Environment section.



The Bluetooth telephone preparation system with detachable 2.8 inch touch-screen acts as an interface of the mobile phone menu connected to it. Compatible with most Bluetooth enabled phones†, it synchronises with your mobile's phone book allowing you to select a name and call.

† Please contact your retailer for phone compatibility.



Highline Plus models benefit from an RNS 310 touch-screen navigation/radio system including 5 inch colour screen, SD card reader and AUX-in socket for connection to an external multimedia source.



0-62 in just 5.6 seconds.

Model shown is R36 with optional pearl effect paint.



Interior shown is R36 with optional 'Engine spin' decorative inserts.

The R36

Every aspect of the R36's luxurious interior has been modelled to meet the highest expectations. Which means you'll find a level of interior specification that is second to none, including front sports seats with 'R36' logo and electric 12-way adjustment including memory for the driver, offering a perfect lateral fit and enough settings to ensure a seating position tailor-made to your personal measurements. Also included are heated front and outer rear seats, cruise control, front and rear parking sensors, heated windscreen washer jets, electronic tyre pressure monitoring system and multifunction computer (Highline).

In the cockpit, ergonomic design ensures controls that are clearly arranged and readily to hand, enabling you to achieve maximum performance with the greatest of ease. The three-spoke multifunction leather trimmed steering wheel with 'R36' logo and paddle shift, ensures maximum grip and comfort, while the RNS 310 touch-screen navigation/radio system including dash-mounted MP3 compatible CD player with eight speakers, 5 inch colour screen and AUX-in socket for connection to an external multimedia source (e.g. iPod and MP3 player) and 2Zone electronic climate control help promote driving pleasure and relaxation. The Bluetooth telephone preparation system with detachable 2.8 inch touch-screen synchronises with your mobile's phone book allowing you to select a name and call. It also features audio volume reduction when activated as well as a message alert system. Dark brushed aluminium decorative inserts on the instruments and centre console continues the sporting detail, while aluminium-look pedals featuring the 'R' logo, white illuminated instrument panel and door sill strips in stainless steel with 'R36' logo further enhance the uniquely designed interior.

Visually speaking, the Passat R36 is as near to perfection as you can get. Inspired by the world of motorsport, the R36 exhibits powerful proportions, dynamic design and sleek, aerodynamic styling. The 'R36' logo on the chrome-plated radiator grille, roundel surround and louvres, front air intakes and wheel arch extensions, Bi-Xenon headlights, front spoiler, rear boot spoiler on Saloon models and an extended roof spoiler on Estate models create a powerful road presence.

For those who love the thrill of engine power, the R36 will get your pulse racing like never before. A light touch of the accelerator pedal is all that's needed to take the Passat R36 from 0 - 62 mph in just 5.6 seconds (5.8 seconds for Estate models). It's all due to the powerful 3.6 litre FSI V6 engine, channelling drive via a six speed Direct Shift Gearbox (DSG) and producing a phenomenal 300 PS and 350 Nm of torque. The sophisticated 4MOTION four wheel drive system diverts every last Nm of torque to the wheel that needs it most, ensuring greater traction and impressive handling. Combined with sports suspension lowered by 25 mm, 18 inch 'Omanyt' alloys, front and rear disc brakes (ventilated at the front) and a dynamic bodyshape, it produces a level of performance that's nothing short of mind-blowing. All together it adds up to one undisputed fact - the R36 is the fastest Passat on the road today. Isn't it time you discovered the ultimate adrenaline rush? Sit in the R36 and you'll see life from a different perspective, where only the best is good enough. Would you expect anything less?



18 inch 'Omanyt' alloy wheels ensure maximum grip, and colour co-ordinated blue brake calipers enhance the sporty appearance.



12-way electrically adjustable sports seats, featuring the 'R36' logo woven into the fabric, offer excellent lateral support and provide total comfort during any journey.

To help reduce the impact on our environment, not only have we come up with a solution, we've designed many.

BlueMotion Technologies is our contribution to sustainable motoring. This means we offer optimum solutions for every demand, which make driving more fuel efficient and cleaner. From the low consumption, low emission diesel or petrol engines fitted to BlueMotion Technology models, to the ultra-efficient BlueMotion, BlueMotion Technologies are less harmful to our environment and your wallet, without having to give up everyday practicality and comfort.



A multifunction computer (Highline) with visual gear change recommendation for optimum fuel consumption – indicates when you should change gears to drive more economically.

Interior shown is Passat BlueMotion.



The BlueMotion Technology badge at the rear. A short message to the people driving behind you that thrift and the finer things in life are not mutually exclusive.



The BlueMotion and BlueMotion Technology Passats, available with 1.6 litre TDI 105 PS or 2.0 litre TDI 140 PS engines, offer the same refinement and comfort as the standard Passat equivalents, but with added environmental credentials. They all meet the proposed EURO 5 emissions standard, have a Diesel Particulate Filter (DPF) and are packed full of technologies to save valuable fuel and have a smaller impact on our environment. Technologies such as the Start/Stop function which saves fuel when the vehicle is stationary, just put the handbrake on, the gearbox in neutral and the engine turns itself off. Put it back into gear and the engine restarts immediately and automatically, reducing consumption and CO₂ emissions. When the multifunction computer (Highline) displays the Start/Stop symbol, you know it is active. It will also display visual gear change recommendations, advising the best time to change gear for optimum fuel consumption. All BlueMotion and BlueMotion Technology models are also fitted with a battery regeneration (recuperation) system, meaning that energy is recovered from the braking process and used to charge the battery, rather than using fuel for this process. Also fitted are low rolling resistance tyres which aid efficiency and help further reduce CO₂ emissions.

Specify a Passat BlueMotion and not only do you get all the benefits and technologies fitted to the BlueMotion Technology models, but you also get a unique aerodynamic styling pack comprising body-coloured front and rear bumpers, body-coloured side sills and lowered suspension. The result is a reduction in the vehicle's air resistance, which not only significantly improves fuel efficiency and improves roadholding, but looks great too.



Heart-stopping.

Model shown is Highline with optional metallic paint.



Volkswagen's technologically advanced TSI engines combine excellent driveability with impressive fuel economy.

Engines

Every journey is a special experience in the Passat, thanks to Volkswagen's superb range of economical, high-torque petrol and diesel engines, all designed to make driving pure pleasure. The three petrol variants benefit from direct injection technology, where the fuel is injected into the combustion chamber under high pressure, resulting in impressive performance even at low revs. The first variant is a powerful four cylinder 1.4 litre TSI engine developing 122 PS which utilises a sophisticated turbocharger, resulting in impressive output with a smaller engine size. This engine can reach 126 mph (124 mph[†]), where the law permits, and is capable of achieving a fuel consumption figure of 42.2 mpg (41.5 mpg[†]) on the Combined fuel cycle*. The second engine available for the Passat is a 1.8 litre engine, again incorporating TSI technology developing a healthy 160 PS. When specified with the six speed manual gearbox, it can accelerate the Passat to 62 mph in 8.6 seconds (8.8 seconds[†]), yet is still capable of 38.2 mpg (37.7 mpg[†]) on the Combined fuel cycle*. You could also opt for Volkswagen's innovative seven speed DSG gearbox, which combines the sportiness of a manual with the comfort of an automatic, characterised by its smooth gearshifts with no traction interruption. Finally, for the ultimate experience, the 3.6 litre FSI V6 4MOTION 300 PS engine, fitted exclusively to the R36, is sure to get your pulse racing as it accelerates from 0 - 62 mph in just 5.6 seconds (5.8 seconds[†]) on its way to a top speed of 155 mph (restricted), where the law permits.

The four diesel variants are particularly sophisticated, mainly in terms of flexibility and fuel economy. Featuring the latest common rail technology, these engines not only ensure excellent performance and fuel consumption but are also incredibly quiet. First is the four cylinder 1.6 litre TDI engine with a five speed gearbox. This engine, unique to S BlueMotion Technology and BlueMotion models, is capable of a top speed of 120 mph (118 mph[†]) where the law permits, and in its most frugal form produces a mere 114 g/km of CO₂ yet can still achieve 64.2 mpg on the Combined fuel cycle* – a benefit that will make your next journey even more pleasurable.

Second is the four cylinder 2.0 litre TDI engine with a five speed gearbox, developing 110 PS and 250 Nm of torque from just 1,500 rpm. This engine is capable of a top speed of 119 mph (118 mph[†]) where the law permits, produces a mere 143 g/km (146 g/km[†]) of CO₂ yet can still achieve 51.4 mpg (50.4 mpg[†]) on the Combined fuel cycle*.

The third diesel option, the powerful 2.0 litre TDI 140 PS engine, is available with either a six speed manual gearbox or with Volkswagen's revolutionary six speed automatic DSG gearbox. With the manual gearbox, this engine can deliver 320 Nm from just 1,750 rpm while returning a miserly 50.4 mpg (49.6 mpg[†]) on the Combined fuel cycle*. This engine is also available in BlueMotion Technology guise, which helps this engine to achieve an impressive 60.1 mpg (58.9 mpg[†]) on the Combined fuel cycle*, while emitting just 124 g/km (127 g/km[†]) of CO₂.

Finally, the equally impressive 2.0 litre TDI 170 PS can accelerate the Passat from 0 - 62 mph in just 8.6 seconds (8.8 seconds[†]) yet is capable of returning an impressive fuel consumption figure of 50.4 mpg (49.6 mpg[†]) on the Combined fuel cycle* – creating a fine balance of performance and efficiency. It is no slouch either, with a top speed of 139 mph (137 mph[†]) where the law permits.

As part of Volkswagen's continued desire to satisfy European emissions legislation, all Passat diesel engines are now fitted with a Diesel Particulate Filter (DPF) as standard. This is part of the exhaust system responsible for cleaning the exhaust gases before they enter the atmosphere. In addition to converting the harmful exhaust gases in the same way as a conventional catalytic converter, the DPF uses advanced technology to reduce the emission of black smoke and soot. It filters the exhaust gases and particles before they leave the vehicle exhaust system, resulting in a cleaner environment and less pollution entering the atmosphere.

Please note, driving conditions within inner-cities and the Channel Islands may not provide optimum conditions for the use of DPF technology. Therefore, it is advised that you consider this before ordering a vehicle with DPF.

* Please see the individual specifications in this section for fuel consumption and CO₂ emissions figures.

† Passat Estate figures.



The DSG gearbox offers a genuine alternative to a manual gearbox because it is able to change gear faster than a manual gearbox and more smoothly than a conventional automatic.

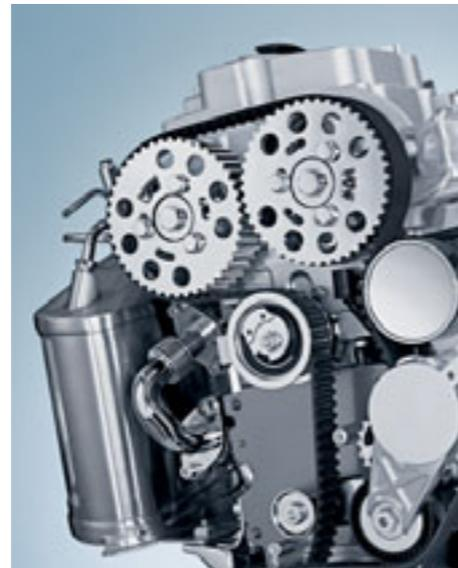

Diesel engines with the latest technology deliver outstanding performance with exceptionally low fuel consumption.

S, R Line – 1.4 litre TSI 122 PS Technical specification

		Saloon		Estate	
		Manual	Automatic	Manual	Automatic
Engine	Engine type	Four cylinder petrol		Four cylinder petrol	
	Cubic capacity, ltrs/cc	1.4/1390		1.4/1390	
	Max. output, PS ⁽⁰¹⁾ /kW	122/90		122/90	
	at rpm	5000		5000	
	Max. torque, lbs.ft./Nm	148/200		148/200	
	at rpm	1500		1500	
	Gearbox	6 spd		6 spd	
Weights, kgs	Unladen weight ⁽⁰²⁾	1463		1504	
	Gross vehicle weight	2000		2080	
	Payload ⁽⁰²⁾	612		651	
	Axle load limit: Front Rear	1050 1000		1050 1080	
Trailer load limits, kgs ⁽⁰³⁾	Braked 12% incline	1400		1400	
	Unbraked	730		750	
	Towbar load limit	90		90	
	Max. roof load	100		100	
Performance	Top speed (where the law permits), mph (km/h)	126 (203)		124 (200)	
	Acceleration, secs 0 - 62 mph	10.5		10.8	
	ABI insurance group, 1 - 20 (1 - 50) ‡	8E (16E), 8E (16E)		8E (16E), 9E (16E)	
Environmental information	Fuel grade, minimum	Unleaded, 95 RON ⁽⁰⁴⁾		Unleaded, 95 RON ⁽⁰⁴⁾	
	Fuel tank capacity, galls/ltrs	15.4/70		15.4/70	
	Official fuel consumption, mpg/ltr per 100 km ⁽⁰⁵⁾				
	Urban	32.5/8.7		31.7/8.9	
	Extra-urban	52.3/5.4		50.4/5.6	
	Combined	42.2/6.7		41.5/6.8	
	Official CO ₂ emission, g/km ⁽⁰⁶⁾	155		158	
	Emission class	EURO 5		EURO 5	
Noise, dB	72.0		72.0		

Notes

- 01) The maximum power output figures are quoted in PS (or Pferdestärke, which is the metric equivalent of horsepower). To convert from metric to imperial horsepower, divide the PS figure by 1.0139.
- 02) Figures are calculated in accordance with manufacturer's criteria. The individual unladen weight depends on the specification of the vehicle, this then reduces the possible payload accordingly. The unladen weight and payload both include the fuel tank 90% full, driver (68 kg) and luggage (7 kg) in line with EU directive 95/48.
- 03) With increasing altitude the engine performance diminishes. From 1,000 m above sea level and for every 1,000 m thereafter 10% of the vehicle/trailer weight (trailer weight + gross vehicle weight) must be deducted.
- 04) Thanks to the knock control, unleaded four star (at least 95 RON) can be used instead of unleaded Super plus. In order to achieve maximum fuel consumption benefits on the FSI engine, Ultra Low Sulphur Petrol (ULSP) must be used.
- 05) Official fuel consumption according to EU Directive 99/94. The consumption calculation according to 1999/100/EC is based on the actual unladen weight of the vehicle. Additional specifications can lead to a higher weight class and hence to consumption figures of this higher weight class. The driving style, road and traffic conditions, environmental influences and vehicle condition can in practice lead to consumption figures, which may differ from those calculated with this standard.
- 06) The weight of a vehicle will influence the level of CO₂ emission it produces; as a result, vehicles with higher levels of specification and factory-fitted options may emit higher levels of CO₂.
- 07) The use of RME and FAME (bio diesel) is not possible.

‡ Please note, as of December 2009 the insurance industry switched from the current rating system of groups 1 - 20 to a new 1 - 50 insurance scale.

S†, R Line†, Highline, Highline Plus – 1.8 litre TSI 160 PS Technical specification

		Saloon		Estate	
		Manual	Automatic	Manual	Automatic
Engine	Engine type	Four cylinder petrol		Four cylinder petrol	
	Cubic capacity, ltrs/cc	1.8/1798	1.8/1798	1.8/1798	1.8/1798
	Max. output, PS ⁽⁰¹⁾ /kW	160/118	160/118	160/118	160/118
	at rpm	5000	5000	5000	5000
	Max. torque, lbs.ft/Nm	185/250	185/250	185/250	185/250
	at rpm	1500	1500	1500	1500
	Gearbox	6 spd	7 spd DSG†	6 spd	7 spd DSG†
Weights, kgs	Unladen weight ⁽⁰²⁾	1469	1504	1527	1541
	Gross vehicle weight	2030	2060	2110	2140
	Payload ⁽⁰²⁾	636	631	658	674
	Axle load limit: Front	1080	1100	1080	1100
	Rear	1000	1000	1100	1080
Trailer load limits, kgs ⁽⁰³⁾	Braked 12% incline	1500	1500	1500	1500
	Unbraked	730	750	750	750
	Towbar load limit	90	90	90	90
	Max. roof load	100	100	100	100
Performance	Top speed (where the law permits), mph (km/h)	137 (220)	136 (218)	135 (217)	133 (215)
	Acceleration, secs 0 - 62 mph	8.6	8.5	8.8	8.7
	ABI insurance group, 1 - 20 (1 - 50)‡	13E (22E), 13E (22E), 13E (22E), 13E (22E)	13E (22E), 13E (22E)	13E (22E), 13E (22E), 13E (22E), 13E (22E)	13E (22E), 13E (22E)
Environmental information	Fuel grade, minimum	Unleaded, 95 RON ⁽⁰⁴⁾		Unleaded, 95 RON ⁽⁰⁴⁾	
	Fuel tank capacity, galls/ltrs	15.4/70	15.4/70	15.4/70	15.4/70
	Official fuel consumption, mpg/ltr per 100 km ⁽⁰⁵⁾				
	Urban	28.5/9.9	28.8/9.8	28.5/9.9	28.2/10.0
	Extra-urban	47.9/5.9	48.7/5.8	47.1/6.0	48.7/5.8
	Combined	38.2/7.4	38.7/7.3	37.7/7.5	38.2/7.4
	Official CO ₂ emission, g/km ⁽⁰⁶⁾	172	169	174	171
	Emission class	EURO 5	EURO 5	EURO 5	EURO 5
Noise, dB	71.0	70.0	71.0	70.0	

Notes

- 01) The maximum power output figures are quoted in PS (or Pferdestärke, which is the metric equivalent of horsepower). To convert from metric to imperial horsepower, divide the PS figure by 1.0139.
- 02) Figures are calculated in accordance with manufacturer's criteria. The individual unladen weight depends on the specification of the vehicle, this then reduces the possible payload accordingly. The unladen weight and payload both include the fuel tank 90% full, driver (68 kg) and luggage (7 kg) in line with EU directive 95/48.
- 03) With increasing altitude the engine performance diminishes. From 1,000 m above sea level and for every 1,000 m thereafter 10% of the vehicle/trailer weight (trailer weight + gross vehicle weight) must be deducted.
- 04) Thanks to the knock control, unleaded four star (at least 95 RON) can be used instead of unleaded Super plus. In order to achieve maximum fuel consumption benefits on the FSI engine, Ultra Low Sulphur Petrol (ULSP) must be used.
- 05) Official fuel consumption according to EU Directive 99/94. The consumption calculation according to 1999/100/EC is based on the actual unladen weight of the vehicle. Additional specifications can lead to a higher weight class and hence to consumption figures of this higher weight class. The driving style, road and traffic conditions, environmental influences and vehicle condition can in practice lead to consumption figures, which may differ from those calculated with this standard.
- 06) The weight of a vehicle will influence the level of CO₂ emission it produces; as a result, vehicles with higher levels of specification and factory-fitted options may emit higher levels of CO₂.
- 07) The use of RME and FAME (bio diesel) is not possible.

† Seven speed auto DSG gearbox not available on these models.

‡ Please note, as of December 2009 the insurance industry switched from the current rating system of groups 1 - 20 to a new 1 - 50 insurance scale.

R36 – 3.6 litre FSI V6 4MOTION 300 PS

Technical specification

		Saloon		Estate	
		Manual	Automatic	Manual	Automatic
Engine	Engine type	Six cylinder petrol		Six cylinder petrol	
	Cubic capacity, ltrs/cc		3.6/3597		3.6/3597
	Max. output, PS ⁽⁰¹⁾ /kW		300/220		300/220
	at rpm		6600		6600
	Max. torque, lbs.ft/Nm		258/350		258/350
	at rpm		2400		2400
	Gearbox		6 spd DSG		6 spd DSG
Weights, kgs	Unladen weight ⁽⁰²⁾		1736		1800
	Gross vehicle weight		2270		2350
	Payload ⁽⁰²⁾		609		625
	Axle load limit: Front		1170		1170
	Rear		1150		1230
Trailer load limits, kgs ⁽⁰³⁾	Braked 12% incline		2200		2200
	Unbraked		750		750
	Towbar load limit		90		90
	Max. roof load		100		100
Performance	Top speed (where the law permits), mph (km/h)		155 (250)		155 (250)
	Acceleration, secs 0 - 62 mph		5.6		5.8
	ABI insurance group, 1 - 20 (1 - 50) [‡]		18E (36E)		18E (36E)
Environmental information	Fuel grade, minimum	Unleaded, 95 RON ⁽⁰⁴⁾		Unleaded, 95 RON ⁽⁰⁴⁾	
	Fuel tank capacity, galls/ltrs		15.0/68		15.0/68
	Official fuel consumption, mpg/ltr per 100 km ⁽⁰⁵⁾				
	Urban		22.1/12.8		21.9/12.9
	Extra-urban		35.3/8.0		34.9/8.1
	Combined		28.8/9.8		28.5/9.9
	Official CO ₂ emission, g/km ⁽⁰⁶⁾		227		229
	Emission class		EURO 5		EURO 5
Noise, dB		73.0		73.0	

Notes

- 01) The maximum power output figures are quoted in PS (or Pferdestärke, which is the metric equivalent of horsepower). To convert from metric to imperial horsepower, divide the PS figure by 1.0139.
- 02) Figures are calculated in accordance with manufacturer's criteria. The individual unladen weight depends on the specification of the vehicle, this then reduces the possible payload accordingly. The unladen weight and payload both include the fuel tank 90% full, driver (68 kg) and luggage (7 kg) in line with EU directive 95/48.
- 03) With increasing altitude the engine performance diminishes. From 1,000 m above sea level and for every 1,000 m thereafter 10% of the vehicle/trailer weight (trailer weight + gross vehicle weight) must be deducted.
- 04) Thanks to the knock control, unleaded four star (at least 95 RON) can be used instead of unleaded Super plus. In order to achieve maximum fuel consumption benefits on the FSI engine, Ultra Low Sulphur Petrol (ULSP) must be used.
- 05) Official fuel consumption according to EU Directive 99/94. The consumption calculation according to 1999/100/EC is based on the actual unladen weight of the vehicle. Additional specifications can lead to a higher weight class and hence to consumption figures of this higher weight class. The driving style, road and traffic conditions, environmental influences and vehicle condition can in practice lead to consumption figures, which may differ from those calculated with this standard.
- 06) The weight of a vehicle will influence the level of CO₂ emission it produces; as a result, vehicles with higher levels of specification and factory-fitted options may emit higher levels of CO₂.
- 07) The use of RME and FAME (bio diesel) is not possible.

‡ Please note, as of December 2009 the insurance industry switched from the current rating system of groups 1 - 20 to a new 1 - 50 insurance scale.

S BlueMotion Technology – 1.6 litre TDI 105 PS Technical specification

		Saloon		Estate	
		Manual	Automatic	Manual	Automatic
Engine	Engine type	Four cylinder diesel		Four cylinder diesel	
	Cubic capacity, ltrs/cc	1.6/1598		1.6/1598	
	Max. output, PS ⁽⁰¹⁾ /kW	105/77		105/77	
	at rpm	4400		4400	
	Max. torque, lbs.ft/Nm	185/250		185/250	
	at rpm	1500-2500		1500	
	Gearbox	5 spd		5 spd	
Weights, kgs	Unladen weight ⁽⁰²⁾	1486		1540	
	Gross vehicle weight	2000		2060	
	Payload ⁽⁰²⁾	589		595	
	Axle load limit: Front	1060		1060	
	Rear	990		1050	
Trailer load limits, kgs ⁽⁰³⁾	Braked 12% incline	1400		1400	
	Unbraked	740		750	
	Towbar load limit	90		90	
	Max. roof load	100		100	
Performance	Top speed (where the law permits), mph (km/h)	120 (193)		118 (190)	
	Acceleration, secs 0 - 62 mph	12.4		12.7	
	ABI insurance group, 1 - 20 (1 - 50) [‡]	7E (15E)		7E (15E)	
Environmental information	Fuel grade, minimum	Diesel ⁽⁰⁷⁾		Diesel ⁽⁰⁷⁾	
	Fuel tank capacity, galls/ltrs	15.4/70		15.4/70	
	Official fuel consumption, mpg/ltr per 100 km ⁽⁰⁵⁾				
	Urban	51.4/5.5		51.4/5.5	
	Extra-urban	74.3/3.8		72.4/3.9	
	Combined	62.8/4.5		62.8/4.5	
	Official CO ₂ emission, g/km ⁽⁰⁶⁾	118		119	
	Emission class	EURO 5		EURO 5	
Noise, dB	70.0		70.0		

Notes

- 01) The maximum power output figures are quoted in PS (or Pferdestärke, which is the metric equivalent of horsepower). To convert from metric to imperial horsepower, divide the PS figure by 1.0139.
- 02) Figures are calculated in accordance with manufacturer's criteria. The individual unladen weight depends on the specification of the vehicle, this then reduces the possible payload accordingly. The unladen weight and payload both include the fuel tank 90% full, driver (68 kg) and luggage (7 kg) in line with EU directive 95/48.
- 03) With increasing altitude the engine performance diminishes. From 1,000 m above sea level and for every 1,000 m thereafter 10% of the vehicle/trailer weight (trailer weight + gross vehicle weight) must be deducted.
- 04) Thanks to the knock control, unleaded four star (at least 95 RON) can be used instead of unleaded Super plus. In order to achieve maximum fuel consumption benefits on the FSI engine, Ultra Low Sulphur Petrol (ULSP) must be used.
- 05) Official fuel consumption according to EU Directive 99/94. The consumption calculation according to 1999/100/EC is based on the actual unladen weight of the vehicle. Additional specifications can lead to a higher weight class and hence to consumption figures of this higher weight class. The driving style, road and traffic conditions, environmental influences and vehicle condition can in practice lead to consumption figures, which may differ from those calculated with this standard.
- 06) The weight of a vehicle will influence the level of CO₂ emission it produces; as a result, vehicles with higher levels of specification and factory-fitted options may emit higher levels of CO₂.
- 07) The use of RME and FAME (bio diesel) is not possible.

‡ Please note, as of December 2009 the insurance industry switched from the current rating system of groups 1 - 20 to a new 1 - 50 insurance scale.

BlueMotion – 1.6 litre TDI 105 PS Technical specification

		Saloon		Estate	
		Manual	Automatic	Manual	Automatic
Engine	Engine type	Four cylinder diesel		Four cylinder diesel	
	Cubic capacity, ltrs/cc	1.6/1598		1.6/1598	
	Max. output, PS ⁽⁰¹⁾ /kW	105/77		105/77	
	at rpm	4400		4400	
	Max. torque, lbs.ft/Nm	185/250		185/250	
	at rpm	1500-2500		1500	
	Gearbox	5 spd		5 spd	
Weights, kgs	Unladen weight ⁽⁰²⁾	1495		1530	
	Gross vehicle weight	1990		1980	
	Payload ⁽⁰²⁾	570		525	
	Axle load limit: Front Rear	1040 970		1020 1010	
Trailer load limits, kgs ⁽⁰³⁾	Braked 12% incline	1400		1200	
	Unbraked	740		750	
	Towbar load limit	90		90	
	Max. roof load	100		100	
Performance	Top speed (where the law permits), mph (km/h)	120 (193)		118 (190)	
	Acceleration, secs 0 - 62 mph	12.4		12.7	
	ABI insurance group, 1 - 20 (1 - 50) [‡]	7E (15E)		7E (15E)	
Environmental information	Fuel grade, minimum	Diesel ⁽⁰⁷⁾		Diesel ⁽⁰⁷⁾	
	Fuel tank capacity, galls/ltrs	15.4/70		15.4/70	
	Official fuel consumption, mpg/ltr per 100 km ⁽⁰⁵⁾				
	Urban	52.3/5.4		52.3/5.4	
	Extra-urban	74.3/3.8		74.3/3.8	
	Combined	64.2/4.4		64.2/4.4	
	Official CO ₂ emission, g/km ⁽⁰⁶⁾	114		114	
Emission class	EURO 5		EURO 5		
Noise, dB	70.0		70.0		

Notes

- 01) The maximum power output figures are quoted in PS (or Pferdestärke, which is the metric equivalent of horsepower). To convert from metric to imperial horsepower, divide the PS figure by 1.0139.
- 02) Figures are calculated in accordance with manufacturer's criteria. The individual unladen weight depends on the specification of the vehicle, this then reduces the possible payload accordingly. The unladen weight and payload both include the fuel tank 90% full, driver (68 kg) and luggage (7 kg) in line with EU directive 95/48.
- 03) With increasing altitude the engine performance diminishes. From 1,000 m above sea level and for every 1,000 m thereafter 10% of the vehicle/trailer weight (trailer weight + gross vehicle weight) must be deducted.
- 04) Thanks to the knock control, unleaded four star (at least 95 RON) can be used instead of unleaded Super plus. In order to achieve maximum fuel consumption benefits on the FSI engine, Ultra Low Sulphur Petrol (ULSP) must be used.
- 05) Official fuel consumption according to EU Directive 99/94. The consumption calculation according to 1999/100/EC is based on the actual unladen weight of the vehicle. Additional specifications can lead to a higher weight class and hence to consumption figures of this higher weight class. The driving style, road and traffic conditions, environmental influences and vehicle condition can in practice lead to consumption figures, which may differ from those calculated with this standard.
- 06) The weight of a vehicle will influence the level of CO₂ emission it produces; as a result, vehicles with higher levels of specification and factory-fitted options may emit higher levels of CO₂.
- 07) The use of RME and FAME (bio diesel) is not possible.

‡ Please note, as of December 2009 the insurance industry switched from the current rating system of groups 1 - 20 to a new 1 - 50 insurance scale.

S, R Line, Highline, Highline Plus – 2.0 litre TDI 110 PS Technical specification

		Saloon		Estate	
		Manual	Automatic	Manual	Automatic
Engine	Engine type	Four cylinder diesel		Four cylinder diesel	
	Cubic capacity, ltrs/cc	2.0/1968		2.0/1968	
	Max. output, PS ⁽⁰¹⁾ /kW	110/81		110/81	
	at rpm	4200		4200	
	Max. torque, lbs.ft/Nm	185/250		185/250	
	at rpm	1500		1500	
	Gearbox	5 spd		5 spd	
Weights, kgs	Unladen weight ⁽⁰²⁾	1510		1557	
	Gross vehicle weight	2080		2160	
	Payload ⁽⁰²⁾	645		678	
	Axle load limit: Front Rear	1110 1020		1110 1110	
Trailer load limits, kgs⁽⁰³⁾	Braked 12% incline	1500		1500	
	Unbraked	750		750	
	Towbar load limit	90		90	
	Max. roof load	100		100	
Performance	Top speed (where the law permits), mph (km/h)	119 (192)		118 (190)	
	Acceleration, secs 0 - 62 mph	11.8		12.0	
	ABI insurance group, 1 - 20 (1 - 50) [‡]	8E (16E), 8E (16E), 8E (16E), 8E (16E)		8E (16E), 8E (16E), 8E (16E), 8E (16E)	
Environmental information	Fuel grade, minimum	Diesel ⁽⁰⁷⁾		Diesel ⁽⁰⁷⁾	
	Fuel tank capacity, galls/ltrs	15.4/70		15.4/70	
	Official fuel consumption, mpg/ltr per 100 km ⁽⁰⁵⁾				
	Urban	40.4/7.0		39.8/7.1	
	Extra-urban	62.8/4.5		60.1/4.7	
	Combined	51.4/5.5		50.4/5.6	
	Official CO ₂ emission, g/km ⁽⁰⁶⁾	143		146	
Emission class	EURO 5		EURO 5		
	Noise, dB	71.0		71.0	

Notes

- 01) The maximum power output figures are quoted in PS (or Pferdestärke, which is the metric equivalent of horsepower). To convert from metric to imperial horsepower, divide the PS figure by 1.0139.
- 02) Figures are calculated in accordance with manufacturer's criteria. The individual unladen weight depends on the specification of the vehicle, this then reduces the possible payload accordingly. The unladen weight and payload both include the fuel tank 90% full, driver (68 kg) and luggage (7 kg) in line with EU directive 95/48.
- 03) With increasing altitude the engine performance diminishes. From 1,000 m above sea level and for every 1,000 m thereafter 10% of the vehicle/trailer weight (trailer weight + gross vehicle weight) must be deducted.
- 04) Thanks to the knock control, unleaded four star (at least 95 RON) can be used instead of unleaded Super plus. In order to achieve maximum fuel consumption benefits on the FSI engine, Ultra Low Sulphur Petrol (ULSP) must be used.
- 05) Official fuel consumption according to EU Directive 99/94. The consumption calculation according to 1999/100/EC is based on the actual unladen weight of the vehicle. Additional specifications can lead to a higher weight class and hence to consumption figures of this higher weight class. The driving style, road and traffic conditions, environmental influences and vehicle condition can in practice lead to consumption figures, which may differ from those calculated with this standard.
- 06) The weight of a vehicle will influence the level of CO₂ emission it produces; as a result, vehicles with higher levels of specification and factory-fitted options may emit higher levels of CO₂.
- 07) The use of RME and FAME (bio diesel) is not possible.

‡ Please note, as of December 2009 the insurance industry switched from the current rating system of groups 1 - 20 to a new 1 - 50 insurance scale.

S, R Line, Highline, Highline Plus – 2.0 litre TDI 140 PS

Technical specification

		Saloon		Estate	
		Manual	Automatic	Manual	Automatic
Engine	Engine type	Four cylinder diesel		Four cylinder diesel	
	Cubic capacity, ltrs/cc	2.0/1968	2.0/1968	2.0/1968	2.0/1968
	Max. output, PS ⁽⁰¹⁾ /kW	140/103	140/103	140/103	140/103
	at rpm	4200	4200	4200	4200
	Max. torque, lbs.ft/Nm	236/320	236/320	236/320	236/320
	at rpm	1750	1750	1750	1750
	Gearbox	6 spd	6 spd DSG	6 spd	6 spd DSG
Weights, kgs	Unladen weight ⁽⁰²⁾	1527	1476	1572	1594
	Gross vehicle weight	2090	2110	2170	2190
	Payload ⁽⁰²⁾	638	636	673	671
	Axle load limit: Front	1100	1130	1120	1140
	Rear	1010	1010	1110	1110
Trailer load limits, kgs ⁽⁰³⁾	Braked 12% incline	1800	1800	1800	1800
	Unbraked	750	750	750	750
	Towbar load limit	90	90	90	90
	Max. roof load	100	100	100	100
Performance	Top speed (where the law permits), mph (km/h)	130 (209)	128 (206)	128 (206)	126 (203)
	Acceleration, secs 0 - 62 mph	9.8	9.8	10.1	10.1
	ABI insurance group, 1 - 20 (1 - 50) [‡]	10E (20E), 10E (21E), 10E (21E), 11E (21E)	10E (20E), 10E (21E), 10E (21E), 11E (21E)	10E (20E), 10E (21E), 11E (21E), 11E (21E)	10E (20E), 10E (21E), 11E (21E), 11E (21E)
Environmental information	Fuel grade, minimum	Diesel ⁽⁰⁷⁾		Diesel ⁽⁰⁷⁾	
	Fuel tank capacity, galls/ltrs	15.4/70	15.4/70	15.4/70	15.4/70
	Official fuel consumption, mpg/ltr per 100 km ⁽⁰⁵⁾				
	Urban	39.2/7.2	36.2/7.8	38.7/7.3	35.8/7.9
	Extra-urban	61.4/4.6	56.5/5.0	60.1/4.7	56.5/5.0
	Combined	50.4/5.6	47.1/6.0	49.6/5.7	46.3/6.1
	Official CO ₂ emission, g/km ⁽⁰⁶⁾	146	158	148	159
	Emission class	EURO 5	EURO 5	EURO 5	EURO 5
Noise, dB	70.0	68.0	70.0	68.0	

Notes

- 01) The maximum power output figures are quoted in PS (or Pferdestärke, which is the metric equivalent of horsepower). To convert from metric to imperial horsepower, divide the PS figure by 1.0139.
- 02) Figures are calculated in accordance with manufacturer's criteria. The individual unladen weight depends on the specification of the vehicle, this then reduces the possible payload accordingly. The unladen weight and payload both include the fuel tank 90% full, driver (68 kg) and luggage (7 kg) in line with EU directive 95/48.
- 03) With increasing altitude the engine performance diminishes. From 1,000 m above sea level and for every 1,000 m thereafter 10% of the vehicle/trailer weight (trailer weight + gross vehicle weight) must be deducted.
- 04) Thanks to the knock control, unleaded four star (at least 95 RON) can be used instead of unleaded Super plus. In order to achieve maximum fuel consumption benefits on the FSI engine, Ultra Low Sulphur Petrol (ULSP) must be used.
- 05) Official fuel consumption according to EU Directive 99/94. The consumption calculation according to 1999/100/EC is based on the actual unladen weight of the vehicle. Additional specifications can lead to a higher weight class and hence to consumption figures of this higher weight class. The driving style, road and traffic conditions, environmental influences and vehicle condition can in practice lead to consumption figures, which may differ from those calculated with this standard.
- 06) The weight of a vehicle will influence the level of CO₂ emission it produces; as a result, vehicles with higher levels of specification and factory-fitted options may emit higher levels of CO₂.
- 07) The use of RME and FAME (bio diesel) is not possible.

[‡] Please note, as of December 2009 the insurance industry switched from the current rating system of groups 1 - 20 to a new 1 - 50 insurance scale.

**Highline BlueMotion Tech, Highline Plus BlueMotion Tech
– 2.0 litre TDI 140 PS**
Technical specification

		Saloon		Estate	
		Manual	Automatic	Manual	Automatic
Engine	Engine type	Four cylinder diesel		Four cylinder diesel	
	Cubic capacity, ltrs/cc	2.0/1968		2.0/1968	
	Max. output, PS ⁽⁰¹⁾ /kW	140/103		140/103	
	at rpm	4200		4200	
	Max. torque, lbs.ft./Nm	236/320		236/320	
	at rpm	1750		1750	
	Gearbox	6 spd		6 spd	
Weights, kgs	Unladen weight ⁽⁰²⁾	1523		1559	
	Gross vehicle weight	2040		2160	
	Payload ⁽⁰²⁾	592		676	
	Axle load limit: Front Rear	1090 1000		1110 1100	
Trailer load limits, kgs ⁽⁰³⁾	Braked 12% incline	1600		1600	
	Unbraked	750		750	
	Towbar load limit	90		90	
	Max. roof load	100		100	
Performance	Top speed (where the law permits), mph (km/h)	130 (210)		129 (208)	
	Acceleration, secs 0 - 62 mph	9.8		10.1	
	ABI insurance group, 1 - 20 (1 - 50) [‡]	11E (20E), 11E (21E)		11E (20E), 11E (20E)	
Environmental information	Fuel grade, minimum	Diesel ⁽⁰⁷⁾		Diesel ⁽⁰⁷⁾	
	Fuel tank capacity, galls/ltrs	15.4/70		15.4/70	
	Official fuel consumption, mpg/ltr per 100 km ⁽⁰⁵⁾				
	Urban	47.1/6.0		46.3/6.1	
	Extra-urban	70.6/4.0		67.3/4.2	
	Combined	60.1/4.7		58.9/4.8	
	Official CO ₂ emission, g/km ⁽⁰⁶⁾	124		127	
	Emission class	EURO 5		EURO 5	
Noise, dB	70.0		70.0		

Notes

- 01) The maximum power output figures are quoted in PS (or Pferdestärke, which is the metric equivalent of horsepower). To convert from metric to imperial horsepower, divide the PS figure by 1.0139.
- 02) Figures are calculated in accordance with manufacturer's criteria. The individual unladen weight depends on the specification of the vehicle, this then reduces the possible payload accordingly. The unladen weight and payload both include the fuel tank 90% full, driver (68 kg) and luggage (7 kg) in line with EU directive 95/48.
- 03) With increasing altitude the engine performance diminishes. From 1,000 m above sea level and for every 1,000 m thereafter 10% of the vehicle/trailer weight (trailer weight + gross vehicle weight) must be deducted.
- 04) Thanks to the knock control, unleaded four star (at least 95 RON) can be used instead of unleaded Super plus. In order to achieve maximum fuel consumption benefits on the FSI engine, Ultra Low Sulphur Petrol (ULSP) must be used.
- 05) Official fuel consumption according to EU Directive 99/94. The consumption calculation according to 1999/100/EC is based on the actual unladen weight of the vehicle. Additional specifications can lead to a higher weight class and hence to consumption figures of this higher weight class. The driving style, road and traffic conditions, environmental influences and vehicle condition can in practice lead to consumption figures, which may differ from those calculated with this standard.
- 06) The weight of a vehicle will influence the level of CO₂ emission it produces; as a result, vehicles with higher levels of specification and factory-fitted options may emit higher levels of CO₂.
- 07) The use of RME and FAME (bio diesel) is not possible.

[‡] Please note, as of December 2009 the insurance industry switched from the current rating system of groups 1 - 20 to a new 1 - 50 insurance scale.

Highline, Highline Plus – 2.0 litre TDI 170 PS

Technical specification

		Saloon		Estate	
		Manual	Automatic	Manual	Automatic
Engine	Engine type	Four cylinder diesel		Four cylinder diesel	
	Cubic capacity, ltrs/cc	2.0/1968	2.0/1968	2.0/1968	2.0/1968
	Max. output, PS ⁽⁰¹⁾ /kW	170/125	170/125	170/125	170/125
	at rpm	4200	4200	4200	4200
	Max. torque, lbs.ft./Nm	258/350	258/350	258/350	258/350
	at rpm	1750	1750	1750	1750
	Gearbox	6 spd	6 spd DSG	6 spd	6 spd DSG
Weights, kgs	Unladen weight ⁽⁰²⁾	1530	1552	1574	1596
	Gross vehicle weight	2090	2110	2170	2190
	Payload ⁽⁰²⁾	635	633	671	669
	Axle load limit: Front	1100	1130	1100	1130
	Rear	1010	1010	1090	1090
Trailer load limits, kgs ⁽⁰³⁾	Braked 12% incline	1800	1800	1800	1800
	Unbraked	750	750	750	750
	Towbar load limit	90	90	90	90
	Max. roof load	100	100	100	100
Performance	Top speed (where the law permits), mph (km/h)	139 (223)	137 (220)	137 (220)	135 (217)
	Acceleration, secs 0 - 62 mph	8.6	8.6	8.8	8.8
	ABI insurance group, 1 - 20 (1 - 50) ‡	13E (24E), 13E (24E)	13E (24E), 13E (24E)	13E (24E), 13E (24E)	13E (24E), 13E (24E)
Environmental information	Fuel grade, minimum	Diesel ⁽⁰⁷⁾		Diesel ⁽⁰⁷⁾	
	Fuel tank capacity, galls/ltrs	15.4/70	15.4/70	15.4/70	15.4/70
	Official fuel consumption, mpg/ltr per 100 km ⁽⁰⁵⁾				
	Urban	38.2/7.4	36.2/7.8	38.2/7.4	35.3/8.0
	Extra-urban	61.4/4.6	55.4/5.1	60.1/4.7	54.3/5.2
	Combined	50.4/5.6	46.3/6.1	49.6/5.7	45.6/6.2
	Official CO ₂ emission, g/km ⁽⁰⁶⁾	146	159	149	163
	Emission class	EURO 5	EURO 5	EURO 5	EURO 5
Noise, dB	73.0	69.0	73.0	69.0	

Notes

- 01) The maximum power output figures are quoted in PS (or Pferdestärke, which is the metric equivalent of horsepower). To convert from metric to imperial horsepower, divide the PS figure by 1.0139.
- 02) Figures are calculated in accordance with manufacturer's criteria. The individual unladen weight depends on the specification of the vehicle, this then reduces the possible payload accordingly. The unladen weight and payload both include the fuel tank 90% full, driver (68 kg) and luggage (7 kg) in line with EU directive 95/48.
- 03) With increasing altitude the engine performance diminishes. From 1,000 m above sea level and for every 1,000 m thereafter 10% of the vehicle/trailer weight (trailer weight + gross vehicle weight) must be deducted.
- 04) Thanks to the knock control, unleaded four star (at least 95 RON) can be used instead of unleaded Super plus. In order to achieve maximum fuel consumption benefits on the FSI engine, Ultra Low Sulphur Petrol (ULSP) must be used.
- 05) Official fuel consumption according to EU Directive 99/94. The consumption calculation according to 1999/100/EC is based on the actual unladen weight of the vehicle. Additional specifications can lead to a higher weight class and hence to consumption figures of this higher weight class. The driving style, road and traffic conditions, environmental influences and vehicle condition can in practice lead to consumption figures, which may differ from those calculated with this standard.
- 06) The weight of a vehicle will influence the level of CO₂ emission it produces; as a result, vehicles with higher levels of specification and factory-fitted options may emit higher levels of CO₂.
- 07) The use of RME and FAME (bio diesel) is not possible.

‡ Please note, as of December 2009 the insurance industry switched from the current rating system of groups 1 - 20 to a new 1 - 50 insurance scale.

The technology

Transmission

- Front wheel drive through asbestos-free single-plate dry clutch. Hydraulic clutch-mechanism. Five/six speed manual or six/seven speed auto DSG gearbox with double joint half axles
- Four wheel drive (R36 only) with electronically controlled multi-plate clutch. Electronic differential lock, combined with a hydraulically operated single-plate dry clutch with asbestos-free lining via a six speed auto DSG gearbox
- Five speed manual: 1.6 litre TDI 105 PS, 2.0 litre TDI 110 PS
- Six speed manual: 1.4 litre TSI 122 PS, 1.8 litre TSI 160 PS, 2.0 litre TDI 140 PS, 2.0 litre TDI 170 PS
- Six speed auto DSG: 3.6 litre FSI V6 4MOTION 300 PS, 2.0 litre TDI 140 PS, 2.0 litre TDI 170 PS
- Seven speed auto DSG: 1.8 litre TSI 160 PS

Running gear

- Electronic Stabilisation Programme (ESP) including Electronic Differential Lock (EDL), Traction Control (ASR) and Countersteer Support
- Front suspension through coil springs with telescopic shock absorbers, all elements integrated in chassis legs
- Rear suspension with gas pressure shock absorbers and separate springs
- Wheel control: front through chassis legs and (lower) triangular wishbones (directionally stabilising steering roll radius)
- Wheel control: rear through four-link suspension with independent wheel suspension
- Front and rear anti-roll bar

Brakes

- Electronically controlled Anti-lock Braking System (ABS) – includes BAS (Brake Assist System) and Electronic Brake-pressure Distribution (EBD)
- Diagonal twin-circuit brake system with inner-ventilated front disc brakes and rear disc brakes (front ventilated on R36)
- Asbestos-free brake pads
- Electronic park brake

Steering

- Electro-mechanical steering rack
- Collapsible, height and lengthways adjustable safety steering column

Engines

- Front transverse-installed engine
- 1.4 litre/122 PS⁽⁰¹⁾ (90 kW) petrol engine: CAXA TSI engine with homogeneous mode (Lambda 1), stratified high-pressure start, double injection catalytic converter heating, turbocharger with wastegate, air-to-liquid charge-air cooling, maintenance-free timing chain, plastic intake manifold with integrated intercooler, continuous inlet camshaft timing adjustment, grey cast iron cylinder block, steel crankshaft, duo-centric oil pump, dual-circuit cooling system. Fuel system regulated according to requirements using high-pressure fuel pump with integrated pressure limiting valve
- 1.8 litre/160 PS⁽⁰¹⁾ (118 kW) petrol engine: four cylinder in-line engine, four valves per cylinder, four-stroke turbocharged petrol engine, cast iron cylinder crankcase with balancer shafts, steel crankshaft and internal oil pump – chain driven by the crankshaft, timing gear chain and chain driven mass balancer at the front end of the engine, four valve cylinder head, one intake camshaft adjuster, intake manifold with tumble flap, demand controlled fuel supply on low and high pressure ends, multi-port high pressure injector, MED 17 engine control unit, hot-film digital air mass meter with integral temperature sensor, throttle valve with contactless sensor, map-controlled ignition with cylinder selective, digital knock control and single spark ignition coils, integral exhaust turbocharger, charge-air cooler, boost pressure control with overpressure and electrical wastegate valve, single chamber exhaust system with close-coupled pre-catalyst, no 'continuous' pre-catalyst oxygen sensor in the EU4, direct injection, homogeneous combustion process
- 3.6 litre/300 PS⁽⁰¹⁾ (220 kW) petrol engine: six cylinder transverse engine in 'V' format, aluminium cylinder head, four valves per cylinder with roller rocker valve lever drive, electronic indirect injection, six single spark ignition coils, lambda control
- 1.6 litre/105 PS⁽⁰¹⁾ (77 kW) common rail diesel engine: EU5 emissions standard, four cylinder in-line engine, four valves per cylinder, aluminium-silicon alloy cylinder head, reduced piston crown volume (improves swirl generation in the cylinder), toothed backlash compensator, intake manifold with electric continual tumble flap control, electronically controlled common rail direct injection fuel system with Bosch high pressure pump (up to 1800 bar) and 8-hole piezo injector units, pre-supply electronic fuel pump, oil cooler, intercooler, low temperature exhaust gas recirculation, additional coolant pump, turbocharger with variable turbine geometry, catalytic converter and Diesel Particulate Filter (DPF)
- 2.0 litre/110 PS⁽⁰¹⁾ (81 kW) common rail diesel engine: EU5 emissions standard, four cylinder in-line engine, four valves per cylinder, aluminium-silicon alloy cylinder head, reduced piston crown volume (improves swirl generation in the cylinder), toothed backlash compensator, intake manifold with electric continual tumble flap control, electronically controlled common rail direct injection fuel system with Bosch high pressure pump (up to 1800 bar) and 8-hole piezo injector units, pre-supply electronic fuel pump, oil cooler, intercooler, low temperature exhaust gas recirculation, additional coolant pump, turbocharger with variable turbine geometry, catalytic converter and Diesel Particulate Filter (DPF)
- 2.0 litre/140 PS⁽⁰¹⁾ (103 kW) common rail diesel engine: EU5 emissions standard, four cylinder in-line engine, four valves per cylinder, aluminium-silicon alloy cylinder head, reduced piston crown volume (improves swirl generation in the cylinder), toothed backlash compensator, intake manifold with electric continual tumble flap control, electronically controlled common rail direct injection fuel system with Bosch high pressure pump (up to 1800 bar) and 8-hole piezo injector units, pre-supply electronic fuel pump, oil cooler, intercooler, low temperature exhaust gas recirculation, additional coolant pump, turbocharger with variable turbine geometry, catalytic converter and Diesel Particulate Filter (DPF)
- 2.0 litre/170 PS⁽⁰¹⁾ (125 kW) common rail diesel engine: EU5 emissions standard, four cylinder in-line engine, four valves per cylinder, aluminium-silicon alloy cylinder head, reduced piston crown volume (improves swirl generation in the cylinder), toothed backlash compensator, intake manifold with electric continual tumble flap control, electronically controlled common rail direct injection fuel system with Bosch high pressure pump (up to 1800 bar) and 8-hole piezo injector units, pre-supply electronic fuel pump, oil cooler, intercooler, low temperature exhaust gas recirculation, additional coolant pump, turbocharger with variable turbine geometry, catalytic converter and Diesel Particulate Filter (DPF)

Technical specification dimensions

		Saloon	Estate
Maximum luggage capacity, litres VDA measuring method using 200 x 100 x 50 mm blocks	With rear seat upright	565 (541)	513 (498)
	With rear seat folded	1001 (977)	1641 (1626)
Exterior dimensions	Length, mm	4765 (4765)	4774 (4774)
	Width – excluding door mirrors, mm	1820 (1820)	1820 (1820)
	Width – opened front/rear doors, mm	3723/3587 (3723/3587)	3723/3462 (3723/3462)
	Height, mm	1472 (1472)	1517 (1517)
	Height – opened bonnet/floor, mm	1826 (1826)	1826 (1826)
	Height – opened tailgate/floor, mm	1756 (1756)	2058 (2058)
	Wheelbase, mm	2709 (2709)	2709 (2709)
	Turning circle, mm	11400 (11400)	11400 (11400)
Interior dimensions	Effective headroom – front, mm	973 (973)	970 (970)
	Effective headroom – front with sunroof, mm	951 (951)	952 (952)
	Effective headroom – rear, mm	961 (961)	980 (980)
	Effective headroom – rear with sunroof, mm	960 (960)	980 (980)
	Elbow width – front, mm	1466 (1466)	1466 (1466)
	Elbow width – rear, mm	1511 (1511)	1511 (1511)
	Legroom – front, mm	725 - 1038 (725 - 1038)	725 - 1038 (725 - 1038)

() R36 figures.

Passat Saloon

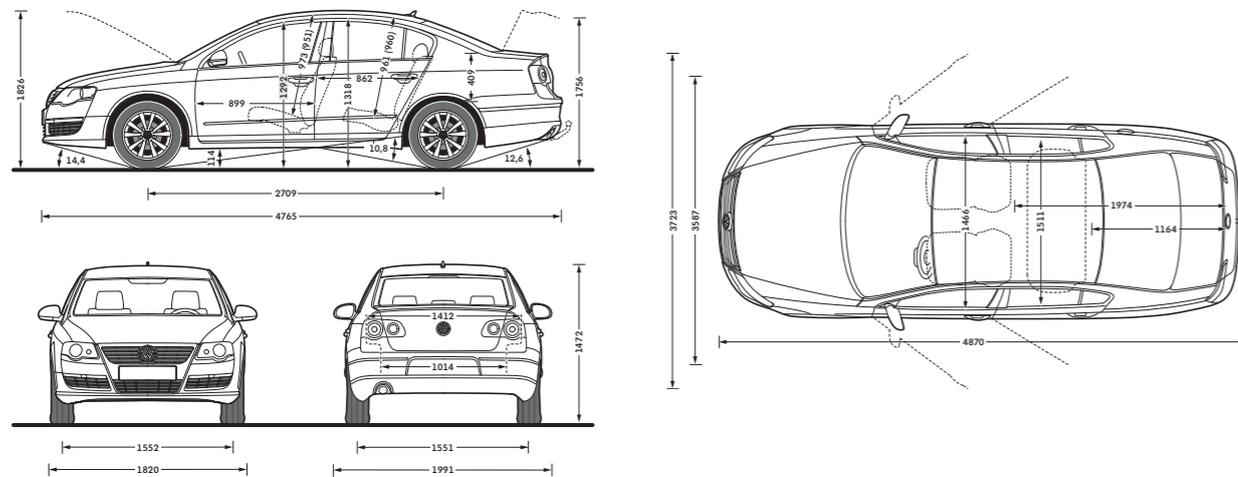

Passat Estate

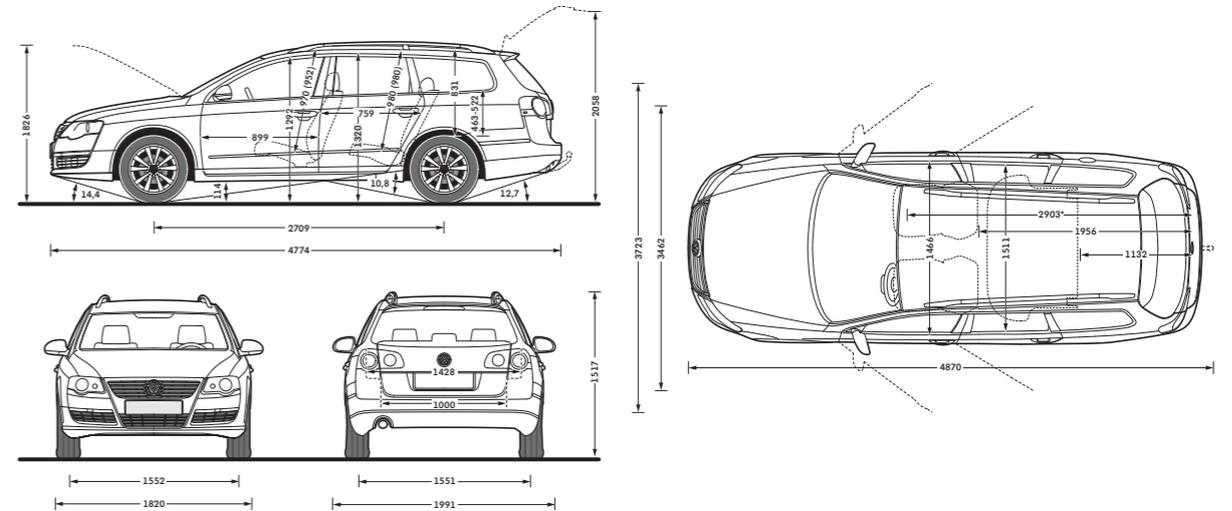

Safety

The most important consideration for any driver is safety. That's why it's so reassuring to drive the Passat. With a whole range of new generation safety features included as standard, the Passat provides the highest levels of safety possible, ensuring optimum protection in hazardous situations.

Of course, it's even better to avoid hazards in the first place, which is where the Passat's active safety concept comes in. An innovative suspension system, with a spring strut front axle and four-link rear axle, counteracts any unevenness in the road surface, keeping the Passat safely in place. At the same time, the driver benefits from electro-mechanical power-assisted steering, which reacts with extreme precision even at high speeds. The Electronic Stabilisation Programme (ESP) plays a further role, utilising Electronic Differential Lock (EDL), Traction Control (ASR) and Countersteer Support to help correct oversteer, understeer and loss of stability of the vehicle. The result is optimum traction when rounding bends. And to ensure you retain control on a slippery surface, the Anti-lock Braking System (ABS) prevents the wheels from locking in the event of an abrupt braking manoeuvre. Finally, an electronic tyre pressure monitoring system, standard on R36 models, automatically lets you know via the instrument panel, as soon as there is any change in the vehicle's tyre pressure.

The body of the Passat is formed from specially hardened components which possess high strength and excellent shaping characteristics. Thanks to the latest lightweight construction technology the body also offers optimal protection under heavy impact.

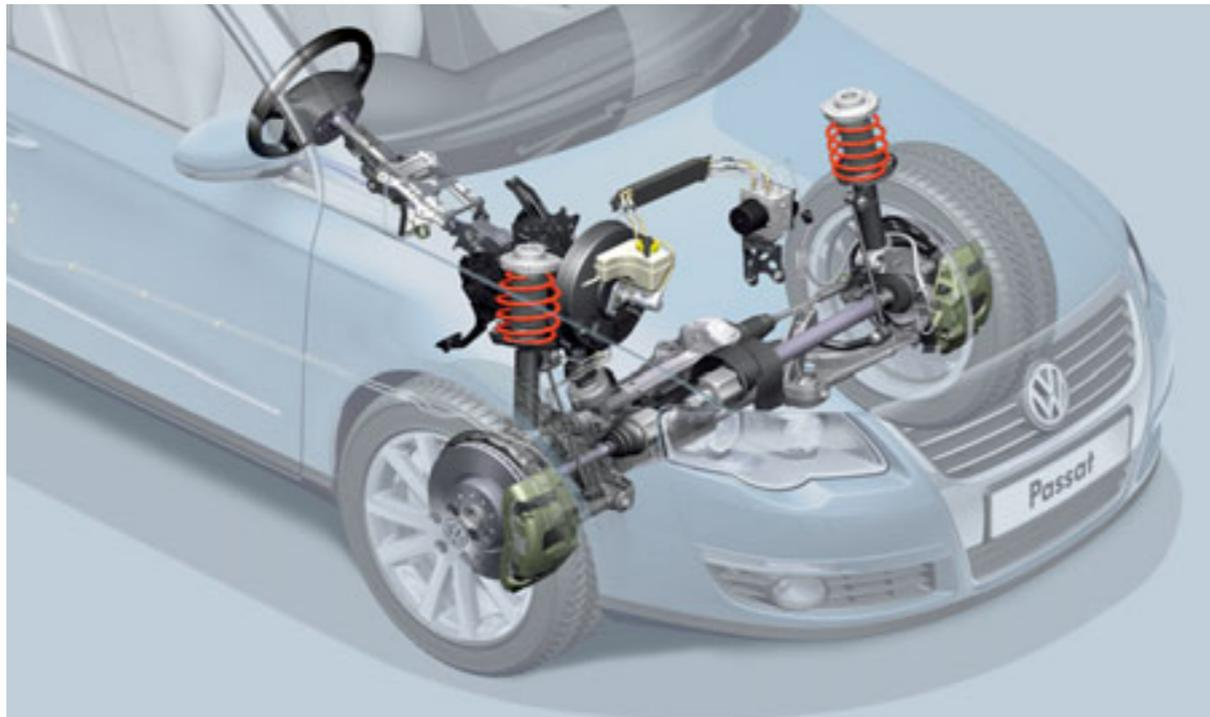

The front suspension system utilises a spring strut front axle, chassis legs and (lower) triangular wishbones (directionally stabilising steering roll radius).



The electronic tyre pressure monitoring system conveniently indicates changes in tyre pressure on the instrument display. Standard on R36 models.



Through a combination of Traction Control (ASR), Electronic Differential Lock (EDL) and Anti-lock Braking System (ABS), the Passat delivers exceptional handling and braking.



The Electronic Stabilisation Programme (ESP) detects critical situations at an early stage and takes action by, for example, specifically braking individual wheels.



Rear wheel control is implemented through a four-link suspension system with independent wheel suspension.

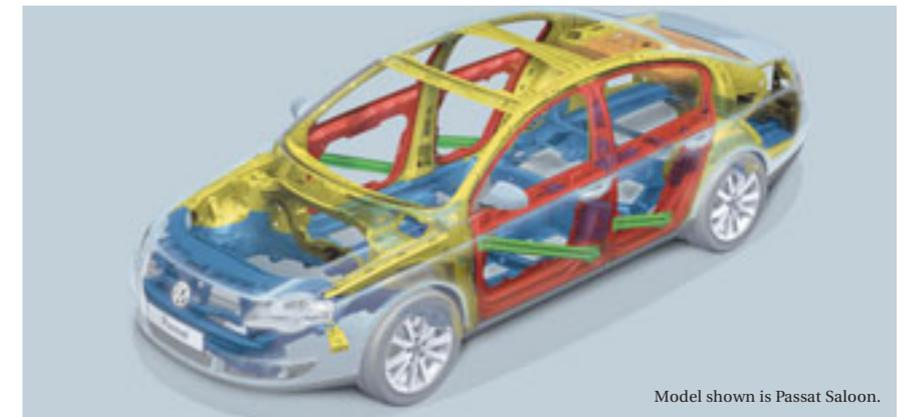

Model shown is Passat Saloon.

The bodies of the Passat and Passat Estate are formed from specially hardened components which possess high strength and excellent shaping characteristics. Thanks to the latest lightweight construction technology these bodies also offer optimal protection under heavy impact.

An important element of the Passat's safety philosophy concerns the protection of other road users, and involves a completely new passive safety concept. It starts with special protection zones located in the front body area and bumpers, reducing the risk of injury to cyclists and pedestrians. Occupants of the Passat are protected too, by a bodyshell equipped with crumple zones designed to absorb impact energy and protect the inner passenger compartment. Further protection is provided by a six airbag system, which includes driver's and front seat passenger's airbags, curtain airbags at the front and rear, and side impact airbags for the front, with rear available as an optional extra. In the event of an accident, WOKS (whiplash-optimised head restraints) on the front seats react within milliseconds, to help protect the head from injury and help to reduce whiplash. All this is supplemented by three-point automatic safety belts on all seats, an acoustic and optical warning for the driver's and front seat passenger's unfastened seat belts, and Volkswagen's innovative Isofix fittings to accommodate two child seats in the rear, providing maximum protection for children. As you can see, everything has been thought of to ensure maximum safety for all concerned, whether for other road users or for you and your passengers. You couldn't ask for more than that.

Paint



Black
Non-Metallic
A1
P



Iron Grey
Metallic
9H
P



Candy White
Non-Metallic
B4
P **BM** **RL** **R36**



Shadow Blue
Metallic
P6
P



Tornado Red
Non-Metallic
G2
P **RL** **R36**



Deep Black
Pearl Effect
2T
P **BM** **RL**



Glacier Blue
Metallic
3N
BM



Mocca Anthracite
Pearl Effect
3Q
P **BM** **RL**



Silver Leaf
Metallic
7B
P



Biscay Blue
Pearl Effect
7Q
R36



Reflex Silver
Metallic
8E
P **BM** **RL** **R36**



Island Grey
Pearl Effect
C9
P **BM** **RL**

P S, Highline, Highline Plus **BM** BlueMotion **RL** R Line **R36** R36

Standard Optional at extra cost

Please note: Screen technology does not allow for exact reproduction of the paint colours. For further details, please contact your Volkswagen retailer.



Diamond Black
Pearl Effect
Z4
R36

Upholstery

Black
 'Calino' cloth
 AR

Standard on S, S BlueMotion Technology, BlueMotion, R Line



Black/Grey
 'San Remo' microfibre sport seats
 with 'Vienna' leather* side bolsters
 IU

Optional on R36



Black
 'Vienna' leather* comfort seats
 XG

Standard on Highline, Highline BlueMotion Technology, Highline Plus, Highline Plus BlueMotion Technology

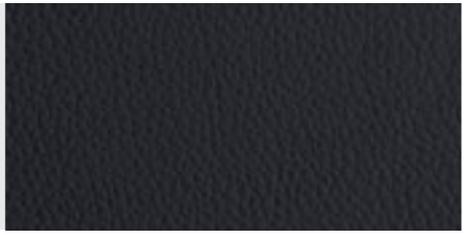

Latte Macchiato
 'San Remo' microfibre sport seats
 with 'Vienna' leather* side bolsters
 IV

Optional on R36

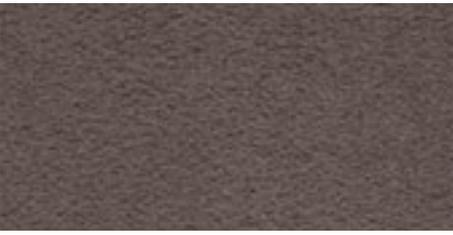

Grey
 'Vienna' leather* comfort seats
 XJ

Standard on Highline, Highline BlueMotion Technology, Highline Plus, Highline Plus BlueMotion Technology



Decorative inserts

Latte
 'Vienna' leather* comfort seats
 XK

Standard on Highline, Highline BlueMotion Technology, Highline Plus, Highline Plus BlueMotion Technology



Dark brushed Aluminium
 5MU

Standard on R36



Cornsilk Beige
 'Vienna' leather* comfort seats
 WE

Standard on Highline, Highline BlueMotion Technology, Highline Plus, Highline Plus BlueMotion Technology



Burr Walnut †
 PN5

Optional on Highline, Highline BlueMotion Technology, Highline Plus, Highline Plus BlueMotion Technology



Black/Grey
 'R36' cloth sports seats
 WU

Standard on R36



Engine spin
 PNA

Optional on R36



■ Standard ■ Optional at extra cost
 * Some parts of leather interior will contain artificial leather.

Please note: Screen technology does not allow for exact reproduction of the upholstery and decorative insert colours. For further details, please contact your Volkswagen retailer.
 † Optional only in conjunction with Latte or Cornsilk Beige upholstery.

Combinations

	S/S BlueMotion Technology	BlueMotion	R Line	Highline, Highline Bluemotion Technology Highline Plus, Highline Plus Bluemotion Technology	R36		Seat upholstery	Carpet	Dashboard	Black (A1)	Candy White (B4)	Tornado Red (G2)	Glacier Blue metallic (3N)*	Silver Leaf metallic (7B)*	Reflex Silver metallic (8E)*	Iron Grey metallic (9H)*	Shadow Blue metallic (P6)*	Deep Black pearl effect (2T)*	Mocca Anthracite pearl effect (3Q)*	Biscay Blue pearl effect (7Q)*	Island Grey pearl effect (C9)*	Diamond Black pearl effect (Z4)*	
'Calino' cloth Standard on S, S BlueMotion Technology	●					AR	Black	Black	Black/Black	●	●	●	-	●	●	●	●	●	●	●	-	●	-
'Calino' cloth Standard on BlueMotion		●				AR	Black	Black	Black/Black	-	●	-	●	-	●	-	-	-	●	●	-	●	-
'Calino' cloth Standard on R Line			●			AR	Black	Black	Black/Black	-	●	●	-	-	●	-	-	-	●	●	-	●	-
'Vienna' leather comfort seats† Standard on Highline, Highline BlueMotion Technology, Highline Plus, Highline Plus BlueMotion Technology				●		XG	Black	Black	Black/Black	●	●	●	-	●	●	●	●	●	●	●	-	●	-
				●		XJ	Grey	Black	Black/Grey	●	●	●	-	●	●	●	●	●	●	●	-	●	-
				●		XK	Latte	Black	Black/Latte	●	●	●	-	●	●	●	●	●	●	●	-	●	-
				●		WE	Cornsilk Beige	Cornsilk Beige	Black/Cornsilk Beige	●	-	●	-	-	-	●	●	●	●	●	-	●	-
'R36' cloth sports seats Standard on R36					●	WU	Black/Grey	Black	Black/Black	-	●	●	-	-	●	-	-	-	-	-	●	-	●
'San Remo' microfibre sports seats with 'Vienna' leather side bolsters* † Optional on R36					○	IU	Black/Grey	Black	Black/Black	-	○	○	-	-	○	-	-	-	-	-	○	-	○
					○	IV	Latte Machiatto	Black	Latte Machiatto	-	○	-	-	-	○	-	-	-	-	-	-	-	○

* Metallic and pearl effect paints and 'San Remo' upholstery are optional at extra cost.
† Some parts of leather interior will contain artificial leather.

● Standard ○ Optional at extra cost - Not available

Optional equipment



The Passat features Volkswagen's latest generation **voice activated RNS 510 DVD touch-screen navigation/radio system**. This DVD based navigation unit responds to spoken voice commands for navigation, CD and radio functions and not only delivers excellent sound quality but can also guide you effortlessly to your destination. A 6½" high resolution, touch-screen colour display shows a perspective (bird's-eye) view of your mapped route, in addition, traffic information (TMC), landmarks, intersection zoom, points of interest and a route list can all be viewed. As well as featuring the latest in processor technology, resulting in quick route calculations using all but the last two digits of a UK postcode, this sophisticated system features a 30 GB hard drive to buffer the navigation data as well as store the driver's favourite audio and video files (i.e. MP3, WMA, DVD video data files), the integrated DVD drive and SD (Secure Digital) card reader also allow the playback of such audio and video files. Completing the multimedia experience is the ability to connect an external multimedia device (e.g. iPod and MP3 player) via the AUX-in socket. Optional on all models.

Also available but not shown. **'Monsoon' and 'Dynaudio' soundpacks** ensure even greater sound quality for your Passat when specified with the RNS 510 DVD touch-screen navigation/radio system. 'Monsoon' optional on Highline, Highline BlueMotion Technology, Highline Plus and Highline Plus BlueMotion Technology models. 'Dynaudio' optional on R36 models.

Please note: RNS 510 DVD touch-screen navigation/radio system and RCD 510 touch-screen radio system cannot be specified in conjunction with each other. DVD playback will not function whilst the navigation system is in use, or the vehicle is in motion.



The **RCD 510 touch-screen radio system with integral dash-mounted MP3 compatible six CD autochanger and AUX-in socket** for connection to an external multimedia source (e.g. iPod and MP3 player) ensures hours of listening pleasure. Optional on all models except Highline Plus, Highline Plus BlueMotion Technology and R36.



The **2Zone electronic climate control air conditioning system**, with automatic air recirculation and indirect ventilation, uses electronic 2Zone temperature control to create an air conditioned environment individually suited to the driver and front seat passenger. Standard on R36 and optional on all other models.

Also available but not shown. **The DAB digital radio receiver** is available as an upgrade for your RCD 310 or RCD 510, enabling you to listen to all the digital stations available in crystal digital sound. Please note: DAB digital radio receiver and RNS 510 DVD touch-screen navigation/radio cannot be specified in conjunction with each other. Optional on all models except Highline Plus, Highline Plus BlueMotion Technology and R36.



Bluetooth telephone preparation* enables you to use your mobile phone without taking it out of your jacket pocket, thanks to Bluetooth (rSAP) connectivity. It is controlled via a separate keypad on the control panel. Optional on Highline and Highline BlueMotion Technology models.

* Only in conjunction with a multifunction steering wheel – phones must be compatible with rSAP (rSim Access Profile), please contact your retailer for phone compatibility. Must be ordered in conjunction with 2Zone electronic climate control on Highline models.



The front centre armrest features both an **AUX-in socket** and **Multi Device Interface (MDI)**, with the facility to connect, charge and store a compatible iPod or USB device. On S, S BlueMotion Technology and BlueMotion models this option also includes a front centre armrest. Optional on all models.

Multi Device Interface (MDI) and MP3 compatible 6 CD autochanger cannot be specified in conjunction with each other.

Optional equipment (continued)



Bi-Xenon headlights with automatic range adjustment, static corner lighting and dynamic curve lighting produce a much clearer, brighter light for both dipped and main beam, giving you a clearer view of the road ahead and helping you drive more safely, particularly on winding roads. Also included in this option are headlight washers which help keep headlights free from dirt, ensuring maximum visibility. Standard on R36 and optional on all other models except Passat Estate BlueMotion.



This specially designed **cargo management system** comprises two rails positioned on the left and right of the cargo area and four lashing eyelets. The rails can be used to individually fix straps and a telescopic rail into place using variable rod positions enabling secure stowage of luggage, whatever the size or shape. Optional on all Estate models except Passat Estate BlueMotion.



The front and rear parking sensors featuring **optical parking display** monitor the vehicle's distance from an obstacle, helping you manoeuvre in and out of parking bays. The radio system, or navigation/radio system display provides a visual representation, whilst an acoustic signal warns as an obstacle becomes closer. Standard on R36 and optional on all other models.

Also available but not shown. **Integrated child seats*** are integrated into the rear seat bench including seat belt tensioners for outer rear seats. A new design offers booster pillows integrated into the headrest mountings, giving your child even more side support. Please note that the integrated child seats are only available in conjunction with black upholstery or black leather. Optional on all models except R36.

* Not in conjunction with heated rear seats.

Alloy wheels



'Milwaukee' 7J x 16 alloy wheels with 215/55 R16 tyres. Standard on S models and not available as an option.



'Sarena' 7J x 16 alloy wheels with 205/55 R16 low rolling resistance tyres. Standard on BlueMotion models and not available as an option.



'Monte Carlo' 7½J x 17 alloy wheels with 235/45 R17 tyres. Standard on R Line models and not available as an option.



'Macau' 7½J x 17 alloy wheels with 235/45 R17 tyres. Standard on Highline, Highline BlueMotion Technology, Highline Plus, Highline Plus BlueMotion Technology models and not available as an option.



'Omanyt' 8J x 18 alloy wheels with 235/40 R18 tyres. Standard on R36 models. 19" 'Omanyt' 9J x 19 alloy wheels with 255/40 R19 tyres are also available as an option for the R36.



'Chicago' 8J x 18 with 235/40 R18 tyres. Optional on Highline, Highline BlueMotion Technology, Highline Plus and Highline Plus BlueMotion Technology models.



Volkswagen service for your peace of mind

The Volkswagen Warranty.

Three-year Warranty.

All Volkswagen Passats come with a three-year/60,000 miles warranty, which protects your car against the failure of most mechanical and electrical components due to manufacturing defects. This comprises a two-year manufacturer's warranty with unlimited mileage plus a further one-year/60,000 miles (whichever is soonest) Retailer Warranty. Should the mileage exceed 60,000 miles within the first two years, the manufacturer's two-year warranty will still be valid. If an additional warranty for subsequent years or higher mileage is desired, it may be purchased from an authorised Volkswagen retailer or repairer; however, this additional warranty must be purchased before the mileage reaches 60,000*. Full details of the three-year warranty are available from your authorised Volkswagen retailer or repairer.

* All warranty work must be completed by an authorised Volkswagen retailer or repairer.

Three-year Paint Warranty.

The paintwork of the Passat is covered against manufacturing defects for a period of three years. Naturally, the Passat must be cared for in compliance with the operating instructions which will be found in your vehicle handbook. Please consult your authorised Volkswagen retailer or repairer for full warranty details.

12-year Body Protection Warranty.

The internal body sections and panels of the Passats are covered against rusting through from the inside for 12 years. Naturally, the Passat must be cared for in compliance with the operating instructions. Please consult your authorised Volkswagen retailer or repairer for full warranty details.

Extended Warranty.

You may purchase additional protection from your authorised Volkswagen retailer or repairer, or contact 0870 9000 115.

Approved Accessories.

A comprehensive range of accessories from alloy wheels to carpet mats is available to complement the factory-fitted option list. Volkswagen approved accessories purchased from and fitted by your authorised Volkswagen retailer at the point of vehicle sale will also benefit from the three-year vehicle warranty.

Service Intervals.

Volkswagen are pleased to offer you a choice on how your Passat is serviced. The appropriate selection is entirely dependent on how the car is likely to be driven and its general use. To help you identify which type of service would be most suitable, please refer to the following guide.

The Time and Distance Service is recommended for vehicles that will cover less than 10,000 miles in 12 months and if the vehicle is likely to be used in the following way:

- Predominantly urban driving, short journeys with frequent cold starts.
- Activities regularly producing high engine loading, e.g. frequent hill climbs, driving with vehicle fully loaded and towing.
- Uneconomical driving style using high rpms with heavy acceleration and heavy braking.

The service intervals for the Time and Distance Service are as follows:

- Oil change service
Every 10,000 miles/1 year (whichever is soonest).
- Interval service
Every 20,000 miles/2 years (whichever is soonest).
- Inspection service
Every 40,000 miles/3 years (whichever is soonest).

The LongLife Service is recommended for vehicles with a daily mileage of more than 25 miles where the vehicle is driven regularly mainly on longer distance journeys. The vehicle is driven mainly at a constant speed with minimum vehicle and engine loading, minimal towing and driven in an economical manner.

With the LongLife Service the vehicle can cover anywhere between 10,000[†] and a maximum of 18,000[†] miles or 24 months (whichever is soonest) between oil changes. Inspection service is typically in the third year of ownership and thereafter every second year, for vehicles with an approximate annual mileage of 10,000 miles.

[†] Please note that mileages are approximate as the service indicator system uses kilometres as the distance measurement. Please consult your authorised Volkswagen retailer or repairer for advice and full details.

Volkswagen Insurance[‡].

We want you to start enjoying your new car from day one and thanks to Volkswagen Insurance complimentary seven day cover, you can. Call free on 0800 316 7892 (lines are open Monday to Friday 8 am - 9 pm and Saturday 9 am - 5 pm), provide a few details and a cover note will be sent to your retailer. They will then tax your car and you can drive it away.

Visit www.insurewithvolkswagen.co.uk for details of the full range of insurance products available. Here you can also get a quote for your annual car insurance and buy it online too. All of our insurance products are designed to ease the pain of making a claim.

[‡] Volkswagen Insurance is a trading name of Volkswagen Insurance Service (Great Britain) Limited, an appointed representative of Volkswagen Financial Services (UK) Limited, Brunswick Court, Yeomans Drive, Blakelands, Milton Keynes MK14 5LR. Registered in England number 2835230. Volkswagen Insurance is sold, underwritten and administered by Allianz Insurance plc registered in England number 84638. Registered office 57 Ladymead, Guildford, Surrey GU1 1DB. Volkswagen Financial Services (UK) Limited and Allianz Insurance plc are authorised and regulated by the Financial Services Authority. Volkswagen Financial Services (UK) Limited and Allianz Insurance plc are not part of the same corporate group.

Volkswagen Finance[±].

Volkswagen Finance specialises in providing funding solutions for Volkswagen drivers. Whether your Volkswagen is for private or business use, you can choose from a range of funding options.

- Solutions – a personal contract plan
- Hire purchase
- Lease purchase
- Finance lease
- Contract hire

With all Volkswagen Finance products you can choose a fixed-cost maintenance plan to help you budget for your servicing and maintenance costs.

No matter what finance product you choose, your local Volkswagen retailer will be able to provide you with a personalised quote that could meet your budget and vehicle needs.

[±] Volkswagen Finance is a trading name of Volkswagen Financial Services (UK) Limited. An offer of finance depends on certain conditions. Available to people over 18 in the UK only.

Volkswagen Roadside Assistance.

Every new car is registered for Volkswagen Roadside Assistance for one year. This provides vehicle home and roadside recovery in the unlikely event of a breakdown in the UK and Europe (subject to conditions). Volkswagen Roadside Assistance can also be purchased for subsequent years. For full details, please contact your authorised Volkswagen retailer or repairer.

Tax Free Sales.

For full details, please contact your authorised Volkswagen retailer.

CO₂ Emissions.

Increased weight of a vehicle, including higher trim levels and the addition of options will have a detrimental influence on the level of fuel consumption and CO₂ emissions produced.

The CO₂ and fuel consumption figures are obtained from tests on a representative vehicle of the type, conducted and approved in accordance with Council Directive 80/1268/EEC as amended by Directive 1999/100/EC (or later) on the approximation of the laws of the member states relating to the carbon dioxide emissions and the fuel consumption of motor vehicles.

Please Note:

Some illustrations in this brochure do not necessarily reflect UK specifications and may not be available. In particular, controls and some items of equipment are positioned differently for the UK.

The specifications contained in this brochure are for information purposes only and are subject to change. If you require any specific feature, you must consult your authorised Volkswagen retailer who is regularly updated with any change in specification. Please check model availability and full specification details with your authorised Volkswagen retailer prior to ordering.

Note: We would like to advise you that telephone calls to Volkswagen Customer Care may be monitored and recorded as part of our training and quality assurance processes. All our monitoring and recording processes meet Ofcom regulations.