



SLS AMG



Mercedes-Benz







The stuff that dreams are made of: black-and-white chequer

Right from the outset the Mercedes-Benz brand stood for sporting successes as well as comfort and luxury. The cars bearing the famous three-pointed star have put their performance to the test time and again – on the road and on the race track. The first vehicle bearing the name ‘Mercedes’ was delivered to its owner in 1900. It was the first modern motor car, boasted 35 hp and was a racing car. In 1952 the 300 SL, the legendary gull-wing model, first saw the light of day – and as the victorious winner it saw the chequered flags at the 24 Hours of Le Mans, the Bern Grand Prix and the Carrera Panamericana – in spectacular fashion.

In 1967 the AMG sports car manufactory was founded, and in 1971 it caused a sensation. At the 24 Hours the legendary ‘Red Sow’, a bright red 300 SEL 6.8 AMG, sped over the finishing line as the champion of its class – and into the history books. Countless victories in various different racing series followed – above all in the DTM. For some years now the engineers at Mercedes-AMG and Mercedes-Benz have been joining forces to develop the super sports car of modern times. They are striving for the maximum possible – with the same passion as their predecessors but using the technology of the future. The SLS AMG sees the black-and-white flag fall. Mission accomplished. A new legend has been created.



Can excitement be divided into chapters?
Let's see...

Inspiration

05 The SLS AMG

Facts

26 AMG

30 Drive system

36 Suspension

42 Safety

44 Equipment

64 Services

66 Dimensions and technical data





A second can accommodate more happiness than you might think

The SLS AMG was uncompromising even when it only existed in the engineers' and designers' minds. There was just one specification to adhere to: let your automotive fantasies run wild. The result is a super sports car with technology from the world of racing, a unique design and lashings of passion. And all this can be measured: in moments of happiness per second.



The wings to take you to undiscovered places

These gullwing doors hold the keys to hearts that beat faster when it comes to pure automotive design. They unleash previously unknown feelings of exhilaration. And that's before you've even hit the accelerator. The SLS AMG is a car that moves the soul.







Imagine a finishing line at the end of every journey

Exhilarating, powerful, breathtaking. In the SLS AMG you feel as though you're driving a racing car – only with a cup holder and automatic climate control. The AMG high performance assembly ensures impressive traction, the aluminium space frame low weight with the highest possible rigidity. The result: superb driving dynamics. And a winning feeling – over and over again.





Every paparazzo's nightmare

Anyone who'd been hoping to take a break between shift delays had better think again. The AMG Speedshift dual-clutch transmission in the SLS AMG shifts in less than 100 milliseconds – without any interruption to the power delivery. Acceleration like this calls for a rear aerofoil that ensures sufficient downforce. Helping you to get to your destination – or out of sight – faster.



Smile in less than 4 seconds

The SLS AMG races from 0 to 62 mph in 3.8 seconds with the world's most powerful standard-specification naturally-aspirated V8 engine, delivering an output of 571 hp (420 kW). Every V8 is hand built and signed by one single engineer. So if you thought emotions are hard to quantify, think again.





Its cruising altitude? 369 mm above the tarmac

The SLS AMG places its driver low and breathtakingly close to the tarmac. The long wheelbase, the dual wishbone suspension, the wide track – this supercar has a tight grip on every bend and every straight line. The only thing that might get carried away is you.





Not even time can overtake it

Built for tenths of seconds. And for eternity. The SLS AMG embodies timeless sports car design *par excellence*. From the striking front, the extremely long bonnet and the greenhouse positioned far back to the gently sloping tail end. In short: the SLS AMG isn't just ahead of the times – it redefines them.





Two wings make it an icon. The third prevents it from taking off

Even as the unique gullwing doors close above the driver, he can sense that he is about to become part of a legend. That this legend also sets new standards when it comes to performance and driving dynamics becomes clear at race track speeds, when the rear aerofoil is automatically extended for optimum downforce at the rear axle. It can also be activated by a button on the AMG Drive Unit – showing even at a standstill what the SLS AMG is made of.





A glimpse of a very promising future

The finest hand-sewn nappa leather. Solid metal, or carbon fibre as an option. The cabin invites the driver with beautiful materials that underline the handcrafted character of the SLS AMG – waiting to be enjoyed with each and every one of your senses.





The envy of racing drivers

The adrenaline, the testosterone - there's no denying the motor racing roots of the SLS. But we think you deserve a little more, like a cockpit full of driver-orientated luxuries, including the centrally-positioned COMAND multimedia system with navigation and 6-disc changer. It's the sort of thing a racing driver can only dream of.





A high-angle, close-up photograph of the interior of a Mercedes-AMG SLS. The image shows the driver's side, including the leather-upholstered seat with white stitching and an AMG logo on the side. The center console features a gear shifter and handbrake. The dashboard and steering wheel are also visible, showcasing the car's performance-oriented design. The background shows a view of the sky through the car's windows.

With so much excitement, no wonder you need to be strapped in

The stunning interior has plenty to keep you captivated: AMG sports seats with firm lateral support and high long-distance comfort, an AMG performance steering wheel and in the centre console the AMG Drive Unit with E-Select shift lever. Add to that the wing-shaped dashboard with four striking aviation-inspired ventilation outlets and you have every reason to buckle up and take command of the road.







Red is for 24-hour victory and pleasure day in, day out

Since the bright-red 300 SEL 6.8 AMG finished first at the legendary 24 Hours race in 1971, the colour red has seen many victorious reincarnations. This stunning Le Mans Red for the SLS AMG is one of nine exclusive colours, including innovative and sophisticated matt paints: *designo* Magno Alanite Grey and AMG Magno Monza Grey. And there's a newly-developed colour shade reminiscent of liquid silver: AMG Alubeam Silver. The driver can also choose from nine carefully coordinated appointments for the interior.



The Entertainment Package is fitted as standard. Under the bonnet

It growls, it hisses, it roars. The distinctive sound of the AMG high performance engine is a pleasure to listen to at any pitch. Should the driver prefer another symphony, the SLS AMG – fitted with the Bang & Olufsen BeoSound AMG sound system – will pamper even the most discerning listener.





Adrenaline – a resource you'll never run out of

Impressive on paper, overwhelming on tarmac. Working away in the SLS AMG is the world's most powerful standard-specification naturally-aspirated V8 engine – a claim this super sports car is only too happy to prove, as soon as you so much as tap the accelerator. And it delivers yet more: together with the AMG Speedshift and its Race Start function, the AMG 6.3-litre V8 front mid-engine equals exceptional performance. In other words: only the driver's pulse is faster.



A spectacle of nature. Unleashed by our engineers

Raging storms prove to man how powerless he is in the face of nature and how such forces know no bounds. But it is also in the nature of mankind to research precisely these limits, to push them and compete against them. The Mercedes-AMG engineers have succeeded in building an engine whose power does not shy away from comparison with that of the strongest forces of nature; if the SLS AMG were just a few mph faster, this would correspond to the highest level on the scale used in the USA to classify whirlwinds. The SLS AMG has gone head-to-head with the standards used to record the most awe-inspiring natural phenomena anywhere in the world – until there are virtually no more limits left to push. High time for the Mercedes-AMG developers to start looking for a new role model.



The technical explanation for dilated pupils

5,861 individual parts, distributed over a length of precisely 464 centimeters and a width of 194 centimeters, covered with up to 16.1 litres of paint. What do these numbers have to do with dilated pupils? Normally the pupil dilates in darkness, so that more light can fall on the retina. This is the only way the eye can take everything in. This is simply the body's reaction to a physical variable.

But a dilated pupil can also reflect an emotional reaction, as scientists discovered in the 1970s: when we are deeply moved and emotionally charged, the limbic system in the brain sends a stimulus to the eye – and the pupil widens. And that's why any future driver will have the designer's work to thank for the first physical reaction the SLS provokes – even before having the chance to experience the acceleration and centrifugal forces. When the gullwing doors swing open, the pupils dilate – a sign that the body is saying: "Give me more! I want to see every last detail."



We're now moving from the emotional to the technical section.
But you won't notice the difference





AMG

- 26 History
- 28 Philosophy

Drive system

- 30 Vehicle concept
- 32 AMG 6.3-litre V8 front mid-engine
- 34 AMG Speedshift DCT 7-speed sports transmission

Suspension

- 36 AMG sports suspension
- 38 Aluminium spaceframe body
- 40 Gullwing doors

Safety

- 42 Safety features

Equipment & appointments

- 44 Paintwork
- 48 Alloy wheels
- 52 AMG ceramic high-performance compound brake system
- 54 Interior equipment and appointments
- 56 Multimedia and navigation systems
- 57 Bang & Olufsen BeoSound AMG sound system
- 58 Standard equipment
- 60 Optional extras
- 62 AMG Performance Studio

Services

- 64 Mercedes-Benz Service

Facts & figures

- 66 Dimensions and technical data





42 years of AMG in two minutes. Our customers like life in the fast lane

Performance is AMG's special passion. So here are the most important facts about the company – in fast-forward mode.

AMG was founded in 1967 as a Swabian two-man engineering firm that built racing engines. The breakthrough came a mere four years later with the class victory at the Spa 24 Hours race in 1971. In 1976 the company moved to its current headquarters in Affalterbach near Ludwigsburg. Since 2005 AMG has been a 100% subsidiary of Daimler AG; today it employs nearly a thousand people and as Mercedes-AMG it is the performance brand of Mercedes-Benz Cars. Mercedes-AMG develops exclusive high-performance models including one-offs which are manufactured in accordance with individual customer requirements. The customers' powers of imagination are what drives the company in its relentless aim to be better and better and continue implementing new, exciting projects.

The Mona Lisa wasn't painted by five masters either

An engine created by Mercedes-AMG is the product of many clever people's work. And the work of one clever person who is very good with their hands. According to the 'one man, one engine' principle, one single Mercedes-AMG technician assembles one single engine from start to finish. He is solely responsible for all the individual steps - from installing the crankshaft and the wiring to pouring in the engine oil. He meticulously implements the Mercedes-Benz quality criteria. And confirms this with his signature on the engine badge. Just like any true master signs a great work of art.



Handcrafted
by

Robert Heller

**Mercedes-AMG
Affalterbach, Germany**





We made an exception with this car and paid our engineers to daydream

When do any engineers normally get the chance to live out their automotive fantasies without any restrictions? When they started work the Mercedes-AMG developers sat down with that famous blank sheet of paper, yet ended up taking advantage of this unique opportunity in a record time of just 37 months. The result: a revolutionary super sports car whose every detail has been designed with driving dynamics in mind. The high-performance AMG engine, just 205 kg when dry, was installed as a front mid-engine – and sits as low as possible in the vehicle. The drive system with a rear-wheel-drive transaxle helps achieve near-perfect weight distribution between the front and rear axle. And the body was constructed around these key components – as an ultra-light yet extraordinarily rigid structure whose gross weight has been significantly reduced thanks to intelligent optimisation. Pure driving dynamics – better than our engineers could ever have imagined in their wildest dreams.



Dry sump lubrication. It's our favourite turn of phrase in the entire brochure

The SLS AMG's design engineers were able to position the engine as low as possible behind the front axle by employing an unusual type of lubrication technology in order to dispense with the sump that is usually located beneath the engine. In its place an external oil tank and several pumps supply the engine with lubricant – even during high lateral acceleration.

We could fill pages and pages writing about the other performance-enhancing measures that were implemented, so here are the most important ones in a nutshell: a newly developed magnesium intake manifold with precisely matched resonance tube lengths for optimum cylinder flow, the use of exhaust headers, significantly lighter forged pistons plus bucket tappets for a rigid valve train that improves power and torque output. The rest is written all over the faces of euphoric drivers: 6.3-litre V8, 571 hp (420 kW), 650 Nm torque, acceleration from 0 to 62 mph in 3.8 seconds, top speed 197 mph. Figures can be such fun!

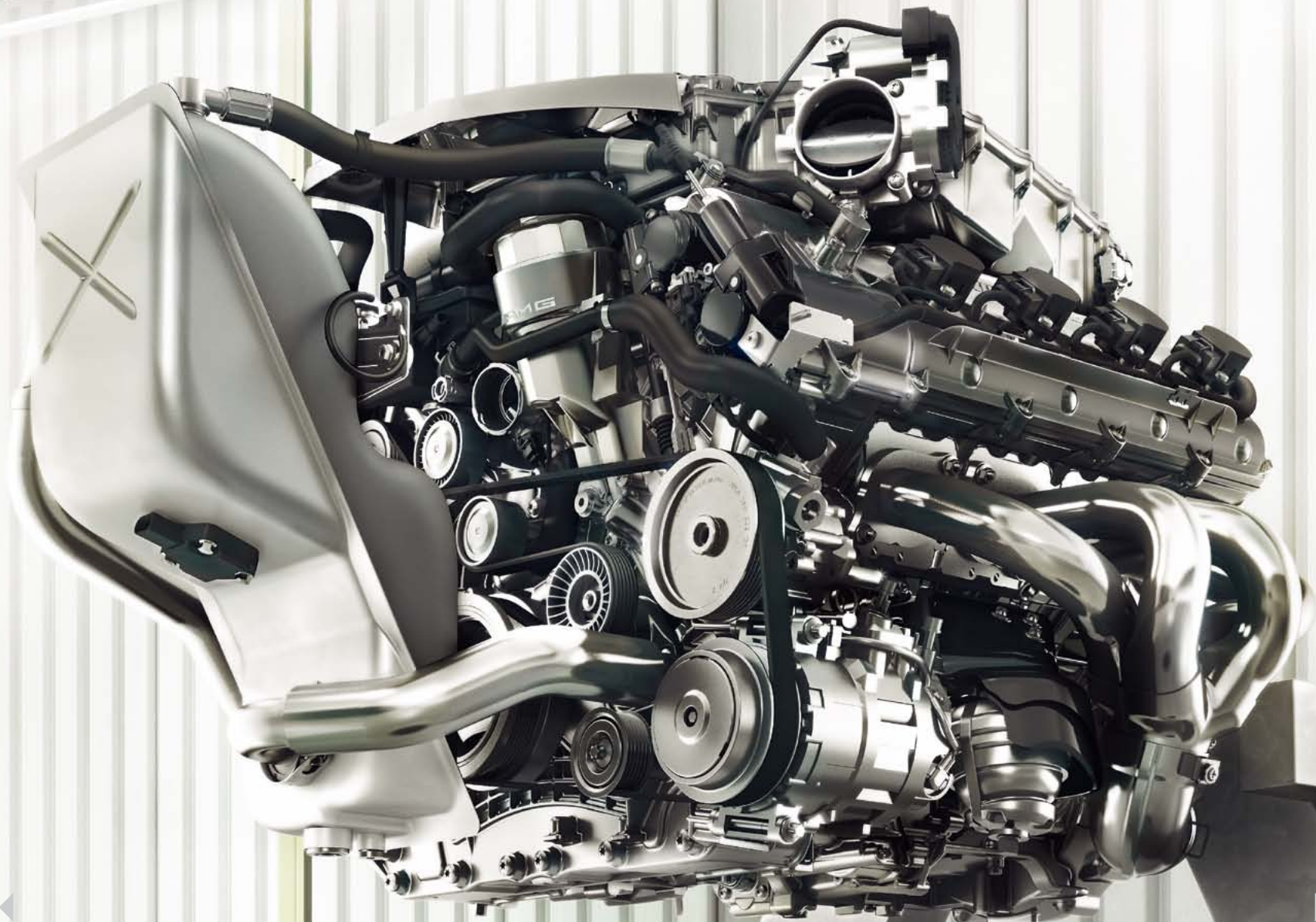

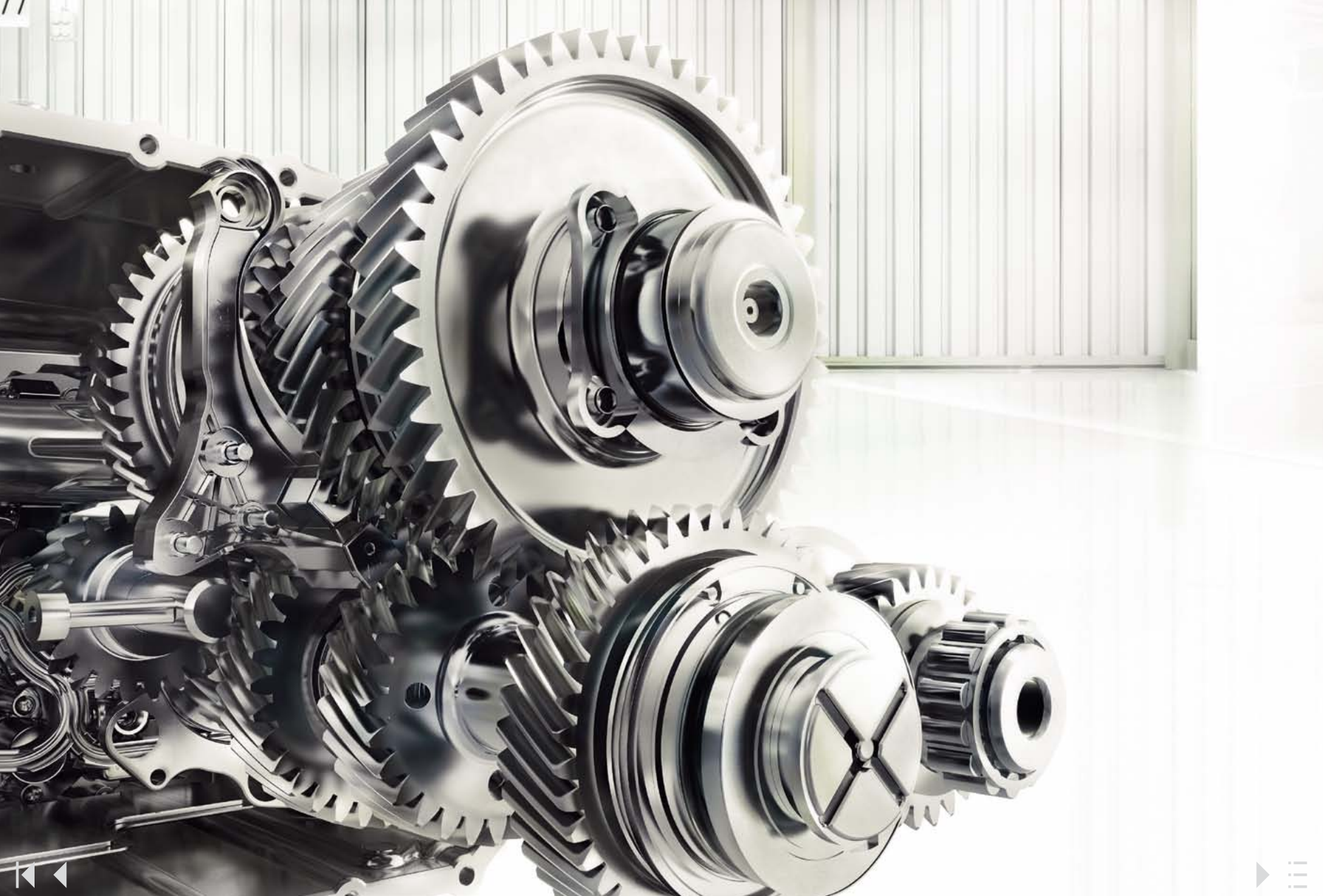



Cut a fine figure on the race track. In designer sports gear

With this much engine output, every gear is a revelation. The new AMG Speedshift DCT 7-speed sports transmission with an integral rear axle differential lock is in control here. The dual-clutch transmission's construction principle comes from the world of motorsport: it consists of two automated dividing gears, each with one clutch. When changing gear, one clutch closes whilst the other one opens simultaneously, so that there is no interruption to power delivery during shifting. Incidentally, all this happens in less than a hundred milliseconds – just as fast as a racing driver. The driver can choose from four transmission modes: 'C' (Controlled Efficiency), 'S' (Sport), 'S+' (Sport plus) and 'M' (Manual). The Race Start function facilitates maximum acceleration from standstill. So if you should ever find yourself unable to resist a race track, there's plenty of scope for challenging the laws of physics.





Race-track quality roadholding

Aluminium, steel and motorsport know-how. These are the components that make the SLS AMG's suspension so uncompromising. The technical details: dual wishbones with a tie rod, independent wheel and spring location and purpose-developed spring struts. These are tuned so as to increase camber and track-holding rigidity considerably, while a long wheelbase ensures straight-line stability and the wide track width more grip on bends. All in all: roadholding you can feel every second of the journey. It's the aerofoil, however, which improves downforce even more: at race track speeds it extends automatically. Anyone wishing to inject yet more sportiness can select the AMG performance suspension, available by special order. With its tauter tuning of springs and dampers it adds up to optimised lateral dynamics ideal for the race track.



When we build sports cars we try our best to lose. Weight, of course

Less is not more – it's faster: in order to achieve the lowest weight possible, the designers were consistent in their use of aluminium for the bodyshell of the SLS AMG. The entire aluminium space frame weighs just 241 kg. In order to achieve this weight and to render the structure as stable as possible, the engineers optimised the distribution of forces in the structure again and again. Precisely calculated aluminium cast parts are positioned in places which bear the brunt of high forces. A mere four per cent of the bodyshell is still made of steel – specifically to strengthen crash protection zones. So much stability and safety but so little weight – this could well be a record. And anyone for whom the car still isn't light enough can reduce its weight even further with numerous optional extras: with considerably lighter AMG sports bucket seats, ceramic brake discs, forged wheels or with the extensive use of carbon fibre trim parts.

6





D S LS 6397





The only door that doesn't take up any room when it opens – it *creates* room

It's fantastic that the SLS AMG is so super sporty. It's even more fantastic that its driver doesn't have to be. Because the gullwing doors make getting in and out really easy: with an entrance height of 45 cm, a distance between the open door and the ground of 1.50 metres and an opening angle of 70°. It's hard to believe the gullwing doors extend outwards no more than 36.3 cm when opening – much less than a normal car door. And it goes without saying that they can be opened fully in every conventional garage. The driver senses at first glance just how special these gullwing doors are. And so that absolutely nothing impairs the look of the perfect lines, the door handles have been fully integrated, only folding out when they are unlocked.

High performance is our goal when it comes to safety, too

The three-pointed star on the SLS AMG's radiator is a sure sign that the weight-reducing measures aren't at the expense of hallmark Mercedes-Benz safety. On the contrary. The basis of the safety concept is the stable aluminium space frame which is reinforced with steel where occupant safety demands. Also responsible for the high level of safety enjoyed by the driver and passenger are belt tensioners and belt force limiters. And there are no less than eight airbags in total: two adaptive airbags in the front area and two each in the side, head and knee area.

There are also numerous electronic driver assistance systems taking care of active safety. And by the way, the SLS AMG is also streets ahead where safety in Formula 1 is concerned – as the Official F1™ Safety Car, tested and serviced by the AMG Performance Studio's specialists.





ESD



Nine colours. From Silver Arrow to Black Beauty

The SLS AMG looks racier than the competition even when stationary. This is thanks to nine exciting paint colours, including the classic sports car colours silver, red and black. But we wouldn't be AMG if there weren't a healthy helping of know-how in the paints – take the AMG Alubeam Silver variant, for instance, whose surface shines like liquid metal, brought to life through light reflections. The secret to this process – which is a unique one worldwide – is held by colour particles that are a mere 30–50 nanometres in size. Quite different, though equally fascinating, are the Magno matt paints. They set off the lines and shape of the body magnificently, giving the SLS AMG a velvety, sensuous outer skin.

Standard



Obsidian Black



Iridium Silver

designo*designo* Magno Allanite Grey^{1,2}*designo* Mystic White 2¹

Paintwork

Just for a change the SLS AMG makes something weigh heavily on your mind: choosing from its nine paint colours. There are two metallic paints as standard: Iridium Silver and Obsidian Black. As an optional extra you can choose between two *designo* paints – *designo* Magno Allanite Grey and *designo* Mystic White 2 – plus five other exclusive AMG paints, some of which are named after the most famous race tracks in motorsport history – Monza, Le Mans, Imola and Daytona.

AMG



AMG Alubeam Silver¹



AMG Magno Monza Grey^{1,2}



AMG Le Mans Red¹



AMG Imola Grey¹



AMG Daytona Blue¹

¹Additional cost option. Please see price list for further details

²Magno matt paint finishes require special care. Please ask your Retailer for further details







Yet another reason to bow down. The alloy wheels

It's not just the body – the wheels and tyres also blend high tech and design to impressive effect. AMG alloy wheels, produced using the flow-forming process, bring increased driving dynamics and suspension comfort. They are weight-optimised – as are the forged wheels that are also available – and, with their striking, puristic design, blend harmoniously into the top athlete's super-fit look. They wear tyres developed exclusively for the SLS AMG – for outstandingly high grip. Their air pressure is constantly monitored and the value for each individual wheel displayed in the cockpit. But first and foremost: the finer the wheels the better they suit the SLS AMG.





Standard equipment
AMG 7-spoke alloy wheels



Optional extra
AMG 5-twin-spoke alloy wheels



Optional extra
AMG 10-spoke forged wheels

Pity you only ever get a fleeting glance of them as the car speeds by

There are three different wheel designs in Titanium Grey and 19"/20" combination available for the SLS AMG. High-shine AMG 7-spoke alloy wheels are fitted as standard. Also available as an option are high-shine AMG 5-twin-spoke alloy wheels or the weight-optimised, polished AMG 10-spoke forged wheels. Every wheel brings its own interpretation of the supersport theme, but what they all have in common is a design that allows you to look through the spokes so you have an excellent view of the large AMG high-performance brakes. For this, too, is certainly a sight worth seeing.





Optional extra
AMG high-performance ceramic composite brakes

They won't want to hear this in Meissen, but this is how to process ceramics

The newly developed AMG high-performance ceramic composite brakes are available as an option for motorsport-style braking power. Its discs are characterised by their extreme hardness, as they are made of ceramics reinforced with carbon fibre. This reduces the weight of the brake discs by 40%, improving steering behaviour thanks to lower unsprung mass, while also facilitating shorter braking distances, higher fatigue strength and a longer life. At a standstill you can recognise the ceramic brake through the specially painted brake calipers. In the eyes of the AMG master craftsmen, not even a piece of Meissen porcelain could beat this for looks.





A detailed view of the interior of a Mercedes-AMG SLS. The image shows the driver's side, including the steering wheel with the Mercedes logo, the dashboard with two circular gauges, and the front passenger seat. The seats are upholstered in black leather with white top-stitching. The center console has a carbon fiber texture. The door panel features a circular air vent with the Mercedes logo. The overall aesthetic is sporty and luxurious.

Rarely can a co-pilot have clung onto such exquisite appointments

The driver might not get much of the landscape flying past outside – but the fine interior certainly makes up for this. The AMG sports seats are made of hand-sewn black nappa leather and many of the interiors boast contrasting top-stitching. The roof lining and the A- and C-pillar trim are in Anthracite-coloured Alcantara®, the footwell and rear panel are covered with a black velour carpet. So it may well have absolutely nothing to do with driving dynamics if the co-driver comes over all touchy-feely.



designo leather

801

Black

designo Exclusive leather, single-tone

501

Black



505

Sand



507

Classic Red



515

Porcelain

Colours and materials

The AMG sports seats' backrests consist of high-strength magnesium, with good lateral support – even when the going gets sporty – courtesy of deeply contoured side bolsters. That's the inner values taken care of. Craftsmanship and love of detail can be seen and felt on the exterior of the seats, too. This applies to the standard-fit appointments in Black nappa leather and the optional extras in equal measure. The latter are in *designo* Exclusive leather and come as a single- or two-tone variant or natural leather with a woven leather insert. You might spend much of your time driving against the clock, but you should take all the time you need for this difficult decision.

designo Exclusive leather, two-tone¹



555

Sand/Black



557

Classic Red/Black



565

Porcelain/Black

Natural/woven leather



204

designo Exclusive leather in Light Brown

¹Includes lower dashboard section, lower door panels, sides of centre console and armrests in interior colour. Sun visors are lined in Alcantara®, upper dashboard section and upper door panels in Black nappa leather





Standard equipment
Central control panel for COMAND multimedia system



Standard equipment
7-inch TFT colour screen for displaying high-resolution maps

Multimedia system and navigation

The latest telematics-generation COMAND multimedia system is fitted as standard on board the SLS AMG. It includes a 7-inch TFT colour display, six speakers, a DVD drive for audio and video, a 6-disc CD/DVD changer, a music register with a 4-GB memory for digital music, a Bluetooth® interface and a Media Interface for the connection of external media devices. Navigation is via the hard disc and features particularly high-resolution map display. The colour display also shows pictures from the optional reversing camera. And so that you can concentrate fully on driving, the COMAND multimedia system with Linguatronic can be controlled via spoken instructions.



Optional equipment
Bang & Olufsen BeoSound AMG sound system:
250-watt subwoofer



Bang & Olufsen BeoSound AMG sound system:
the illuminated tweeter lens

Bang & Olufsen BeoSound AMG sound system

Looks like the speed record for concert halls has been broken. A high-end surround sound system developed together with Bang & Olufsen specially for the SLS AMG is available as an optional extra. Its 11 high-performance speakers, with a total of 1,000 watts, create astounding acoustics and the two illuminated tweeter lenses are a feast for the eyes. The driver can choose between the 'Reference' high-end studio sound and an expansive surround sound, and the sound fields can even be precisely directed towards the seats with the aid of the digital sound processor (DSP). Everything you need for pristine sound and a perfect listening experience.



The AMG Drive Unit with E-Select lever and Keyless-Go start function



AMG instrument cluster with 7-LED upshift indicator in manual mode



AMG heated sports seats, with memories, in *designo* nappa leather



Body-coloured door sills with embossed AMG lettering

Standard equipment | Selection

Fitted as standard in the SLS AMG is the aluminium 'Silver Shadow' centre console with the AMG Drive Unit, the AMG E-Select lever and the Keyless-Go start function. Also on board are the luxury automatic climate control, the Parktronic parking aid, the COMAND multimedia system with Linguatronic, 6-disc changer and the AMG instrument cluster with white backlit round dials, an upshift indicator with seven LEDs when in manual mode, silver-coloured dials and red needles. Standard-fit features also include heated AMG sports seats, with memories, in hand-sewn black nappa leather with contrasting top-stitching.



Bi-xenon front headlamps with integrated LED daytime driving lights



Screw-on solid metal fuel filler cap



Rear bumper with fully integrated tailpipes

Yet more standard equipment comes in the form of the AMG performance steering wheel with a dynamic 3-spoke design, silver-coloured aluminium gear shift paddles and a solid metal insert, the roof liner and A- and C-pillar trim in Anthracite-coloured Alcantara® and door sill panels in the vehicle colour, featuring a Black nappa leather insert and embossed AMG lettering. And that was just the interior. The standard equipment for the exterior includes bi-xenon headlamps with integrated LED daytime driving lights, a solid metal screw-on fuel filler cap, 19"/20" AMG 7-spoke alloy wheels and the rear bumper with integrated tailpipes.



AMG performance steering wheel in nappa leather/Alcantara®



AMG carbon fibre trim elements with genuine carbon fibre insert for the centre console



AMG carbon fibre engine compartment cover



AMG Interior Carbon Fibre Package

Optional extras | Selection

Even the utmost in enjoyment can become even more enjoyable. The optional extras offer you a choice of single- or two-tone *designo* Exclusive leather appointment variants, or you can opt for a natural/woven leather combination. Also available as options are the AMG performance steering wheel with Alcantara® inserts, AMG carbon fibre trim elements – with a genuine carbon fibre insert for the centre console and the door trim strips – or the AMG Interior Carbon Fibre Package with additional carbon fibre door sill panels and carbon fibre seat linings.





AMG Interior Carbon Fibre Package, seat lining



AMG sports bucket seats



AMG carbon fibre exterior mirrors

Also available as optional extras: an AMG carbon fibre engine compartment cover, AMG carbon fibre exterior mirrors, plus lightweight AMG sports bucket seats for perfect lateral support and maximum sportiness.¹

¹AMG sports bucket seats do not include heating or memory functions

As far as we're concerned there's no possible or impossible. Only minor and major challenges

The AMG Performance Studio was founded in 2006 to make your AMG Mercedes even more individual and even sportier. The thing that really makes our employees' day? When they have to say "I've never come across that before!" when met with a particularly demanding customer requirement, before they set about turning the idea into reality with zeal. Because our highly motivated specialists regard every request for particular colours or materials, for extravagant appointments or yet more dynamism as a special challenge to which they are only too glad to rise as they fulfil it with passion and meticulous precision.



Services

Mercedes-Benz Museum. More than 120 years of automotive history in one place – this is what awaits you at the Mercedes-Benz Museum in Stuttgart. Experience the unique excitement, and embark upon a thrilling journey through time. Housed inside an architecturally impressive building, over 1,500 exhibits on nine levels give you an insight into the unique tradition and powers of innovation of the Mercedes-Benz brand. Plus you can see the world's first two cars in the shape of the Benz patent motor car and the Daimler motorised carriage – both from the year 1886. Two linked circuits take you from the beginnings of the car, past a series of unforgettable classics, through over 100 years of motor-racing history and, finally, on to a glimpse of what the future holds – in an area covering a total of 16,500 square metres. Enjoy the unique brand experience! We look forward to your visit. Further information is available at www.mercedes-benz.com/museum

Mercedes-Benz World at Brooklands. Celebrate the story of Mercedes-Benz and you'll celebrate the story of motoring itself at Mercedes-Benz World in Surrey. A World of experiences. A World of discoveries. A World you will love to explore. Discover Mercedes-Benz racing heritage, its connections to the famous Brooklands circuit and legendary drivers. View, touch and sit in every car from the Mercedes-Benz range and encounter automotive legends like the 'Gullwing' in the UK's largest Mercedes-Benz showcase. Then set your pulse racing by booking one of our thrilling Driving Experiences. Enjoy AMG performance on the purpose-built Handling Circuits or Wet Skid Circle, an axle-twisting Off-Road adventure, or treat your kids to their own drive in an A-Class if they are over 1.5 metres tall. For more interactive action take a virtual journey along the production line in 'Build', or put your brain to the test in 'Solve'.

Relax and refuel in Café 1886, or for a gourmet treat enjoy the first-class menu and elegant surroundings of the Gullwing Restaurant. Finally, extend your visit with a short stroll to Brooklands Museum to see their collection of classic cars, aviation exhibitions – and the legendary Concorde. For more information visit www.mercedes-benzworld.co.uk

Roadside Assistance. Rest assured that should you ever need help, Mercedes-Benz Roadside Assistance is there for you. In the unlikely event of a technical breakdown¹ or starting problem anywhere in Europe, you can rely on the Mercedes-Benz Roadside Assistance Team – anywhere in Europe. Simply phone our Customer Assistance Centre on 00800 1 777 7777,² where our specialists will organise assistance for you. Mercedes-Benz will also assist you in the event of a minor mishap preventing you from driving your vehicle.³ Whether you lose your key, run out of fuel or if your vehicle is damaged due to an accident or vandalism, Mercedes-Benz ensures that you still reach your destination. Often the problem can be rectified on the spot, but if this is not possible, we will naturally ensure that your vehicle is taken to the nearest Mercedes-Benz Official Workshop to get you back on the road as quickly as possible.

Interactive Owner's Manual. You can familiarise yourself with your desired model online by taking our interactive tour. Climb on board and use the simulators to get to know your dream car. You can experience key functions in detail, take a close look at the inner workings of the car or find out about the benefits of each model. For further details, go to www.mercedes-benz.co.uk/slsamgmanual

¹ Technical breakdown cover is initially valid for your vehicle for four years from the date of first registration. This can be extended from the fifth year, up to a maximum of 30 years, on completion of each scheduled maintenance service, providing that this service is carried out by a Mercedes-Benz Official Workshop

² In non-affiliated European countries: +49 69 9530 7277

³ This cover can be retained from the fifth year. Your Mercedes-Benz Official Workshop will provide details of how to renew this cover once your initial four year term has expired

Dimensions¹ and technical data

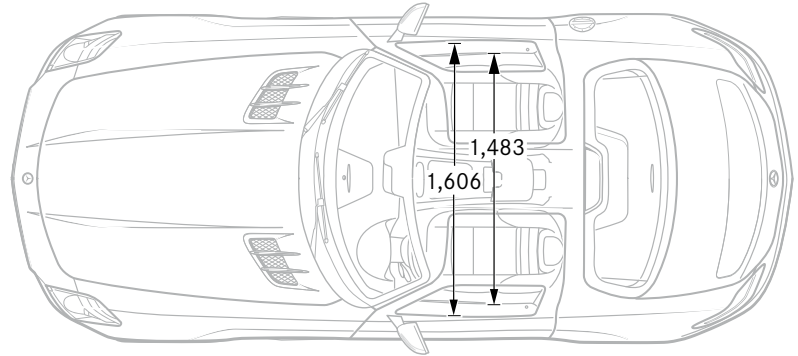
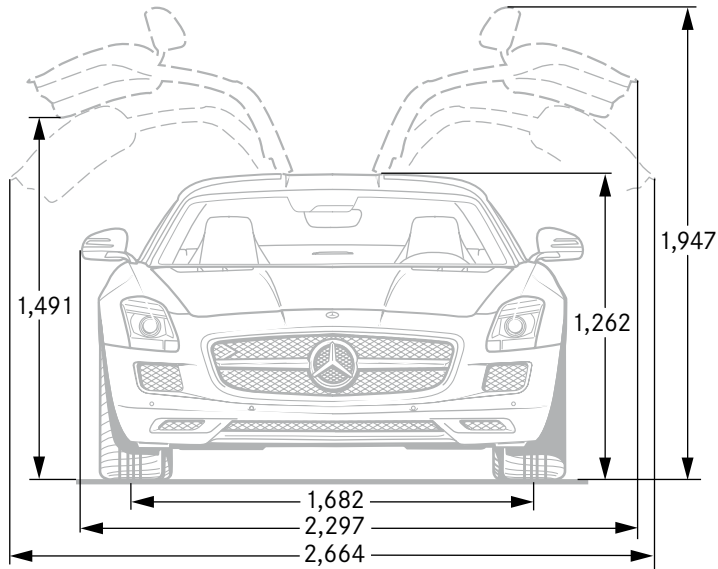

Arrangement/number of cylinders	V8
Total displacement – cc	6,208
Rated output ² – hp (kW) at rpm	571 (420)/6,800
Rated torque ² – Nm at rpm	650/4,750

Acceleration from 0–62 mph – sec	3.8
Top speed – mph	197
Fuel	Super Plus
CO ₂ emissions ³ , combined – g/km	308/EU5 emissions standard

¹ All measurements in millimetres. The dimensions shown are mean values and apply to standard-specification, unladen vehicles

² Figures in accordance with Directive 80/1269/EEC in the currently applicable version

³ The figures shown have been calculated in accordance with the prescribed measuring process (Directive 80/1268/EEC in the currently applicable version). The figures are not based on an individual vehicle model and do not constitute part of the product offer; they are provided solely for purposes of comparison between vehicle models

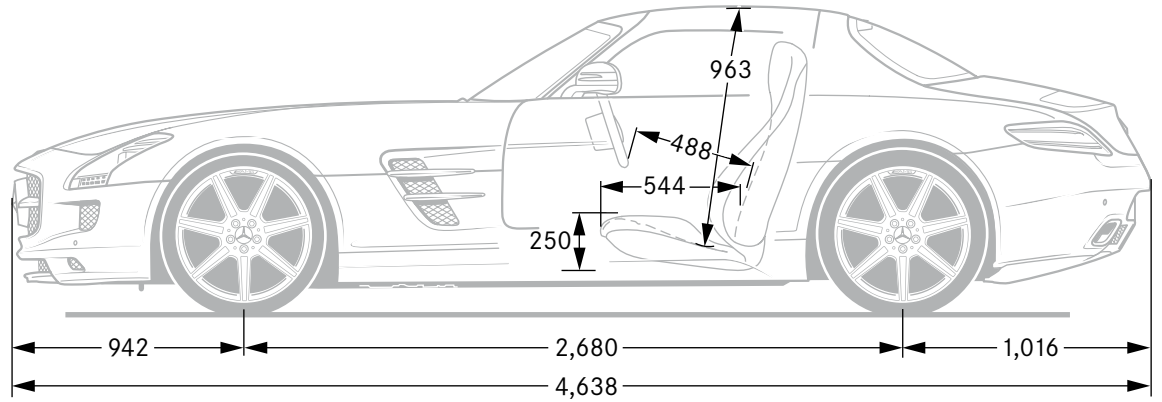
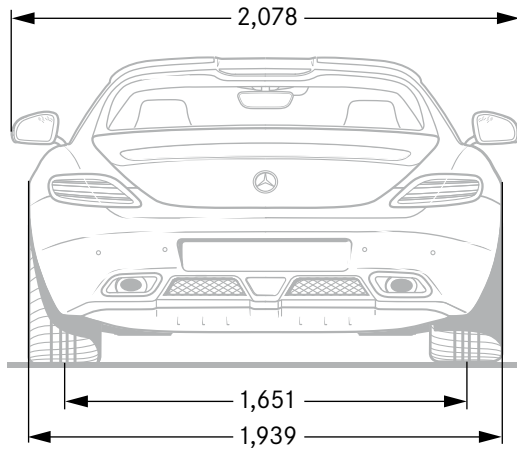

Fuel consumption³ – mpg

urban	14.2
extra-urban	30.4
combined	21.4

Front tyre size

265/35 R 19

Rear tyre size

295/30 R 20

Kerb weight⁴ – kg

1,620

Perm. GVW – kg

1,935

⁴Figures according to Directive 92/21/EC, version 95/48/EC (kerb weight with fuel tank 90% full, driver, 68 kg, and luggage, 7 kg) for standard-specification vehicles. Optional extras and accessories will generally increase this figure and reduce the payload capacity accordingly

Take-back of end-of-life vehicles. Coming full circle. At the end of its long life, you can return your SLS AMG to us for environment-friendly disposal in accordance with the EC End-Of-Life Vehicle Directive.¹ But that day lies a long way off.

¹Applies in accordance with national regulations to vehicles up to 3.5 tonnes gross weight. The SLS AMG has met the statutory regulations governing the suitability of the vehicle's design for reuse and recycling for a number of years now. A network of vehicle take-back depots and dismantlers has been established which will process your vehicle in an environment-friendly manner. The ways in which both vehicles and parts can be recovered are subject to ongoing development and improvement. Consequently, the SLS AMG will be able to comply with any future increases in the recycling quota within the stipulated time limits. Further information is available at www.mercedes-benz.co.uk or by calling 0808 156 6606.

Please note: this online version of the printed brochure may contain abridged copy or other content changes. The manufacturer reserves the right to make changes to the design, form, colour and specification during the delivery period, provided these changes, while taking into account the interests of the vendor, can be deemed reasonable with respect to the purchaser. Where the vendor or the manufacturer uses symbols or numbers to describe an order or the subject of an order, no rights may be derived solely from these. The illustrations may show accessories and items of optional equipment which are not part of standard specification. Colours may differ slightly from those shown. This brochure provides a general indication of the range of models, features, optional extras and/or colours available in various countries. Some of the models, features, optional extras and/or colours shown may not be available in your country or may only be available in a different specification. Additionally, some models, features, optional extras and/or colours may only be available in combination with others. For current and more specific information in relation to the range of models, features, optional extras and/or colours available in your country, and their pricing, you should contact your nearest authorised Mercedes-Benz Retailer. E&OE. www.mercedes-benz.co.uk