



THE ALL-NEW VOLVO S60



THERE'S MORE TO LIFE THAN A VOLVO. THERE'S THE COURAGE TO DARE. THERE'S THE CURIOSITY TO EXPLORE. THERE'S THE THIRST FOR PASSION AND THE HUNGER FOR EXCITEMENT. THERE'S THE

HUNT FOR EXPERIENCES THAT ARE NEW AND UNIQUE. EMOTIONS TAKE US TO THRILLING PLACES. SO DOES THE STUNNING ALL-NEW VOLVO S60. THAT'S WHY YOU DRIVE ONE.





Sexy. Volvo. Same sentence.

Introducing the first Volvo to freely inspire the use of adjectives and superlatives rarely mentioned by those not on the payroll. A masterwork of automotive design, the all-new Volvo S60 is so beautiful, we suppose pedestrians could be stunned when they first see it, so we invented a safety system for them. A world first. But make no mistake; this is a driver's car. It moves like no Volvo before. And it can stop itself at any speed – even at speeds as high as 200 km/h. Too sexy to be the safest car ever? We can live with that.



Built to inspire impure thoughts
of punctuality.

With sports seats standard, sports chassis standard, and optional speed-dependent progressive power steering that drivers can set, being on time could easily start being more fun than it should be.



Downright shameless with the affection it shows for curves.

Who knew an anti-skid system could be so pro-fun? The advanced chassis developed for the all-new Volvo S60 makes it clear: this is no ordinary Volvo. And utilising new innovative technology, we have further refined Volvo's stability enhancing DSTC system to help drivers better realise their intentions – with more assertion, efficiency and dare we say, more pure driving enjoyment. Advanced Stability Control, for example, is a new function that monitors the car's behaviour with high precision to further enhance stability in sharp cornering and rapid lateral movements. Torque Vectoring is another new feature that helps reduce understeer in fast bends. It also improves acceleration when trying to get up-to-speed while merging with faster moving traffic on a main road. And if you're in for even more dynamics, just activate the DSTC Sport Mode in the on-board menu system. So how fun can you really have in the all-new Volvo S60? Well, that's up to you to decide.

304 horsepower and whiplash protection. A match made in Sweden.

Engineered into every Volvo is the power to avoid trouble and the structure to minimise harm. Volvo's unique Whiplash Protection System built into the front sports seats is but one example. The engine in your Volvo is also an excellent representative of this philosophy. Fact is, every Volvo engine is built to do more with less: respond instantly, with plenty of torque, throughout its entire rev range and do so using less fuel.

The range of 4, 5 and 6-cylinder petrol or diesel variants available for your all-new Volvo S60 includes the top-of-the-line 3.0 litre turbo-charged petrol engine. With 304 horsepower, twin scroll turbo technology, ultra-low emissions plus All Wheel Drive, acceleration is instant – as is the gratification. The top-of-the-line 2.4 litre five-cylinder diesel – with sequential twin turbochargers, 420 Nm of supreme torque, and a maintenance-free particle filter – also offers a perfect match of high performance and peace of mind.





The first Volvo equipped with envy and jealousy standard.

The all-new Volvo S60 makes no apologies for this drivers-oriented interior. The driver's seat is the world's first throne to come with extra lateral-g support and it's own 3-spoke steering wheel. Long may you reign. In addition, the centre console is angled to favour the driver's side and features Volvo's new driver control interface. This intuitive computer command system uses the built-in screen and a scroll wheel selector on the steering wheel to make it easy to personalise settings and get the most from all of your onboard technology. Of course, passengers are made as comfortable as possible with easy access to (drool) cup holders and more.

Not the first Swedish beauty
that likes to avoid people.
But certainly the first car that can.

It is not likely, yet still possible, for a pedestrian to ignore your beautiful all-new Volvo S60 and step into your path. Fortunately, the world's first pedestrian avoidance technology is available, so happy ending goes here.

Using a digital camera and radar to constantly scan the road ahead, shapes identified as people at risk will trigger a warning. More importantly, the system will employ full brake force to stop your vehicle – if you don't. Every car should have this technology available, but there's only one car that does; the all-new Volvo S60. Our experts call it Collision Warning with Full Auto Brake and Pedestrian Detection, but you can simply call it another Volvo safety world-first.



What we know:
A rear-end collision is not the best way
to meet people.

With a goal to automatically eliminate the most common (and embarrassing) type of accident – the low-speed (below 30 km/h) rear-end collision – Volvo created City Safety. This remarkable technology – standard with the all-new Volvo S60 – uses a closing-velocity laser sensor that tracks the car immediately ahead of you and constantly calculates how much braking force is needed to come to a full-stop before meeting them unintentionally. If the system senses an imminent exchange of personal information and insurance forms, it will automatically brake. Clearly, this technology can save you from more than embarrassment.





Technology we love: Radar-guided brakes that help you go faster.

Smooth sailing at any speed. That's the aim of Volvo's Driver Support Package which includes Adaptive Cruise Control with Full Auto Brake and Pedestrian Detection. The core of the system, Adaptive Cruise Control (ACC), goes beyond the basic accelerator management of ordinary cruise control by working with the advanced braking system. The interaction between your car's stop-quicker and go-faster functions managed by ACC – and informed by continuous input from its camera and radar scouts on point – helps you maintain a comfortable speed and a safe distance from vehicles ahead. And that's at any speed – whether in heavy traffic queues or at open highway speeds (0–200 km/h). Having this additional functionality can help save you from the most boring parts of any journey or commute. That way, you can just sail through traffic.



The most forward-looking car ever can also peek around corners.

In an effort to further eliminate blind spot question marks, a special panoramic camera is now available to be discretely mounted on the front grille. This front Park Assist Camera (with a revealing 180° field of view) can help you negotiate blind intersections without creeping into traffic. What's more, it makes parking in tight spots easier – as does the rear Park Assist Camera, also available. Of course, the Blind Spot Information System, available with the retractable side mirrors, also features camera technology to help you move forward without surprises. With these technologies and more, Volvo's driver control interface helps you select and adjust parameters simply.



Professional driver. Favourite track. Testing Premium Sound System.

Every component of the all-new Volvo S60 is thoroughly tested to meet the highest standards. From the exterior styling accessories seen here to the grocery bag holder in the boot, no detail is too small to perfect. For example, even the 650-watt Premium Sound Multimedia system – with Class D digital amplification, 12 high-output speakers, a multimedia DVD player, and a 7" colour screen – is tested to the limits to deliver inspiring performance. But remember, just because you can turn the stereo up full blast doesn't mean you should.



Welcome to the drive-in theatre for the 21st Century.

Driving the all-new Volvo S60 provides all the entertainment one could require, but since there can only be one driver at a time, new world-class diversions are available for your passengers, too. Imagine this spectacle: DVD-video and digital TV reception brilliantly displayed on a 7" colour screen and music expressed so cinematically, everyone aboard feels centre stage. The protagonists in this narrative are the new multimedia systems and the deluxe surroundings. Of course, the car must be parked to watch a video or the TV on the front screen, but while driving, song playlists, park assist camera views, navigational maps, personal settings and more can be displayed here using the driver control interface and its scroll wheel selector on the steering wheel.



Reserved seating available.



Sweeping interior lines express the all-new Volvo S60's flowing racetrack design concept. Realised using the finest safe-scent materials – with a fit, finish and environmental respect that set the standard for car interiors – every classy detail here serves a purpose.

Acclaimed year after year for having the most comfortable car seats in the industry, Volvo has expanded the definition of premium comfort to include cleaner cabin air. With the Electronic Climate Control (ECC), the Clean Zone Interior Package (CZIP) and the Interior Air Quality System (IAQS), sitting in a Volvo can be most refreshing.





Audience participation encouraged.

Welcome. This is where comfort and refinement conspire to spoil you and your guests. Where sophisticated technology and premium materials reward each passenger at every turn. Where form follows function – all the way to fabulous. In absolute terms, this is what smart Scandinavian design by Volvo is all about. Now enter the cabin of your all-new Volvo S60, search your navigation system for directions to “the lap of luxury” and don’t be surprised to hear the synthesised lady say, “you have reached your destination”.

Guests sitting in the rear seats (waiting to drive) can be pleasantly distracted by the rear seat entertainment system (RSE). Its front headrest-equipped 7-inch screens with integrated DVD players can operate independently to suit each passenger. Wireless headphones are cool, too. And with the rear 60/40 fold-flat seats, your backseat VIPs will have a centre armrest with cup holders and convenient storage.

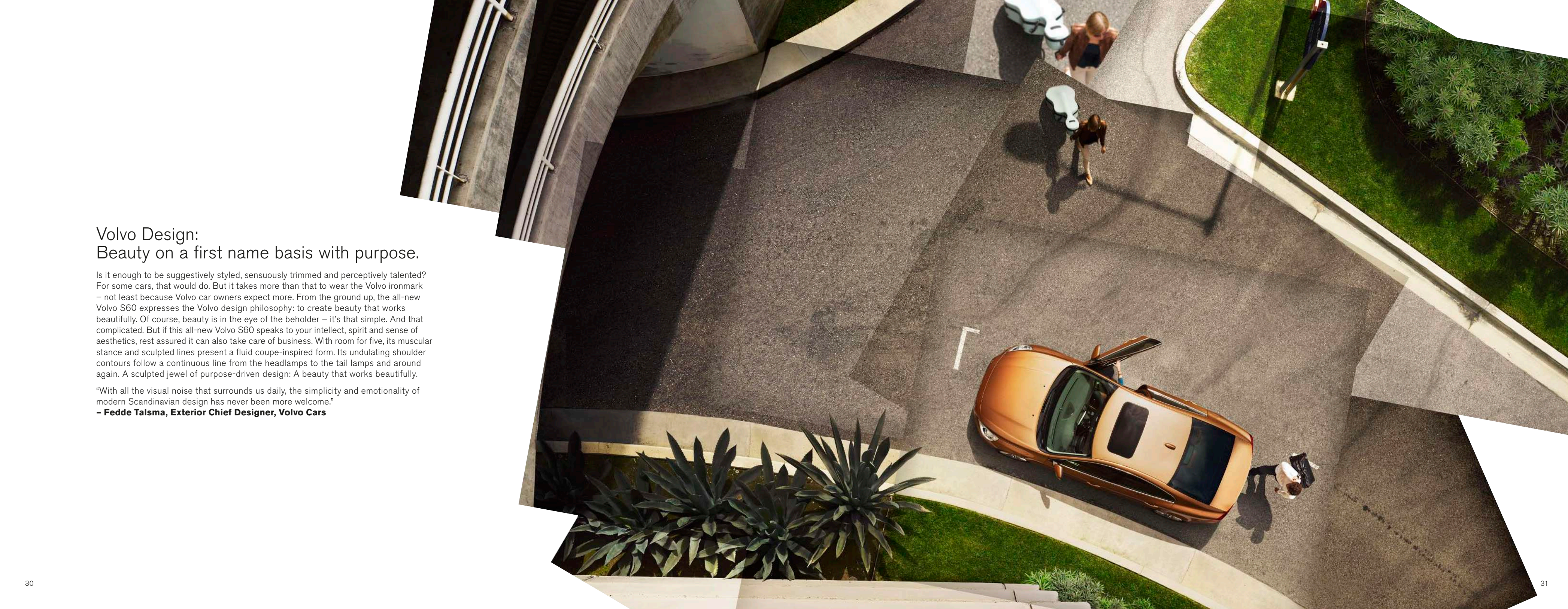

An aerial, high-angle photograph of a Volvo S60 sedan in a courtyard. The car is a metallic orange color and is parked on a dark asphalt surface. The driver's side door is open. A person is standing near the rear of the car, and another person is walking away in the background. The courtyard is surrounded by concrete walkways, green grass, and various plants, including large agave-like plants in the foreground. The lighting is bright, casting distinct shadows.

Volvo Design: Beauty on a first name basis with purpose.

Is it enough to be suggestively styled, sensuously trimmed and perceptively talented? For some cars, that would do. But it takes more than that to wear the Volvo ironmark – not least because Volvo car owners expect more. From the ground up, the all-new Volvo S60 expresses the Volvo design philosophy: to create beauty that works beautifully. Of course, beauty is in the eye of the beholder – it's that simple. And that complicated. But if this all-new Volvo S60 speaks to your intellect, spirit and sense of aesthetics, rest assured it can also take care of business. With room for five, its muscular stance and sculpted lines present a fluid coupe-inspired form. Its undulating shoulder contours follow a continuous line from the headlamps to the tail lamps and around again. A sculpted jewel of purpose-driven design: A beauty that works beautifully.

“With all the visual noise that surrounds us daily, the simplicity and emotionality of modern Scandinavian design has never been more welcome.”

– **Fedde Talsma, Exterior Chief Designer, Volvo Cars**

Beautiful escape.
Safe return.
Repeat as needed.

As fun as the all-new Volvo S60 is to drive, there are times when you'll have to park it. And leave it. One last glance over the shoulder offers some comfort, but having the right technology in hand could provide more security. Specifically, we recommend carrying an intelligent key fob, Volvo's Personal Car Communicator (PCC). With it you can check the status of your car from a distance to see if it's locked, unlocked or if the alarm has been triggered. Up close with the PCC in your pocket or handbag, doors will unlock automatically when you grasp a door handle. Once inside, you can start the car immediately without inserting a key – with personal settings honoured. Other security enhancements available include a level sensor that can alert you if an admirer is attempting to steal your wheels or tow your car.





THERE'S MORE TO LIFE THAN A VOLVO. THAT'S WHY WE DESIGN OUR CARS TO SUPPORT YOU IN ANY SITUATION ON THE ROAD. THAT'S WHY OUR SAFETY TECHNOLOGY HAS PUSHED AUTOMOTIVE DEVELOPMENT FOR MORE THAN EIGHTY YEARS. THAT'S WHY WE AIM FOR A FUTURE WHERE CARS DON'T CRASH. THAT'S WHY WE LEAD THE WAY TO ZERO EMISSIONS, AND OFFER ONE OF THE PREMIUM SEGMENTS STRONGEST RANGES OF LOW CO₂ ALTERNATIVES. AND THERE ARE ALL THE REASONS IN THE WORLD TO MOVE THE BOUNDARIES FOR WHAT'S POSSIBLE AND WHAT'S NOT. THAT'S WHY WE INNOVATE FOR LIFE.

EYES IN THE BACK.

Park Assist and Park Assist Camera let you know what's going on behind your car when reversing.

PERSONAL GATEKEEPING.

Inspired by fighter aircraft technology, the Intelligent Driver Information System (IDIS) can help reduce your workload in stressful situations.

AN EYE ON THE BLIND SPOT.

The Blind Spot Information System (BLIS) helps you detect vehicles entering your blind spot. Included in the Driver Support Package.

KEEPING A SAFE DISTANCE.

Collision Warning with Full Auto Brake warns if you're too close to a vehicle in front – at all speeds – and brakes the car automatically if a collision is imminent. Included in the Driver Support Package.

STAYING ALERT.

Driver Alert Control alerts you if you begin to lose concentration and need a break. Included in the Driver Support Package.

POSITION CONTROL.

Lane Departure Warning warns you if you begin to drift between the lanes. Included in the Driver Support Package.

SEE AROUND CORNERS.

When parking or exiting a narrow lane, Front Blind View Camera helps you discover what's approaching from the right and left sides.

STAY ON TRACK.

Dynamic Stability and Traction Control (DSTC) improves handling, safety and fun in a wide range of challenging situations.

SMOOTH CRUISING AT ANY SPEED.

Adaptive Cruise Control (ACC) automatically maintains your set speed and distance to the vehicle ahead of you – whether you're driving on the highway or in slow moving stop and go traffic. Included in the Driver Support Package.

PEDESTRIAN DETECTION.

Using radar and camera technology, Collision Warning with Full Autobrake can also detect pedestrians in front of your car and brake automatically if needed. Included in the Driver Support Package.

URBAN COLLISION AVOIDANCE.

City Safety – the world's first standard-fitted collision avoidance and mitigation technology – brakes your car automatically if you're about to run into a slower moving or standstill vehicle at speeds up to 30 km/h.

ON-ROAD ENLIGHTENMENT.

Active Bending Lights (ABL) with Dual Xenon technology expands your vision range when driving in the dark and provides considerably improved illumination around bends.

Innovated for your enjoyment, the Volvo safety technologies will protect more than the fun of driving.

Across the world, Volvo equals safety. And that comes with good reason, because few carmakers can match our record of safety innovations and the commitment for safety that has guided us for more than 80 years. Of course, this makes us extremely proud. But we're not satisfied. Because we know what we want to achieve: zero accidents. This huge task calls for innovative thinking and a brand new approach to the way we design cars. Good news is we've already come a long way. For starters, our cars are more fun and engaging to drive than ever (because a bored driver will never be a safe driver). Neither is the technology needed any figment of the imagination – some is already available in your Volvo. This means driving a Volvo today is like having a first peek at a very exciting automotive future – a future where passionate engineering and design do more to help you get the most out of life.

After all, there's more to life than a Volvo.

FUEL-SAVING DESIGN.

To reduce energy-losses from wind and roll resistance, we utilise advanced aerodynamic design, light-weight materials and low friction technology. Together with state-of-the-art engine technology, this lowers your CO₂ emissions and helps you travel further on less fuel.

85% RECYCLABLE.

To help minimise its total environmental impact, every Volvo is designed to facilitate recovery and recycling at the end of its useful life.

SAFER INTERIOR MATERIALS.

All our upholsteries and interior textiles are tested for certain allergy-inducing or harmful substances and comply with Oeko-Tex Standard 100. And several interior metal details are tested with regard to contact allergies. Good for you, and for anyone who shares your ride.

ALLERGY-APPROVED INTERIOR.

Clean Zone Interior Package (CZIP) provides cabin air that is so clean it is recommended by the Swedish Asthma and Allergy Association.

CLEAN COLOURS.

To reduce usage of environmentally hazardous solvents, all Volvo exterior colours are water-based. What's more, our painting facilities are among the cleanest in the world.

FRESH CABIN AIR.

Continuously monitoring incoming air and shutting out carbon monoxide, ground-level ozone and nitrogen dioxide, Volvo's Interior Air Quality System helps ensure that the air you breathe in the car is cleaner than that outside when driving in heavy city traffic.

GREEN AT THE RED LIGHTS.

To further reduce fuel consumption and CO₂ emissions with up to 8% when driving in the city, Volvo's Start/Stop technology will be introduced later in 2010.

MAXIMISED FUEL EFFICIENCY WITH DIESEL.

Volvo's advanced common-rail turbodiesel technology ensures superior fuel economy and low CO₂ emissions – choose between the new five-cylinder single-turbo 160 hp D3 and the twin-turbo 205 hp D5.

BRAKE FOR ENERGY.

Everytime you brake, the battery is fed with extra power. Smart and fuel-saving.

MINIMUM DRAG.

Born in Volvo's state-of-the-art wind tunnel, the S60 cuts flawlessly through air. For example, flat under body panels allow the air to flow more freely and contribute to lower fuel consumption.

CLEANER EXHAUST.

Fast responding after a cold start, Volvo's advanced emission control eliminates between 95 and 99% of carbon monoxide, hydrocarbons and nitrogen oxides from petrol engine exhaust gases. The Volvo turbodiesels feature a particulate filter that removes about 95% of the particles from the diesel exhaust gases. All engines comply with stringent Euro 5 emission requirements.

Designed to catch the light brilliantly, this car also reflects a promise.

Thankfully, the automotive industry is moving away from fantasyland to the real world. Our journey towards a better environment started already in early 70's. Then we were among the first carmakers to acknowledge the environmental downside of cars and to do something about it. Since then we are constantly innovating to reduce the environmental impact of the cars and how we make them.

Today's biggest challenge is, of course, to reduce the carbon dioxide emissions that cause climate change. Today we offer one of the premium segments strongest ranges of low CO₂ alternatives: the Volvo DRIVE variants. Utilising innovative powertrain technology together with advanced aerodynamics, low friction technology and lightweight materials, the DRIVE range is an important step towards zero emissions.

In near future we will introduce new technology such as plug-in hybrid vehicles that will further reduce CO₂ emissions and can be charged from a standard wall socket. And we're heavily engaged in the development of electrical vehicles – a technology that will dramatically reduce the environmental footprint of our cars and make them even more fun to drive.

Good for you, and for the world we share.

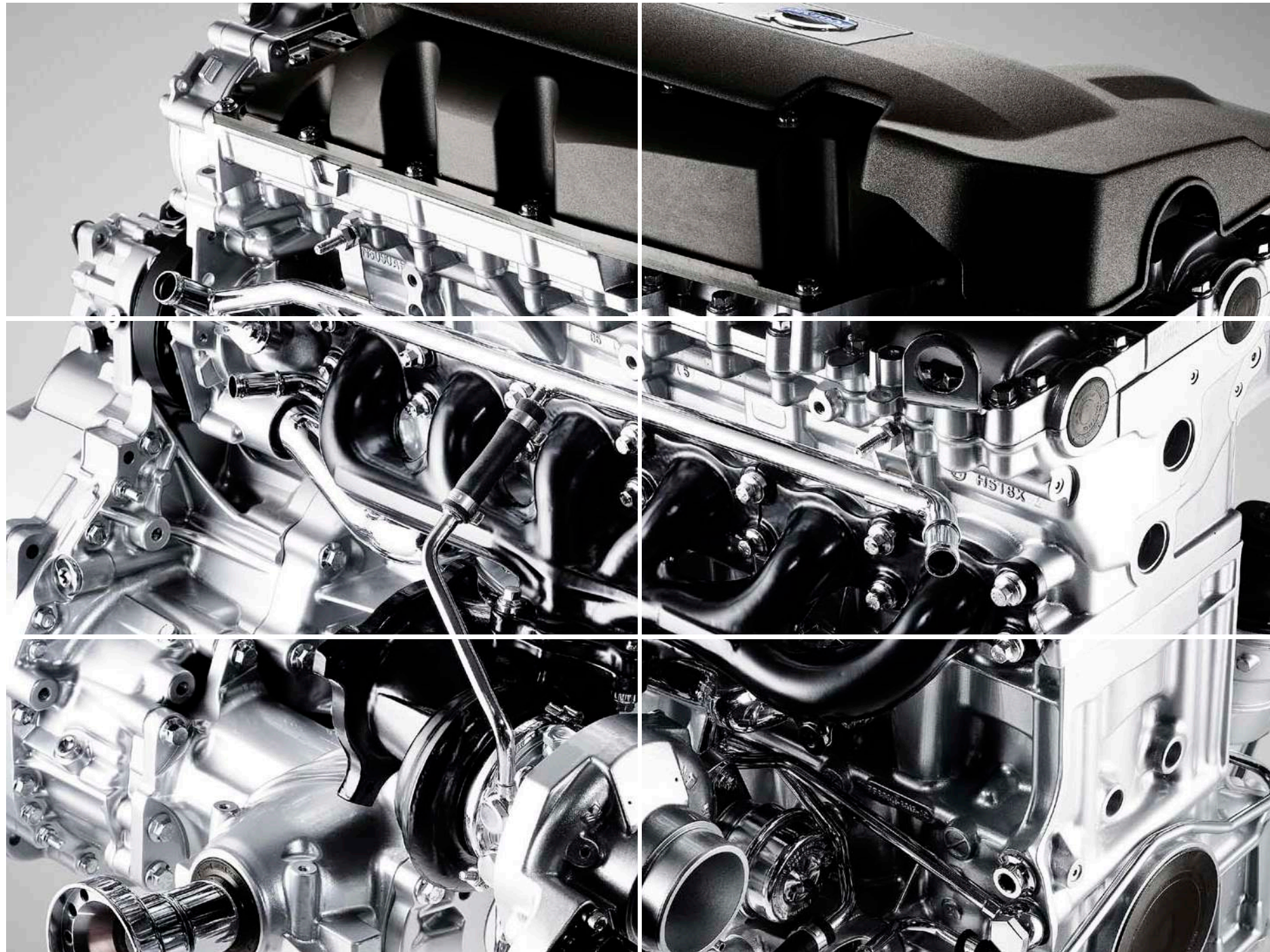

Your all-new Volvo S60 starts here.

The engine you choose will define a major part of the experience ahead. Some engines favour high performance, others favour high mileage, but all of these petrol and diesel engines deliver instant power and smooth running while state-of-the-art technology makes the most of every micro-drop of fuel. Which engine is going to start you up?

T6 AWD

Enjoy the smoothness and dynamics of a supreme in-line six-cylinder petrol engine. The refined 3.0-litre T6 features a twin-scroll turbo for instant exhilaration at all revs – an impressive max torque of 440 Nm is at your disposal already from 2100 revs. This engine is the ultimate in both performance and comfort, while smart technology such as brake energy regeneration adds to high fuel efficiency. For even more sport, this engine is mated to Volvo's all-wheel drive with Instant Traction™ and a six-speed Geartronic automatic with sports mode.

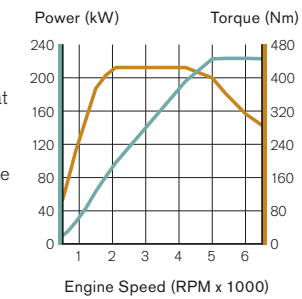

239 CO₂ g/km | **10.2** l/100 km | **304** hp | **440** Nm | **Euro 5**

D5 AWD/D5

High demands on refinement and pure efficiency? Volvo's high-performance 2.4-litre five-cylinder turbo diesel with brake energy regeneration may be just for you. Sequential twin turbo chargers ensure immense power across the rev range – max torque 420 Nm is at your disposal at 1500-3250 revs. There are always ample resources for quick overtaking, especially between 80 and 120 km/h. The smooth engine character contributes to harmonious driving on the highway as well as in the city. And whenever you're in the mood for more sports the D5 is ready to play. Choose between a six-speed manual or a six-speed Geartronic automatic – and for ultimate dynamics you can add all-wheel drive with Instant Traction™.

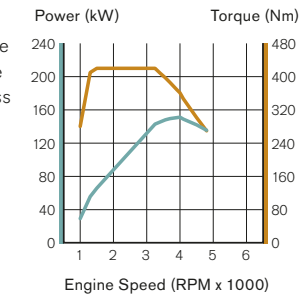

157/194 CO₂ g/km | **5.9/7.3** l/100 km | **205** hp | **420** Nm | **Euro 5**

2.0T

For the petrol head inside you, we loaded the new generation 2.0T with the very latest petrol engine technology. High precision direct fuel injection together with a turbocharger gives this 2.0-litre four-cylinder power plant the powerful characteristics of a larger engine – without its high fuel consumption. You can enjoy instant acceleration and a relaxed driving experience in all driving situations. Other fuel saving technology, like brake energy regeneration, helps keep carbon dioxide emissions low. For this engine, you can choose between a distinct six-speed manual gearbox and a lightning dual-clutch six-speed Powershift automatic.

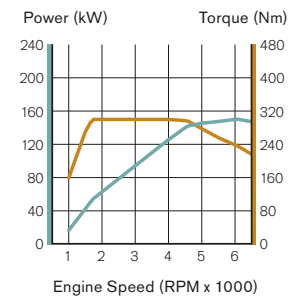

184 CO₂ g/km | **7.9** l/100 km | **203** hp | **300** Nm | **Euro 5**

D3

We designed the all-new 2.0-litre five-cylinder turbo diesel of a very special reason: to give you a top-notch driving experience in terms of refinement and fuel efficiency. The single turbo charger ensures immense power just above idling. The relaxed character and flexibility of this engine will infuse your drive with the composed feeling of being in control in all situations without compromising on the fun of driving. And sipping a barely 5.2 litres fuel per 100 km, superior mileage and low CO₂ emissions are there for you to enjoy. The D3 features brake energy regeneration and comes with a six-speed manual gearbox or a six-speed Geartronic automatic.

Technical data not available at the time of printing.

137 CO₂ g/km | **5.2** l/100 km | **160** hp | **400** Nm | **Euro 5**

N.B. The engine programme may vary from country to country. Please ask your Volvo dealer for further information.



Thousands of combinations. Zero Weirdness.

Add luxury and comfort beyond the impressive standard equipment level by choosing one of these equipment levels – Kinetic, Momentum or Summum. After you choose one, imagine how you can further personalise your all-new Volvo S60 with options and accessories featured on the pages that follow. For more information, please contact your local Volvo dealer. If you don't see everything you want here, you can see more online. Visit www.volvocars.com

Base

Includes:

40/60 split rear seat | 5" colour screen | 7.0 x 16" steel wheels | Airbag, driver & passenger side | AUX input | B-pillar outlets | Belt reminder all positions | Car setting memory in key remotes | Charcoal decor inlays | City Safety | Dual chamber side airbags | Dual cup holders, front | Dynamic Stability and Traction Control (DSTC) with Advanced Stability Control, Traction Torque Vectoring and Sport Mode | Electrically operated parking brake | Front and rear seat 12V outlet | Headlamp level adjuster | Heated washer fluid nozzles | Illuminated vanity mirror, passenger side | Inflatable Curtains (IC) | ISOFIX, rear | Mellbystrand textile upholstery | Performance audio system | Remote control central locking | Single zone Electronic Temperature Control (ETC) | Temperature gauge, outer | Trip computer | Tyre sealant kit | Whiplash protection, front (WHIPS)



+ Kinetic

Includes Base equipment level plus the following:

12V power outlet cargo area | 7x16" Oden Aluminium wheels | Audio controls in steering wheel | Cruise control | Cut-off switch passenger airbag (PACOS) | Dual zone Electronic Climate Control (ECC) | Illuminated vanity mirror, driver side | Leather-clad gear knob | Leather-clad steering wheel | Rear armrest with cup holders and storage | Textile floor mats

+ Momentum

Includes Kinetic equipment level plus the following:

7x17" Balder Aluminium wheels | Air quality system (IAQS) | Automatically dimmed inner mirror | Bright work decor around side windows | Grocery bag holder cargo area | High Performance audio system | Leather-clad steering wheel with Silk Metal inlay | Park assist rear | Rainsensor | Retractable rear view mirrors with ground lights | Shimmer Graphite Aluminium decor inlays | Tylösand textile/T-Tec upholstery | Uni decor climate control mannekin | Watch dial instruments



+ Summum

Includes Momentum equipment level plus the following:

Active Bending Light Dual Xenon (ABL) | Bright work decor front foglight area | Headlight high pressure cleaning | Leather upholstery | Power driver seat with memory incl. side mirrors

Exterior styling accessories

Includes:

Freja 18" aluminium wheels (available in two colours, Diamond Cut/Dark Grey Matt and Diamond Cut/Light Grey) | Front skidplate | Front deco frames | Rear skidplate | Side scuff plates | Visible endpipes (available for all engine variants, both single and double endpipes)

The exterior styling accessories can be fitted to all engine and equipment level variants.

N.B. The contents in the equipment levels may vary from country to country. Please ask your Volvo dealer for further information.



Want a dynamic touch?

Be one with your S60. Your body is held firmly yet comfortably in place by the Offblack leather sport seats. The leather-clad steering wheel with Silk Metal inlay and leather-clad gear-knob are planted in your hands. The watch-dial gauges give you instant and vital information. Shimmer Graphite Aluminium centre stack adds to a distinctive air of sports. So if stylish and sporty looks set your pulse racing, this may be the Volvo S60 for you. Here shown in Black Stone with Sleipner 18" aluminium wheels, accessory rear spoiler and endpipes.



Or modern luxury?

Soothe your senses surrounded by sophisticated timeless elegance. Meticulously crafted sport seats upholstered in Softbeige leather add to an uplifting yet relaxed experience. The leather-clad steering wheel and gear knob are soft to the touch. State-of-the-art supportive technology is within easy reach in the centre stack, featuring authentic Urbane Wood for an unmistakable Scandinavian flair. Elegant from inside and out, this Volvo S60 is painted in Flamenco Red metallic and features Njord 17" aluminium wheels.



Colour your Volvo.

When it comes to the appearance of your Volvo, the choice of exterior colour, wheels and other styling items are probably your most important design decisions. For more exterior styling options and to build your new Volvo online, please visit www.volvocars.com

Inscription

Inscription is our exclusive design programme for a truly distinguished look.



614 Ice White



481 Cosmic White metallic



426 Silver metallic



477 Electric Silver metallic



490 Chameleon Blue metallic



498 Caspian Blue metallic



612 Passion Red



702 Flamenco Red metallic



484 Seashell metallic



703 Electrum Gold metallic



704 Vibrant Copper metallic



492 Savile Grey metallic



487 Ember Black metallic



452 Black Sapphire metallic



019 Black Stone



Freja, 8x18", Diamond Cut/Dark Grey Matt



Freja, 8x18", Diamond Cut/Light Grey



Sleipner, 8x18", Silver Bright



Njord, 8x17", Silver Bright



Balder, 7x17", Silver Stone



Oden, 7x16", Silver Stone

The first rule of personalisation is: there are no rules.

Beyond the functional, sensual and practical appointments for your all-new Volvo S60, there is also the exterior styling to consider. What personal touches will you add to express your style? You can be as subtle as lockable wheel bolts, as sporty as a rear spoiler, or as matter-of-fact as mud flaps. It's your car.

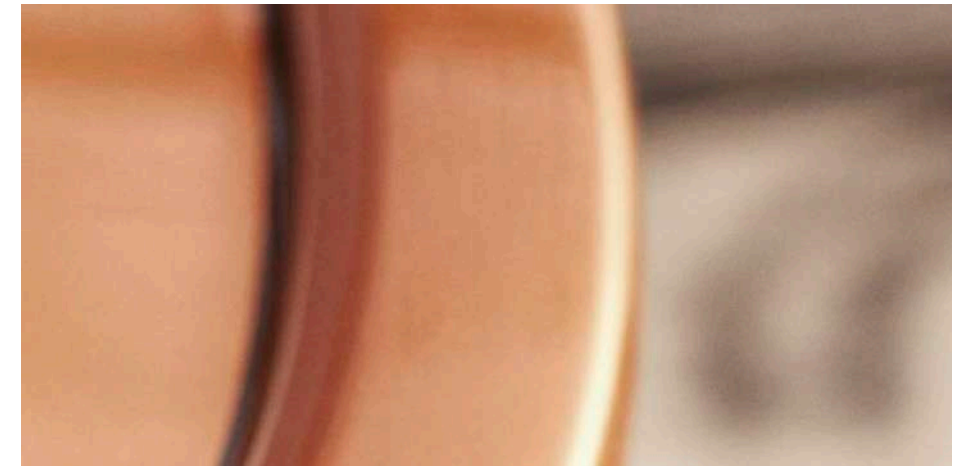



It doesn't have to match the drapes.

It's up to you. Add the exterior styling accessories and any preconceptions about what defines pure passion are upgraded here. More assertive than conventional street wear, these exterior styling accents reflect a spirit of independence and a belief in personal freedom. Oh my. What will the neighbours say?

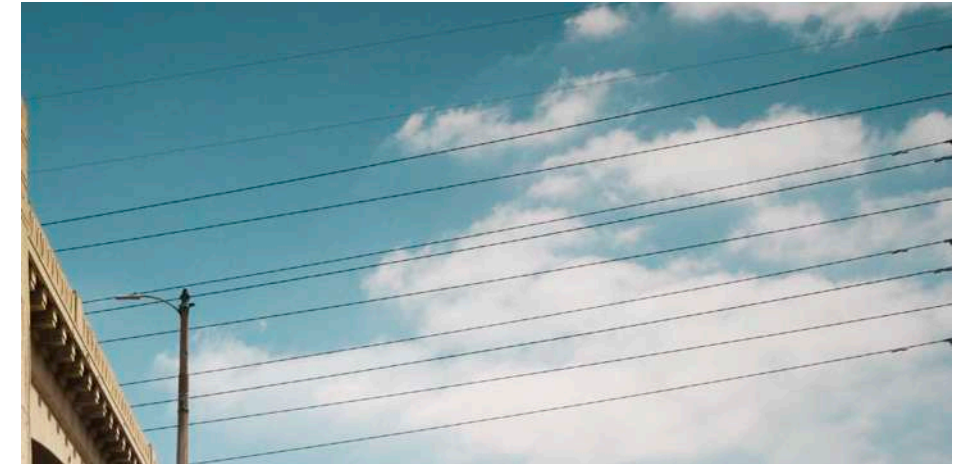

The exterior styling accessories includes a front skid plate, a rear skid plate with visible exhaust pipes (single or double pipes depending on your engine specification), side scuff plates, dual front deco frames (all in matt aluminium finish), Diamond Cut 18" Freja wheels (in Dark Grey matt or the Light Grey shown here) and a colour-coordinated rear spoiler. These assertive details accentuate the road-hungry stance of the all-new Volvo S60.



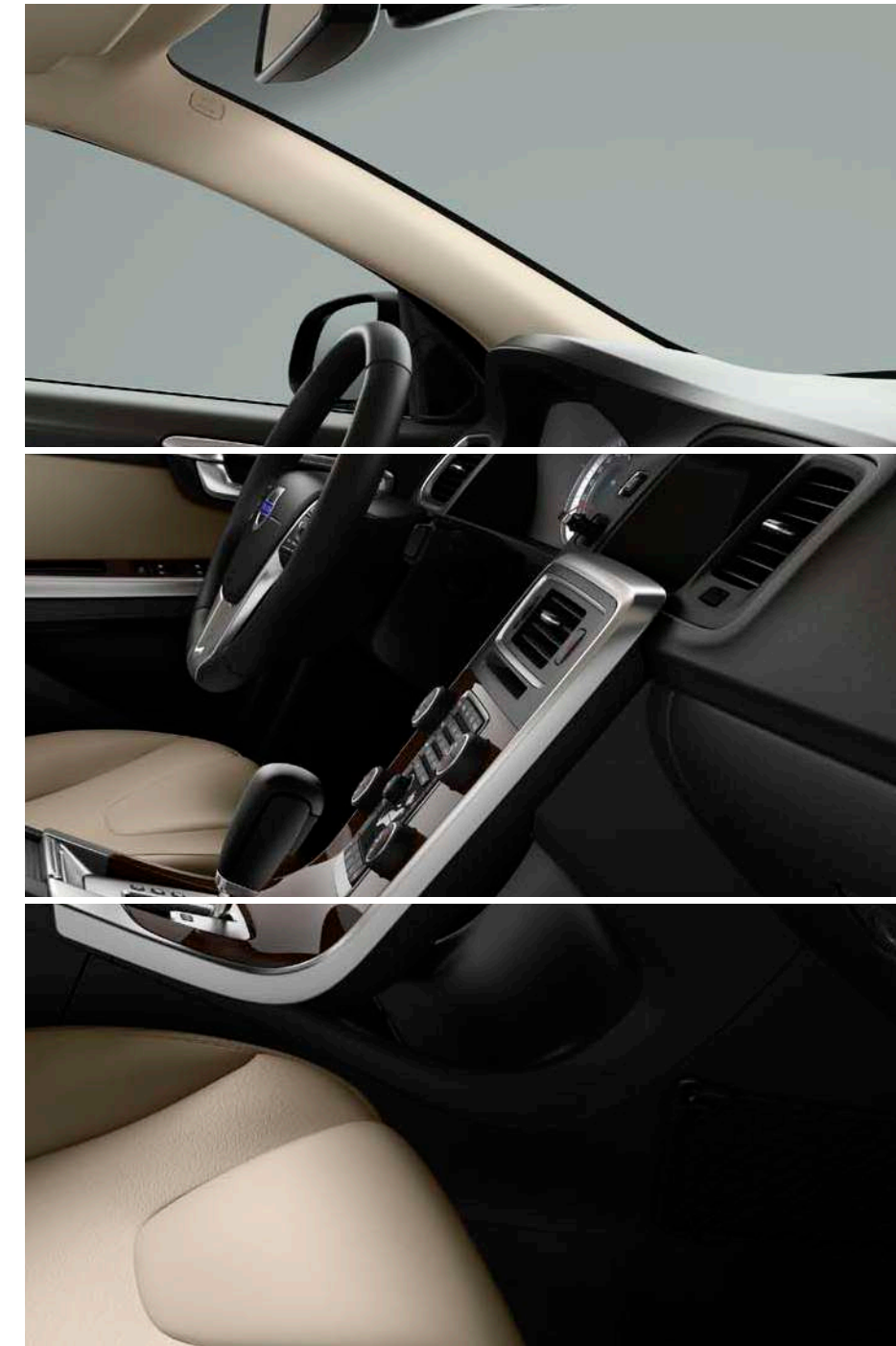

A little real wood and real leather action couldn't hurt.

The all-new Volvo S60 is a bold expression of modern Scandinavian design and pure driving pleasure. How will you make the most of yours? The interior design is where things get really personal. What will you select to define your style and the character of your all-new Volvo S60? Volvo's genuine leather interiors are exquisite to the touch and crafted with meticulous care as are the real wood inlays.



Mellbystrand, Textile, Charcoal in Anthracite Black interior, 3001, Charcoal decor inlays



Tylösand, T-Tec/textile, Charcoal in Anthracite Black interior, 3601, Shimmer Graphite Aluminium decor inlays



Tylösand, T-Tec/textile, Softbeige in Anthracite Black interior, 3602, Urbane Wood decor inlays



Tylösand, T-Tec/textile, Softbeige in Sandstone Beige interior, 3612*/361B** Charcoal decor inlays



Leather, Offblack in Anthracite Black interior, 3101, Shimmer Graphite Aluminium decor inlays



Leather, Offblack/Beechwood in Anthracite Black interior, 3103, Charcoal decor inlays



Leather, Softbeige/Offblack in Anthracite Black interior, 3102, Urbane Wood decor inlays



Leather, Softbeige in Sandstone Beige interior, 3112*/311B**, Urbane Wood decor inlays



Leather, Softbeige/Beechwood in Sandstone Beige interior, 3113*/311C**, Shimmer Graphite Aluminium decor inlays



Leather-clad steering wheel, Charcoal



Leather-clad steering wheel, Charcoal with Silk Metal inlay



Leather-clad steering wheel, Charcoal/Soft Beige with Silk Metal inlay



Merchandise Watch



Charcoal



Shimmer Graphite

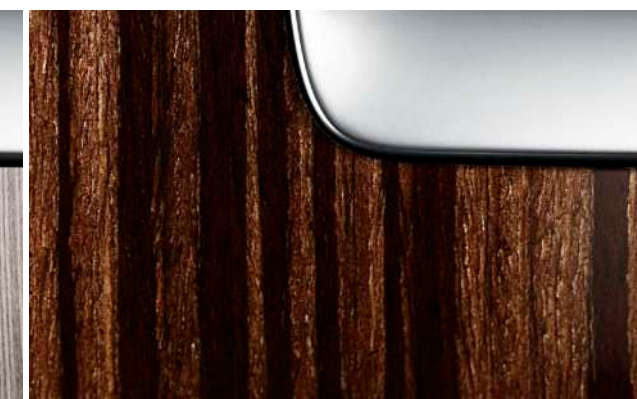

Urbane Wood

* With Offblack instrument panel top
** With Espresso instrument panel top



Leather-clad gearknob, Charcoal, manual



Leather-clad gearknob, Charcoal, Geartronic and Powershift

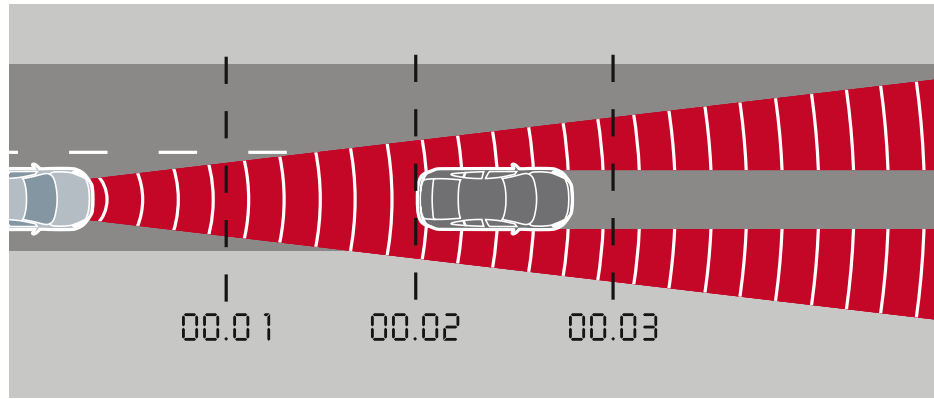

Adaptive Cruise Control (ACC) with Queue Assist and Distance Alert

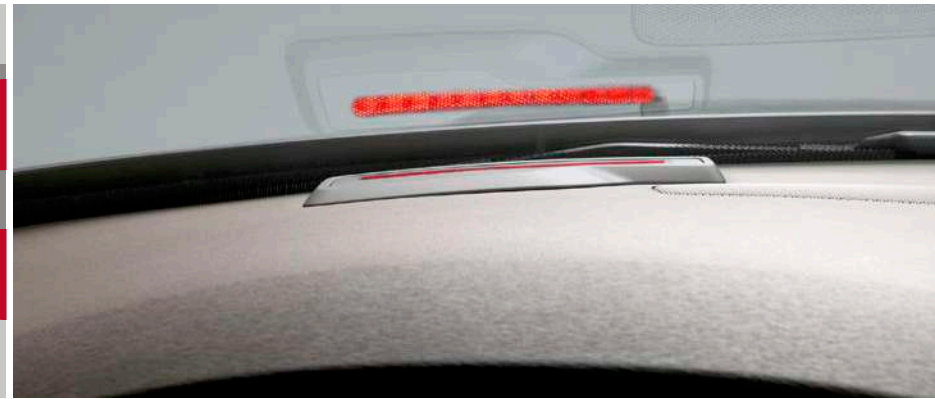

Collision Warning with Full Auto Brake and Pedestrian Detection

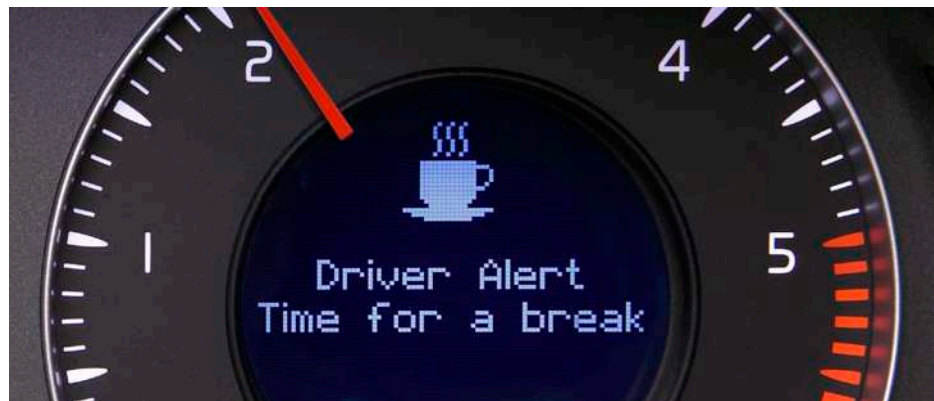

Driver Alert Control (DAC)

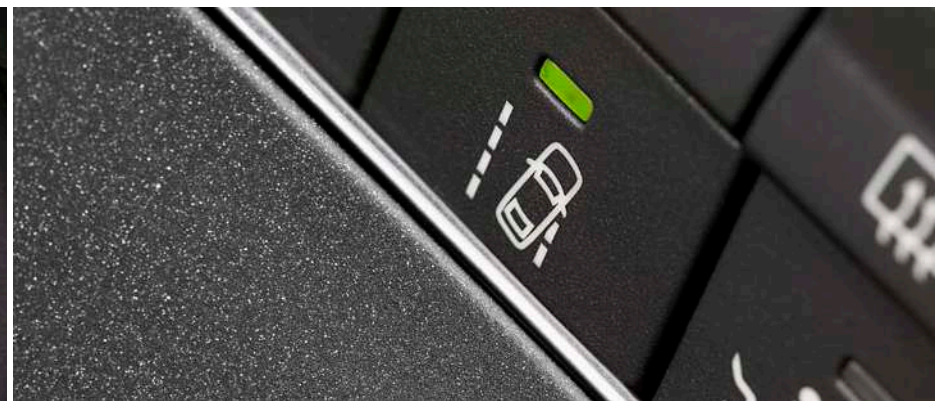

Lane Departure Warning (LDW)



Blind Spot Information System (BLIS)

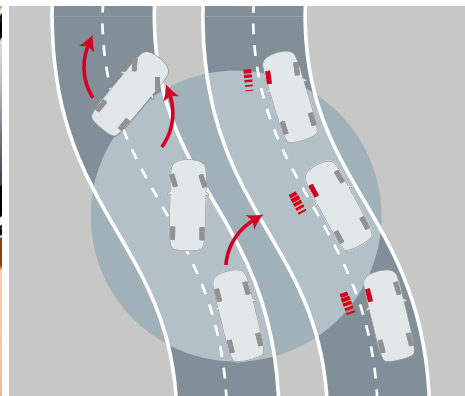

Dynamic Stability and Traction Control (DSTC)



Active Bending Lights (ABL)

Safety

SAFETY Preventive

Driver Support Package

Adding to both your safety margins and the driving experience, Volvo's most advanced safety innovations are available in this comprehensive package. Among many things, this includes groundbreaking supportive technology to help avoid collisions, detect pedestrians and alert a distracted driver.

Driver Support Package contains the following features: Adaptive Cruise Control (ACC) with Queue Assist and Distance Alert, Collision Warning with Full Autobrake and Pedestrian Detection, Driver Alert Control (DAC), Lane Departure Warning (LDW) och Blind Spot Information System (BLIS).

Adaptive Cruise Control (ACC) with Queue Assist and Distance Alert

Helping the driver to keep a safe distance from vehicles in front at all speeds up to 200 km/h, this third generation ACC is a supportive partner for a more relaxed driving experience on any journey. In slow moving city traffic up to 30 km/h, the new Queue Assist function automatically adapts your speed to the vehicle in front. From standstill, a press of a button or the accelerator is all it takes to make your car smoothly tail the vehicle in front. At speeds over 30 km/h, just select the desired speed and the minimum time gap to the vehicle in front. When the radar sensor detects a slower vehicle in front, the speed automatically adapts to that vehicle. And when the road is clear, the car resumes the selected speed. If ACC is disengaged and a vehicle in front comes too close, Distance Alert activates a red warning light in the lower section of the windscreen to help you keep a proper distance.

Collision Warning with Full Auto Brake and Pedestrian Detection

Statistics show that in 50% of the rear end collisions the causing driver doesn't brake at all. Active in all

speeds above 4 km/h, this third generation collision avoidance technology can warn you if you're too close to a vehicle in front or if there are pedestrians in your path. If you don't react and a collision is imminent, full auto-braking is engaged to help you avoid or mitigate an impact. Within a range of 150 metres, a radar sensor behind the grille and a digital camera behind the windscreen continuously monitor the distance to the vehicle driving in front of you. During daylight it can also detect standing or moving pedestrians. If a pedestrian unexpectedly steps out in front of your car or if a vehicle suddenly brakes (or is stationary) and Collision Warning senses that a collision is likely to happen, it will alert you to act with a flashing red warning light on the windscreen along with an audible alarm. Moreover, this technology supports driver-initiated braking by pre-charging the brakes to quickly prepare for panic braking and help shorten the reaction time. If you don't react to the warning and a collision is imminent, the car immediately brakes with full braking force.

Driver Alert Control (DAC)

Up to 90% of all traffic accidents are caused by driver distraction. Driver Alert Control is a unique technology that can help alert a tired or distracted driver at speeds over 65 km/h. Using signals from a digital camera to monitor the road ahead along with data from steering wheel movements, DAC can compare erratic behaviour to your normal driving style. A level indicator helps you keep an eye on your alertness status. If DAC detects that your driving behaviour shows signs of drowsiness or distraction, you receive an audible warning. At the same time, a message is displayed in the instrument panel suggesting it might be time for a break.

Lane Departure Warning (LDW)

At speeds over 65 km/h, Lane Departure Warning can help prevent single-vehicle road departures as well as collisions caused by temporary distraction.

This function uses the digital camera to register the lane markings and help monitor the car's position on the road. If you weave out of your lane, LDW will alert with an audible signal. If you intentionally cross a lane marker using the direction indicators, LDW is not activated.

Blind Spot Information System (BLIS)

BLIS uses rear-facing cameras installed in the door mirrors to keep a lookout on either side of the car. As a vehicle enters your blind spot, this function can alert you with a lamp built in to the front door post – left or right. Together with the door mirrors, this helps you assess the feasibility of a lane change. BLIS is activated once the car exceeds 10 km/h, and reacts to almost any type of vehicle from a motorcycle upwards, day or night.

City Safety

City Safety collision avoidance technology is a Volvo world-first standard feature for safer urban driving. At speeds up to 30 km/h, this laser-based technology can sense if a vehicle in front within 6–8 metres is at a standstill or is moving slower. If City Safety senses an impending collision, the brakes are pre-charged to act faster on your response. And if you don't brake, City Safety automatically applies the brakes and switches off the throttle to help mitigate the effects of a collision. And if the speed difference between your car and the vehicle in front is 15 km/h or less, City Safety can even help you avoid a collision. City Safety is activated when you start the car.

Dynamic Stability and Traction Control (DSTC) with Advanced Stability Control, Traction Torque Vectoring and Sport Mode

By helping prevent fishtails, spinouts and rollovers, stability control technology like DSTC has been described as one of the most vital safety advances of the past decade. And with the advanced features in this Volvo, it will probably also be perceived as

one of the most important fun-to-drive innovations. At the core of DSTC, sensors register the car's direction and roll rate. The system compares this with steering wheel movements as well as the actual rotation of the car's wheels. DSTC is able to detect a potential skid and help counteract one by reducing the engine's power output, or braking on one or more wheels. It also prevents locking wheels caused by engine brake.

The new Advanced Stability Control function features a roll rate gyroscope and acceleration sensor to detect slowly built up skids at an early stage and compensate this with greater precision. As driver, you'll experience this as added stability in dynamic driving where the car is exposed to high lateral forces. Traction Torque Vectoring balances the torque between the front wheels during acceleration while cornering. This reduces understeer when cornering at higher speeds and makes the car even more dynamic – like when you turn onto a main road to catch up with the traffic flow. And when you're in the mood for a more sporty drive, select the Sport Mode. It shuts off the spin regulation and allows more rear skidding and more fun.

Active Bending Lights (ABL)

Compared to conventional halogen headlamps, Active Bending Lights use Dual Xenon technology to expand your vision range by about 230%. This means you'll be helped to gain 45 metres more for braking. And using motorised lamps that turn up to 15° in either direction, this technology gives a 90% boost to your vision round bends at night. You can enjoy highly effective low beam illumination on narrow, winding roads and extremely powerful full beams on the motorway. A daylight sensor disengages the adaptive function during daytime to extend its lifespan. Independent of the load, these headlights self-adjust to maintain the correct angle to the road – even during hard acceleration or braking.



Volvo's interactive safety technologies



Whiplash Protection System (WHIPS)



Passenger airbag cut-off switch

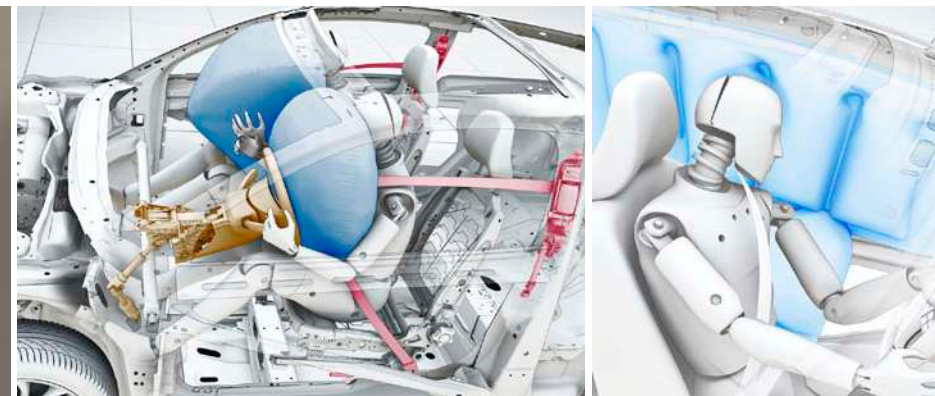

Restraint technologies

Intelligent Driver Information System (IDIS)

To help avoid distractions during critical driving situations, IDIS constantly analyses your driving and will delay secondary information from the car or one of its onboard systems – such as the GSM phone – when it detects intense steering, braking or acceleration. As soon as things calm down, the phone call or the delayed information is presented. IDIS can be set up to let GSM calls through in all driving situations.

Anti-locking brakes with Hydraulic Brake Assist (HBA) and Ready Alert Brakes (RAB)

Generously dimensioned anti-locking disc brakes and optimised hydraulics help ensure a short stopping distance in all situations. Furthermore, they withstand tough use without fading. Hydraulic Brake Assist helps you use your brakes to the full in an emergency situation, while Ready Alert Brakes anticipate severe braking and prepare for it by moving the brake pads closer to the discs. Fading Brake Support automatically compensates for the higher pedal forces required after long periods of heavy braking. Electronic Brake Distribution distributes the braking effect between the front and rear wheels to achieve optimal results according to load and driving conditions.

SAFETY Protective

In a Volvo, safety is about interaction. Because it's not the number of safety features that determines how safe a car is. It's how well they seamlessly interact to help keep the occupants out of harm's way.

IN A FRONTAL COLLISION the patented frontal structure will yield to help absorb and disperse crash energy. The compact powertrain is designed to help optimise deformation. Inside the car, safety belts

interact with the collapsible steering column and dual-stage airbags to help keep the occupants out of harm's way. Pre-prepared restraints – a unique Volvo technology – help optimise the various restraint systems for expected crash force.

IN A ROLL-OVER the robust safety cage and the reinforced roof structure together with the safety belts and belt pre-tensioners will help protect the occupants. If the car first has been hit from the side, the Inflatable Curtain (IC) deploys to help provide head protection.

IN A SIDE IMPACT Volvo's unique Side Impact Protection System (SIPS) helps distribute the crash forces across the car's body, away from the occupants. The side airbags in the front seats help protect the chest and hip, while the Inflatable Curtain (IC) adds head protection.

IN A REAR IMPACT the rear deformation zones will help absorb crash energy. The fuel tank is designed to remain well protected in front of the rear axle. The head restraints help protect the neck and spine, and Volvo's unique Whiplash Protection System (WHIPS) cradles the front seat occupants in a controlled manner to help prevent whiplash injuries.

Restraint technologies

In a collision, Volvo's restraint technologies interact to help reduce the impact. The safety belts with pre-tensioners activate within a few thousandths of a second in the event of a collision and tighten the belt to help keep the occupants securely restrained. The front seat safety belts then release a little so that the driver and passenger are cushioned by the airbags in a controlled manner. Helping to optimise protection, the dual-stage airbags adapt the level of inflation depending on the force of the collision. The

driver's airbag also interacts with the deformation of the collapsible steering column.

Side airbags in the front seats help reduce the risk of serious injuries in a side collision. The Inflatable Curtain (IC) helps protect the heads of both front and rear outboard occupants. It also stays inflated for some seconds to provide prolonged protection for subsequent impacts.

Whiplash Protection System (WHIPS)

Integrated in the front seats, Volvo's WHIPS cradles the occupant to help reduce the risk of whiplash injury and often the result of a low-speed rear impact collision). The function is activated by a collision of sufficient force from behind. Independent research has shown that WHIPS is one of the most effective systems in the world and can reduce the risk of long-term injuries by 50%.

Passenger airbag cut-off switch

This switch allows you to disengage the passenger airbag using the car key. When the airbag is switched off, you are notified via a message in the roof console display. The force of the passenger airbag is designed to help protect adults – children risk serious injury. Therefore, the airbag must first be disengaged if you intend to put a person shorter than 140 cm in the front passenger seat.

Pre-prepared restraints

The restraint technologies of your Volvo are designed to help provide maximum protection while minimising strain on the occupants. Using new technology including a windscreen laser-sensor, this standard safety feature continuously monitors objects in front of the car at all speeds. This makes it possible to prepare and adapt the safety belts and airbags

for expected crash force and thus help optimise protection in a low or mid-severe frontal collision.

Side Impact Protection System (SIPS)

SIPS is a Volvo unique safety system that has been developed to help protect where occupants are most exposed to the crash forces. The steel framework of the car – including the front seats – is designed and reinforced to help displace the impact of a side-collision away from the occupants to other parts of the car body and help prevent intrusion into the cabin. The extremely strong side structure contains ultra-high strength steel to help withstand a severe side impact – even with a larger vehicle. The Inflatable Curtain (IC) for all the outboard occupants and the front seat side airbags interact to help provide further protection.

Energy-absorbing frontal structure

In developing this Volvo's protective qualities, we have focused on frontal collisions at both higher speeds and with heavier vehicles. The patented frontal structure with its sizeable deformation zones in different kinds of steel will yield to help absorb crash energy. The compact powertrain is designed to help optimise deformation. The unique geometry of the frontal structure and longitudinal steel struts in the doors help disperse crash energy away from the front to the rear of the car, further helping to reduce the strain on the occupants. A steel cross-member under the dashboard further helps keep the cabin intact.

Pedestrian protection

To help reduce the risk of serious injuries on unprotected road-users, the front of the vehicle is gently rounded, the headlamps are integrated flush with the body, and the bonnet is energy-absorbing to act as a crumple zone.



► Infant seat (up to 13 kg)



► Convertible child seat (9–25 kg)



► Booster seat (15–36 kg)



► Personal Car Communicator (PCC)



► Power retractable door mirrors with ground lighting



► HomeLink®

SAFETY Child safety

Volvo's child safety programme

To further enhance protection for children, we offer a child safety programme that is among the most comprehensive in the car world. Because infants have large heads and weak necks*, we know that a child up to the age of 3-4 travels most safely facing the rear. Volvo's rear-facing child seats help provide maximum protection in a wide range of collisions. Children who have outgrown the child seat travel most safely seated on a booster seat, secured with the car's safety belt.

* In a frontal collision at 50 km/h, the head of a six-month infant can be exposed to forces corresponding to a load of 100 kg!

Please note: If the front passenger seat airbag is switched on, children under 140 cm in height should never be seated in the front seat – not in conjunction with a child seat, a booster cushion or under any other circumstances.

Power child safety lock

The power child lock enables you to conveniently lock the rear doors and rear power windows from the driver's seat and prevent them from being opened from the inside.

► Infant seat (up to 13 kg)

Infants, from newborns up to about 1 year of age, travel safely backwards in this comfortable seat. It's installed using the car's safety belt. And for extra convenient installation using the car's ISOFIX attachments, an ISOFIX base can be added. Side

wings help protect in a side impact, and the headrest and five-point harness are easily adjusted. The headrest is padded for a comfortable sleep and there's a canopy to block the sun. What's more, the infant seat is easy to carry and can be used as a babysitter.

► Convertible child seat (9–25 kg)

From the age of 9 months to about 6 years of age a child can continue to be seated backwards in this new child seat. Advanced design helps provide world-class protection and flexible seating for many years. The seat is fitted using the car's safety belt and is easily adjusted to help optimise comfort and safety. An integrated support leg helps facilitate safe backward installation. We recommend that children be seated backwards as long as possible. But when a child grows bigger (15–25 kg) and can not comfortably be seated facing to the rear, this seat can also be used as a forward-facing booster cushion that puts a child at the correct position for the car's safety belt.

► Booster seat (15–36 kg)

Volvo's booster seat helps position a child at the correct height for the safety belt and is designed to optimise side impact protection. The headrest and width adjust easily to enhance comfort, and the backrest can be reclined when the child wants to rest.

SAFETY Security

Personal Car Communicator (PCC)

PCC is an advanced remote control that combines keyless drive with two-way communication with your Volvo. Keep the PCC with you and the car unlocks automatically as you pull the door handle. Start the engine by pressing a button on the dash, lock the car by pressing a button in the door handle. Later in the day, if you're wondering whether you've locked the car, PCC can tell; no matter where you are. On your return to the car – within a radius of 60 to 100 metres – pressing the PCC information button will give you a current report on its lock and alarm status.

Laminated side door windows

Laminated side windows turn an attempted smash-and-grab into a time consuming ordeal. They also enhance sound comfort in the cabin and contribute to UV protection. Additionally, this option also includes water-repellent glass in the front side windows for improved visibility in wet weather.

Private locking

Private Locking is a function that allows you to keep the luggage and glove compartment locked even when you lend your key or Personal Car Communicator. To activate Private Locking, a miniature key incorporated within the remote control is used to lock the glove compartment and boot lid. This stops both compartments from being unlocked with the central locking remote control, but allows the central locking system and ignition to be used as normal.

Approach and Home Safe Lighting

Activated with the remote control or Personal Car Communicator, Approach Lighting provides a warm reception on a dark night. This consists of interior and side lights – ground lighting too, if you choose it. Home Safe Lighting is activated with the headlight stalk as you leave the car and it provides a similar courtesy when exiting your car. This feature includes a dipped beam from the headlight to accompany you to your door.

Power retractable door mirrors with ground lighting

At the touch of a button, these door mirrors can be folded flat against the car where they are less likely to get damaged after you've parked. They also fold or unfold automatically every time you lock or unlock the car. The integrated ground lighting is activated with the remote control or with the PCC. Beyond enhancing security to and from your car at night, this is also convenient when getting in and out.

► HomeLink®

With buttons integrated in the sun visor, HomeLink® allows you to operate remote controlled home appliances – such as garage door, home alarm and exterior lighting – without leaving the car.

HomeLink is a registered trademark of Johnson Controls Technology Company.



Power front seats



Electronic Climate Control (ECC)



Power glass sunroof



► **Sun shades**



Front centre armrest, multifunctional

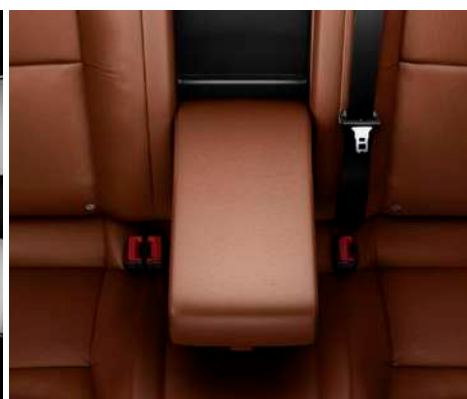

Rear centre armrest



Sunglass holder

Remote-controlled central locking

A touch of a button on the remote locks or unlocks the doors and boot lid. Use the personal settings menu to decide if the remote unlocks the driver's door first or all doors together. You can also close or open all windows (including the sunroof if you have one) and unlock the boot separately.

Automatic door locking

To further enhance your personal security, the doors can be set in the information menu to automatically lock the moment you drive away. Alternatively, lock them swiftly from the front seats using the lock button. Lock buttons are also available for the rear seat passengers.

Remote-controlled alarm

The alarm is connected to the doors, bonnet, boot and ignition. It also reacts to movement inside the car or the breaking of a window. A level sensor can be added to deter thieves from jacking up the car and stealing your wheels. And in an emergency situation, the panic button on the remote control or on the PCC allows you to raise the alarm for help.

Volvo On Call

Activating automatically if any of your car's airbags are deployed – or at the touch of a button – Volvo On Call is Volvo's roadside assistance and emergency service. Not only does it put you in direct contact with a Volvo On Call operator, a built-in GPS system allows them to pinpoint your location and get help to you as soon as possible. The system can also alert you to an attempted break-in, and if the car is stolen it can be traced via satellite. And adding a remote start fuel heater, a warm and comfortable interior is only an SMS away.

Self Supporting Tyres (SST)

In the event of a puncture, Self Supporting Tyres

allow you to keep moving for at least 80 km at max speed 80 km/h. At speeds from 30 km/h and upwards, the Tyre Pressure Monitoring System will alert you if the pressure in one or more of the tyres is too low. Since this type of tyre has a thicker wall to provide necessary support, ride comfort may differ compared to that of conventional tyres. SST requires Njord 17-inch aluminium wheels.

Comfort

COMFORT Seats

Power front seats

Find your perfect driving position with push-button ease. The driver's seat also incorporates a memory function that stores three separate seat and door mirror settings connected to a specific remote control – a feature that's appreciated when the car has several drivers. To facilitate parking, the door mirror on the passenger side tilts automatically when reversing.

Heated seats, front and rear

Adjustable in three settings, heated seats for the driver and front seat passenger add to comfort on those cold mornings. And to enhance comfort for friends in the rear seat, this convenience is also available for the outer rear seat positions.

COMFORT Climate

Electronic Climate Control (ECC)

Electronic Climate Control (ECC) maintains the cabin temperature you choose and can be set

independently for the driver and front passenger. Further contributing to your health and comfort, Volvo's unique humidity sensor helps ensure cabin air has an appropriate level of humidity according to the outside climate.

Interior Air Quality System (IAQS)

Volvo's IAQS continuously monitors incoming air and will, if necessary, temporarily close external air vents to shut out carbon monoxide, ground-level ozone and nitrogen dioxide. Meanwhile, an active carbon filter protects the occupants from other harmful gases and unpleasant odours. This helps ensure that the air you breathe in the car is cleaner than that outside when driving in heavy city traffic and tunnels.

Clean Zone Interior Package (CZIP)

CZIP comprises a series of modifications to further improve the interior atmosphere. Materials are chosen carefully to avoid harmful fumes, and surfaces are smooth so they're easy to clean. On days when it's at least 10°C outside, opening the car by remote triggers a 60-second ventilation cycle. This results in cabin air approved by the Swedish Asthma and Allergy Association.

Power glass sunroof

This makes the interior feel extra light and airy. It opens and closes at the touch of a button. If the sun is too strong, just close the built-in sunshade. The sunroof can also be closed together with the side windows using the central locking remote control.

Sun curtain, rear windows

Elegantly integrated in the hatshelf, this transparent sun curtain helps improve in-car climate in direct sun light. Just pull it up and attach it in the roof sealing.

► **Sunshades**

Easily attached to the rear door windows and rear

window, these help reduce the heat and glare of direct sunlight. Simple to remove when they're not needed.

Engine and cabin heater, fuel driven
► **Remote starter**

A fuel-driven heater will make your car easier to start, help reduce environmental impact and warm up the cabin. Start the heater directly, or set the time you'd like to enter your warm and defrosted car. With a remote starter you can activate the heater without going out to the car. And if your car is equipped with Volvo On Call, you can send an SMS to your car from your mobile phone to start the heater.

COMFORT Storage

Front centre armrest, multifunctional

The central aisle of the cabin incorporates several facilities. Two cup holders are concealed by a roll-top cover. There's a handy storage space beneath the armrest, and special recesses for small items. Folding back the upper part of the armrest will provide a convenient table for the rear seat passengers. The armrest also features an AUX input and – depending on your choice of audio system – a USB port to connect your MP3 player to the car's audio system.

Rear centre armrest

Folded down, the rear centre armrest will increase comfort and provide the rear seat passengers with cup holders and smart storage.

Sunglass holder

Fitted in place of any of the entry handles in the front, this holder keeps your glasses or sunglasses within reach.



Driver control interface

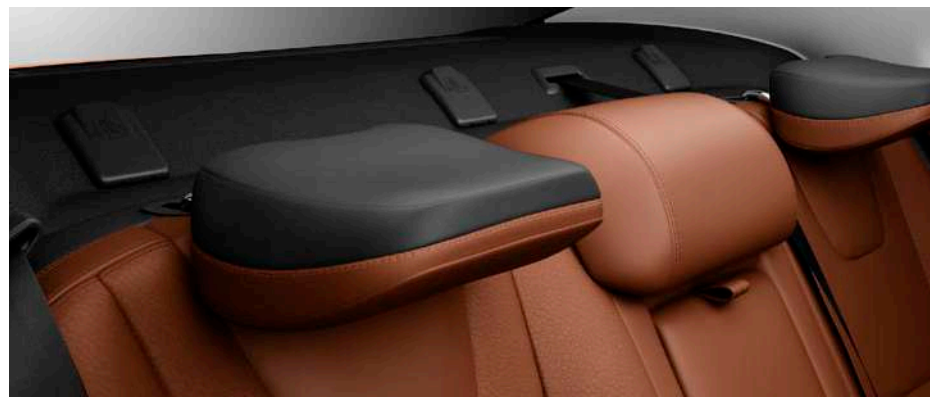

Power foldable rear head restraints



Road and Traffic Information (RTI)



► Park Assist Camera, front blind view



Bluetooth® handsfree system



► Park Assist Camera



► Portable Navigation System

Tech & Sound

TECH & SOUND Driver's Support

Driver control interface

Volvo's new driver control interface allows you to conveniently explore the hi-tech features of your car and personalise them to suit your needs. All information is displayed in a high resolution 5-inch colour screen. A push of the MY CAR button in the centre console gives you access to all system settings like IDIS, City Safety, ACC, Collision Warning, Pedestrian Detection, Driver Alert System, BLIS, light, door mirrors, climate, central locking and audio. Choosing any of the Multi-Media audio systems, the system is upgraded with a larger 7-inch screen which can also display the RTI navigation system, phone, park assist camera, DVD, digital TV etc. Everything is conveniently controlled using the ergonomic steering wheel controls – so you can keep your attention on the traffic and your hands on the steering wheel.

Speed limiter

This helps ensure that you don't surpass a certain speed. Just set a speed using the steering wheel controls. When you reach the set speed you'll be noticed by a small resist feedback from the accelerator. To override the speed limiter all you have to do is press down the accelerator.

Park assist, rear and front

Activated when you engage reverse gear, rear park assist helps you when reversing into tight spaces. The audio system is turned down and a pulsating sound from the rear loudspeakers becomes a continuous tone as you approach an obstacle. Front park assist performs a similar function at the front of the vehicle – alerting you via the front loudspeakers. The remaining distance is also shown on the audio display.

► Park Assist Camera

To further improve your convenience when reversing, the Park Assist Camera helps display what's going on behind your car. The system uses the integrated driver's information screen and a digital camera discretely located over the license plate. On-screen guiding lines provide extra assistance for smooth parking.

► Park Assist Camera, front blind view

Allowing you to see around corners, this new camera is located in the grille to give you a 180° field of vision of the area in front of your car. Activate the camera with a push of a button, and you'll get a split-image view in the 7-inch integrated driver's information screen. Very convenient in tight exits with limited visibility and while parking. Only available in combination with High Performance Multi Media or Premium Sound Multi Media.

Power foldable rear head restraints

Perfect for improving rear visibility when reversing, these are activated by the touch of a button from the driver's seat. The head restraints fold forwards so that rear-seat passengers notice and raise them again when entering the car.

Rain sensor

Once activated, the rain sensor can start the windscreen wipers as soon as it begins to rain or if water splashes onto the windscreen. For your convenience, it can also automatically adapt the intermittent windscreen-wiper function. Its sensitivity can be adjusted via a ring on the wiper stalk.

Automatically dimmed inner rear-view mirror

This is a mirror that automatically adjusts itself to deflect the headlamp beams of the car behind you. When there's no light to dazzle you, it automatically

readjusts to its normal setting. This can be supplemented with an integrated compass.

Power parking brake

The Power Parking Brake (PPB) makes moving off from steep gradients easier. Once depressed, the PPB control lever automatically releases as the car pulls away.

TECH & SOUND Communication

Road and Traffic Information (RTI)

Volvo's GPS-based RTI navigation system is totally integrated with your car. It offers both voice guidance and graphic navigation all the way to your destination. Via TMC (Traffic Message Channel) radio data broadcasts RTI also lets you know if there's weather-related trouble on route and recommends an alternative. The RTI system utilises the integrated 7-inch driver's information display and is easily controlled from the steering wheel or a remote – you can keep both hands on the steering wheel and your attention on traffic. You can also set your destination using voice control.

Extremely swift and precise, the RTI features a hard disc drive covering maps for major parts of Europe. To help you keep track of new roads and points of interest, you can join our MapCare programme for two free map updates.

Only available in combination with High Performance Multi Media or Premium Sound Multi Media.

► Portable Navigation System

This versatile navigation unit integrates smoothly with the design of your Volvo. Just fit it into the docking unit in the windscreen pillar. Touch screen technology allows you to navigate with ease – major buildings and points of interest are displayed in 3D

to enhance your overview, and in junctions you're conveniently guided to the right lane at the right time. Using Traffic Message Channel (TMC) radio data technology, the navigation system will let you know if there are traffic disturbances on route and recommend an alternative. The system also features MP3 player, currency converter, calculator and FM transmitter. And featuring pedestrian mode, the navigation unit is easy to use outside the car. Maps covering major parts of Europe are stored in memory.

Bluetooth® handsfree system

Bluetooth® technology enables a mobile phone to be connected to the infotainment system in your Volvo, wirelessly. Once configured for a mobile phone, the system automatically recognises your phone as you enter the car. And as you climb in and out of the car, the system automatically allows you to switch freely from the phone to the handsfree system and back again. The audio systems High Performance, High Performance Multi Media and Premium Sound Multi Media include an integrated Bluetooth® handsfree system, allowing you to conveniently operate your phone using the buttons in the steering wheel or the centre console keypad. Phone information is shown in the centre console multi media display. And if you've chosen RTI navigation system, you can make your calls using voice control. What's more, you can stream high quality audio from a media player and listen to it through the car's audio system. Available as an accessory for the Performance audio system, there's a voice-controlled Bluetooth® handsfree system that will listen to your command and make calls for you.

The Bluetooth word mark and logos are owned by the Bluetooth SIG, Inc. and any use of such marks by Volvo Car Corporation is under license. Other trademarks and trade names are those of their respective owners.

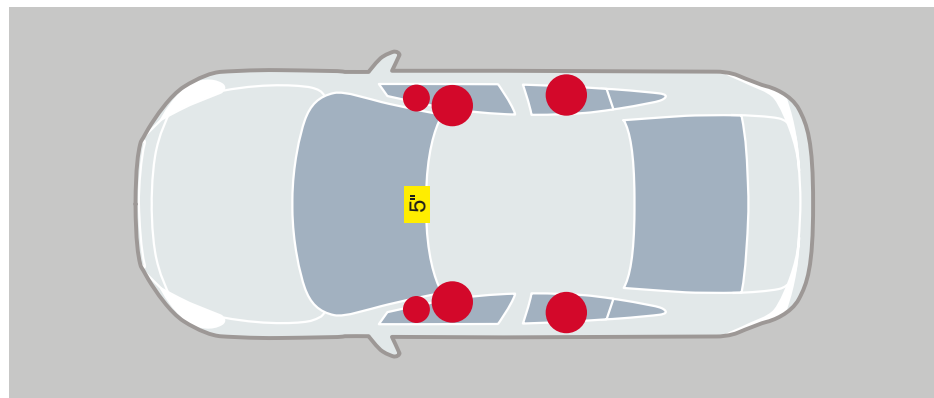

Performance audio system

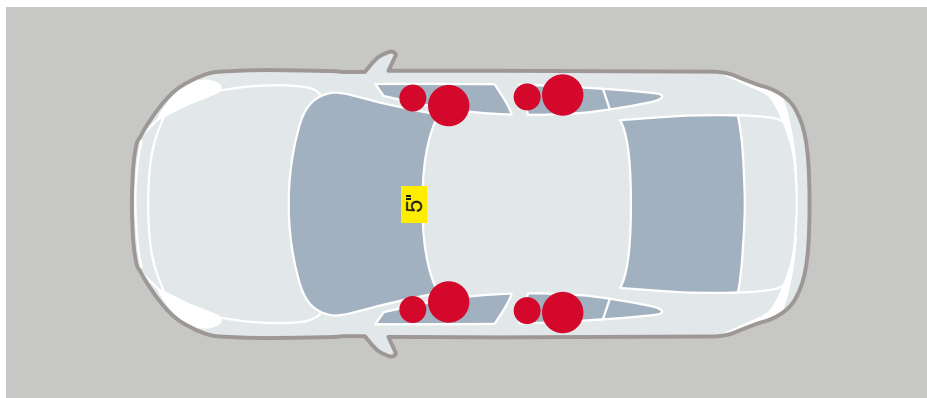

High Performance audio system

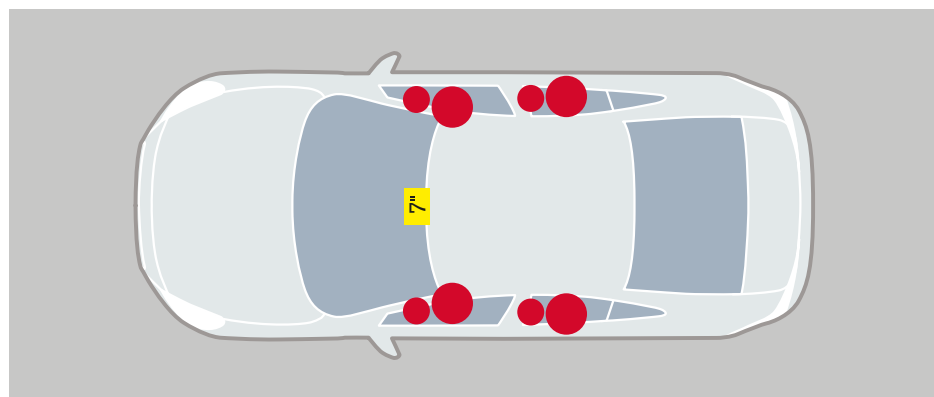

High Performance Audio System Multi Media

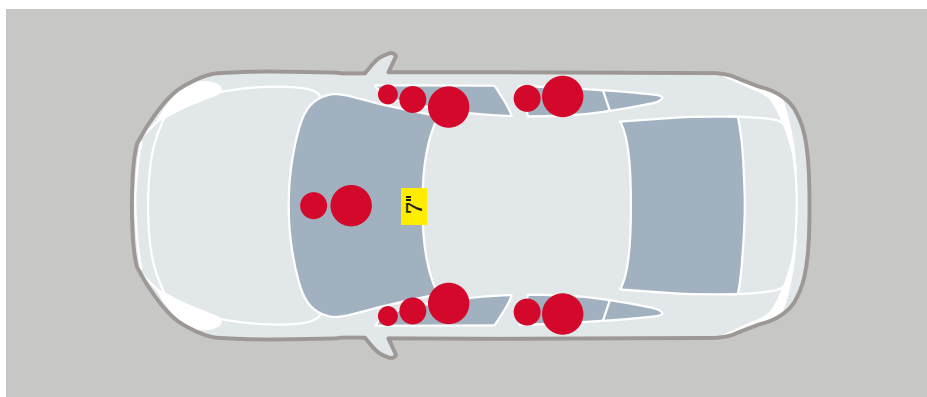

Premium Sound Audio System Multi Media

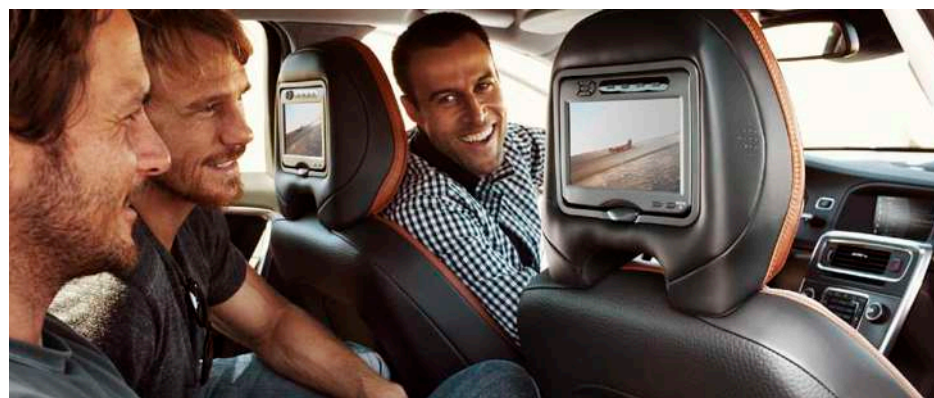

► **Rear Seat Entertainment (RSE) with dual DVD players**



Digital TV

TECH & SOUND Audio

Performance audio system

A console-integrated radio and CD player. It sounds good, looks good and it's easy to use. Performance equipment includes:

- RDS radio
- CD player for CD-audio and audio media files
- AUX input in front centre armrest
- 4x20 W amplifier
- 6 loudspeakers
- 5-inch integrated colour screen

Option: steering wheel integrated controls. Park Assist Camera.

High Performance audio system

This is a powerfully versatile system featuring advanced media technology such as Bluetooth and iPod connectivity. Each loudspeaker is fitted with a more powerful magnet and a larger coil. In combination with the amplifier, this system promotes excellent transient reproduction and high power – quite simply superb sound. This High Performance system includes:

- RDS radio with dual-tuners
- Bluetooth® technology supporting audio streaming and hands-free telephone
- CD player for CD-audio and audio media files
- USB port, iPod® connection and AUX input in front centre armrest
- 4x40 W amplifier
- 8 High Performance loudspeakers
- 5-inch integrated colour screen
- Steering wheel integrated controls with scroll wheel

Options: separate remote control, Digital Audio Broadcasting (DAB), Park Assist Camera, Volvo On Call.

High Performance audio system Multi Media

Above the crisp sound reproduction of the High Performance audio components, this audio level provides an integrated full 7-inch integrated multi-

media colour screen. This transforms your Volvo to a complete platform for the latest in in-car entertainment, communication and navigation technology. For example, you can watch DVD films or terrestrial TV broadcasts when the car is at a standstill. Bluetooth and iPod connectivity further add to the versatility of this system.

High Performance Multi Media includes High Performance audio system plus the following:

- DVD player for DVD-video, CD-audio and video/audio media files
- 7-inch integrated colour screen

Options: separate remote control, Digital Audio Broadcasting (DAB), digital TV, Park Assist Camera, Front view assist, RTI navigation, Volvo On Call.

Premium Sound audio system Multi Media

We designed this top-of-the line audio and infotainment system to give you a superior listening and communication experience. This 5x130 W system features twelve high-fidelity loudspeakers and sound processor technology by Audyssey that optimises the sound reproduction for the interior acoustics. Dolby® Pro Logic® II surround sound helps tailor a well-balanced audio experience for each occupant. And to give you access to advanced in-car entertainment, communication and navigation technology, this system also connects with most media formats and players and features an integrated 7-inch multimedia screen. For example, you can watch DVD films or terrestrial TV broadcasts when the car is at a standstill while enjoying a full-size aural experience. Premium Sound Multi Media includes:

- RDS radio with dual-tuners
- Bluetooth® technology supporting audio streaming and hands-free telephone
- DVD player for DVD-video, CD-audio and video/audio media files

- USB port, iPod® connection and AUX input in front centre armrest
- 5x130 W digital class D amplifier
- Dolby® Pro Logic® II surround sound with centre loudspeaker and digital sound processor
- Dolby® Digital Cinema surround movie sound
- 12 high-end Premium Sound loudspeakers
- 7-inch integrated colour screen
- Steering wheel integrated controls with scroll wheel

Options: separate remote control, Digital Audio Broadcasting (DAB), digital TV, Park Assist Camera, Front view assist, RTI navigation, Volvo On Call.

Dolby, Pro Logic, and the double-D symbol are registered trademarks of Dolby Laboratories.

Premium Sound loudspeakers

The twelve high-end loudspeakers in the Premium Sound system are powered by a 5x130 W digital amplifier. There are three separate drivers – woofer, midrange and tweeter – in each front door. In the rear doors there is a similar set-up. Each speaker has its own crossover filter to harmonise with the others. The latest generation Dolby® Pro Logic® II surround sound uses the centre loudspeakers (woofer and tweeter) and a sound processor to recreate authentic sound with a strong sense of presence for everyone in the car. The digital class D amplifier features new technology to provide extremely high efficiency, enabling it to generate the most audio power from the least amount of current.

MP3 compatibility

There are a number of ways to enjoy MP3 music files in your Volvo. The CD player is compatible with various audio media formats. If you'd like to connect your personal MP3 player to the audio system, there's a standard auxiliary audio input in the front centre armrest. Volume is conveniently controlled from the steering wheel, centre console or rear seat audio console. Choosing the High Performance,

High Performance Multi Media or Premium Sound Multi Media audio system, there's also a USB port that allows you to fully integrate your iPod®, MP3 player or USB device with the audio system. Playlists, songs and artists are clearly displayed in the centre console, while your player will be charged at the same time.

iPod is a trademark of Apple Computer Inc.

Digital Audio Broadcasting (DAB)

Available for High Performance and Premium Sound, a digital radio allows you to share the benefits of Digital Audio Broadcasting (DAB) – the standard for digital radio in Europe. In countries with DAB broadcasts, you'll have access to more radio channels, improved radio reception and near CD-quality sound.

TECH & SOUND Entertainment

► Rear Seat Entertainment (RSE) with dual DVD players

For more fun on long journeys, this easy-to-use system will entertain for hours. There are dual DVD players and dual 7-inch screens smartly integrated in the front head restraints. Each DVD player is conveniently operated by a rear seat passenger. The passengers can see the same movie or play the same game on both screens, or choose to view a film on one screen and play games on the other. Sound is provided via the car's audio system or wireless headphones.

Digital TV

Don't miss your favourite TV show even if you're on the road. Complement your High Performance Multi Media or Premium Sound Multi Media system with this digital TV receiver, and you can watch terrestrial TV broadcasts in the in-dash 7-inch screen when the car is at a standstill. The digital TV is conveniently controlled using the optional remote control.



Two-split 60/40 rear seat
Foldable front seat backrest



► **Towing equipment**



Grocery bag holder



► **Net pockets**



► **Luggage compartment mat, textile**



► **Rear seat cover**

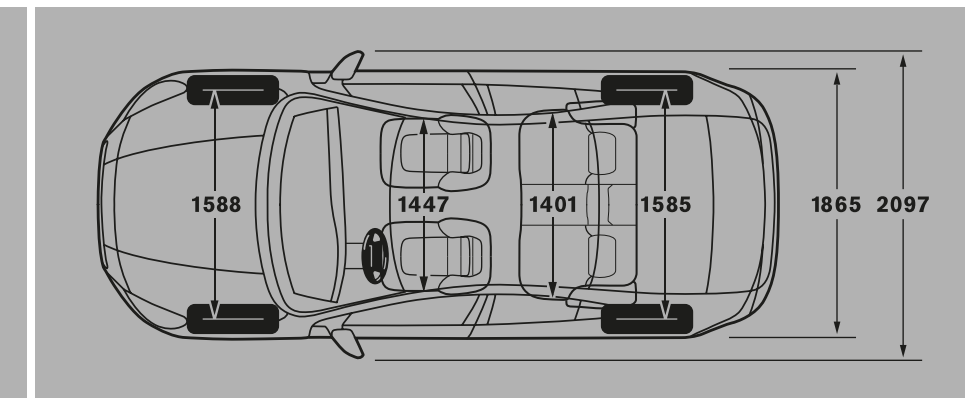
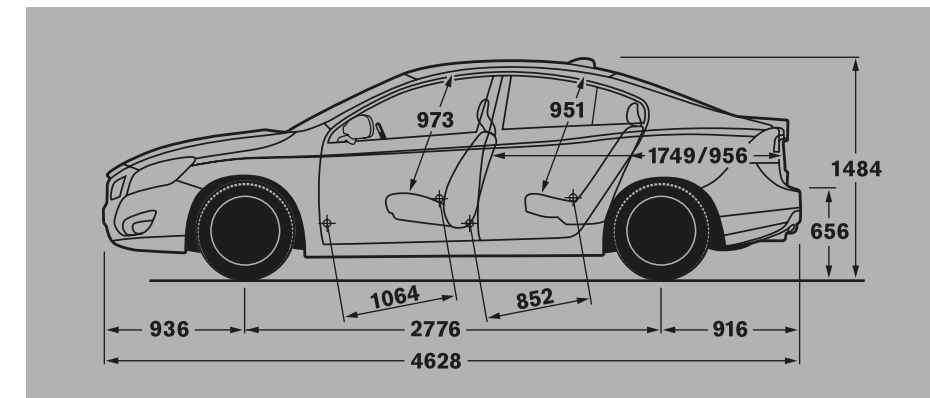

Pack & Load

PACK & LOAD Compartment

Two-split 60/40 rear seat

Ergonomically designed rear seats provide generous support for the body during long journeys. When a journey includes both cargo and passengers, just fold down part or all of the two-split rear seat.

Foldable front seat backrest

To help you carry long objects inside your Volvo, the front passenger seat backrest can be conveniently folded flat.

Grocery bag holder

This integrated holder unfolds from the load compartment floor and keeps your shopping bags and other similar items in place.

► **Net pockets**

These three elastic net pockets provide practical storage for small items on the front passenger side of the tunnel console and along both side panels in the luggage compartment.

► **Luggage compartment mat, textile**

This elegant textile mat allows you to maintain the attractive appearance of the luggage compartment even if you occasionally transport dirty loads. Reversible and waterproof, with colour-keyed textile on one side and plastic on the other.

► **Rear seat cover**

To use the rear seat space as an extra loading area, there's a durable seat cover specially designed for your Volvo. Quickly fitted, this helps protect the upholstery if you need to carry a messy load. It's also

useful if you need to collect a pet or a passenger wearing dirty clothes – safety belts remain operational.

PACK & LOAD Carriers

► **Roof load carrying system**

To help you fully utilise the roof of your Volvo, we've developed a range of versatile load carrying accessories. This system is dimensioned to carry up to 100 kg. The factory-fitted attachment points in the car's roof make the load carriers easy to fit. Various load accessories – such as roof boxes and different holders for bikes, skis, surfboards and kayaks – can be attached to the load carriers to meet your needs. These accessories can be freely combined for flexibility and many are aerodynamically

designed to help reduce fuel consumption and wind noise. And most of them can be locked with the same key, using Volvo's One-Key System.

PACK & LOAD Towing

► **Towing equipment**

A Volvo tow bar – fixed or removable – is the ultimate load accessory. The removable tow bar is easy to detach and refit when necessary. When not in use, it's completely out of the way. A range of tow bar mounted bicycle holders is available – you can take up to four bikes (or two e-bikes) conveniently and safely on the back of your Volvo. Loading is easy, and the holder can be tilted to allow access to the load compartment.



Continuously Controlled Chassis Concept (Four-C)

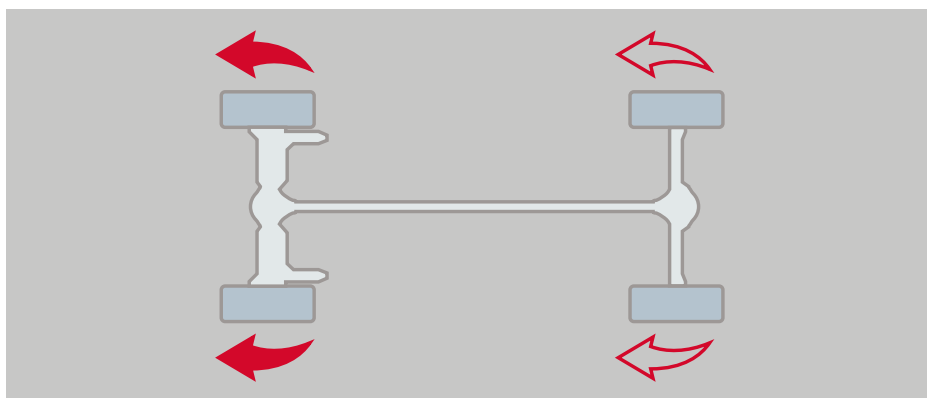

All-wheel drive with Instant Traction™

Performance

PERFORMANCE Chassis/Steering

Chassis

Volvo's chassis engineers spent thousands of hours on all kinds of roads to create a chassis that satisfies even the most demanding driver. Every single detail of the chassis is optimally tuned for sporty and well-balanced handling with a high level of comfort. For you as driver, advanced multi-link rear and McPherson spring strut front suspension mounted on a rigid body with a low centre of gravity translate into a feeling of being in command and in safe control. The front and rear suspensions also interact to provide stable braking and crisp steering. In a curve, the rear wheels have a slight steering facility for added stability and steering response.

Continuously Controlled Chassis Concept (Four-C)

The Four-C active chassis provides a choice of three distinctive driving modes – Comfort, Sport or Advanced. Whichever you choose, this technology monitors the car, road and driver 500 times per second, simultaneously adjusting each shock absorber to maintain optimal handling. At the heart

of Four-C is Volvo's semi-active suspension with continuously controlled Monroe-Öhlins shock absorbers. Furthermore, Four-C interacts with the DSTC system, engine, brakes and steering to promote your chosen handling style.

Comfort This chassis mode isolates the car's occupants from irregularities in the road surface. This setting prioritises flexible dampening for smooth and gentle body movement and exceptional comfort. It's ideal for slippery or uneven roads.

Sport For a sportier experience, this setting prioritises slightly stiffer dampening and acts faster. This results in more decisive body movement, precise handling and good ride comfort. Perfect for active driving.

Advanced This is the high performance mode. This setting stiffens the dampeners for maximum road contact – directly communicating the road surface to the driver. Prioritising immediate feedback rather than comfort, the advanced setting increases the range of driving dynamics.

Speed dependent steering

Speed dependent and progressive power steering uses sophisticated, speed-sensitive technology to

regulate the amount of power assistance a driver needs. At high-way speeds, steering is firmer and more immediate. When parking or in slow traffic, steering is light and effortless. There's a choice of three settings allowing you to choose a suitable level of road feel or steering sensitivity.

PERFORMANCE Transmission

Brake energy regeneration

To further optimise fuel efficiency and performance in all driving conditions, all engines feature Volvo's intelligent brake kinetic energy regeneration. As soon as you brake or release the accelerator while a gear is engaged, the alternator harnesses the car's kinetic energy and feeds it into the battery to reduce fuel consumption with an extra 2–3%. And when you accelerate, the alternator decouples to free the engine for maximum performance when you need it.

Six-speed manual transmission

The six-speed all-synchromesh manual gearbox offers fluid and precise gear selection. The sixth gear improves comfort and fuel economy on the motorway. The smooth action of the clutch assures that you move off with confidence and grace.

Six-speed Geartronic automatic transmission

For the best of two worlds, there's the six-speed Geartronic – a responsive automatic that's ideal for relaxed driving, tough conditions or towing. This also allows manual gear shifting so you can maintain a lower gear to bring up the revs or for the added assistance of engine braking. A special winter setting makes it easier to move off and maintain grip on slippery surfaces.

Six-speed Powershift transmission

Featuring Powershift dual-clutch technology, this six-speed automatic can reduce fuel consumption by 8% compared to a conventional automatic. Gears are shifted instantaneously and torque is delivered without disruption. And if you want, you can also shift gears manually.

All-wheel drive with Instant Traction™

The advanced Haldex AWD technology with Instant Traction™ helps increase driving stability and traction on all road surfaces. It has an electronic management system that constantly monitors the speed of the wheels, the throttle, engine torque, engine speed and the brakes. As driving conditions change, wheels with the best grip get the most power. When a tyre loses traction, power is reduced to that wheel and instantly transferred to the more sure-footed wheels.

	T6 AWD	2.0T	D5 AWD	D5	D3
Engine type:	3.0L I6 petrol twin-scroll turbo	2.0L I4 petrol turbo	2.4L I5 common rail twin-turbodiesel	2.4L I5 common rail twin-turbodiesel	2.0L I5 common rail twin-turbodiesel
Transmission:	Six-speed Geartronic transmission	Six-speed manual or six-speed Powershift transmission	Six-speed Geartronic transmission	Six-speed manual or six-speed Geartronic transmission	Six-speed manual or six-speed Geartronic transmission
Fuel consumption, litres/100 km, mixed cycle, man/auto:	~10.2	7.9/8.0	~7.3	5.9/6.7	5.2/5.8
CO ₂ g/km, man/auto:	~239	184/188	~194	157/177	137/154
Max. power output, kW (hp) at rpm:	227 (304) 5400	149 (203) 6000	151 (205) 4000	151 (205) 4000	121 (160) –*
Max. torque, Nm at rpm:	440/2100–4200	300/1750–4000	420/1500–3250	420/1500–3250	400/–*
Acceleration, 0–100 km/h in sec, man/auto:	~6.5	7.7/8.2	~8.1	7.8/7.8	9.2/9.2
Top speed, km/h, man/auto:	~250	235/230	~225	235/230	220/215
Environmental classification:	Euro 5 (2011)	Euro 5 (2011)	Euro 5 (2011)	Euro 5 (2011)	Euro 5 (2011)
Fuel tank, litres:	67.5	67.5	67.5	67.5	67.5

Technical data may be subject to change. Please talk to your Volvo dealer for the latest information. All technical data is preliminary.
* Technical data not available at the time of printing.

N.B. The engine programme may vary from country to country. Please ask your Volvo dealer for further information.

PERFORMANCE Engines

T6 AWD, six-cylinder turbocharged petrol engine (304 hp)

This sporty in-line 3.0-litre six-cylinder petrol engine meets high expectations for performance, comfort and environmental care. Twin-scroll turbo delivers immediate response at all revs – max torque of 440 Nm is available already from low revs. Fuel saving technology such as brake energy regeneration and reduced internal friction contribute to lower CO₂ emissions and more power. To match the sporty soul of the T6, dual chrome tailpipes are included. This engine's compact design aids safety performance in a frontal collision. The latest generation of fast response emission control technology ensures that the engine complies with stringent environmental standards such as Euro 5.

2.0T, four-cylinder direct injection turbo petrol engine (203 hp)

Featuring the latest direct injection turbo charger technology, this new generation 2.0-litre petrol engine makes it possible to combine supreme performance with low fuel consumption. Considerably increasing combustion efficiency, the fuel is injected with extreme precision. This together with Volvo's brake energy regeneration technology reduces CO₂ emissions, while the turbocharger gives this relatively small engine an extremely high torque (max 300 Nm). As driver, you'll enjoy instant engine response and a relaxed driving experience in all situations. Dual tail pipes add to the sporty character. Of course, this engine complies with stringent environmental standards such as Euro 5.

D5 AWD, five-cylinder turbodiesel (205 hp) D5, five-cylinder turbodiesel (205 hp) D3, five-cylinder turbodiesel (160 hp)

The latest generation five-cylinder D5 and D3 turbodiesels take performance, fuel efficiency and refinement to entirely new levels. Featuring the latest turbo and Piezo high-pressure injector technology, these inspiring five-cylinder state-of-the-art powerplants will give you access to supreme torque (max 420 or 400 Nm) across the rev range. Smooth running characteristics and low noise levels further enhance the experience. The all-new 2.0-litre single-turbo 160 hp D3 is optimised to reduce CO₂ emissions without compromising on comfort or performance – emitting only 137 g CO₂ per km it gives you access to max torque 400 Nm. For a

sportier driving experience with more power across the rev range, the 2.4-litre D5 features a sequential twin turbo. At low revs, a low pressure turbocharger engages to give instant power and a sharp take-off. At higher revs, a high-pressure turbocharger gradually takes over to provide fast overtaking. What's more, there are dual tail pipes for a sportier look. To further optimise engine efficiency in all conditions, these engines also feature Volvo's CO₂ reducing brake energy generation technology. A maintenance-free particle filter effectively reduces soot particles in exhaust gases and advanced emission control contributes to low nitrogen oxide levels – these engines already comply with stringent, upcoming Euro 5 exhaust emission requirements.

Welcome to the club.
The all-new Volvo S60 Merchandise Collection.

Inspired by the world's sexiest Volvo, this smart collection of lifestyle accessories captures the driving spirit of your new Volvo and reflects the best of modern Scandinavian design. The signature items below are a select few. Find more keepsakes, gifts and apparel at your local Volvo showroom and at www.volvocars.com/collection



Watch



iPhone Case



Driving Gloves



Weekend Bag



Nailpolish



Pen



Sunglasses



Card Holder

Notes.

THERE'S MORE TO LIFE THAN A VOLVO.

Volvo. for life



THAT'S WHY YOU DRIVE ONE.

VOLVO

Volvo Car Corporation SP_S60_00008_03-11. English.

Please note: Some of the information in this brochure may be incorrect due to changes in product specifications that may have occurred since printing. Some of the equipment described or shown may now only be available at extra cost. Before ordering, please ask your Volvo dealer for the latest information. The manufacturer reserves the right to make changes at any time and without notice, to prices, colours, materials, specifications and models.