

B-Class



Mercedes-Benz





# First impressions

Life is full of surprises. With the B-Class you can make the most of them – with plenty of beautifully designed space, plenty of attitude, and plenty of forward-thinking technology. For example, the B-Class is packed with the latest electronic assistants, including Collision Prevention

Assist, to ensure you experience a comfortable and safe journey. For a more efficient drive, there is BlueEFFICIENCY technology. It's our way of taking care of a more sustainable future. The B-Class looks smart. Is smart.

[Overview](#) | [from page 4](#)   [Insights](#) | [from page 16](#)

**Featured models:**

---

**B 200 CDI BlueEFFICIENCY Sport | metallic paint** | front cover and from page 2  
18" bi-colour alloy wheels, panoramic sliding sunroof, Active Park Assist, Exclusive Package, Hazelnut Brown leather upholstery, Black Ash wood high-gloss trim

---

**B 180 BlueEFFICIENCY SE | metallic paint** | from page 10  
17" alloy wheels, Intelligent Light System, Domburg fabric upholstery in Grey, Matrix-look trim, luxury automatic climate control, heated seats, rear centre armrest

Specifications shown may include optional equipment and accessories



With an iPhone® or iPad® you can download the interactive B-Class brochure app either by scanning the QR code or by visiting the App Store



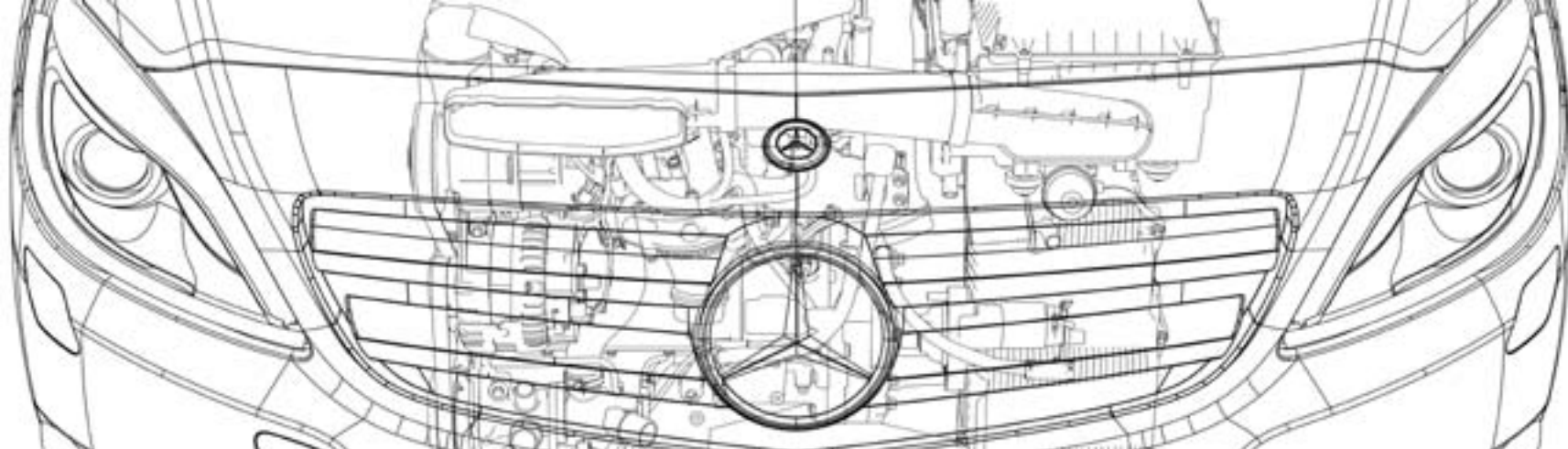

# Facts

**For a pleasant journey:** BlueEFFICIENCY technology, diesel and petrol engines, transmission and suspension.

Engines and suspension | from page 20

**Integrated safety in the B-Class:** 'safer driving', 'anticipating danger', 'protecting occupants' and 'post-crash safety'.

Safety | from page 28

**For everyday luxury:** multimedia systems, electronic assistants, versatility, ergonomic seats, Memory Package and Light and Sight.

Comfort | from page 32

**For endless choice:** model lines, Exclusive Package, comprehensive standard and optional equipment, alloy wheels and Retailer-fit accessories.

Equipment | from page 40

**For the best service:** test drive, Mercedes-Benz Finance and Insurance, Factory Collection, Interactive Owner's Manual, Roadside Assistance and Mercedes-Benz World.

Services | from page 56

**For the finer details:** technical data, dimensions and paint finishes.

Facts and finishes | from page 58



## Space for even the fullest of lives

Whatever you've planned, the B-Class is ready for it. The B-Class provides the comfort required for those longer journeys and the space to carry plenty. Combine this with the joy of driving this exciting Mercedes-Benz with its even sportier, stylish look inside and out. The striking front with high-tech headlights and a ravishing side profile provide plenty of attitude. Pair this with the latest Mercedes-Benz safety systems and you have all the ingredients for a perfect day on the road.

B-Class Sport with optional panoramic sliding sunroof, Active Park Assist and metallic paint



# Room for five and your inspiration



B-Class Sport with optional panoramic sliding sunroof, Active Park Assist and metallic paint





B-Class Sport with optional panoramic sliding sunroof, Active Park Assist and metallic paint



Your favourite song is on the radio, your friends in the rear provide you with the latest gossip. Sometimes one pair of eyes just doesn't seem enough to stay completely focused. To make sure you're well equipped for what's ahead, the B-Class is fitted with Collision Prevention Assist as standard – a first for a car in this class. This system constantly watches the road without ever getting distracted by events elsewhere. And with the possibility of up to ten other electronic assistants on board, it's just one of many ways the B-Class looks out for you. → Page 28, 29, 34, 35

Always looks where you're going



B-Class Sport with optional panoramic sliding sunroof, Active Park Assist and metallic paint



Compact enough to fit in most parking spaces, spacious enough to accommodate all your adventures. The 488-litre load compartment provides plenty of room for your weekly shopping, luggage or pushchair. Need more space? Simply opt for the Easy-Vario-Plus Package. For all your smaller items, there are clever storage compartments throughout, and should you need further space to keep those important items safely packed away, you can opt for the Storage Package. Needless to say, you and your passengers will enjoy lots of room to stretch your legs. → Page 36, 37

Interior shown includes optional luxury automatic climate control, COMAND Online system, Exclusive Package, Memory Package, Harman Kardon® Logic 7® surround sound system, automatic transmission and rear centre armrest









Whether you choose Jupiter Red or Cirrus White, there are blue skies ahead

With the B-Class you're always one step ahead. By saving fuel and reducing emissions, recycling materials and protecting resources, we're helping you look after the future. In addition to the standard BlueEFFICIENCY and ECO start/stop technologies, the B-Class also features one of the best drag coefficients around, making it even more efficient – what ever paint finish you choose. → Page 20, 21

B-Class SE shown in optional metallic paint with optional bi-xenon headlamps, LED daytime running lights and alloy wheels



Everyone loves surprises, but wouldn't you like to know what's around the corner?



B-Class SE shown in optional metallic paint with optional bi-xenon headlamps, LED daytime running lights and alloy wheels





Brains and beauty

B-Class SE shown in optional metallic paint with optional bi-xenon headlamps and LED daytime running lights







Wherever life takes you, with the B-Class you're travelling in style. Choose the B-Class SE for comprehensive standard equipment including leather steering wheel, chrome styling and Active Park Assist. The B-Class Sport stays true to its name with features such as 18" bi-colour alloy wheels, lowered comfort suspension, Direct Steer system, bi-xenon headlamps and privacy glass. For further luxuries, the optional Exclusive Package has sumptuous leather and wood trim. Whether you prefer stylish chrome details throughout the cabin, heat-insulating privacy glass or beautiful ambient lighting, the B-Class' attention to detail creates a unique atmosphere of well-being. → Pages 40–53



## Hitting the wall 700 times over

Crashing and smashing is part of our daily routine in the Mercedes-Benz 'crash hall': we're experts at light collisions, heavy ones, frontal and rear impacts, side and top crashes. This gives us the data for designing the best possible collision protection for our cars. In carefully prepared laboratory tests, our engineers crash prototypes against the wall more than 700 times a year. While crash tests are the more spectacular side of the Daimler safety philosophy, our integrated safety concept

combines many active and passive safety systems so that you can safely master any traffic situation, but especially when anticipating a possible accident and reducing its severity if the worst comes to the worst. For example, Collision Prevention Assist monitors the area in front of the car using radar technology. It can alert the driver in time about potential accidents ahead at speeds of 20 mph and more, allowing a dangerous situation to pass you by without a trace.





## Now a feature in all the best families

Let's face it – smaller passengers often forget their manners. They work on their singing career during the rush hour, redesign your rear seats with biscuit crumbs, or pull faces at fellow drivers at the traffic light. They simply do what they do best: being a child.

If you're looking for a relaxed and uninhibited environment where you and your passengers can be yourselves, get into the B-Class. The carefully crafted interior provides a cosy home from home with heat-insulating privacy glass for the rear windows (standard on the Sport). All the world will get to see is a striking car with a truly respectable family inside.



**20 BlueEFFICIENCY****21 B-Class BlueEFFICIENCY****22 Diesel engines**

4-cylinder

**24 Petrol engines**

4-cylinder

**26 Transmissions**

6-speed manual transmission

7G-DCT 7-speed dual-clutch automatic transmission

**27 Suspension**

Suspension and steering

Lowered comfort suspension

Direct Steer system

**28 Integrated safety concept**

Attention Assist

Adaptive Brake

Distronic Plus

Lane-Tracking Package

Intelligent Light System

Collision Prevention Assist

Pre-Safe® system

Restraint systems

Mercedes-Benz Emergency Call System

Post-crash safety

**32 Multimedia systems**

COMAND Online system

Audio 20 radio/single CD

Media Interface

Becker® Map Pilot navigation system

Harman Kardon® Logic 7® surround sound system

**34 Electronic assistants**

Reversing camera

Active Park Assist including Parktronic

Speed Limit Assist

**36 Versatility**

Rear seats

Load compartment

Easy-Vario-Plus Package

Load Compartment Package

**38 Seats and Memory Package**

Seats

Seat Comfort Package

4-way lumbar support for driver and

front passenger

Memory Package

**39 Light and Sight**

**40 Model variants**

B-Class SE

B-Class Sport

Exclusive Package

**50 Standard equipment****51 Optional extras****52 Alloy wheels**

Standard alloy wheels

Optional alloy wheels

**54 Retailer-fit accessories****56 Services**

Test drive

Mercedes-Benz Finance and Insurance

Factory Collection

Interactive Owner's Manual

Roadside Assistance

Mercedes-Benz World

**58 Dimensions****59 Technical data****61 Paint finishes**

## BlueEFFICIENCY – technology for more efficient driving

Our comprehensive BlueEFFICIENCY measures have already brought significant cuts in fuel consumption to many current Mercedes-Benz models, helping to lower both their CO<sub>2</sub> emissions and their running costs. What's more, we are continuing to develop new environmentally friendly technologies that will reduce emissions even further and help to make motoring more sustainable in the long term.

### **BlueEFFICIENCY – the Mercedes-Benz efficiency drive.**

BlueEFFICIENCY models feature a range of measures that can considerably reduce fuel consumption and CO<sub>2</sub> emissions. They include aerodynamic optimisation, low-resistance tyres and intelligent energy management technologies such as the ECO start/stop function, which comes as standard on the majority of our passenger car models. Many of our model ranges also now offer new BlueDIRECT engines. Their innovative direct petrol injection system delivers significantly more power, yet also helps to cut fuel consumption by up to 25%.

**BlueTEC – cleaner diesel power.** BlueTEC is our cleanest diesel technology to date. Its combination of advanced common-rail direct injection, optimised combustion and modular emissions control systems reduces particulate levels by up to 95% and removes up to 90% of nitrogen oxides, leaving little but water and nitrogen.

### **HYBRID – internal combustion at its most intelligent.**

Our hybrid system combines a conventional petrol engine with an electric motor that boosts acceleration and enables brake energy to be recuperated and stored in the battery. In addition, our latest-generation hybrid models offer all-electric propulsion at up to approx. 20 mph, as well as the ability to 'glide' at speeds of up to 100 mph, by shutting down the combustion engine for maximum efficiency and zero emissions. In the E-Class, this advanced hybrid technology can also be enjoyed in diesel form, thanks to the new E 300 BlueTEC HYBRID.<sup>1</sup>

**E-Cell and F-Cell – new drivetrain concepts.** We've also already rolled out limited production runs of two all-electric vehicles with zero local emissions: the A-Class E-Cell<sup>2</sup> and the B-Class F-Cell.<sup>2</sup> The F-Cell uses a hydrogen fuel cell to drive its electric motor, while the E-Cell is powered solely by twin lithium-ion batteries. Our F 125! F-CELL Plug-In HYBRID, meanwhile, demonstrates the possibilities of innovative zero-emission motoring for luxury vehicles.

**Design for Environment.** Our environmental philosophy is not just about in-car technologies. It also involves taking the entire lifecycle of each vehicle into account, from its initial planning to its end-of-life recycling. In addition, Mercedes-Benz is involved in the development of alternative fuels and conducts research in the field of bionics.

For more information about our holistic approach, see [www.mercedes-benz.co.uk/blueefficiency](http://www.mercedes-benz.co.uk/blueefficiency)

<sup>1</sup>E 300 BlueTEC HYBRID Saloon: Euro 5 emissions rating. Fuel consumption, urban: 65.7–67.3 mpg; extra-urban: 65.7–67.3 mpg; combined: 65.7–67.3 mpg; combined CO<sub>2</sub> emissions: 112–109 g/km; efficiency rating A+ <sup>2</sup>Provisional efficiency rating A+  
Figures obtained in accordance with the prescribed measuring process (Regulation 715/2007/EC in the currently applicable version). The figures are not based on an individual vehicle and do not constitute part of the product offer; they are provided solely for purposes of comparison between different vehicle models



## B-Class BlueEFFICIENCY

With its comprehensive sustainable approach, the B-Class combines performance and dynamics with pioneering efficiency technologies and innovative measures to reduce both fuel consumption and harmful emissions.



Every B-Class comes with BlueEFFICIENCY as standard. As a testament to its green credentials ranging from the manufacturing process through to its recycling measures, the B-Class has been awarded with the environment certificate 'Design for Environment' (ISO/TR 14062).

BlueEFFICIENCY covers a range of measures:

- 1 Energy-saving ancillaries
- 2 Adjustable radiator shutters and intelligent oil pump management
- 3 Highly efficient generator
- 4 Engines with petrol direct injection; optimised diesel engines
- 5 Air-conditioning compressor feature
- 6 Enhanced aerodynamics. Improvement by 13% compared to previous model (drag coefficient 0.26)
- 7 ECO start/stop function
- 8 Driver information to encourage fuel-efficient driving
- 9 Euro 5 emissions standard across the range
- 10 Tyres designed for lower rolling resistance
- 11 7G-DCT 7-speed dual-clutch automatic transmission (optional)



## Diesel engines

Cleaner, more efficient, more powerful: The B-Class is a showpiece for Mercedes-Benz diesel technology. The engines are quiet yet bursting with energy, offering low fuel consumption and reduced emission levels.

**4-cylinder diesel engines.** The 4-cylinder diesel engine offers a torque performance and an impressive response even at a low engine speed, while also ensuring improved fuel efficiency and reduced CO<sub>2</sub> emissions.

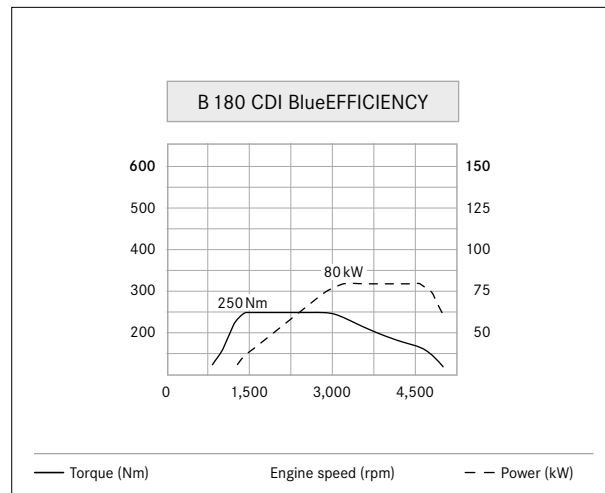

The B 180 CDI BlueEFFICIENCY engine reaches maximum torque between 1,400 and 2,800 rpm

Noise and vibration levels have also been significantly reduced. The key to this impressive set of achievements is a combination of advanced technologies. The engines' fourth-generation common-rail system boasts ultraprecise magnet valve injectors, increased pressures of 1,800 bar and further optimised combustion chambers. The higher ignition pressure and turbocharging mean high levels of torque are available at any engine speed.

A whole range of measures helps to further increase overall vehicle efficiency of the B-Class. These include tyres with lower rolling resistance, improved aerodynamics and intelligent ancillary unit management. In addition, the current engine generation boasts impressive performance and high levels of torque whilst keeping fuel consumption and CO<sub>2</sub> emissions low.

But that's not all: the standard ECO start/stop function automatically switches off the engine at traffic lights or in a traffic jam. The standard ECO display keeps the driver informed about efficiency and encourages an economic driving style. Both diesel engines meet the Euro 5 standard for exhaust emissions.

There are two 4-cylinder diesel engines to choose from:

- B 180 CDI BlueEFFICIENCY - 107 hp (80 kW) with 250 Nm maximum torque
- B 200 CDI BlueEFFICIENCY - 134 hp (100 kW) with 300 Nm maximum torque



The 4-cylinder B180 CDI BlueEFFICIENCY diesel engine combines high levels of torque with low fuel consumption and reduced emissions



## Petrol engines

The petrol engines deliver on all fronts: they boast significantly lower fuel consumption and reduced CO<sub>2</sub> emissions, with performance continuing to be impressive.

**4-cylinder petrol engines.** Direct petrol injection, variable valve control and turbocharging help this 1.6-litre 4-cylinder petrol engine to deliver high levels of power and torque along with low fuel consumption and

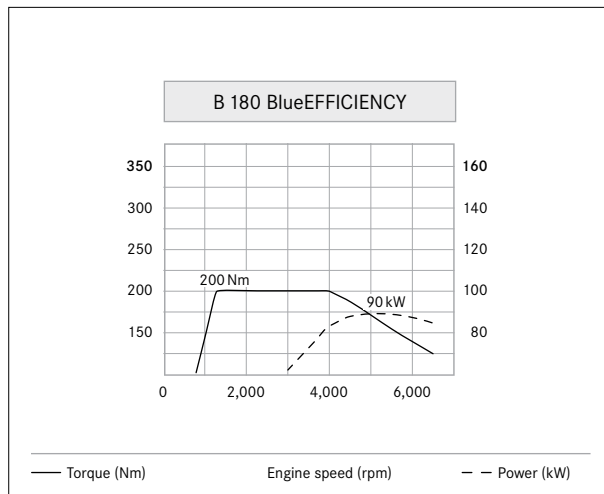

The B 180 BlueEFFICIENCY offers 200 Nm maximum torque between 1,250 and 4,000 rpm

emissions, as well as reduced noise and vibration levels.

For higher combustion efficiency and performance which, in turn, guarantees lower fuel consumption, the refined combustion system works with direct petrol injection and highly precise piezo injectors. Variable camshaft control ensures precisely the right amount of fuel is used for any given situation. Weight-savings and lower internal friction also help to further reduce fuel consumption.

But that's not all: the standard ECO start/stop function and the ECO display both help the driver to further reduce consumption. As soon as the car is stationary, at a traffic light or in a traffic jam, the engine is switched off to save fuel and to lower CO<sub>2</sub> emissions.

The petrol engines also benefit from BlueEFFICIENCY measures to reduce the warming up phase, intelligent oil pump management and a highly efficient generator.

There are two 4-cylinder petrol engines to choose from:

- B 180 BlueEFFICIENCY with 121 hp (90 kW) with 200 Nm maximum torque
- B 200 BlueEFFICIENCY with 154 hp (115 kW) with 250 Nm maximum torque

Both 4-cylinder B-Class petrol engines meet the current Euro 5 emissions standards.





The B180 BlueEFFICIENCY 4-cylinder petrol engine features direct injection with piezo injectors and turbocharging



## Transmissions

Whether you choose the 6-speed manual or the 7G-DCT 7-speed dual-clutch automatic, both transmissions are tailor-made to suit the B-Class' individual engines with optimised weight and excellent levels of performance and drive comfort.

**6-speed manual transmission** (standard). All engines come with our 6-speed manual transmission combined with ECO start/stop function as standard. The 6-speed manual transmission benefits from short, precise shift throws while the transmission ratios are ideally matched to the engine and the final drive ratio. The ECO start/stop function temporarily switches the engine off when the car is coming to a standstill, for example, at a red traffic light, or when in a traffic jam. It restarts as soon as you touch the accelerator or depress the clutch. Additionally, a shift point indicator and current fuel consumption display helps you to drive more efficiently.

**7G-DCT 7-speed dual-clutch automatic transmission** (optional). The dual-clutch transmission achieves a unique combination of comfort, sportiness and efficiency. It consists of two part-transmissions, each featuring its own clutch. One is responsible for the 'even' gears, the other takes care of the 'odd' ones. During acceleration or braking, the transmission that is currently not in use will preset the next higher or lower gear. When changing gear, the system switches to the currently inactive transmission. As a result, gear changes are delivered faster without loss of throttle. Both clutch and gear changes are fully automatic to ensure significantly smooth gear shifts. The driver can choose between 'Economy', 'Sport' and 'Manual' modes to suit their individual driving style. The 'Sport' mode, for example, will choose a higher gear at higher revs than in 'Economy' mode, and lower gears are activated sooner. For an even sportier driving style, drivers can shift gears via the 'Manual' mode, or use the steering wheel shift paddles.

For greater efficiency, the transmission also features ECO start/stop function. Additionally, an ergonomic Direct Select gear shift lever, Cruise Control and Speedtronic are also standard on the 7G-DCT 7-speed dual-clutch automatic transmission.



Comfortable gear shifts without throttle disruption: the 7G-DCT



# Suspension

Whatever suits your B-Class model. A suspension system to match.

**Suspension and steering.** Completely redesigned and optimised, the suspension combining McPherson front axle and four-link front suspension ensure optimum road holding and ride comfort. The standard rack-and-pinion steering system with integrated Steer Control offers precise handling in critical driving situations. For additional comfort and safety, the electro-mechanical power steering decreases at increased speeds.

**Lowered comfort suspension with Direct Steer system** (as part of the B-Class Sport). The lowered comfort suspension with selective dampers combines agility and drive safety with excellent body control. The lowered comfort suspension has a sporty setup for even more direct response, resulting in agile handling and a dynamic driving sensation. The body is additionally lowered by 15 mm.

**Direct Steer system** (as part of the B-Class Sport). Featuring an innovative spur rack, this system blends driver comfort and safety with a sporty edge. Working together with the suspension system, the Direct Steer system allows a more spontaneous response to steering movements. At lower speeds, in tight corners or, when parking, for example, very little steering effort is required. At higher speeds, straight-line stability is outstanding.



## Integrated safety concept

Like all our passenger cars, the B-Class is built according to an integrated safety concept. It ensures the many passive and active protection systems work together to enhance safety in every situation – helping to bring our vision of accident-free driving another step closer.

As the inventor of the motor car, we feel a particular responsibility towards road safety. That's why we were the first manufacturer to develop an integrated safety concept that seamlessly combines a car's active and passive safety features, thus ensuring optimum all-round protection. This concept covers four different areas – safer driving, anticipating danger, protecting occupants and post-crash safety – and incorporates measures designed to maximise safety in every situation, by helping you to stay safe, alerting you to danger, and assisting you wherever possible. In addition, our unique Pre-Safe® anticipatory safety system recognises likely accident scenarios and takes steps that help to further enhance occupant protection. If a collision can't be avoided, intelligent passive safety systems help to provide protection where it's needed, while solutions that can minimise the consequences of an accident and facilitate emergency assistance are also a key part of this safety concept. A selection of these technologies for the phases 'safer driving', 'anticipating danger', 'protecting occupants' and 'post-crash safety' are presented on the following pages.

**Safer driving: Attention Assist** (standard). If it detects signs of tiredness, Attention Assist alerts the driver via visual and acoustic warnings and recommends taking a break. It monitors driver behaviour via an array of sensors and registers unexpected changes that may indicate drowsiness or concentration lapses.



Attention Assist recommends a break when the system detects tiredness or a lack of concentration

**Safer driving: Adaptive Brake** (standard). In conjunction with anti-lock braking system (ABS), this modular driving dynamics system helps improve traction and drive comfort, enhancing the B-Class' safety performance in critical driving situations. It includes automatic brake drying for driving in wet conditions, ensuring a faster reaction to the pedal and thus a shorter stopping distance. By priming the brakes, the system automatically moves the brake pads into surface contact with the brake discs when the driver suddenly takes the foot off the accelerator. This enables the brakes to engage fully and firmly in less time. During hill starts, the system helps prevent unintentional rolling backwards when switching from brake pedal to accelerator. Additionally, the hold function, activated by pressing the pedal twice, holds the car stationary, even if the driver takes the foot off the brake pedal.

**Safer driving: DISTRONIC PLUS** (optional). DISTRONIC PLUS radar-assisted cruise control helps you to maintain the required distance from the vehicle in front. The system works between standstill and 124 mph and for distances between 8 inches and 200 yards, applying the brakes automatically (bringing the car to a standstill if necessary) and accelerating again once the situation allows. This also makes it useful in city and stop/start traffic. DISTRONIC PLUS is only available in conjunction with the optional 7-speed, dual clutch 7G-DCT transmission.

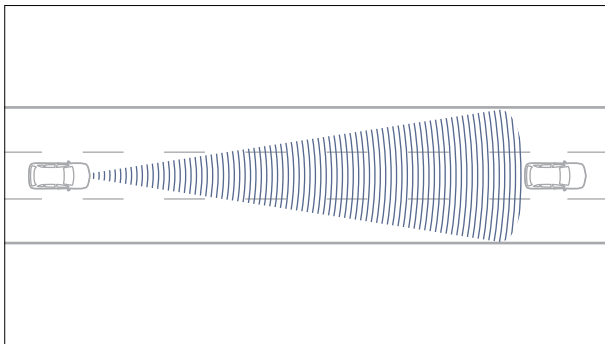

DISTRONIC PLUS helps the driver keep the required distance to the car in front

**Safer driving: Lane-Tracking Package** (optional). Lane-Keeping Assist recognises white road markings and warns you via subtle vibrations of the steering wheel should you unintentionally stray out of lane. Blind Spot Assist, meanwhile, uses twin radar sensors to monitor the hard-to-see areas either side of the rear. In lane changes at speeds of approximately 20 mph or above, the system can detect the presence of another vehicle in your blind spot and alert you to the danger via a symbol in the relevant exterior mirror.

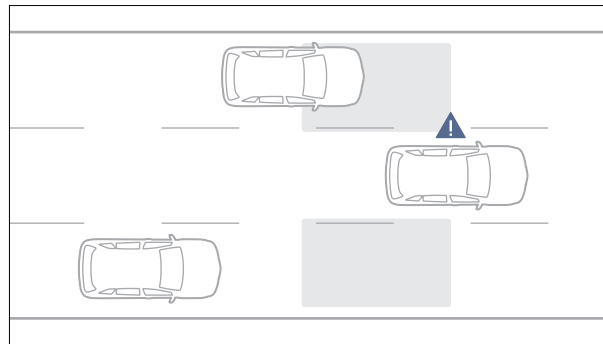

Lane-Keeping Assist/Blind Spot Assist are designed to warn the driver about potentially dangerous situations

**Safer driving: Intelligent Light System** (optional). The Intelligent Light System comprises a variety of modes and functions that help your visibility at night or in other low-visibility conditions. Country mode and motorway mode adjust the light to suit the road, while the Active Light System enables the beams to follow your steering angle. Also included is Adaptive High Beam Assist, which dips the headlamps automatically when on high beam, if the lights of an oncoming vehicle are detected. Additionally, the chrome-trimmed LED daytime running lights in the front bumper and LED tail lights, further enhance visibility on the road.

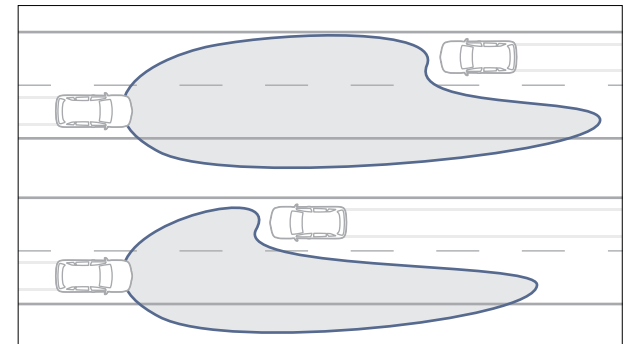

The Intelligent Light System automatically adapts to changing light and driving conditions



### Anticipating danger: Collision Prevention Assist

(standard). Collision Prevention Assist can alert the driver if the distance to the vehicle in front decreases with unusual rapidity, thereby helping you to avoid front-end shunts. The radar-assisted warning system works from speeds around 20 mph. When the brakes are then applied, the Adaptive Brake Assist function can automatically increase the brake force if necessary, ensuring the available stopping distance is exploited to the full and thereby increasing the chances of avoiding an impact.



Collision Prevention Assist alerts the driver via acoustic and visual warning if the distance to the car in front becomes too low.

**Anticipating danger: Pre-Safe® system** (optional). If it detects a probable accident scenario, Pre-Safe® can take a range of anticipatory measures to reduce the risk of injury to the occupants. Triggered by events such as emergency braking, these can include activating the front seat belt tensioners and automatically closing the windows and sunroof (if fitted), ensuring maximum protection from airbags and seat belts should an impact then occur.

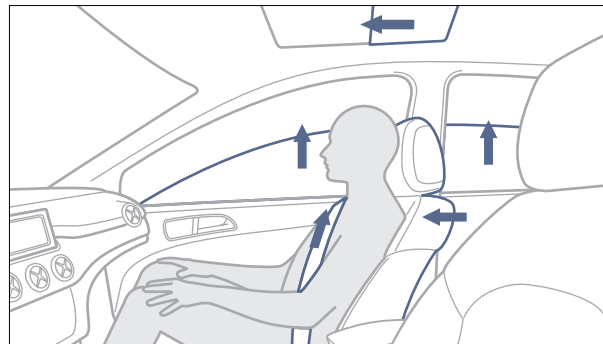

The Pre-Safe® system helps to enhance safety belt and airbag performance

**Protecting occupants: restraint systems** (standard).

The 3-point seat belts, seat belt tensioners, belt force limiters and airbags are all carefully coordinated so as to keep injuries to a minimum. In addition to the rigid passenger cell, seven standard airbags further reduce the risk of injury: dual-stage front airbags, which are triggered according to the severity of the impact, windowbags, pelvisbags for driver and front passenger, and a driver's side kneebag. Sidebags for rear seat occupants are available as an option. If the crash sensors detect an impact, the seat belts are instantly tensed, helping to ensure the occupants remain firmly in their seats, while the belt force limiter relaxes the belt as the situation allows, in order to prevent undue force being applied to the rib cage.

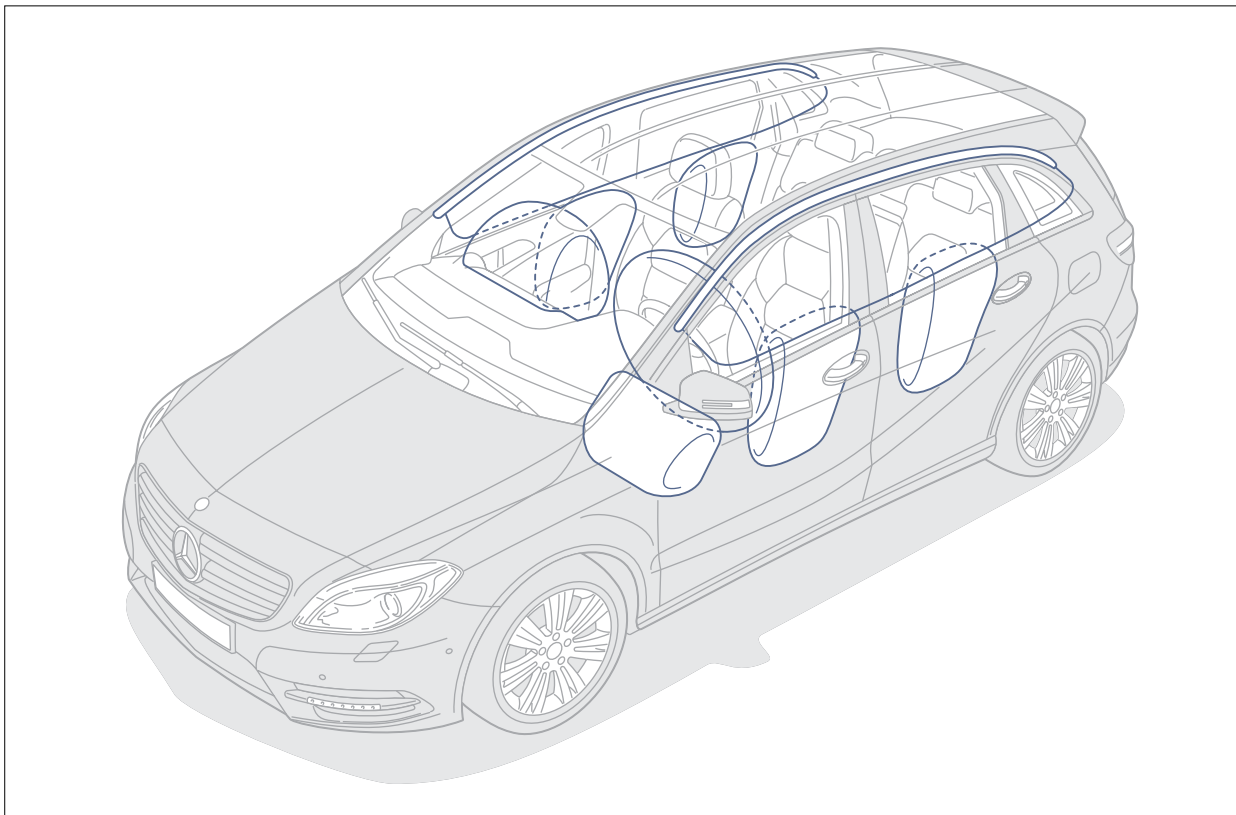

Seven airbags help to significantly reduce the risk of injury in a collision

### Post-crash safety: Mercedes-Benz Emergency

#### Call System (part of optional COMAND Online system).

If the restraint system detects a collision, it automatically makes a call to the Mercedes-Benz emergency call centre with the position and data of the car. The centre then makes a voice connection to the car. The emergency call can also be made manually.

**Post-crash safety.** Mercedes-Benz has developed a range of measures that help to minimise the secondary consequences of an accident and facilitate occupant rescue. These include automatic engine cut-off, self-activating hazard lights and emergency cabin lighting. In addition, the central locking system is automatically released in the event of an accident, and there are special crash joints between the front doors and wings that make it easier to open the doors after frontal collisions. In addition, Mercedes-Benz provides a rescue guide for emergency services that can be downloaded from the Internet at [www.mercedes-benz.co.uk/rescueguide](http://www.mercedes-benz.co.uk/rescueguide)



## Multimedia systems

The B-Class offers plenty to keep you entertained: Audio 20 radio/single CD, the optional Becker® Map Pilot navigation system, COMAND Online or Harman Kardon® Logic 7® surround-sound system with Media Interface.



COMAND Online is your all-in-one gateway to audio, navigation and communication featuring a high-resolution 7-inch display

**COMAND Online system** (optional). The COMAND Online multimedia system combines hard-drive navigation with in-car Internet access and a wide range of entertainment features. These include speed-sensitive volume adjustment, a music library with 10 GB of storage space for audio files and a DVD drive that plays CDs, MP3s, and video or audio DVDs. It also enables you to connect a variety of external devices and storage media – via USB port, Media Interface, SD memory card slot or Bluetooth® interface – and lets you access the Internet as well as a variety of Mercedes-Benz Online services (Internet-enabled mobile phone required). Maps and menus are presented on a high-resolution 7-inch colour display, and all key functions can be operated either via the central controller, from the multi-function steering wheel or using Linguatronic voice control. Three years of map updates are offered free of charge.





**Audio 20 radio/single CD** (standard). The Audio 20 system offers all the key features of a modern in-car entertainment system: radio, CD drive, MP3, WMA and AAC playback, USB port, aux-in socket and Bluetooth® interface. It also comes with a larger 5.8-inch central display and can be further enhanced with options such as a 6-disc CD changer and our Media Interface. Whilst all Audio 20 radio/CD functions can be operated via the central controller, the aux-in socket and USB port are located in the centre armrest for your convenience. Additionally, six speakers throughout the cabin ensure excellent sound quality.

**Media Interface** (optional). The improved Media Interface is perfectly matched to mobile audio devices such as Apple iPod®. As the folder structure of the player is copied over to the Interface and the music transferred digitally, tracks can be quickly changed and the titles displayed.

**Becker® Map Pilot navigation system** (optional).

Becker® Map Pilot can be integrated with the Audio 20 radio/CD system's central controller and display, turning it into a fully featured 3D map navigation system. Downloading additional functions and map updates helps you tailor it to your needs. You can operate the system using voice recognition, via the central controller, or from the multi-function steering wheel. The control unit can be quickly secured and connected via a plug-in port in the glove compartment and removed at any time.



The Becker® Map Pilot navigation system shows vital information both via the Audio 20 radio/single CD display, and the multi-function colour display

**Harman Kardon® Logic 7® surround sound system**

(optional). With its 12 high-performance speakers and Logic 7® multi-channel spatial sound technology, this 450-watt surround sound system with 9-channel DSP-amplifier makes every journey a listening experience to remember. Combined with COMAND Online, it also features a Dolby-Digital 5.1-system. Additionally, the system can be adjusted to provide the perfect surround sound for specific areas of your B-Class, for the entire cabin, front, centre or rear area.



Concert-like sound quality is delivered by the Harman Kardon® Logic 7® surround sound system



## Electronic assistants

It's not just safety features that premier in the B-Class. There are also plenty of new electronic assistants designed to keep you relaxed and safe.

**Reversing camera** (standard on Sport, optional on SE). This rear-mounted wide-angle camera makes for safer and easier parking manoeuvres. Activated automatically as soon as the driver engages reverse, it captures the area immediately behind the car and enables you to see the image on the dashboard's central display (or in the COMAND Online display, if fitted).



The central display shows the area behind the car during a parking manoeuvre

**Active Park Assist including Parktronic** (standard on SE, optional on Sport). Active Park Assist can assess parallel parking spaces as you drive and, if it finds one that fits, it'll even help you steer the car in. When driving at up to 20 mph, the system will recommend a parking space. Once this is approved by the driver and the car is in reverse, the system parks the car at a touch of a button. All the driver has to do, is apply the clutch, brake and accelerator, the car does the steering for you.



The multifunction display informs the driver about the current parking process

The improved system now works even more precisely: For the automatic parking procedure, the parking space has to be just 1.3 metres longer than the vehicle. And parking in a bend has been optimised. Working with 10 Parktronic ultrasound sensors, placed at the front and the rear of the vehicle, and a control unit to calculate the best possible parking angle and parking space. The car can even steer automatically out of the space. The driver only has to operate the accelerator and brake pedals and pay attention to the traffic. Leaving the parking space is activated by the button on the steering wheel once the engine has been started and the turning indicator set.



**Speed Limit Assist** (fitted with the optional COMAND Online system). This system reads speed limit signs and displays the permitted maximum speed in the car's instrument panel until the limit changes. Its front-mounted camera detects signs mounted above the carriageway as well as those by the side of the road and is particularly useful in areas where the speed limit varies or when passing through roadworks. To help identify the limit correctly, it compares speed limit signs with map data from the navigation system, enabling it to recognise when you are entering or leaving built-up areas, for instance. Speed Limit Assist not only helps the driver stay within the speed limit, it also enhances driving comfort, especially on longer journeys with frequently changing speed limits.



The Speed Limit Assist alerts the driver to the current speed limit



## Versatility

Because no day is the same: the rear seats and the load compartment are designed to adjust to your varying needs.

**Rear seats.** The B-Class greets rear passengers with ample legroom and head restraints for all three rear seats (with the middle one designed to give the driver optimum visibility). The outer seats feature ISOFIX child seat points with top-tether anchorage points. Two integrated child seats for the outer seats with removable head restraints are available as an option.



The B-Class helps you create an almost completely flat luggage area in seconds

**Load compartment.** When you need extra space, the individual sections of the 60:40 split rear seats can be folded to create an almost completely flat loading area measuring 1.57 metres with a luggage capacity of 1,547 litres. If you're using the B-Class as a 5-seater, you'll enjoy 488 litres of luggage space. For added flexibility, the height-adjustable load compartment floor is available as an option. Additionally, the B-Class features bag hooks, four load-securing rings and a load compartment cover to keep your cargo safe from prying eyes.



Set in the upper position, the optional height-adjustable load compartment reveals a handy storage area

**Easy-Vario-Plus Package** (optional). Adapting the B-Class to your requirements couldn't be simpler. Easy-Vario-Plus includes rear seats with fore/aft and tilt-angle adjustment and a folding rear armrest with twin cup holders.

**Load Compartment Package** (optional, standard with Easy-Vario-Plus Package). It includes a height-adjustable load compartment floor and folding storage. As an additional option, the package is also available with an integral safety net, which can be extended between either the B- or C-pillars depending on the cargo volume, helping to guard against injury from objects in the load compartment.





With the rear seats folded flat, the B-Class offers an almost entirely flat loading area with 1,547 litres of luggage space



## Seats and Memory Package

A totally new modular seating system was developed for the B-Class, equally satisfying the requirements of ergonomics, comfort and safety.

**Seats.** Front and rear passengers enjoy exceptionally comfortable seats and generous levels of leg and shoulder room. The driver also benefits from partial seat height adjustment. The stylish standard 'Domburg' fabric upholstery is available in grey or black. The Sport model features Artico artificial leather upholstery in a choice of stylish colours to suit your individual taste.

**Seat Comfort Package** (standard). To provide further comfort and individual ergonomic settings, especially for longer journeys, the driver and front passenger seats come with height and seat angle adjustment.

**4-way lumbar support for driver and front passenger** (optional). For the best support and comfortable seating positions, the backrest of both driver and front passenger seat can be individually adjusted. Both seats feature air chambers that can be set to your individual requirements for added lumbar support. Additionally, the air chamber height can also be modified.



The B-Class front seats offer a wealth of options for the most ergonomic and comfortable seating position

**Memory Package** (optional). With the optional Memory Package, the B-Class driver's and front passenger's seats feature full electric adjustment. The package also includes a memory function that can store up to three sets of positions for the driver's seat, head restraint and exterior mirrors. All settings can be retrieved at the touch of a button. When reversing, the exterior mirror on the passenger side is automatically lowered as well.



The Memory Package with full electric adjustment stores up to three individual seating positions



## Light and Sight

Light and Sight features multiple benefits: it enhances the ambiance of the beautiful interior and makes driving the B-Class a truly comfortable and reassuring experience.

**Light and Sight.** These features improve driving conditions and your safety considerably, especially when driving at night or in bad weather. It helps you to see and be seen more clearly. The Light and Sight features include rain-sensing windscreen wipers complete with larger screen-wash container, as well as warning lights on front doors and tailgate. Inside, the illuminated instrument panel, door trim and door handles all form part of the integrated ambient interior lighting, adding to the exclusive, welcoming feel of the B-Class. Whilst the sun visors with vanity mirror,

the rear-view mirror and the front footwells also feature elegant lighting, passengers in the rear can enjoy an ambient uplight and separately controllable left and right reading lights. Illuminated door sill panels for driver and front-seat passenger doors can be supplied as an addition to Light and Sight.



At night-time, the ambient interior lighting creates a stylish atmosphere on-board the B-Class



The tailgate features a handy warning light illuminating the area around the car



Both front footwells and doors are illuminated for your comfort and safety



## B-Class SE

The B-Class SE offers the kind of premium equipment you'd expect from a Mercedes-Benz, combined with plenty of space and versatility. The Light and Sight features and Active Park Assist come as standard, along with an Audio 20 radio/single CD system that includes Bluetooth® interface and USB port, an intuitive controller and a tablet-style central display. It also features innovative electronic assistants such as Collision Prevention Assist and Attention Assist.

---

### Exterior

---

16" alloy wheels

---

Heated exterior mirrors in body colour, electrically adjustable, and integral indicator

---

Light Assist with automatic light activation

---

Round LED daytime running lights

---

### Interior

---

Active Park Assist

---

Air conditioning

---

Attention Assist

---

Audio 20 radio/single CD with 5.8-inch screen and USB port

---

Collision Prevention Assist

---

Driver's kneebag

---

Electric parking brake

---

Matrix-look trim in Black

---

Multi-functional leather-trimmed steering wheel

---

Seat Comfort Package

---



Image shows optional Becker® Map Pilot navigation system

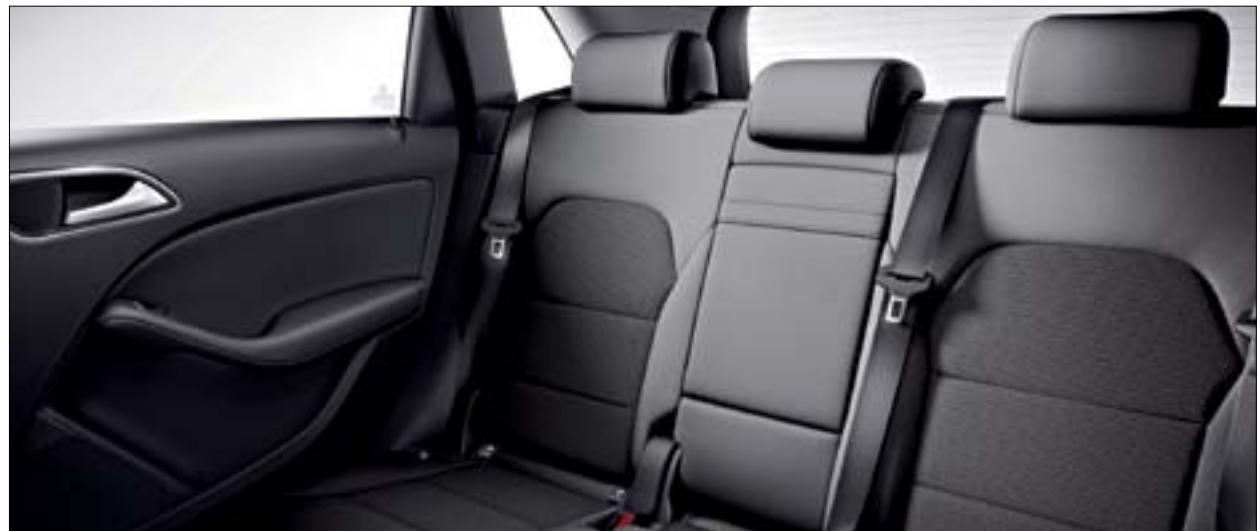

Image shows optional rear centre armrest







The image shows the B-Class SE featuring sleek 16" 10-spoke alloy wheels and optional front fog lamps





Image shows optional Becker® Map Pilot navigation system

Inside the B-Class SE, silver chrome details perfectly set off the tone-on-tone Black interior. Domburg fabric upholstery comes as standard as does the Matrix-look trim in Black. The Domburg cloth upholstery is available in either Black or Grey. Artico artificial leather in either Black, Sahara Beige or Crystal Grey is available as an option.

---

#### Domburg cloth

---

011 Black

018 Grey

---

#### Artico artificial leather

---

101 Black<sup>1</sup>

105 Sahara Beige<sup>1</sup>

108 Crystal Grey<sup>1</sup>

---

#### Trim

---

H88 Matrix Black

---

<sup>1</sup> Optional



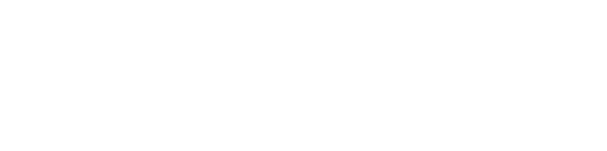
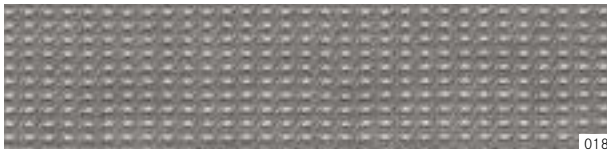

## B-Class Sport

The B-Class is proud of its sporty credentials. It comes with two-louvre sport grille, 18" bi-colour alloy wheels and heat-insulating dark-tinted glass. And for a truly dynamic drive, the Sport model is equipped with lowered comfort suspension and Direct Steer system.



Image shows optional luxury automatic climate control and Becker® Map Pilot navigation system

### Exterior

18" bi-colour alloy wheels with run-flat capable tyres

Bi-xenon with LED bar daytime running lights

Direct Steer system

Lowered comfort suspension

Reversing camera

Two-louvre grille

Visible twin exhausts

### Interior

Artico artificial leather upholstery

Privacy glass

Sports pedals with rubber studs



Image shows optional rear centre armrest





The B-Class Sport is fitted with lowered comfort suspension, 18" bi-colour alloy wheels, drilled front brake discs and optional panoramic sliding sunroof





Image shows optional panoramic sliding sunroof, luxury automatic climate control and Becker® Map Pilot navigation system

Inside, the sporty theme continues: the B-Class Sport features brushed stainless steel sports pedals with rubber studs, plus Artico artificial leather upholstery, Silver Honeycomb trim and a black roof lining.

---

**Artico artificial leather**

---

101 Black

105 Sahara Beige

108 Crystal Grey

---

**Trim**

---

H89 Silver Honeycomb

---



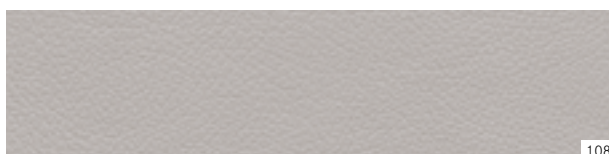
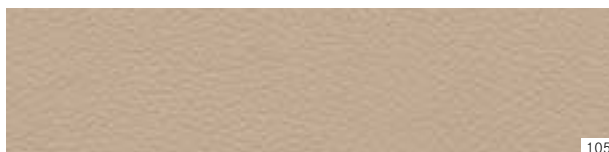
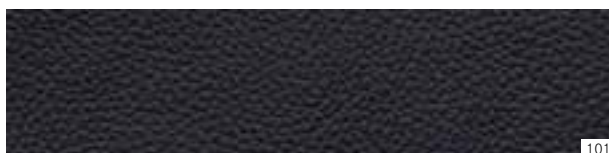

## Exclusive Package

The optional Exclusive Package is designed for all those who demand a little more luxury. It includes seats with real leather upholstery and 4-way lumbar adjustment in the front. There's a choice of three carefully appointed leather options: Lava Black, Hazelnut Brown and Crystal Grey. These colours are repeated throughout on door panels, armrests, and, if you opt for Crystal Grey, also beneath the dashboard and centre console.

### Interior

Adjustable centre console armrest with Artico artificial leather and top-stitching

Armrest on door panels with Artico artificial leather and top-stitching

Black Ash wood trim

Black roof lining (Hazelnut Brown upholstery)

Door panels in Artico artificial leather with top-stitching

Electronic locking system with infrared remote control

Floor mats with inset appointed interior colour

Front seats with 4-way lumbar adjustment

Grey roof lining (Lava Black, Crystal Grey upholstery)

Heated front seats

Leather-trimmed gear shift/selector lever with silver chrome ring

Leather upholstery with top-stitching

Stainless steel door sills

Storage – covered in black synthetic material

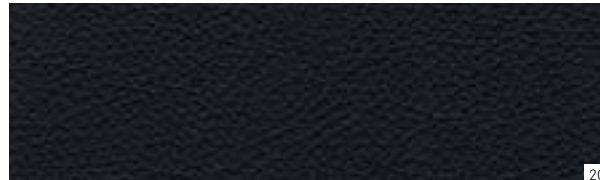

201

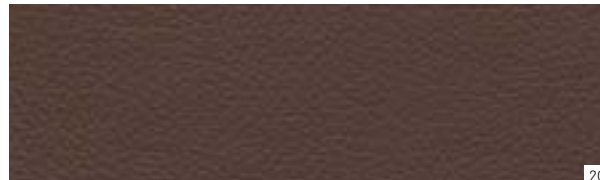

204

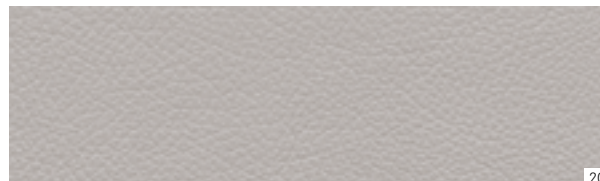

208



736



H03

Chrome elements on dashboard dials and controls as well as on the gear shift lever are perfectly balanced with the chosen interior colour, and set against Lava Black for the remainder of the interior with floor mats in the appointed interior colour. The dashboard is fitted with Black Ash or matt-finish Brown Burr Walnut wood interior trim.

### Leather

201 Lava Black

204 Hazelnut Brown

208 Crystal Grey

### Trim

736 High-gloss Black Ash wood

H03 Silk-matt Brown Burr Walnut wood (no-cost option)





Image shows optional COMAND Online system, luxury automatic climate control, 7G-DCT 7-speed dual-clutch automatic transmission, Harman Kardon® Logic 7® and Memory Package



# Standard equipment | Selection



Multi-function steering wheel



Audio 20 radio/single CD



Ambient lighting



Collision Prevention Assist



Air conditioning



Load compartment cover



## Optional extras | Selection



Panoramic sliding sunroof



Harman Kardon® Logic 7® surround sound system



Telephone pre-wiring



Becker® Map Pilot navigation system



Luxury automatic climate control



Memory Package



## Alloy wheels



Standard on B-Class SE: 16" 10-spoke alloy wheels, tyre size 205/55 R 16 (code 55R)



Standard on B-Class Sport: 18" bi-colour alloy wheels, tyre size 225/40 R 18 (code 01R)





Optional for B-Class SE: 17" 7-twin-spoke alloy wheels, tyre size 225/45 R17 (code 26R)



Optional for B-Class Sport at no extra cost: 17" 5-spoke alloy wheels, tyre size 225/45 R17 (code R24)



## Retailer-fit accessories

Concert hall, sports companion, holiday hold-all: adapting the B-Class exactly to your needs couldn't be simpler. → [www.mercedes-benz.co.uk/accessories](http://www.mercedes-benz.co.uk/accessories)



Great entertainment for the rear seats – with two high-resolution LCD colour displays

**Rear seat entertainment system.** This elegant DVD system enables passengers to view their favourite films and video games on the high-resolution 7-inch LCD colour display without disturbing the driver. One of the monitors is fitted with a DVD player, a USB port and an SD card slot to cater for various media. Whilst the second monitor serves as display only, both monitors can easily be removed, and if required, used externally via the 230/12-volt power supply.

The comprehensive equipment includes two infrared headphones and a remote control. As an option, the monitors are available separately. Your B-Class does not require any pre-wiring, allowing the rear seat entertainment system to be fitted at a later stage.



**Zig-zag load sill protection.** For scratch-free and comfortable loading, the B-Class can be fitted with a protective mat featuring highly durable nylon. When the load sill protection is not in use, it can be secured with velcro fittings and neatly tidied away on the luggage compartment floor behind the tailgate. For added comfort, the mat can be simply unfolded with one hand.



The load sill protection prevents scratches when loading and unloading

**The rear-mounted bicycle rack.** This lockable rear-mounted bicycle rack offers safe and comfortable transport for two or three bikes. Securing the bicycles is effortless, while the rack is easy to attach to the tow bar. A simple fold-down mechanism means that the boot can still be opened. When folded, the rack can be stored in a handy nylon bag.



The rear-mounted bicycle rack is available for two or three bikes

**Roof boxes.** These highly durable roof boxes have been aerodynamically designed to suit the B-Class. For easy loading and unloading, they can be opened from both sides. The boxes are available in two sizes: the Family box in metallic Black or matt Silver has a loading capacity of 450 litres, whilst the Sport Box in metallic Titan or matt Silver offers 330 litres.



The roof boxes are available in two colours, offering a loading capacity of 330 litres or 450 litres



## Services

**Test drive.** Words can only do so much. Some things have to be experienced to be truly appreciated. Which is why we'd like to invite you for a test drive. Feel the power of efficient engines that offer impressive fuel consumption. Feel exhilarated by precise steering, designed to connect the driver with the road and enjoy sumptuous levels of comfort. Your Mercedes-Benz Retailer will be happy to make arrangements for you to experience the things that set a Mercedes-Benz apart. Alternatively, to request a test drive online simply visit [www.mercedes-benz.co.uk/testdrive](http://www.mercedes-benz.co.uk/testdrive). We look forward to seeing you.

**Mercedes-Benz Finance.** At Mercedes-Benz Finance, our single-minded aim is to provide optimum financial solutions for all those who share the Mercedes-Benz philosophy of absolute commitment to quality. Whether you are a private customer or a business user, our finance and leasing packages can be tailored to meet your individual

needs. For further information on Mercedes-Benz Finance, please contact your local Mercedes-Benz Retailer.

**Mercedes-Benz Insurance** offers a fully comprehensive 5 star<sup>1</sup> Motor Insurance policy specifically designed to give you the cover you would expect from Mercedes-Benz. For a quotation, please call 0845 600 2180?



**Factory Collection.** The Factory Collection experience provides the opportunity to collect your brand new Mercedes-Benz from three different locations, depending on which model you have chosen. For more information, please contact your local Retailer, the Mercedes-Benz Factory Collection team on 0845 273 9705 or visit [www.mercedes-benz.co.uk/factorycollection](http://www.mercedes-benz.co.uk/factorycollection)

**Interactive Owner's Manual.** The website also offers an interactive tour, enabling you to take a closer look at your desired model. This simulation is the ideal way to acquaint yourself with your dream car. You can view key functions in detail, gain an insight into the car's inner workings or look at the benefits of each model. For further details, visit [www.mercedes-benz.co.uk/bclassmanual](http://www.mercedes-benz.co.uk/bclassmanual)





**Roadside Assistance.** Rest assured that should you ever need help, Mercedes-Benz Roadside Assistance is there for you. In the unlikely event of a technical breakdown<sup>3</sup> you can rely on the Mercedes-Benz Roadside Assistance Team – anywhere in Europe. Simply phone our Customer Assistance Centre on 00800 1 777 7777,<sup>4</sup> where our specialists will organise assistance for you. Mercedes-Benz will also assist you in the event of a minor mishap preventing you from driving your vehicle<sup>3</sup>. Whether you lose your key, run out of fuel or your vehicle is damaged due to an accident or vandalism, Mercedes-Benz ensures that you still reach your destination. Often the problem can be rectified on the spot, but if this is not possible, we will naturally ensure that your vehicle is taken to the nearest Mercedes-Benz Official Workshop to get you back on the road as quickly as possible.

<sup>1</sup> As rated by Defaqto, a leading UK independent financial research company.  
Mercedes-Benz Motor Insurance is underwritten by Aviva Insurance Limited  
<sup>2</sup> Calls are charged at local rate and may be recorded

**Mercedes-Benz World at Brooklands.** Celebrate the story of Mercedes-Benz and you'll celebrate the story of motoring itself at Mercedes-Benz World in Surrey. A World of experiences. Discover Mercedes-Benz racing heritage, from its connections to the famous Brooklands circuit through to present-day Formula 1™ brought to life in the most sensational way. View, touch and sit in every car from the Mercedes-Benz range, and encounter automotive legends like the 'Gullwing' and many other classic icons, in the UK's largest Mercedes-Benz showcase. Then set your pulse racing by booking one of our thrilling Driving Experiences. Enjoy AMG performance on the purpose-built Handling Circuits or Wet Skid Circle, an axle-twisting off-road adventure, or treat your kids over 1.5 metres tall to their own driving experience in an A-Class or on the off-road terrain in an M-Class.

<sup>3</sup> Cover is initially valid for your vehicle for four years from the date of first registration. This can be extended from the fifth year, up to a maximum of 30 years, on completion of each scheduled maintenance service, providing that this service is carried out by a Mercedes-Benz

And for kids even younger and under 1.3 metres tall, let them be a 'Little Learner' in their own miniature electric version of the desirable Mercedes-Benz SL. For more interactive action, take a virtual 3D journey along the production line in 'Build' and take a seat in the cinema to accelerate from the birth of the car to the latest innovations in 20 eye-opening minutes.

Relax and refuel in Café 1886, or for something more enjoy the delicious menu and elegant surroundings of the Gullwing Restaurant. Finally, extend your visit with a short stroll to Brooklands Museum to see their collection of classic cars, aviation exhibitions – and the legendary Concorde. For more information visit [www.mercedes-benzworld.co.uk](http://www.mercedes-benzworld.co.uk)

Official Workshop. Minor mishap cover is provided at the absolute discretion of Mercedes-Benz  
<sup>4</sup>In non-affiliated European countries: +44 20 7975 7077



# Dimensions

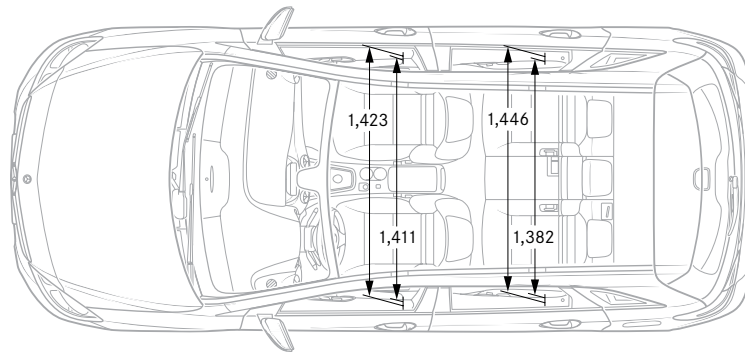
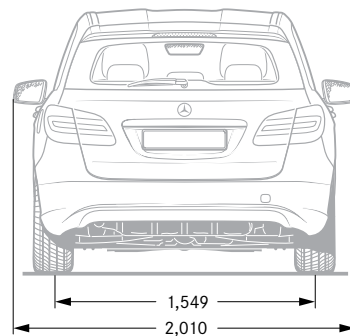
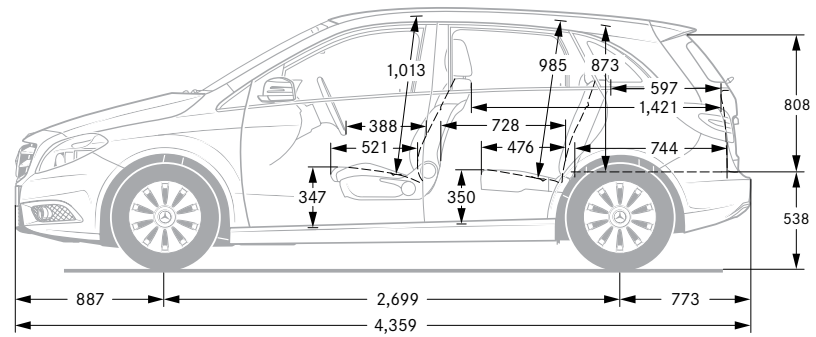
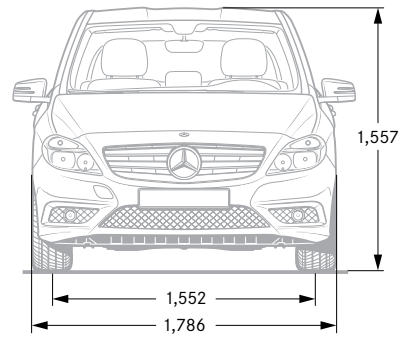

All measurements in millimetres. The dimensions shown are mean values and apply to standard-specification, unladen vehicles



# Technical data

No. of cylinders/arrangement
Total displacement – cc
Rated output <sup>1</sup> – hp (kW) at rpm
Rated torque <sup>1</sup> – Nm at rpm
Acceleration 0–62 mph – sec (auto.)
Top speed, approx. – mph (auto.)
Tyre size
Fuel consumption <sup>2</sup> – mpg (auto.)
Urban
Extra-urban
Combined
EU emissions standard
CO <sub>2</sub> emissions, combined <sup>2</sup> – g/km (auto.)
Fuel tank capacity/reserve (approx.) – l
Boot capacity – l
Turning circle – m
Kerb weight <sup>3</sup> – kg
Perm. GVW – kg
Permissible towing capacity – kg
unbraked/braked

## Diesel engines

### B 180 CDI BlueEFFICIENCY

4/in-line
1,796
107 (80)/3,200-4,600
250/1,400–2,800
10.9 (10.7)
118 (118)
205/55 R16

### B 200 CDI BlueEFFICIENCY

4/in-line
1,796
134 (100)/3,600-4,400
300/1,600–3,000
9.5 (9.3)
130 (130)
205/55 R16

52.3 (56.5)
74.3 (70.6)
64.2 (67.3)

52.3 (56.5)
74.3 (70.6)
64.2 (67.3)

### Euro 5

### Euro 5

115-121 (116-122)
-------------------

115-121 (116-122)
-------------------

50/6.01
---------

50/6.01
---------

488-1,547
-----------

488-1,547
-----------

11.00
-------

11.00
-------

1,475 (1,505)
---------------

1,475 (1,505)
---------------

2,030 (2,025)
---------------

2,030 (2,025)
---------------

735/1,200 (750/1,200)
-----------------------

735/1,400 (750/1,400)
-----------------------

<sup>1</sup> Figures according to Directive 80/1269/EEC in the currently applicable version <sup>2</sup> The figures shown were obtained in accordance with the prescribed measuring process (Directive 80/1268/EEC in the currently applicable version). The figures are not based on an individual model and do not constitute part of the product offer; they are provided solely for purposes of comparison between different vehicle models

<sup>3</sup> Figures according to Directive 92/21/EC, version 95/48/EC (kerb weight with fuel tank 90% full, driver, 68 kg, and luggage, 7 kg) for standard-specification vehicles. Optional extras and accessories will generally increase this figure and reduce the payload capacity accordingly



No. of cylinders/arrangement
Total displacement – cc
Rated output <sup>1</sup> – hp (kW) at rpm
Rated torque <sup>1</sup> – Nm at rpm
Acceleration 0–62 mph – sec (auto.)
Top speed, approx. – mph (auto.)
Tyre size
Fuel consumption <sup>2</sup> – mpg (auto.)
Urban
Extra-urban
Combined
EU emissions standard
CO <sub>2</sub> emissions, combined <sup>2</sup> – g/km (auto.)
Fuel tank capacity/reserve (approx.) – l
Boot capacity – l
Turning circle – m
Kerb weight <sup>3</sup> – kg
Perm. GVW – kg
Permissible towing capacity – kg
braked/unbraked

## Petrol engines

## B 180 BlueEFFICIENCY

## B 200 BlueEFFICIENCY

4/in-line	4/in-line
1,595	1,595
121 (90)/5,000	154 (115)/5,300
200/1,250-4,000	250/1,250-4,000
10.4 (10.2)	8.6 (8.4)
118 (118)	137 (137)
205/55 R16	225/40 R18
35.3 (37.2)	34.5 (37.2)
60.1 (58.9)	57.7 (57.7)
47.9 (48.7)	46.3 (47.9)
Euro 5	Euro 5
138-144 (138-145)	144 (145)
50/6.01	50/6.01
488-1,547	488-1,547
11.00	11.00
1,395 (1,425)	1,395 (1,425)
1,960 (1,950)	1,960 (1,950)
695/1,200 (710/1,200)	695/1,400 (710/1,400)

<sup>1</sup> Figures according to Directive 80/1269/EEC in the currently applicable version <sup>2</sup> The figures shown were obtained in accordance with the prescribed measuring process (Directive 80/1268/EEC in the currently applicable version). The figures are not based on an individual model and do not constitute part of the product offer; they are provided solely for purposes of comparison between different vehicle models

<sup>3</sup> Figures according to Directive 92/21/EC, version 95/48/EC (kerb weight with fuel tank 90% full, driver, 68 kg, and luggage, 7 kg) for standard-specification vehicles. Optional extras and accessories will generally increase this figure and reduce the payload capacity accordingly

## Paint finishes

The innovative Mercedes-Benz paint system features one of the finest clearcoats of any manufacturer. Its exceptionally dense molecular structure makes the paintwork more durable and lends it a deeper, more lasting sheen, helping your B-Class to retain both its looks and its long-term value.

### Non-metallic paints



589

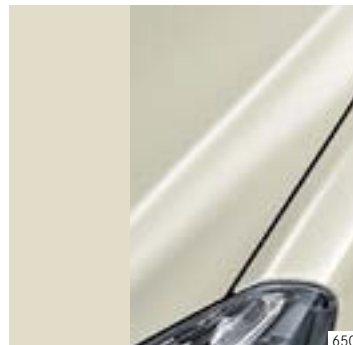

650

### Non-metallic paints (standard)

- 589 Jupiter Red
- 650 Cirrus White

### Metallic paints (optional)

- 191 Cosmos Black
- 240 Lotus Blue
- 761 Polar Silver
- 787 Mountain Grey
- 893 Monolith Grey
- 894 Universe Blue
- 895 Canyon Beige

### Metallic paints



191

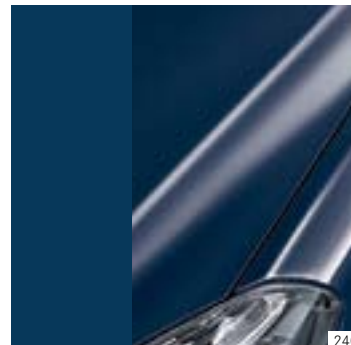

240



761



787

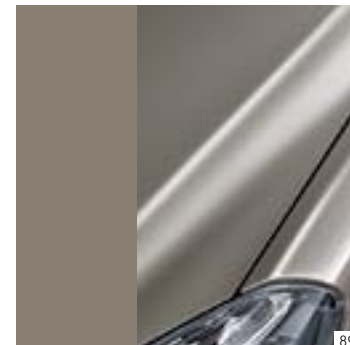

893

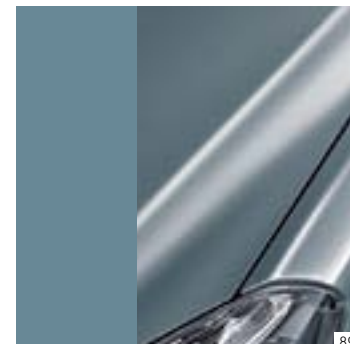

894



895



**Take-back of end-of-life vehicles. Coming full circle.** At the end of its long life, you can return your B-Class to us for environment-friendly disposal in accordance with the EC End-of-Life Vehicle Directive!<sup>1</sup> But that day lies a long way off.

<sup>1</sup>Applies in accordance with national regulations to vehicles up to 3.5t permissible gross weight. The B-Class has met the statutory regulations governing the suitability of the vehicles' design for reuse and recycling for a number of years now. A network of vehicle take-back depots and dismantlers has been established which will process your vehicle in an environment-friendly manner. The ways in which both vehicles and parts can be recovered are subject to ongoing development and improvement. Consequently, the B-Class will be able to comply with any future increases in the recycling quota within the stipulated time limits. For further information, please go to [www.mercedes-benz.co.uk](http://www.mercedes-benz.co.uk) or call 0808 156 6606.

Please note: this online version of the printed brochure may contain abridged copy or other content changes. The manufacturer reserves the right to make changes to the design, form, colour and specification during the delivery period, provided these changes, while taking into account the interests of the vendor, can be deemed reasonable with respect to the purchaser. Where the vendor or the manufacturer uses symbols or numbers to describe an order or the subject of an order, no rights may be derived solely from these. The illustrations may show accessories and items of optional equipment which are not part of standard specification. Colours may differ slightly from those shown in the brochure, owing to the limitations of the printing process. This brochure has been compiled by Daimler AG of Germany and is distributed internationally. It provides a general indication of the range of models, features, optional extras and/or colours available in various countries. Some of the models, features, optional extras and/or colours shown may not be available in your country or may only be available in a different specification. Additionally some models, features, optional extras and/or colours may only be available in combination with others. For current and more specific information in relation to the range of models, features, optional extras and/or colours available in your country, and their pricing, you should contact your nearest authorised Mercedes-Benz Retailer. E&OE. [www.mercedes-benz.co.uk](http://www.mercedes-benz.co.uk)

